

- | | |
|----------------------------------|------------------------------|
| (D) Montageanleitung | (FR) Notice de montage |
| (NL) Handleiding voor de montage | (CZ) Montážní návod |
| (HU) Szerelési útmutató | (TR) Montaj talimatı |
| (GB) Assembly instructions | (IT) Istruzioni di montaggio |
| (PL) Instrukcja montażu | (SK) Návod na montáž |
| (RO) Instrucțiuni de montaj | (RU) Инструкция по монтажу |

**Service • Assistenza • Dienstverlening • Serwis
Servis • Szerviz • Сервисная служба**

Name • Nom • Nome • Naam •
Nazwa • Jméno • Názov • Név •
Denumire • Ísim • Название

Nr. • No. • N° • Номер • Č • Sz

Тур • Type • Tip • Típus • Tipo •
Тип

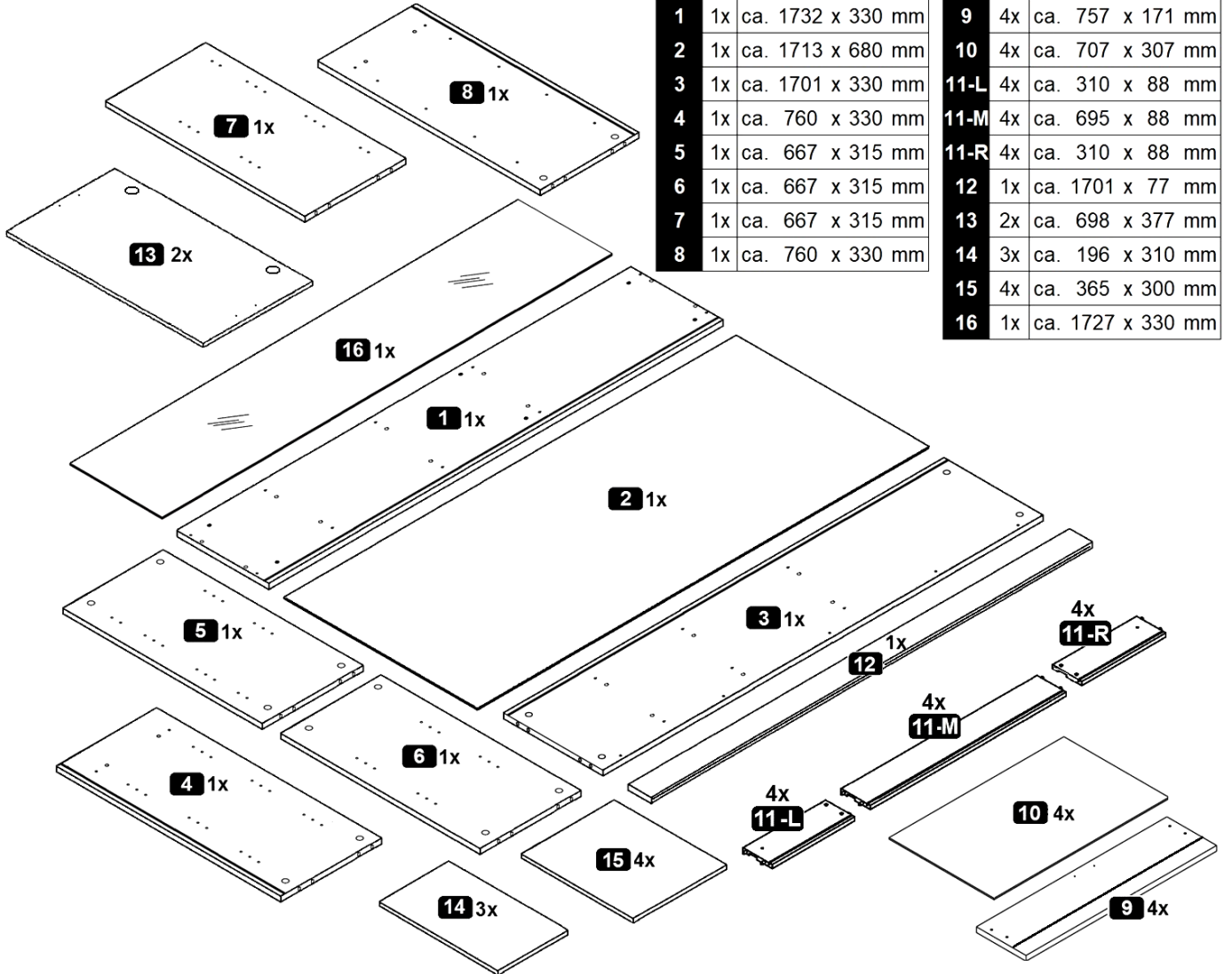
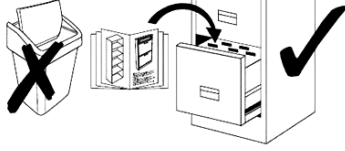
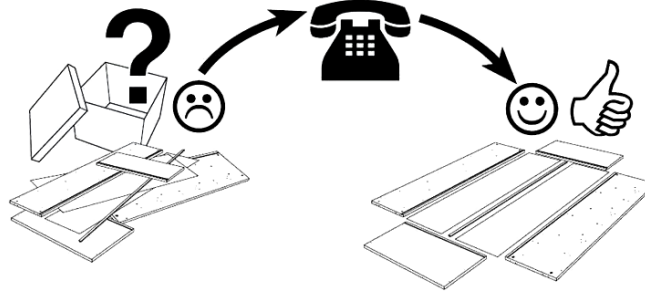

1	1x	ca. 1732 x 330 mm	9	4x	ca. 757 x 171 mm
2	1x	ca. 1713 x 680 mm	10	4x	ca. 707 x 307 mm
3	1x	ca. 1701 x 330 mm	11-L	4x	ca. 310 x 88 mm
4	1x	ca. 760 x 330 mm	11-M	4x	ca. 695 x 88 mm
5	1x	ca. 667 x 315 mm	11-R	4x	ca. 310 x 88 mm
6	1x	ca. 667 x 315 mm	12	1x	ca. 1701 x 77 mm
7	1x	ca. 667 x 315 mm	13	2x	ca. 698 x 377 mm
8	1x	ca. 760 x 330 mm	14	3x	ca. 196 x 310 mm
			15	4x	ca. 365 x 300 mm
			16	1x	ca. 1727 x 330 mm

A	8,0 x 30 mm	B	20x	C	20x	D	6x	E	4,0 x 13 mm	F	1x	G	3,0 x 40 mm	5x
H	8x	I	6,3 x 13 mm	J	M4 x 9 mm	K	28x	L	h=2	M	gerade	N	Kr.15	2x
O	2,7 x 20 mm	P	6,3 x 50 mm	Q	6x	R	6x	S	h=4	T	Gummipuffer		10x	





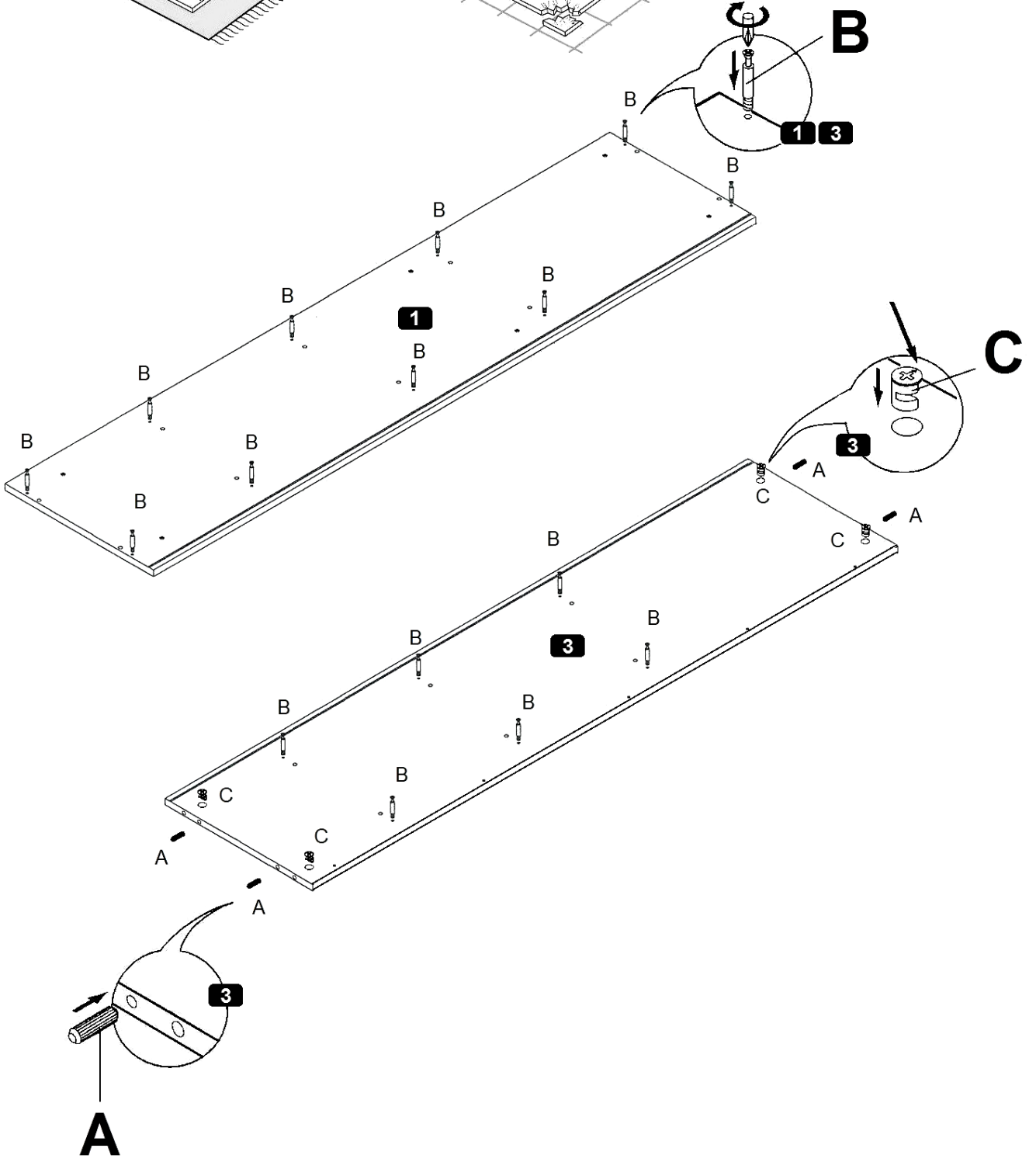
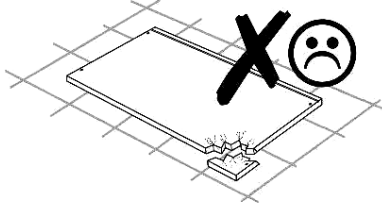
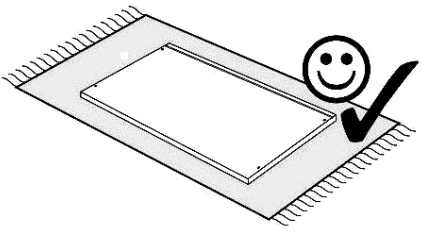
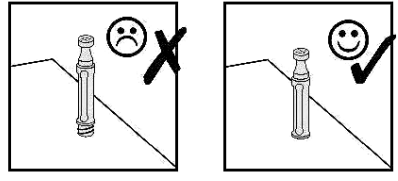

1

- A** 8,0 x 30 mm **4x**
- B** **16x**
- C** **4x**





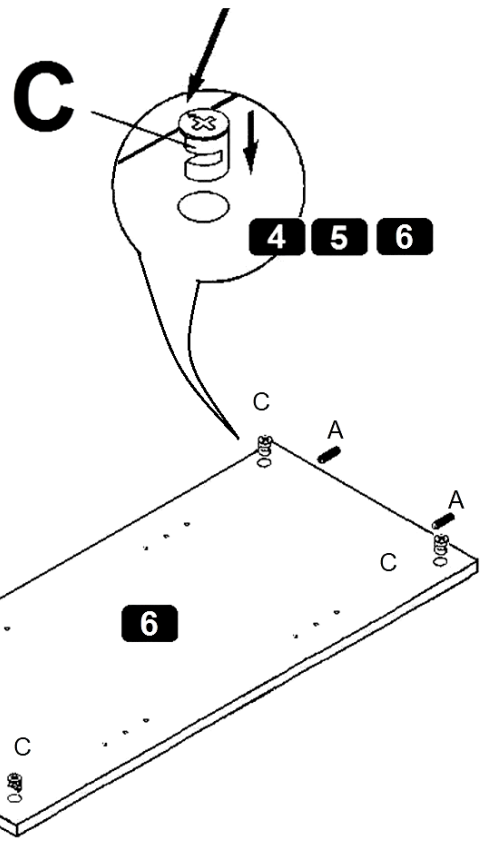
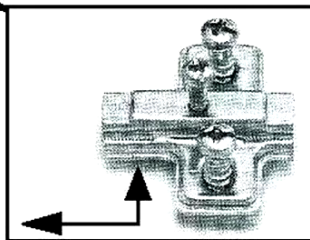
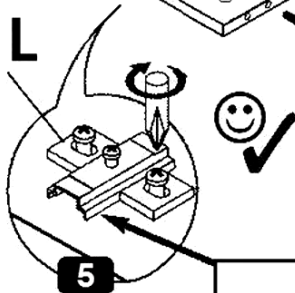
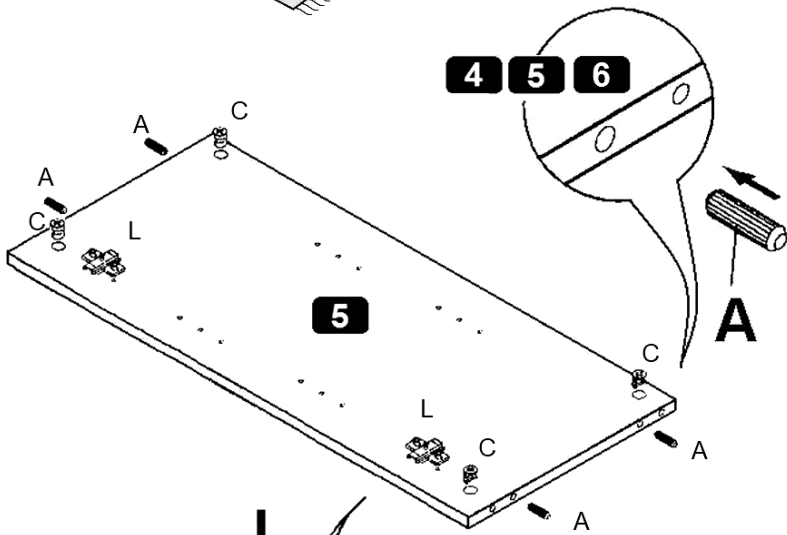
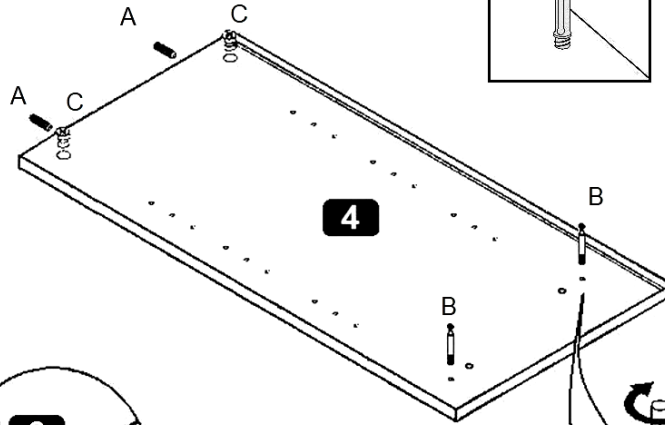
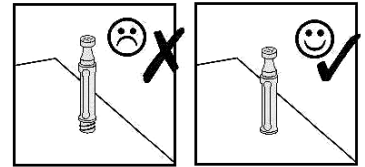
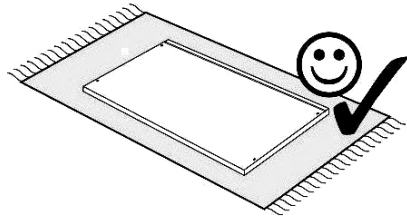
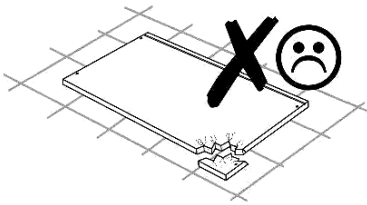

2

A 8,0 x 30 mm  10x	B  2x	C  10x	L  h=2 2x
---	--	---	---

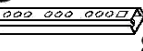

3

A 8,0 x 30 mm  6x	B  2x	C  6x	H  8x	I 6,3 x 13 mm  16x	S  h=4 2x
--	--	--	--	---	---

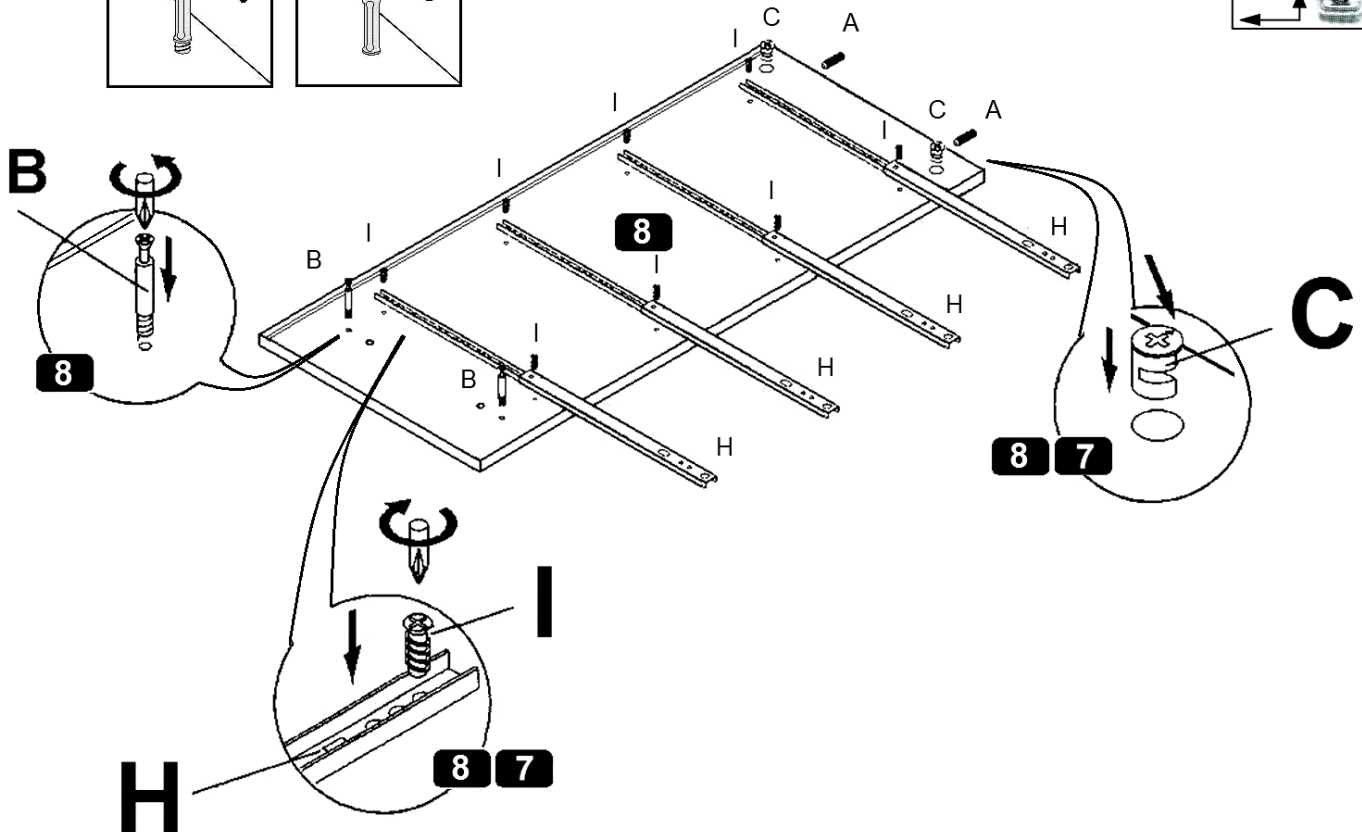
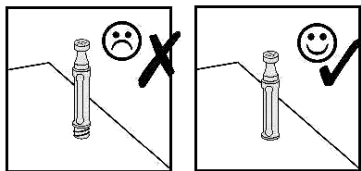
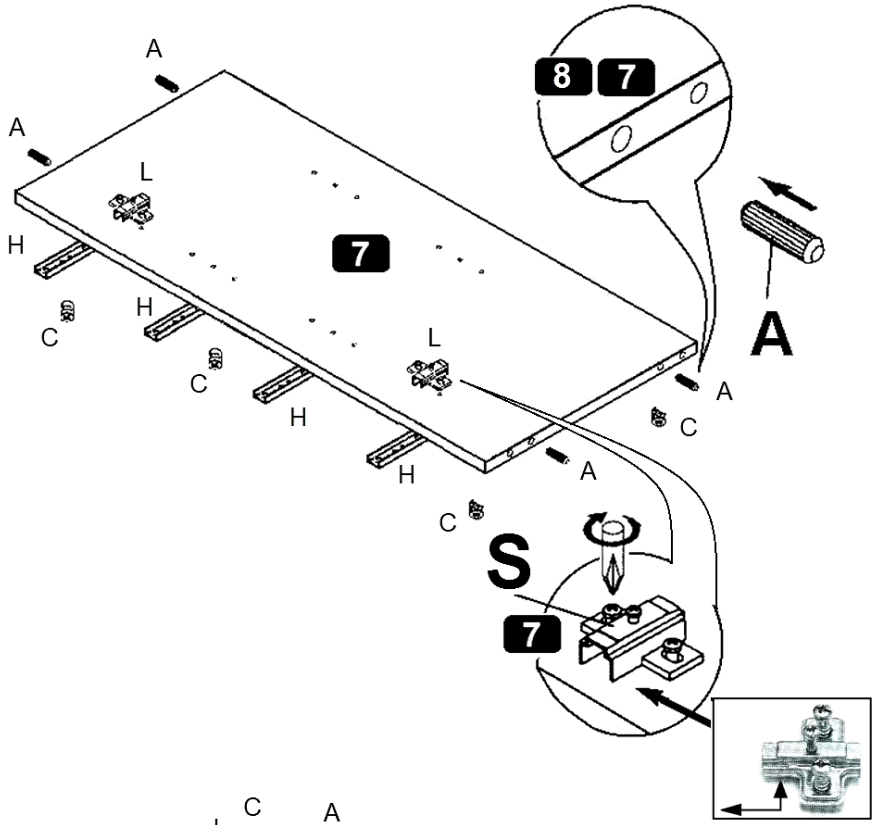
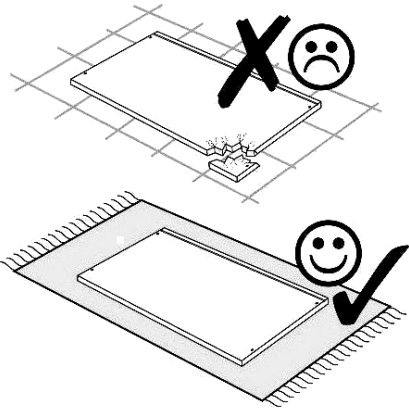

4 Gummipuffer 8x

D 4x
E 4,0 x 13 mm 8x

F 1x

D Leim
 GB Glue
 FR Colle
 IT Colla
 NL Lijm
 PL Klej
 CZ Lepidlo
 SK Glej
 HU Enyv
 RO Adeziv
 TR Tutkal
 RU Клей

2.

4x **1.** 11-R 11-M 11-L

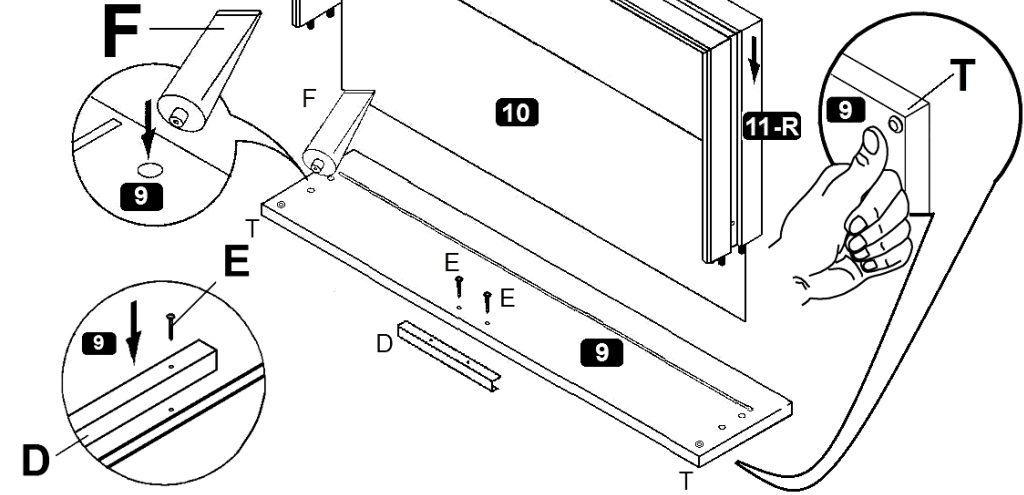
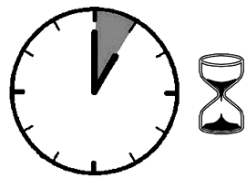

5

G 3,0 x 40 mm 5x
Q 6x
R 6x
P 6,3 x 50 mm 6x

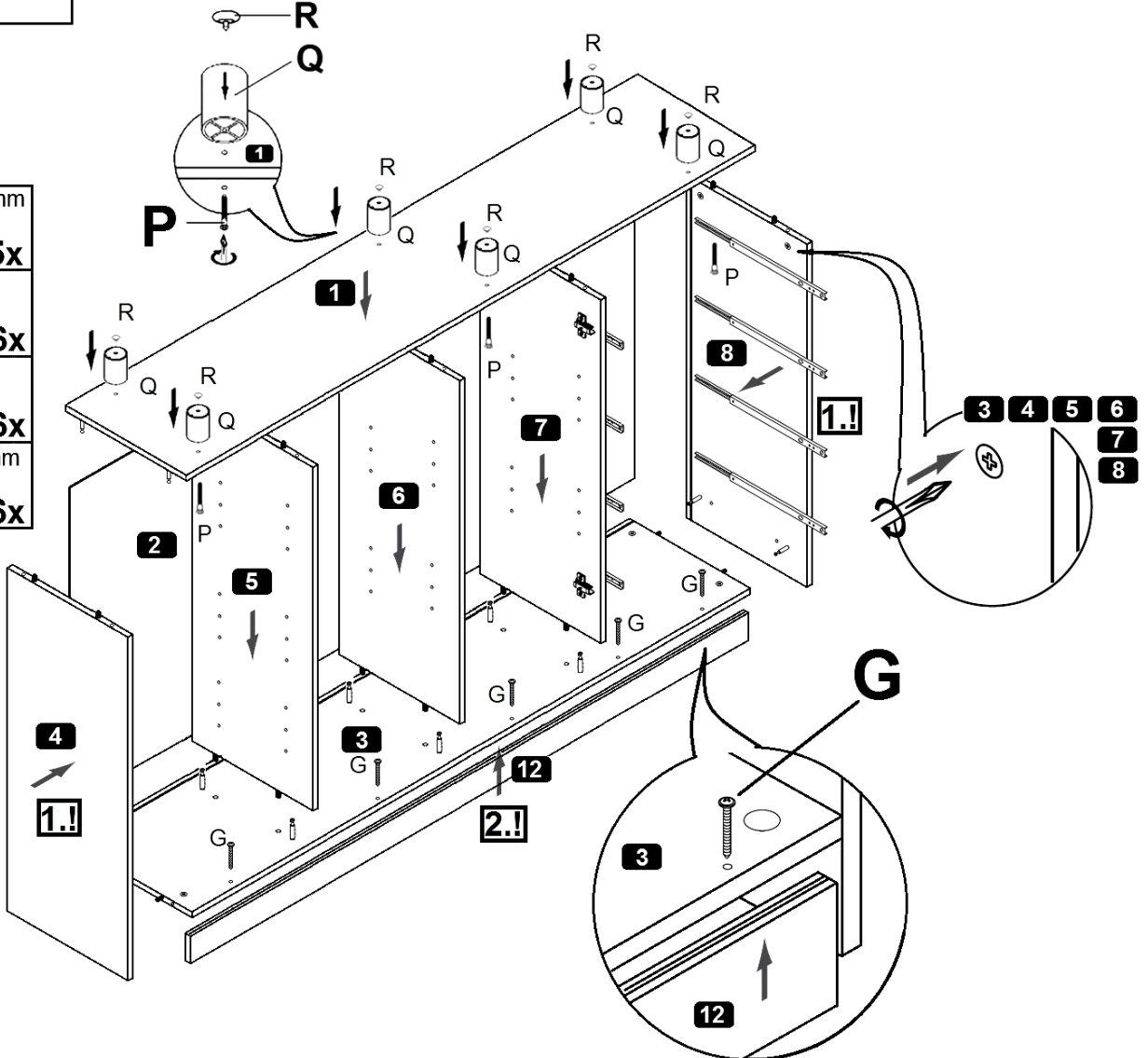

6

- J** M4 x 9 mm
8x
- K**
28x
- O** 2,7 x 20 mm
12x

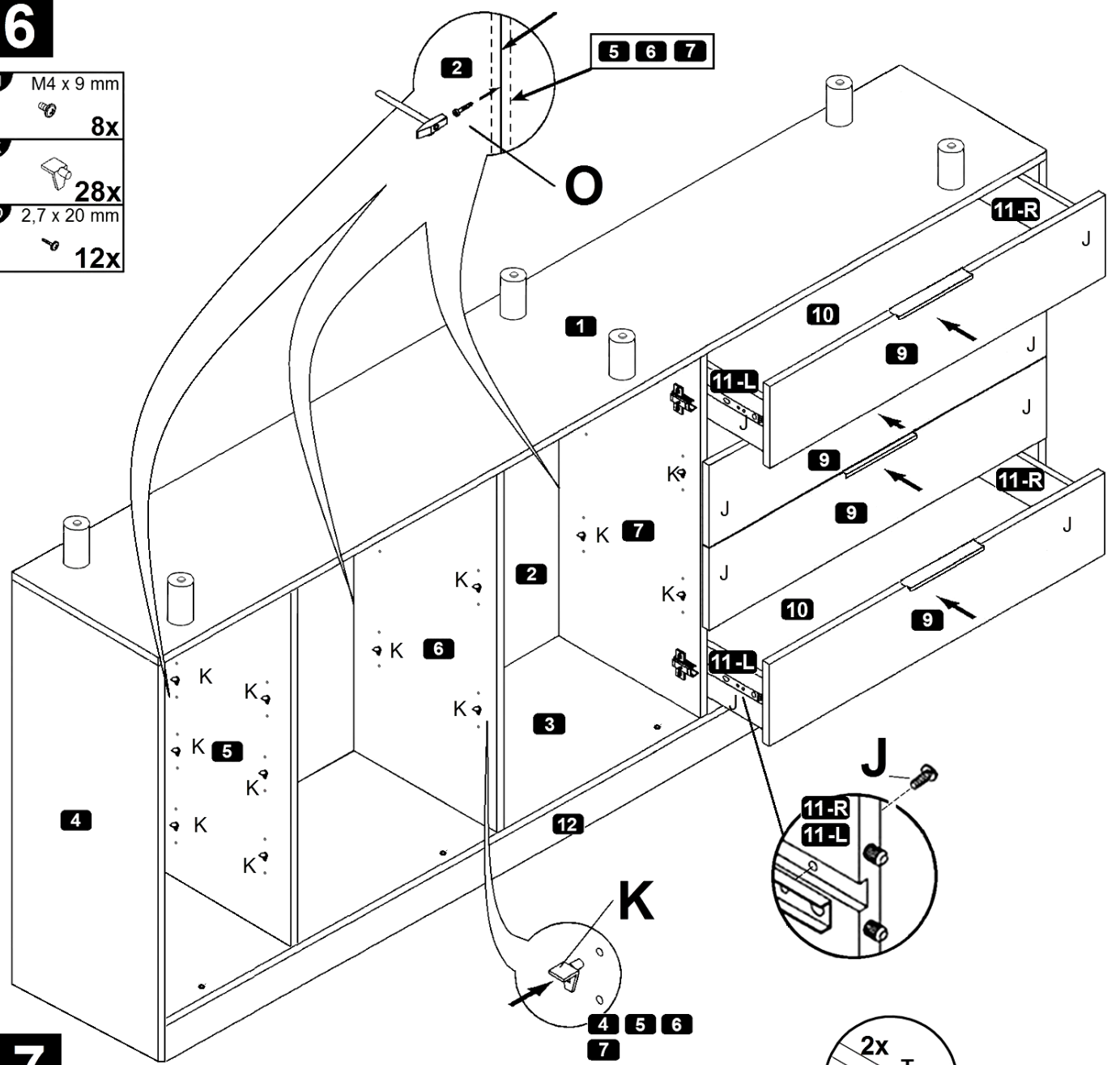

7

- D** 2x
- E** 4,0 x 13 mm
4x
- M** gerade
2x
- N** Kr. 15
2x
- T** Gummipuffer
2x

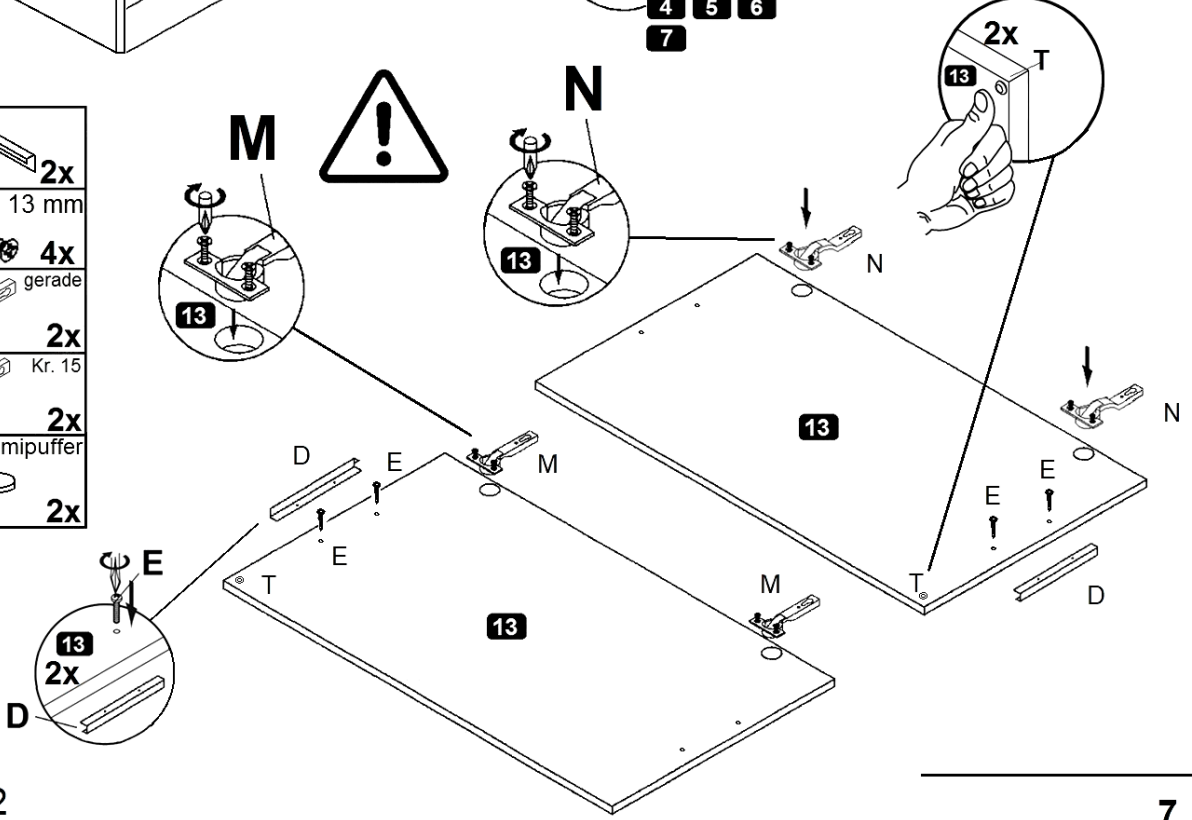

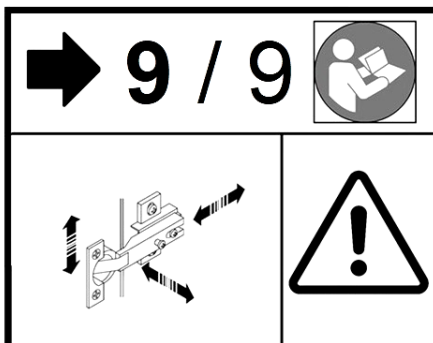
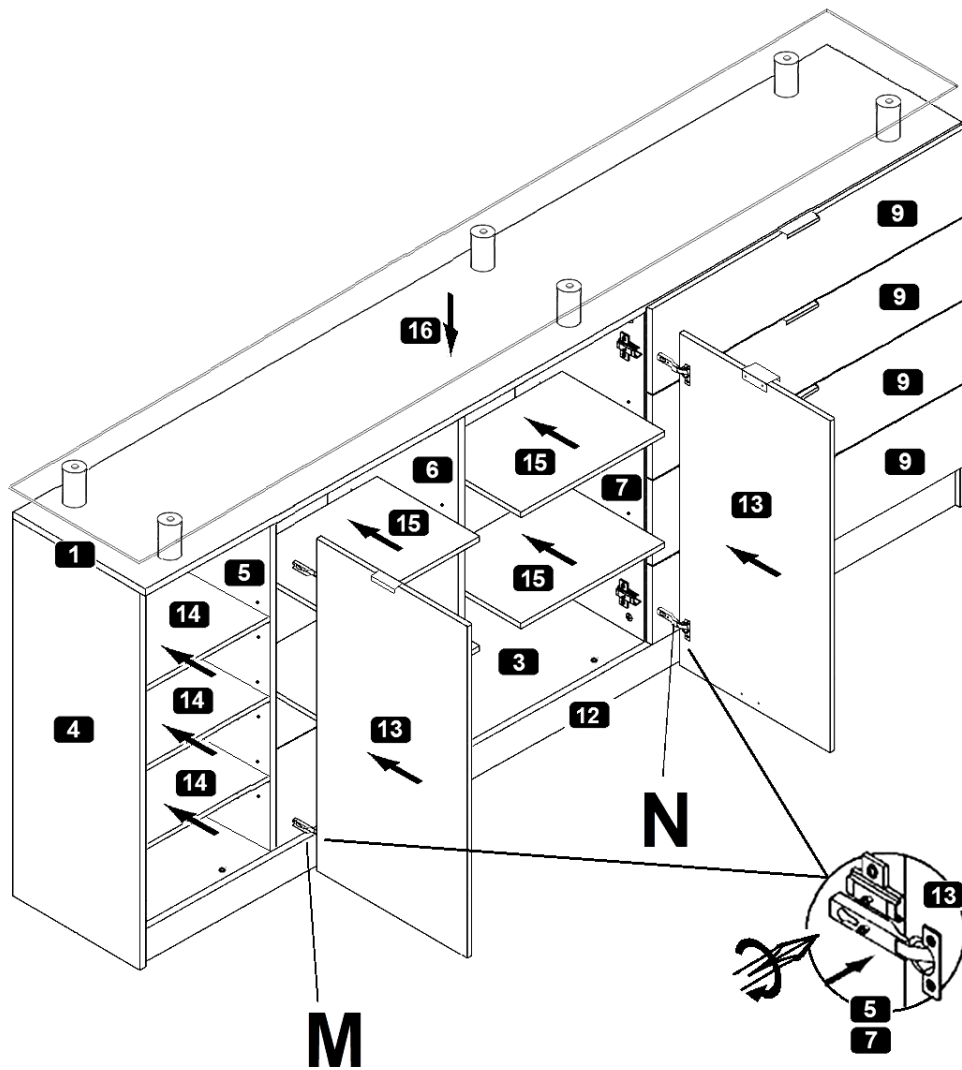

- (D) Türen einstellen
(Scharniere justieren)
- (GB) Adjusting the doors
(adjusting the hinges)
- (FR) Régler les portes
(ajuster les charnières)
- (IT) Sistemare le porte
(regolare le cerniere)
- (NL) Deuren instellen
(scharnieren afstellen)

- (PL) Nastawić drzwi
(wyregulować zawiasy)
- (CZ) Vyrovnajte dvířka
(seřid'te závěsy)
- (RO) Nastavenie dverí
(nastavenie závesov)
- (HU) Állítsa be az ajtókat
(állítsa be a zsanérokot)
- (SK) Reglare uši
(ajustare balamale)
- (TR) Kapıların ayarlanması
(menteselerin seviye ayarı)
- (RU) Регулировка дверей
(регулировка шарнира)

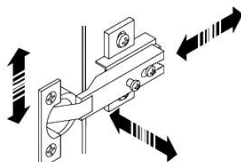

D Türen einstellen
(Scharniere justieren)

GB Adjusting the doors
(adjusting the hinges)

FR Régler les portes
(ajuster les charnières)

IT Sistemare le porte
(regolare le cerniere)

NL Deuren instellen
(scharnieren afstellen)

PL Nastawić drzwi
(wyregulować zawiasy)

CZ Vyrovnajte dvířka
(seřid'te závěsy)

RO Nastavenie dverí
(nastavenie závesov)

HU Állítsa be az ajtókat
(állítsa be a zsanérokot)

SK Reglare uši
(ajustare balamale)

TR Kapıların ayarlanması
(menteşelerin seviye ayarı)

RU Регулировка дверей
(регулировка шарнира)

