

80-20101-40

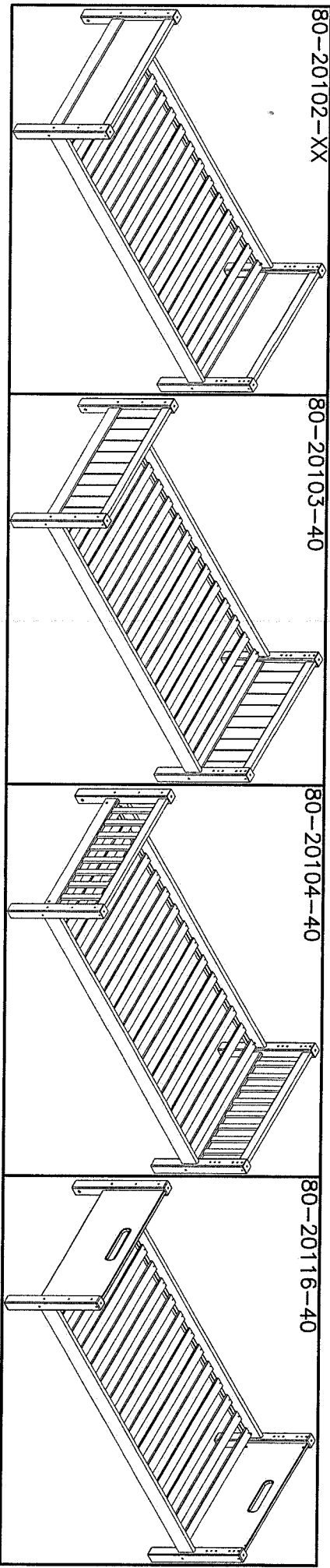

See assembly instruction in box no.
 Voir notice de montage dans la coisse no.
 Siehe Aufbauanleitung im Karton no.
 Zie voor de montage-instructie pakketnr.

Before assembling this product, please ensure that all the components supplied comply with the list on this page. All Screw-type fittings can be tightened with this tool.

Avant de commencer l'assemblage, veuillez contrôler si tous les objets indiqués sont présents. Tous les vis peuvent être serrés par cet outil.

Bevor Sie mit dem Aufbau beginnen, kontrollieren Sie ob alle auf der Zeichnung angegebenen Teile vorhanden sind. Bitte verwenden Sie zur Montage einen Kreuzschraubenzieher und den beiliegenden Innesschlüssel.

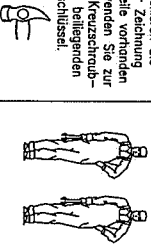
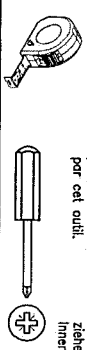

Ware-nr. Part no. Réf. No	Sik. Qty. Qté.
Siehe Bild-nr. See picture no. Image no	Mess Dim. Dim.

12-06306473-40 2 stick/pcs.	12-06306474-40 2 stick/pcs.	1305-19672-40 2 stick/pcs.
A		
647x63x63 3922-08018 8 stick/pcs.	647x63x63 3930-10050 16 stick/pcs.	647x63x63 3909-70100 30 stick/pcs.
B		
C		
1967x115x26 4 stick/pcs.	1967x115x26 4 stick/pcs.	1967x115x26 2 stick/pcs.

Z1 M6/ø12x18 mm. 3913-08110 8 stick/pcs.	Z2 ø10x50 mm. 3938-00010-2 20 stick/pcs.	Z3 ø7x100 mm. 3938-00016-2 4 stick/pcs.	Z4 ø4x30 mm. 4033-005 1 stick/pcs.
Z5 M8x110 mm. 1967x115x26 2 stick/pcs.	Z6 ø8 mm. 1967x115x26 2 stick/pcs.	Z7 ø10 mm. 1967x115x26 2 stick/pcs.	Z8 ø16 mm. 1967x115x26 2 stick/pcs.

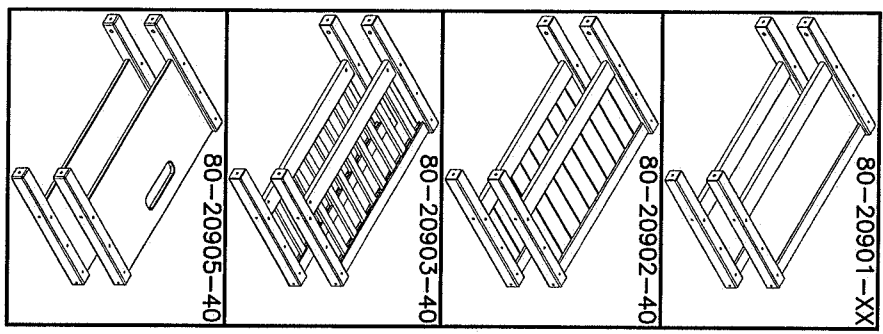

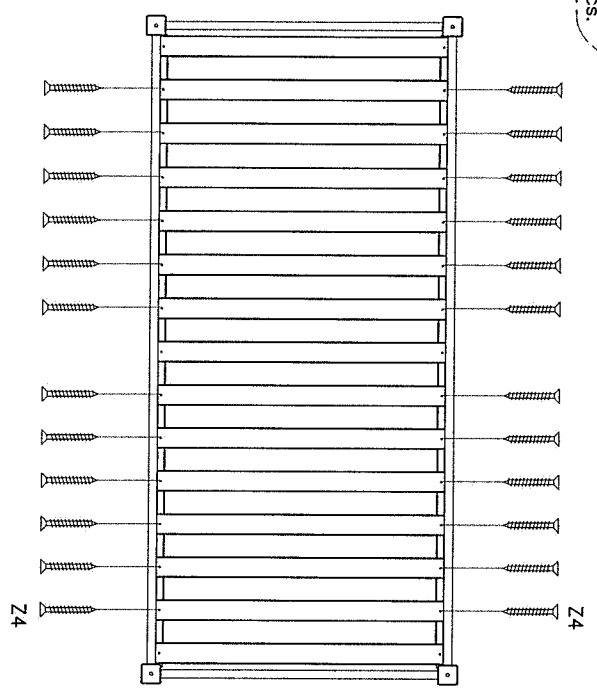
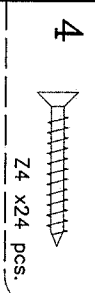
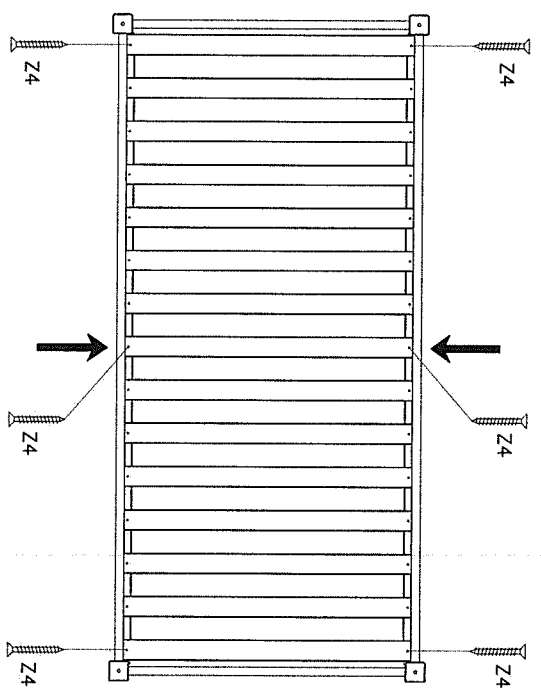
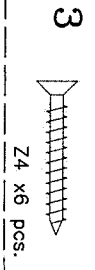
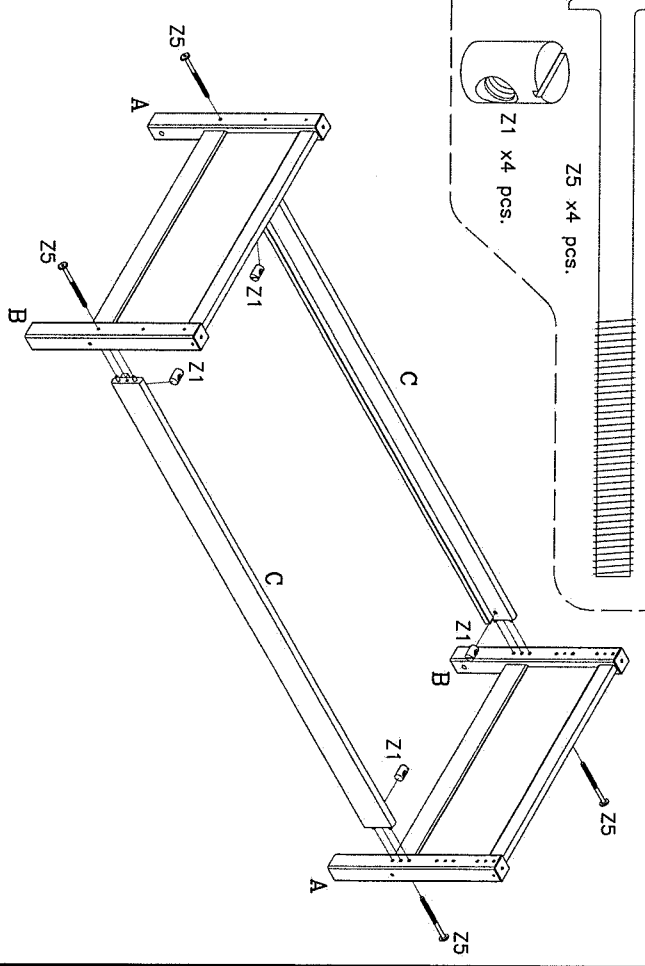
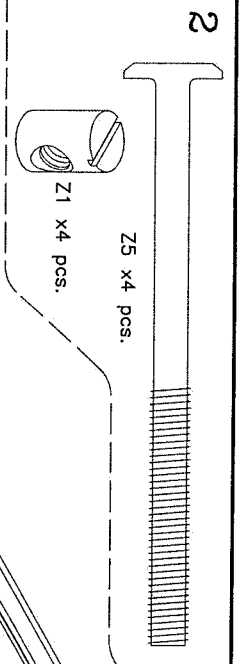
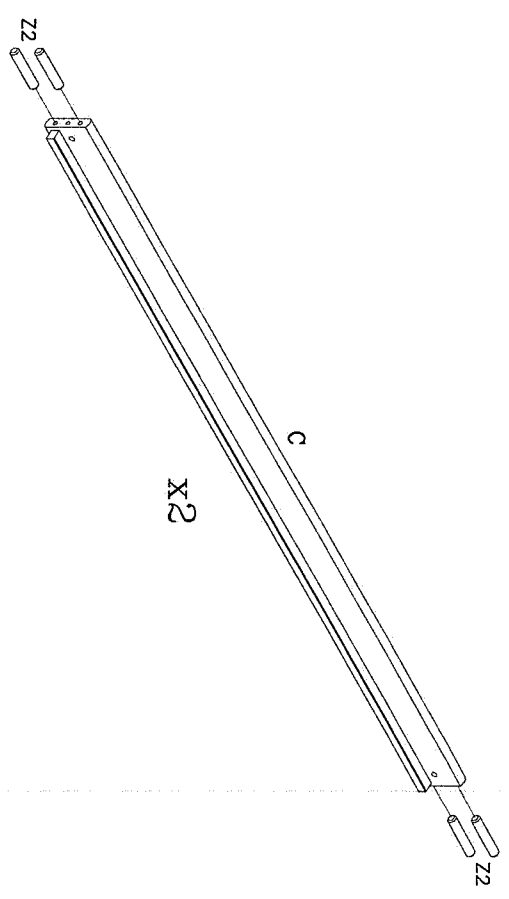

80-20905-40 White

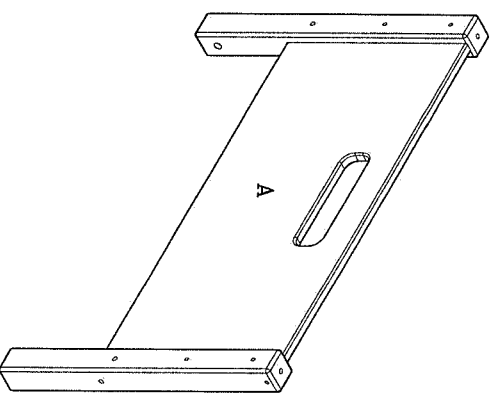

Before assembling this product, please ensure that all the components supplied comply with the list on this page. All Screw-type fittings can be tightened with this tool.

Avant de commencer l'assemblage, veuillez contrôler si tous les objets indiqués sont présents. Tous les vis peuvent être serrés par cet outil.

Bevor Sie mit dem Aufbau beginnen, kontrollieren Sie ob alle auf der Zeichnung angegebenen Teile vorhanden sind. Bitte verwenden Sie zur Montage einen Kreuzschraub-zehner und den beiliegenden Insechschraubenschlüssel.

Werte-nr. Part no. Ref No

Siehe Bild-nr. See picture no. Image no

Stück Qty. Qty. Qte. Mess Dim. Dim.

4301-2208631-40	2 stick/pcs.		4301-2208631-40	2 stick/pcs.	
3922-060181	4 stick/pcs.		3922-060181	4 stick/pcs.	
Z28	M6/Ø10x18mm		Z28	M6/Ø10x18mm	
3913-06110	4 stick/pcs.		3913-06110	4 stick/pcs.	
Z29	M6x110 mm.		Z29	M6x110 mm.	
	4033-004		4033-004	1 stick/pcs.	
	4 mm.			4 mm.	

Z1, Z2, Z5 Fittings in single / bunk bed box.
 Z1, Z2, Z5 Beschläge im Einzel- / Etagenbett Karton.
 Z1, Z2, Z5 Raccords en lit simple / lit superposé.
 Z1, Z2, Z5 Fittings in het enkelspel / stapelbed boxen.

<p>1</p> <p>Z2 x8 pcs.</p>	<p>Bunk bed only. Nur Etagen Bett. Lits superposés seulement. Alleen stapelbed</p>
<p>2a</p> <p>Z29 x2 pcs. Z5 x2 pcs. Z1 x2 pcs. Z28 x2 pcs.</p>	<p>2b</p> <p>Z29 x2 pcs. Z5 x2 pcs. Z1 x2 pcs. Z28 x2 pcs.</p>
<p>3a</p> <p>Z29 x2 pcs. Z5 x2 pcs. Z1 x2 pcs. Z28 x2 pcs.</p>	<p>3b</p> <p>Z29 x2 pcs. Z5 x2 pcs. Z1 x2 pcs. Z28 x2 pcs.</p>

80-20604-40

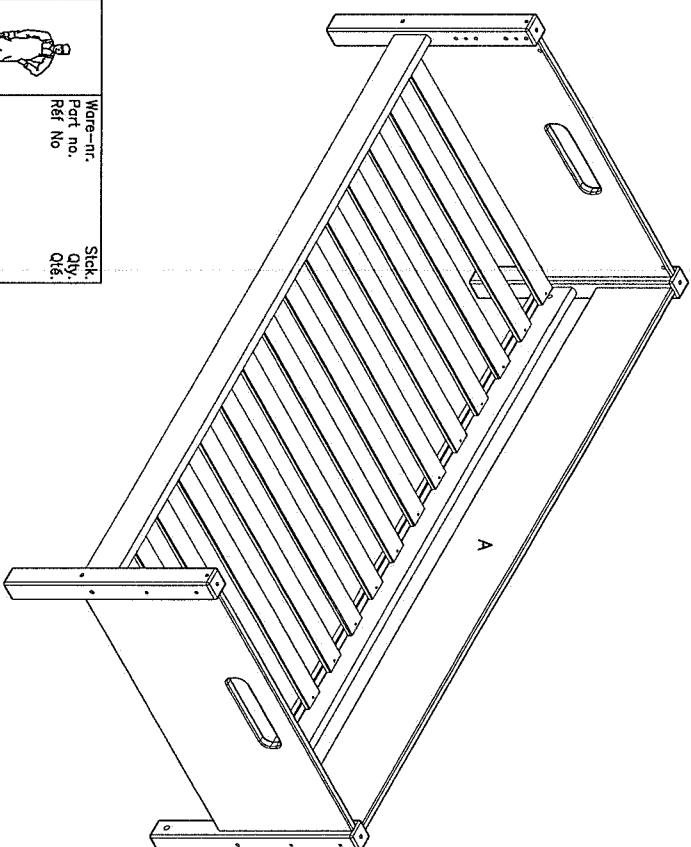

Before assembling this product, please ensure that all the components supplied comply with the list on this page. All Screw-type fittings can be tightened with this tool.



4301-2219675-40

1 stck./pcs.

Avant de commencer l'assemblage, veuillez contrôler si tous les objets indiqués sont présents dans votre paquet d'origine.

Bevor Sie mit dem Aufbau beginnen, kontrollieren Sie ob alle auf der Zeichnung angegebenen Teile vorhanden sind. Bitte verwenden Sie zur Montage einen Kreuzschraub-zähler und den beiliegenden Innensechskantschlüssel.



Ware-nr.
Part no.
Réf No

Stck.
Qty.
Qté.

Stiehe Bild-nr.
See picture no.
Image no

Mass
Dim.
Dim.

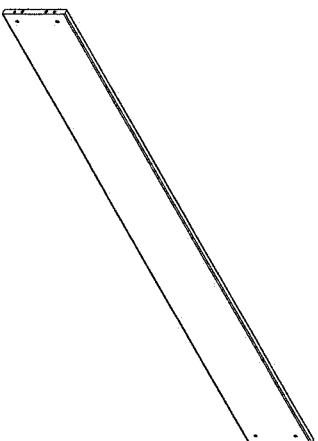

1967x248x22

3930-10050 4 stck./pcs. 3922-060181 4 stck./pcs.



Z22 Ø10x50 mm. Z28 M6/Ø10x18mm

3913-06110 4 stck./pcs. 4033-004 1 stck./pcs.

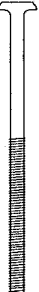

Z29 M6x110 mm. 4 mm.

Ref.no. 44-01978-40 A1 Stand: 290621 Page 1-2 (80-20604-40)

See assembly instruction in box no. 80-20101-40

Voir notice de montage dans la caisse no. 80-20101-40

Stiehe Aufbauanleitung im karton no. 80-20101-40

Zie voor de montage-instructie pakketnr. 80-20101-40

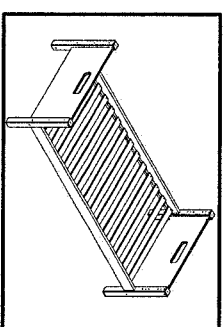

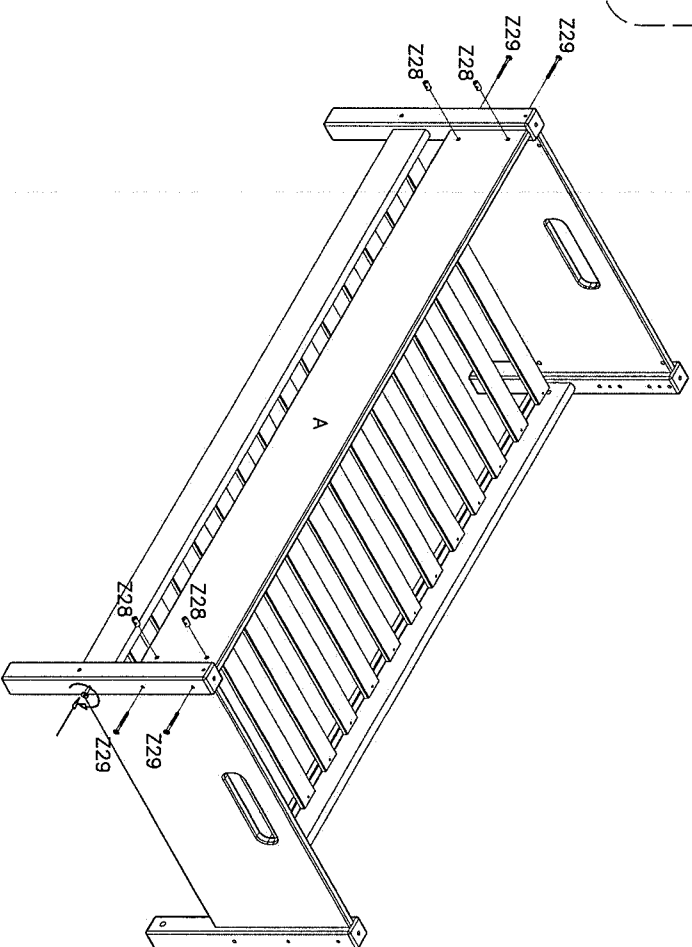
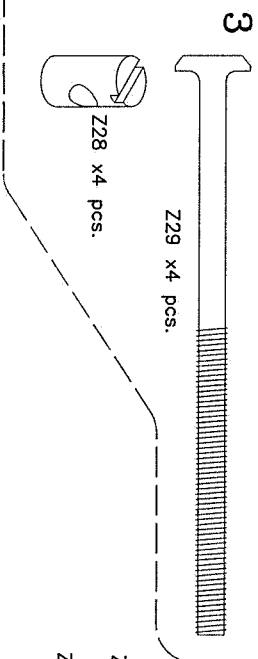
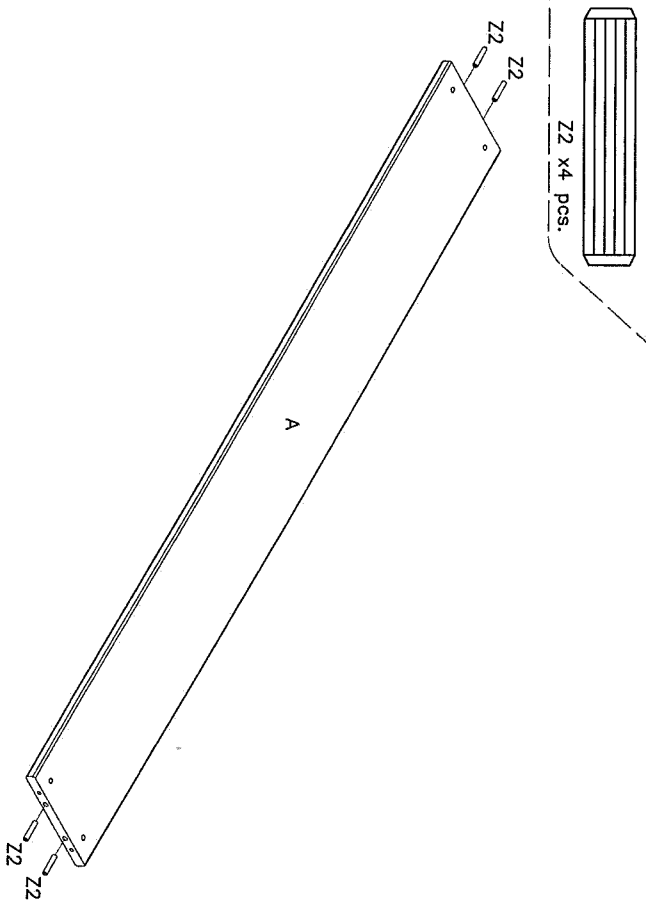
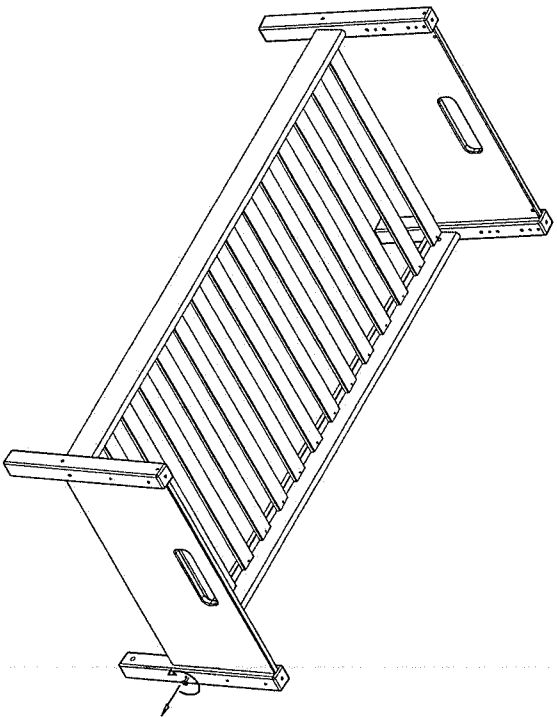

80-20605-40

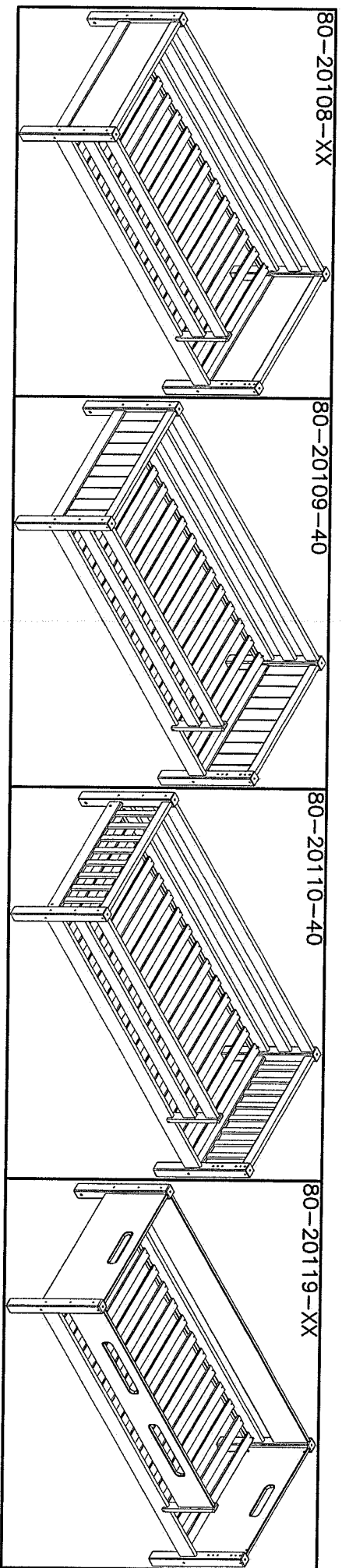

Before assembling this product, please ensure that all the components supplied comply with the list on this page. All Screw-type fittings can be tightened with this tool.

Avant de commencer l'assemblage, veuillez contrôler si tous les objets indiqués sont présents. Tous les vis peuvent être serrés par cet outil.

Bevor Sie mit dem Aufbau beginnen, kontrollieren Sie ob alle auf der Zeichnung angegebenen Teile vorhanden sind. Bitte verwenden Sie zur Montage einen Kreuzschraubenzieher und den beiliegenden Insechschlüssel.

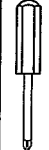

Wart-nr.
Part no.
Ref No

Siehe Bild-nr.
See picture no.
Image no

Mess
Qty.
Qte.
Dim.
Dim.

4301-2215711-40

1571x248x22

13922-060181

12-02603611-40

361x65x26

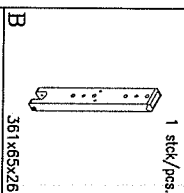
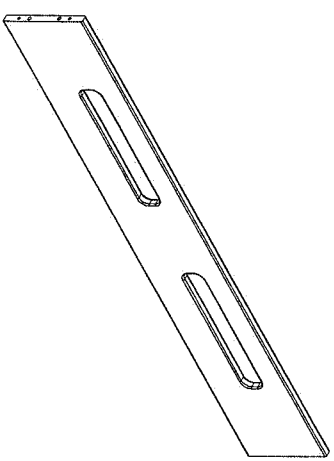

A

3930-10050 4 stick/pcs



Z22

3901-40030 2 stick/pcs



Z4

3922-060181 4 stick/pcs

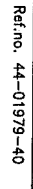

M6/ø10x18mm



Z28

3913-06110 2 stick/pcs



Z29

3913-06070 2 stick/pcs

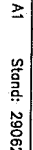

M6x70 mm

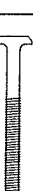

Z30

4033-004 1 stick/pcs



Z29

M6x110 mm

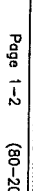

1571x248x22

13922-060181

3913-06110

3913-06070

M6x70 mm

4033-004

M6x110 mm

4 mm

See assembly instruction in box no. 80-20101-40

Voir notice de montage dans la caisse no. 80-20101-40

Siehe Aufbauanleitung im karton no. 80-20101-40
Zie voor de montage-instructie pakkeotr. 80-20101-40

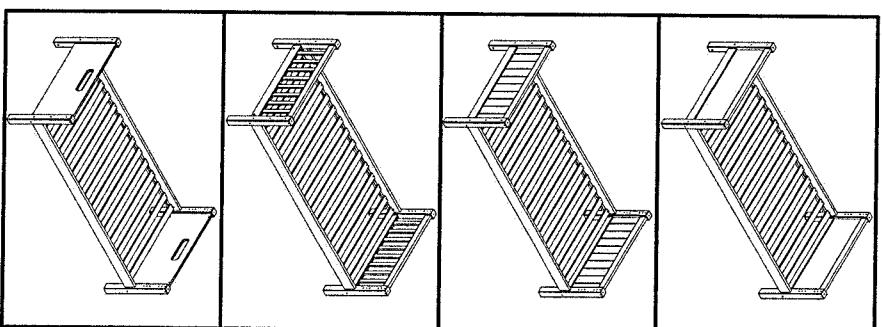

1

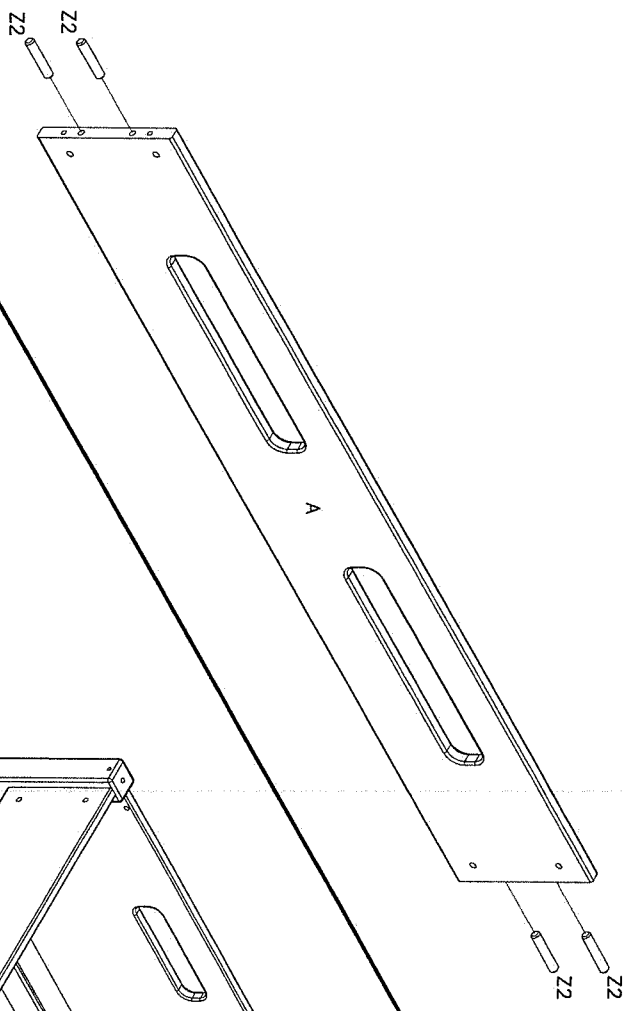
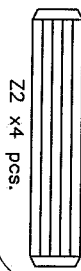



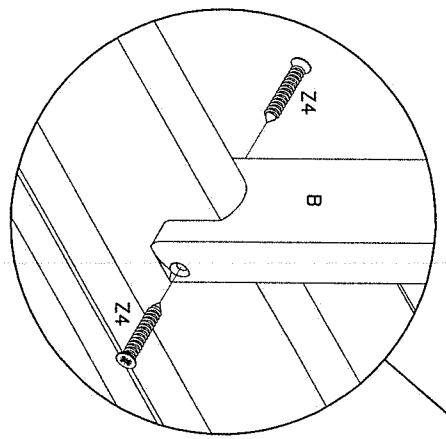
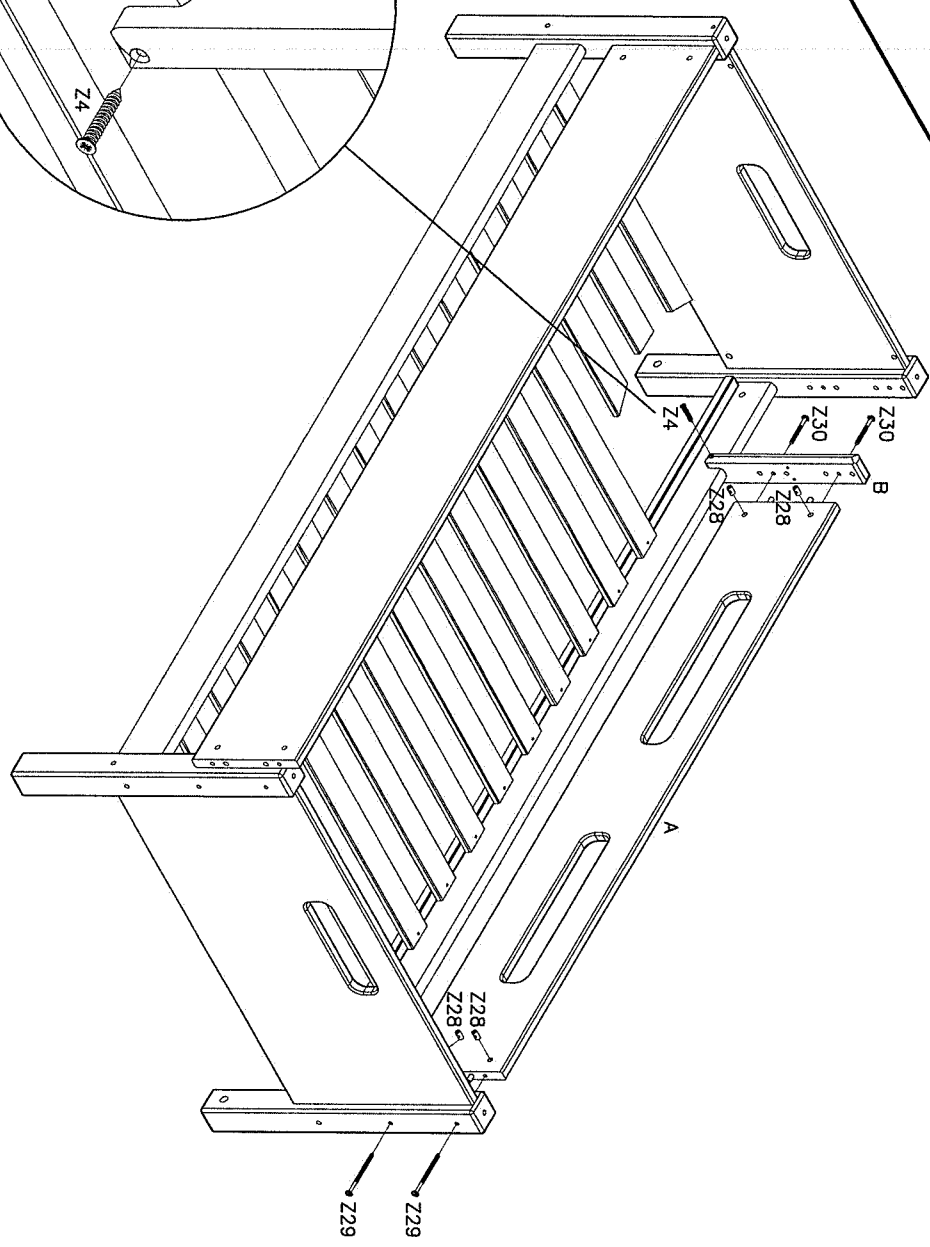
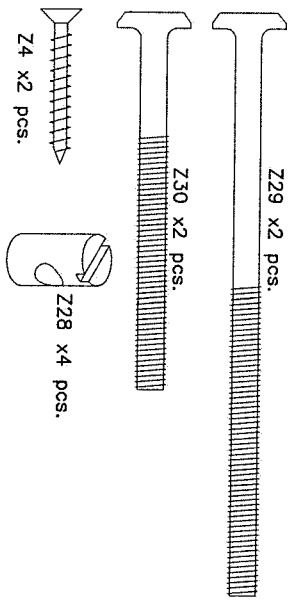



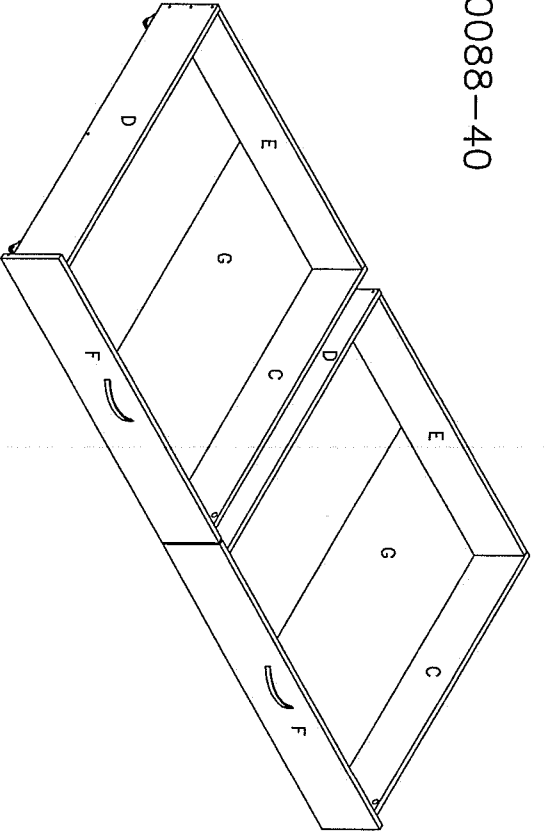



2



82-20088-40

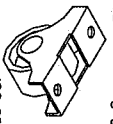
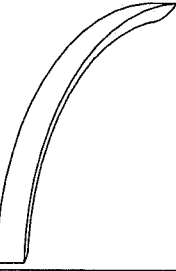

Before assembling this product, please ensure that all the components supplied comply with the list on this page. All Screw-type fittings can be tightened with this tool.		Avant de commencer l'assemblage, veuillez contrôler si tous les objets indiqués sont présents. Tous les vis peuvent être serrés par cet outil.		Bevor Sie mit dem Aufbau beginnen, kontrollieren Sie ob alle auf der Zeichnung angegebenen Teile vorhanden sind. Bitte verwenden Sie zur Montage einen Kreuzschraubenzieher und den beiliegenden Inmensschlüssel.		Werte-nr. Stock no. Ref. No.		Stück Qty. QTY.	
				 		 		Siehe Bild-nr. See picture nr. Image no. Mess Dim. Dim.	
12-01508821	2 stick/pcs	15-015088981-40	2 stick/pcs	15-01508821-40	2 stick/pcs	1309-030893			
A	882x65x15 mm 12-01508791-40 2 stick/pcs	C	898x170x15 mm 15-01508982-40 2 stick/pcs	E	882x170x15 mm 15-01509753-40 2 stick/pcs	G	893x892/446x3 mm		
B	879x45x15 mm	D	898x170x15 mm	F	975x172x15 mm				
3901-40040	16 stick/pcs	3901-40060	6 stick/pcs	3902-35015	16 stick/pcs	3903-40035	6 stick/pcs	4001-010	2 stick/pcs
Z1	4.0x40 mm 3930-08030 8 stick/pcs	Z2	4.0x60 mm 3933-15010 8 stick/pcs	Z3	3.5x15 mm 4020-005 8 stick/pcs	Z4	4.0x35 mm 3912-04018 4 stick/pcs	Z9	128 mm
Z5	8x30 mm	Z6	ø15x9.5 mm	Z7	ø7x34 mm	Z8	M4x18 mm	Z10	ø26x28.5 mm
									

(GB): MAINTENANCE INSTRUCTIONS:

Screws and bolts should from time to time be retightened.
CLEANING:
 LACQUERED: Wooden, lacquered and painted as well as laminated surfaces should be wiped over with a cloth and a mild soap.
 Wipe with a cloth and a mild soap.
 To maintain the natural life in the furniture which is provided by the oil treatment, we recommend an oil aftercare of the furniture 1-2 times a year. The colourless natural oil for maintenance of oil-treated furniture is available at your local furniture store.

(D): PFLEGEHINWEIS:

Schrauben und Bolzen sollten regelmäßig nachgezogen werden.
REINIGUNG:
 LACKIERTE MÖBEL: Lackierte Holzoberflächen können mit einem sauberen Lappen und mildes Seifenwasser gereinigt werden.
 GEÖLT: MÖBEL: Geölte Holzoberflächen können mit einem sauberen Lappen und mildes Seifenwasser gereinigt werden. Um das natürliche Aussehen Ihres Möbels zu erhalten, empfehlen wir eine jährliche Nachbehandlung der Möbel, kann in Ihrem Möbengeschäft gekauft werden.

(F): CONSEILS D'ENTRETIEN:

Votre lit doit être vérifié périodiquement afin de resserrer les vis.
NETTOYAGE:
 LAQUÉ: Les surfaces bois, laquées, peintes et laminées peuvent être essayées avec un chiffon et un savon doux.
 HUILE: Des surfaces huilées peuvent être nettoyées avec l'eau savonneuse, puis, sécher le bois, nous vous recommandons de traiter avec une huile d'entretien.

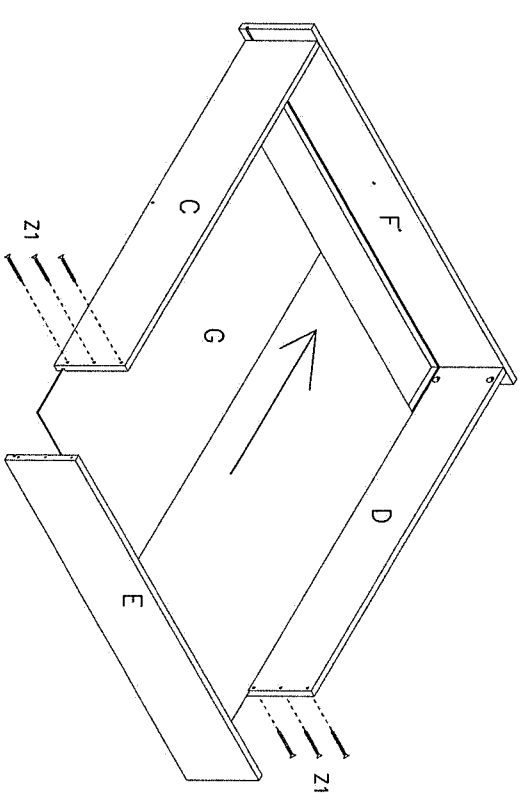
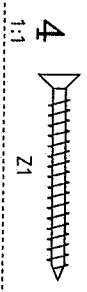
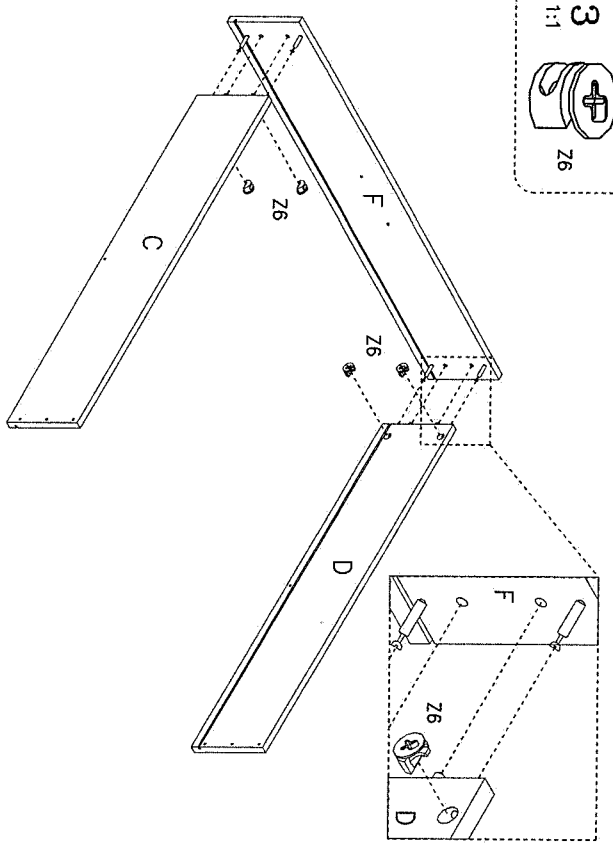
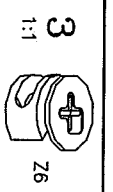
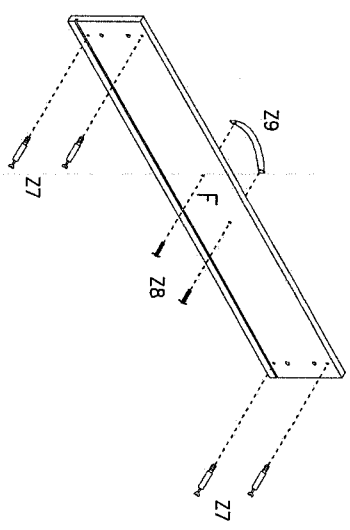
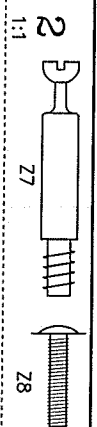
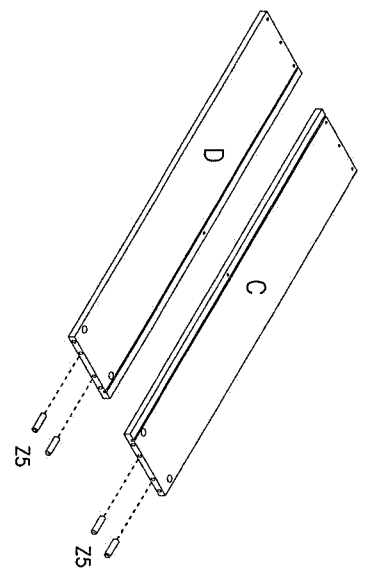
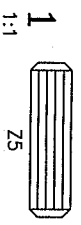

5

