

Art. Nr. 59781054, 82204837

LKZ 40605

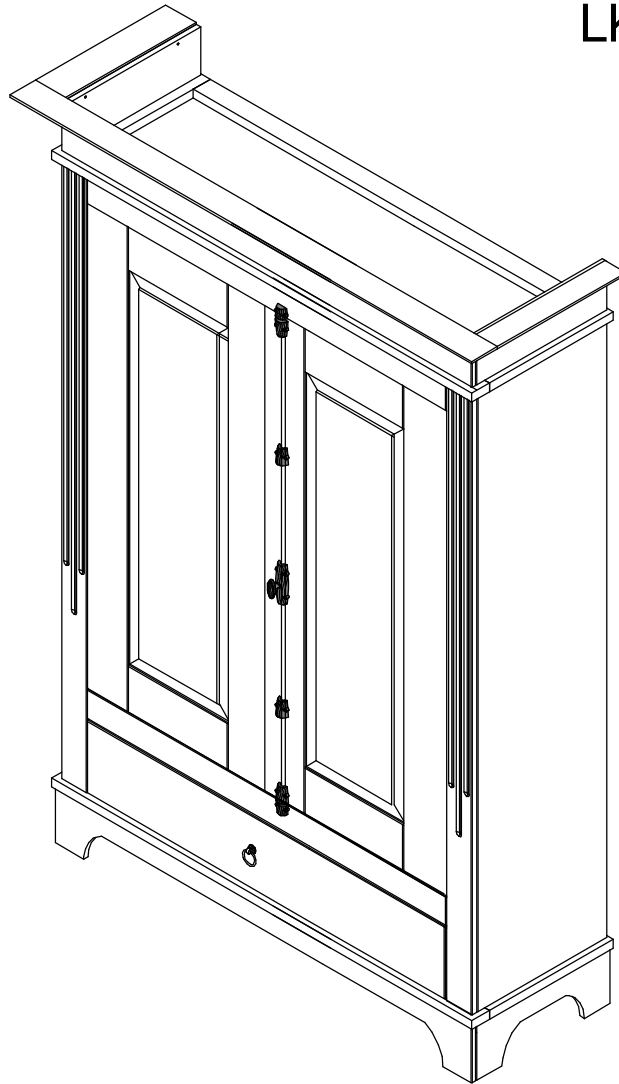

- | | |
|---------------------------------------|-----------------------------------|
| D Montageanleitung | GB Assembly instructions |
| FR Notice de montage | IT Istruzioni di montaggio |
| NL Handleiding voor de montage | PL Instrukcja montażu |
| CZ Montážní návod | SK Návod na montáž |
| HU Szerelési útmutató | RO Instrucțiuni de montaj |
| TR Montaj talimatı | RU Инструкция по монтажу |

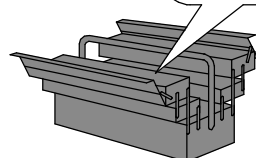
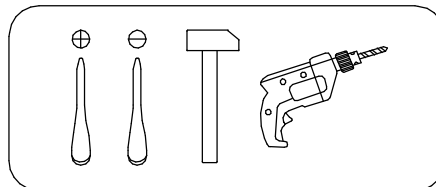
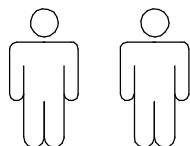

Service · Dienstverlening · Serwis · Servis · Сервисная служба







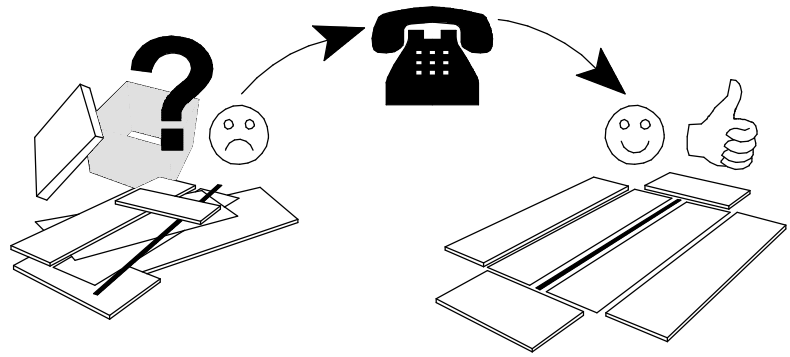
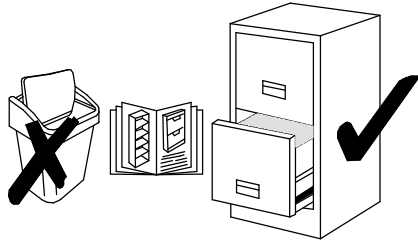



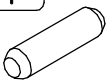

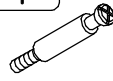





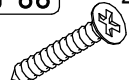



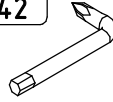

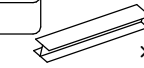
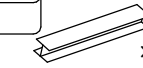

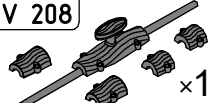
Name · Naam · Nazwa · Isim · Название

Nr. · No. · Номер

Typ · Type · Tip · Тип

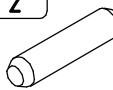

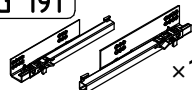
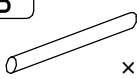
N	Size/MaB (mm)	Qty	✓	N	Size/MaB (mm)	Qty	✓
1	1012x379	2		16	880x80	1	
2	1670x522	1		17	880x80	1	
3	1670x522	1		18	1060x550	1	
4	540x80	1		19	202x66	2	
5	540x80	1		20	1060x150	1	
6	1200x80	1		21	536x150	1	
7	526x130	2		22	536x150	1	
8	336x50	1		23	1032x150	1	
9	1040x130	1		24	1306x437	1	
10	1060x550	1		25	876x196	1	
11	1678x515	2		26	847x347	1	
12	1670x80	1		27	838x160	1	
13	1670x80	1		28	350x160	1	
14	1012x507	1		29	350x160	1	
15	80x40	2		30	1306x437	1	
				31	1276x30	1	

A 1 8x30 x40 	B 1 15x9.5 x77 	C 1 7x24 x77 	D 30 3.5x15 x29 	P 79 M4x22 x1 	H 77  x6
N 1 8x40 x1 	L 40  x4	D 88 4.0x50 x1 	N 18  x1	D 37 3.5x20 x16 	D 13 3.0x15 x6 
J 42  x1	O 17  x50	D 43 3.5x30 x11 	O 10 1440MM x1 	O 10 190MM x1 	H 116  x6
V 208  x1	P 41 6.3x11 x4 	D 47 3.5x35 x4 	D 118 4.5x60 x4 	J 14  x2	V 214  x1
A 2 8x50 x4 	A 11 6x30 x8 	G 191  x1	J 65  x1	N 7  x7	Z 87  x1

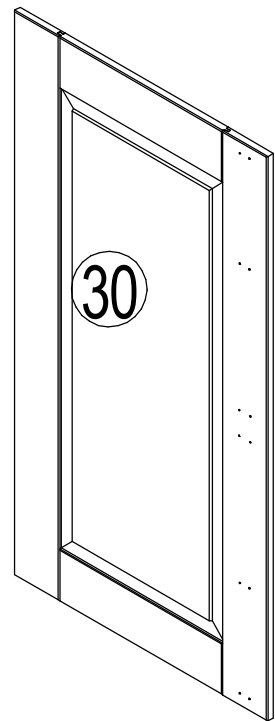
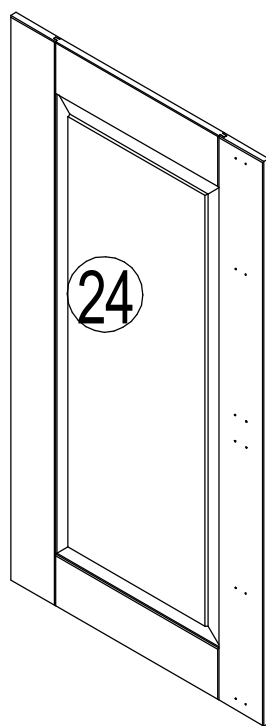
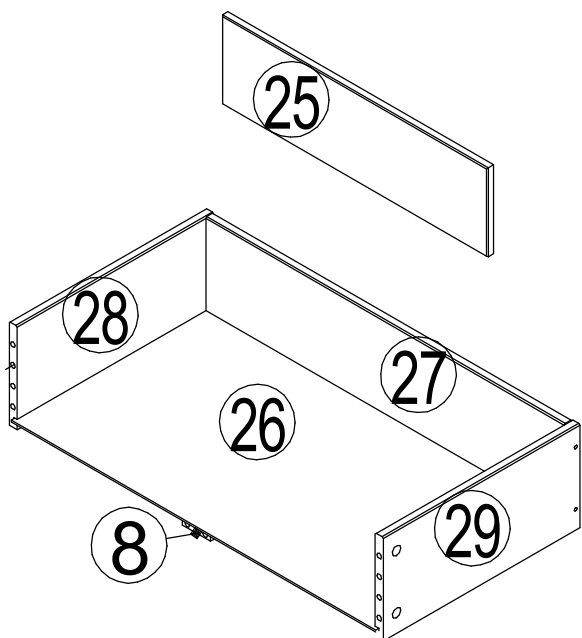
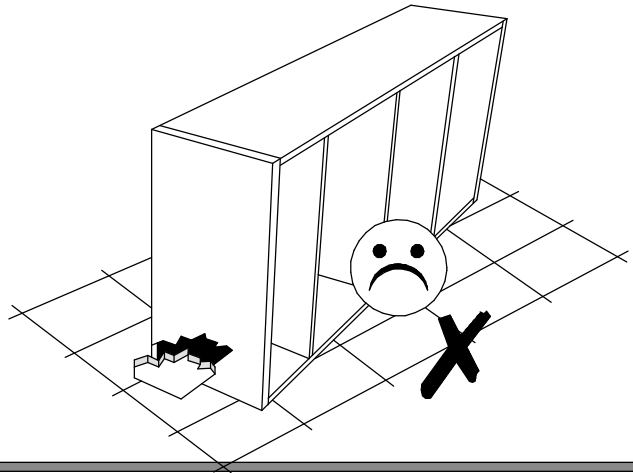
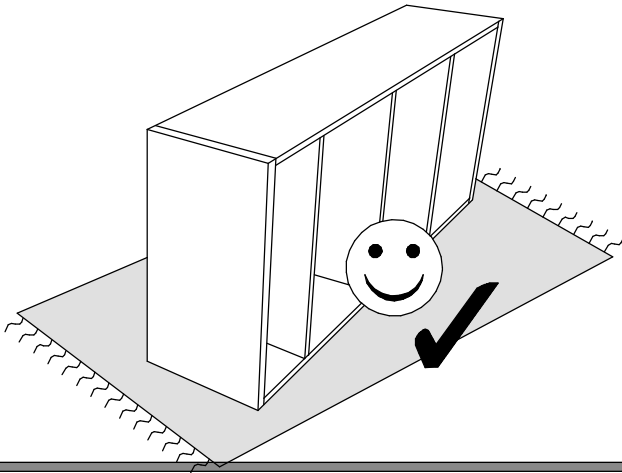

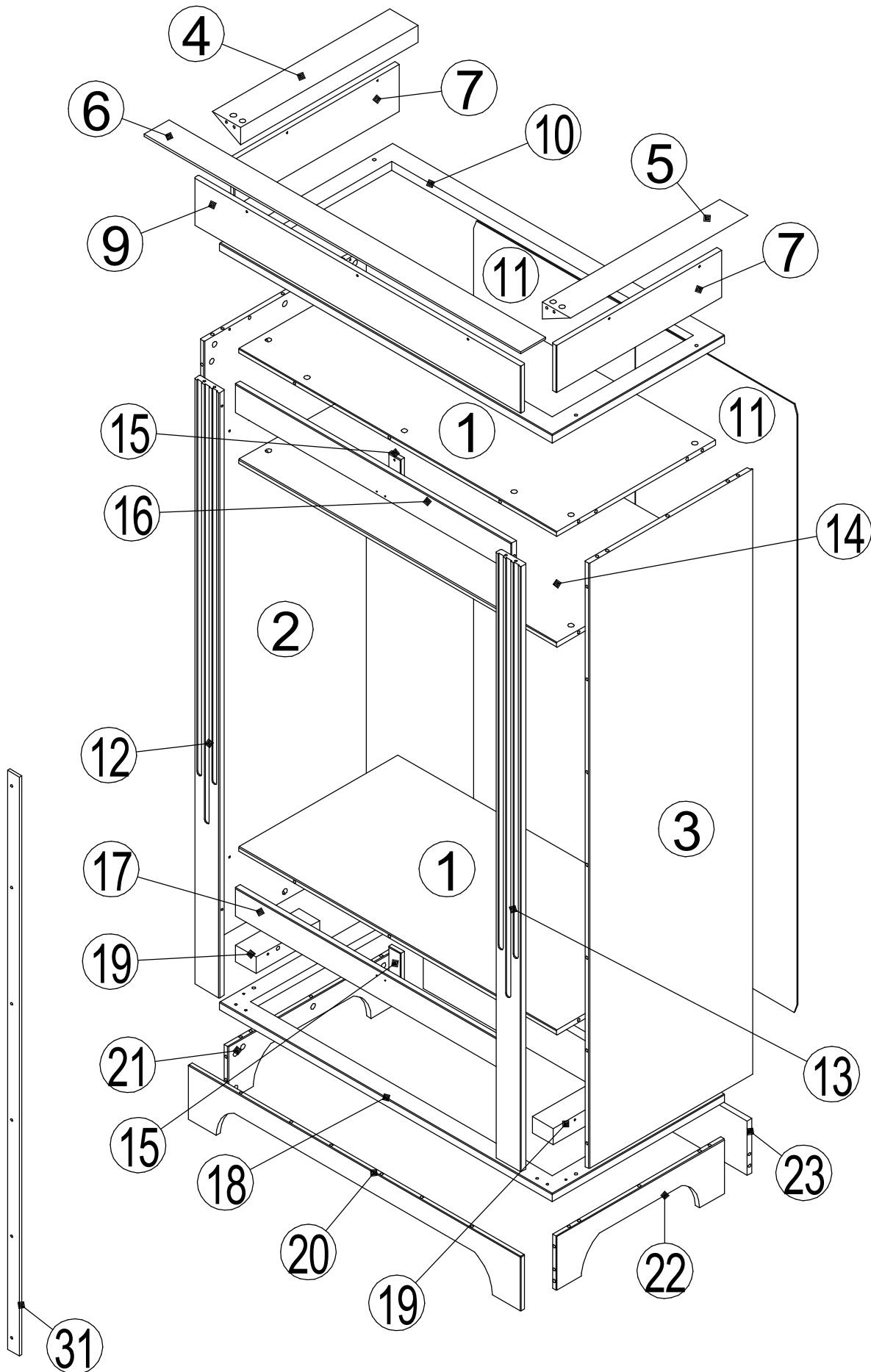

1

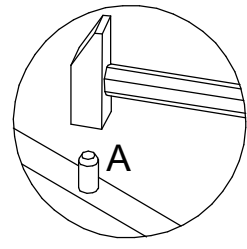
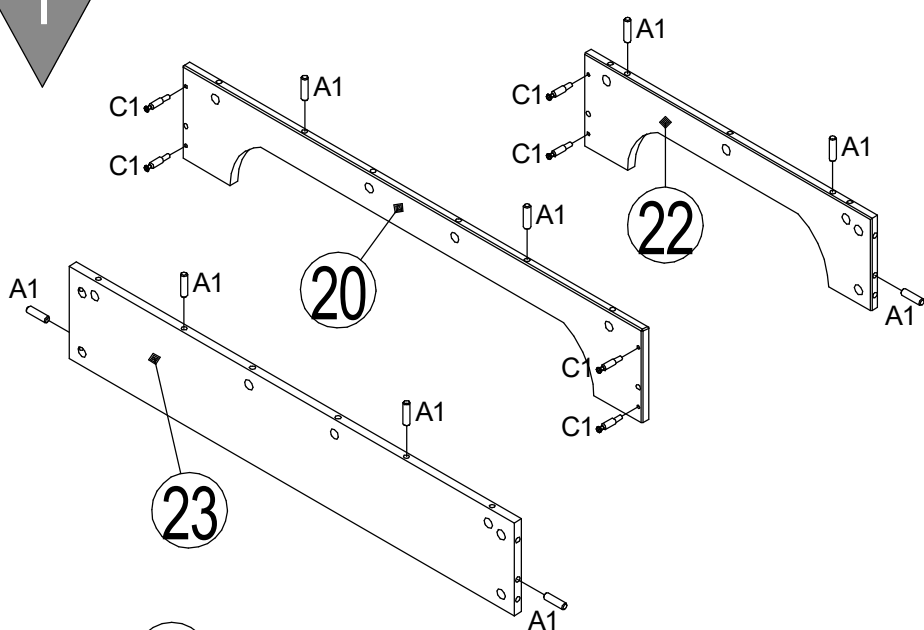

C 1	7x24
	x32
A 1	8x30
	x16
B 1	15x9.5
	x4

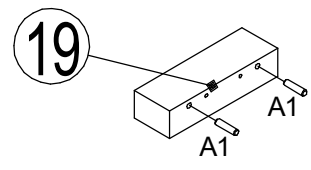
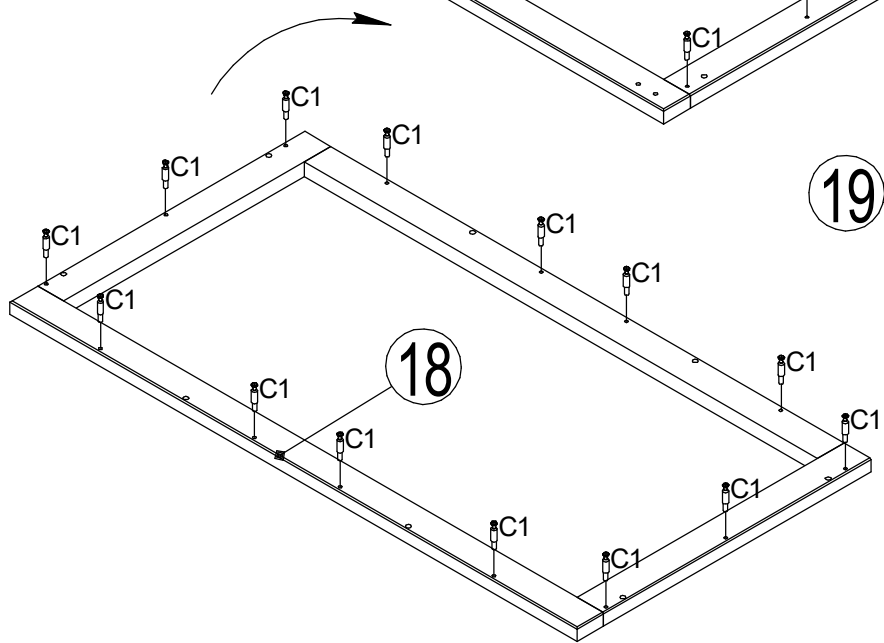
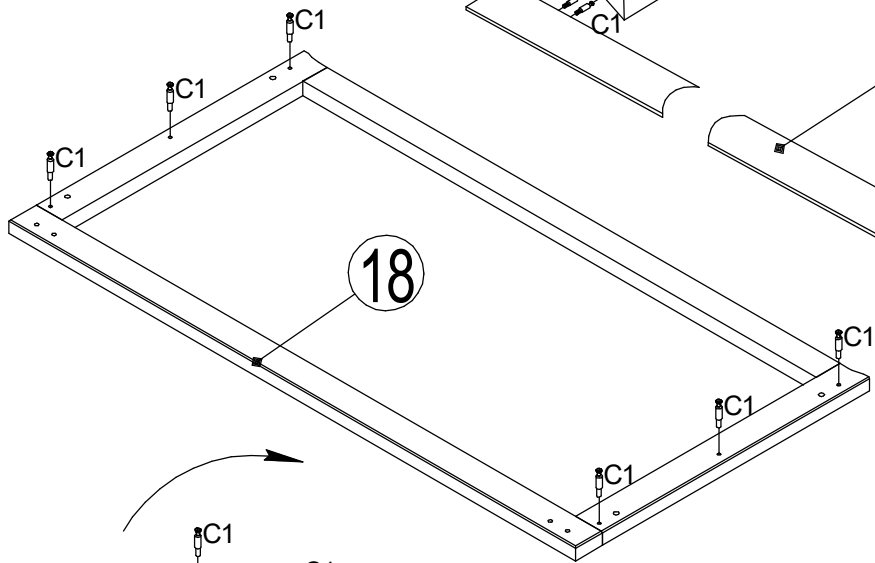
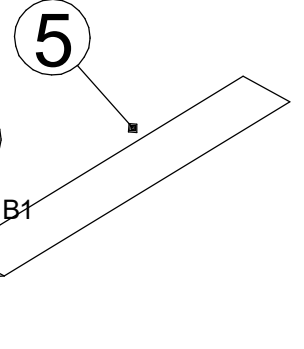
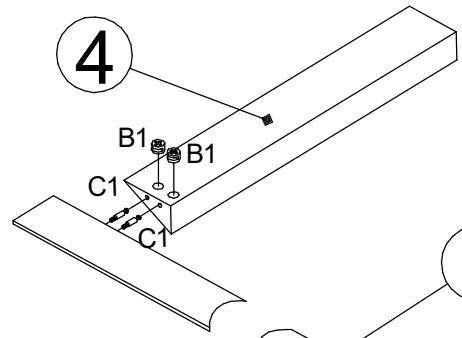
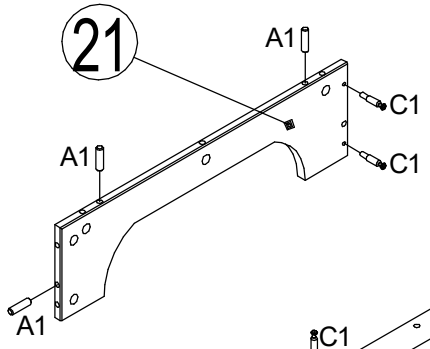

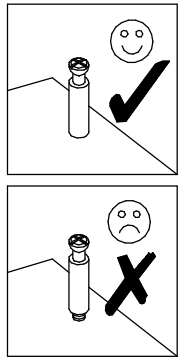

x2



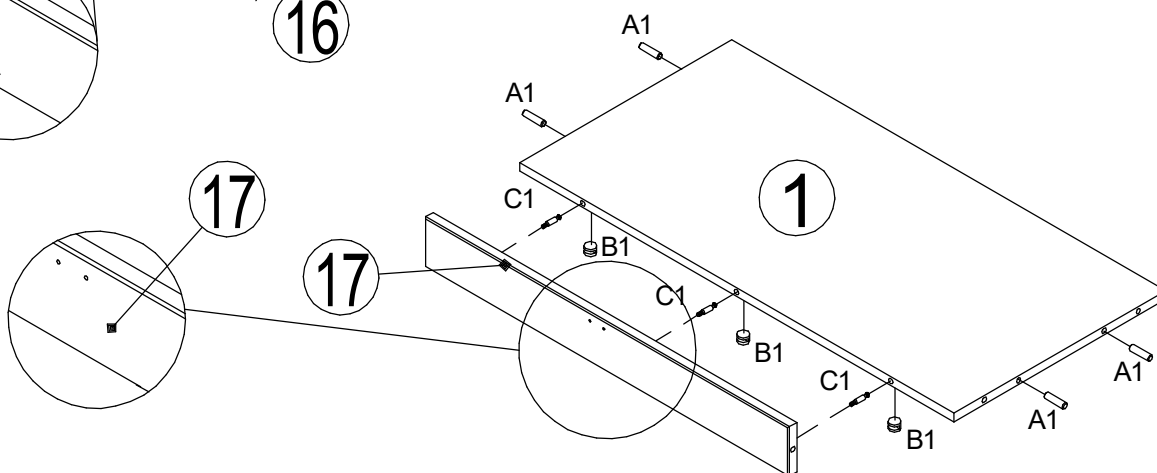
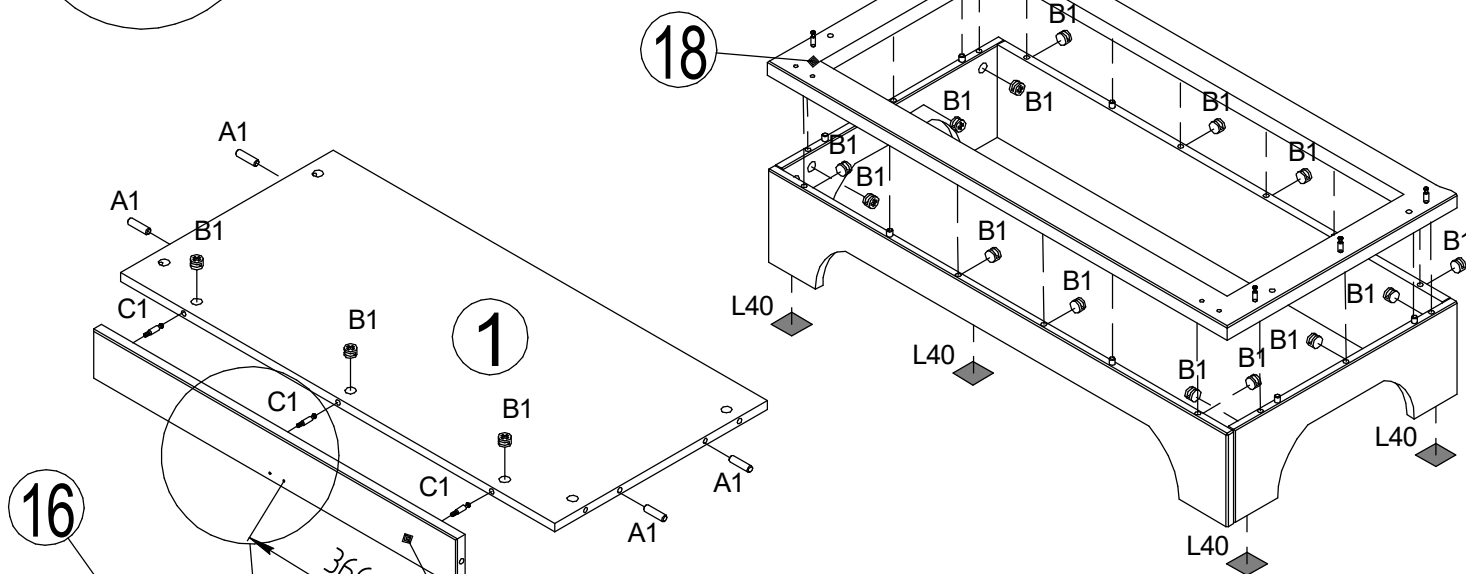
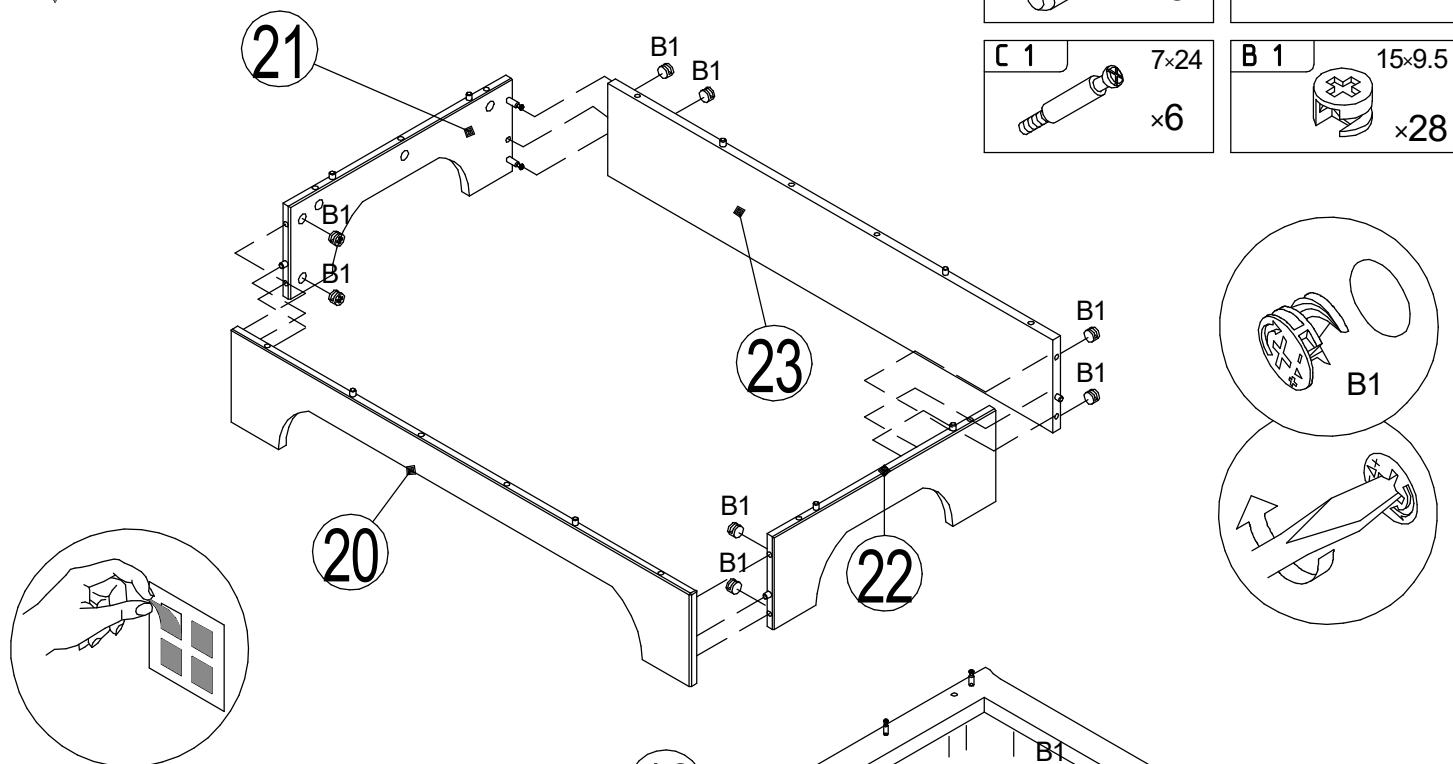

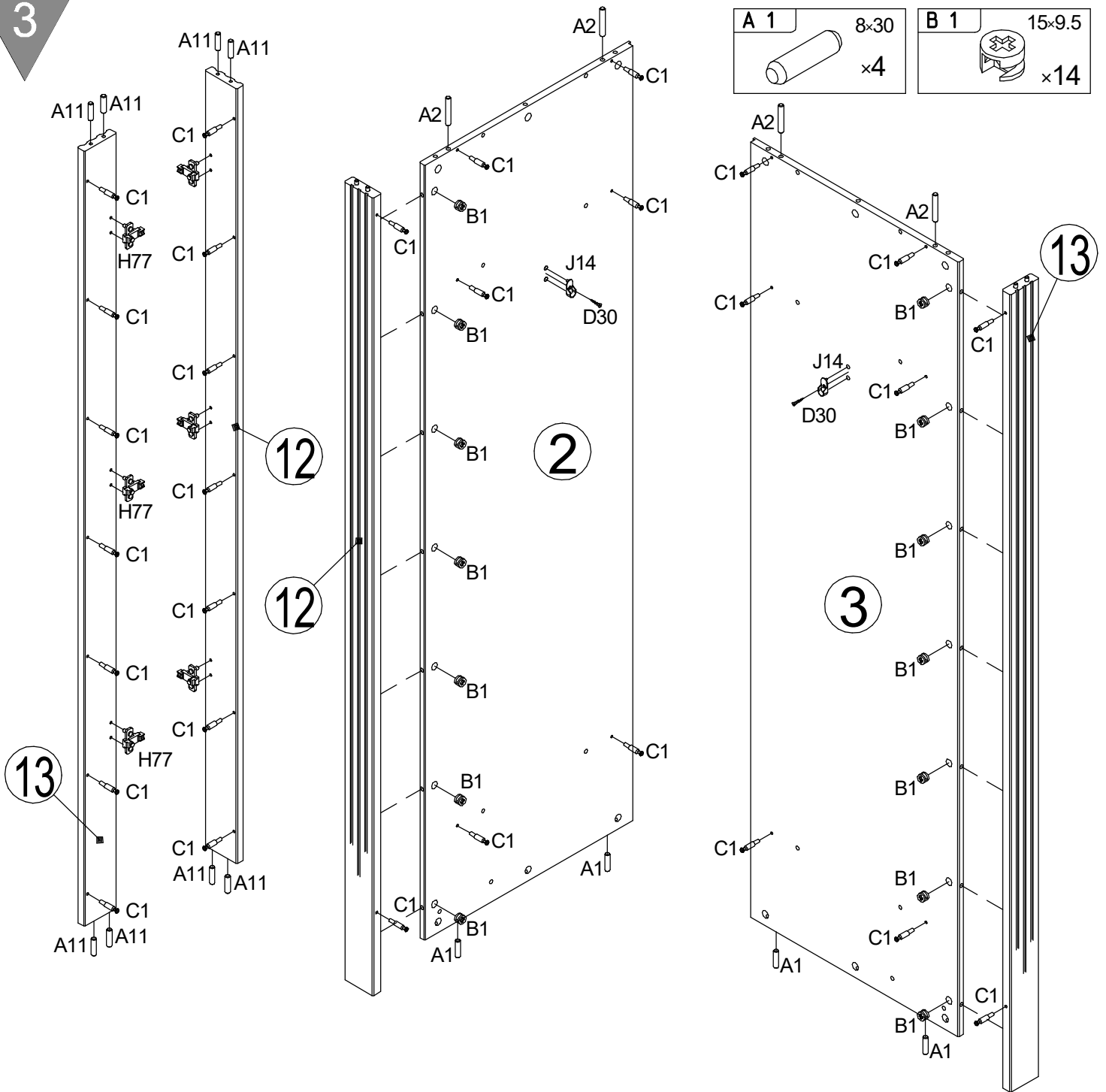
A 1	8x30 x8	L 40	x4
C 1	7x24 x6	B 1	15x9.5 x28







H 77		x6
-------------	--	----

D 30		3.5x15 x2
-------------	---	--------------

J 14		x2
-------------	--	----

A 11		6x30 x8
-------------	---	------------

A 2		8x50 x4
------------	---	------------

C 1		7x24 x30
------------	---	-------------

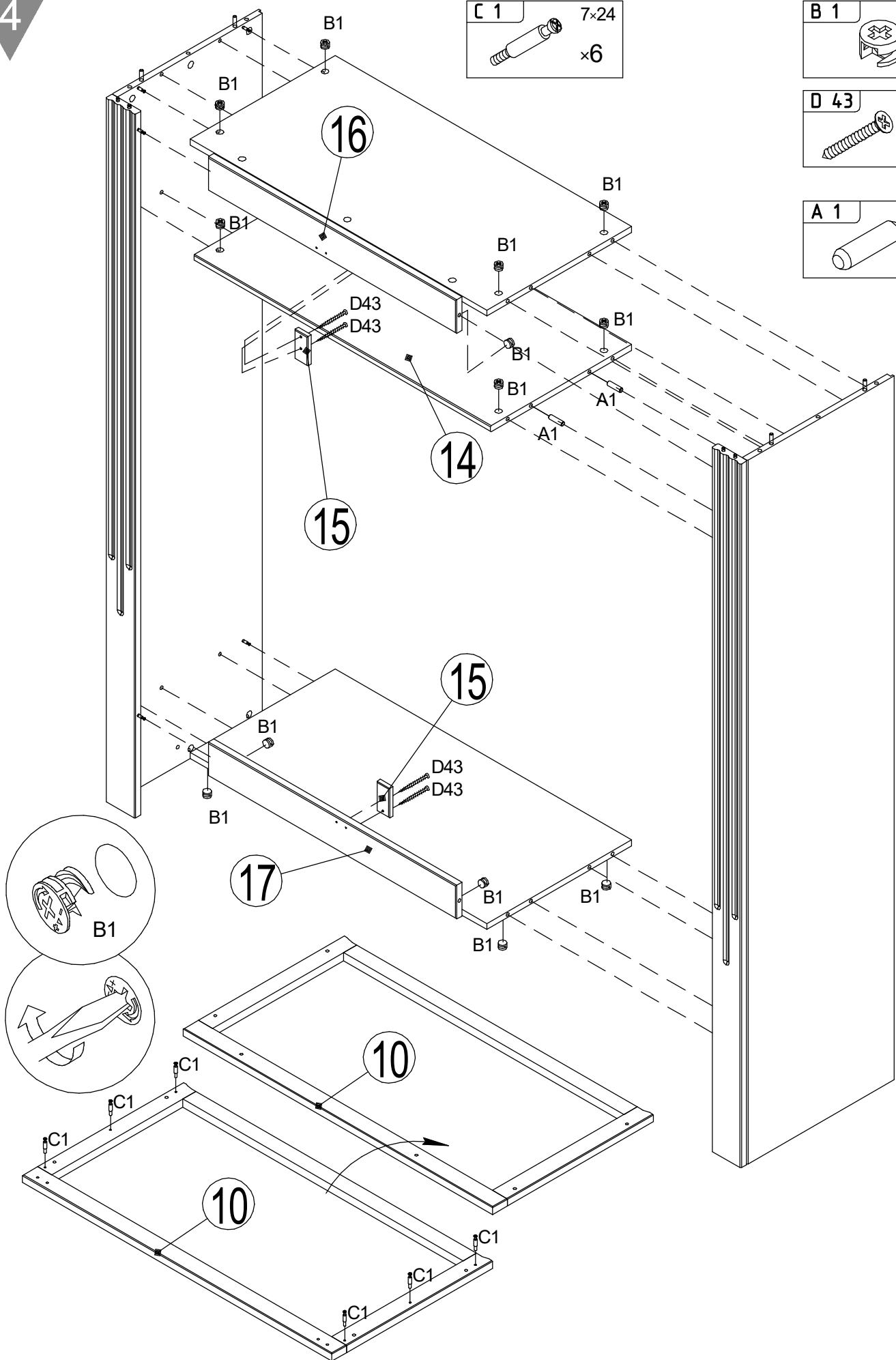
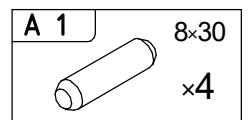
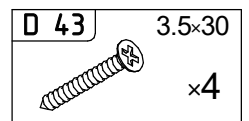
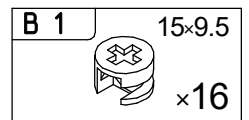
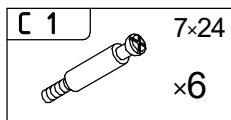

5

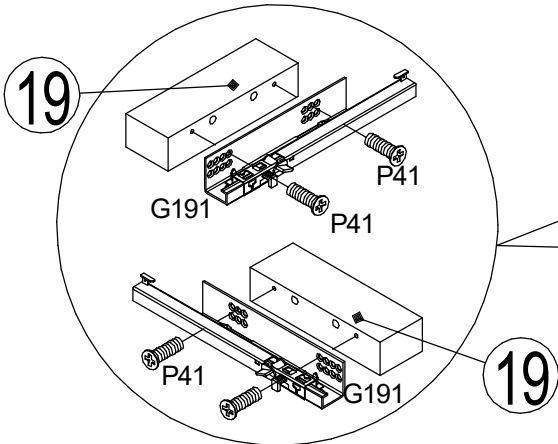
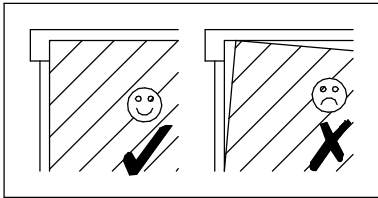
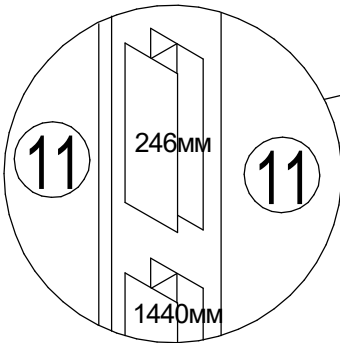
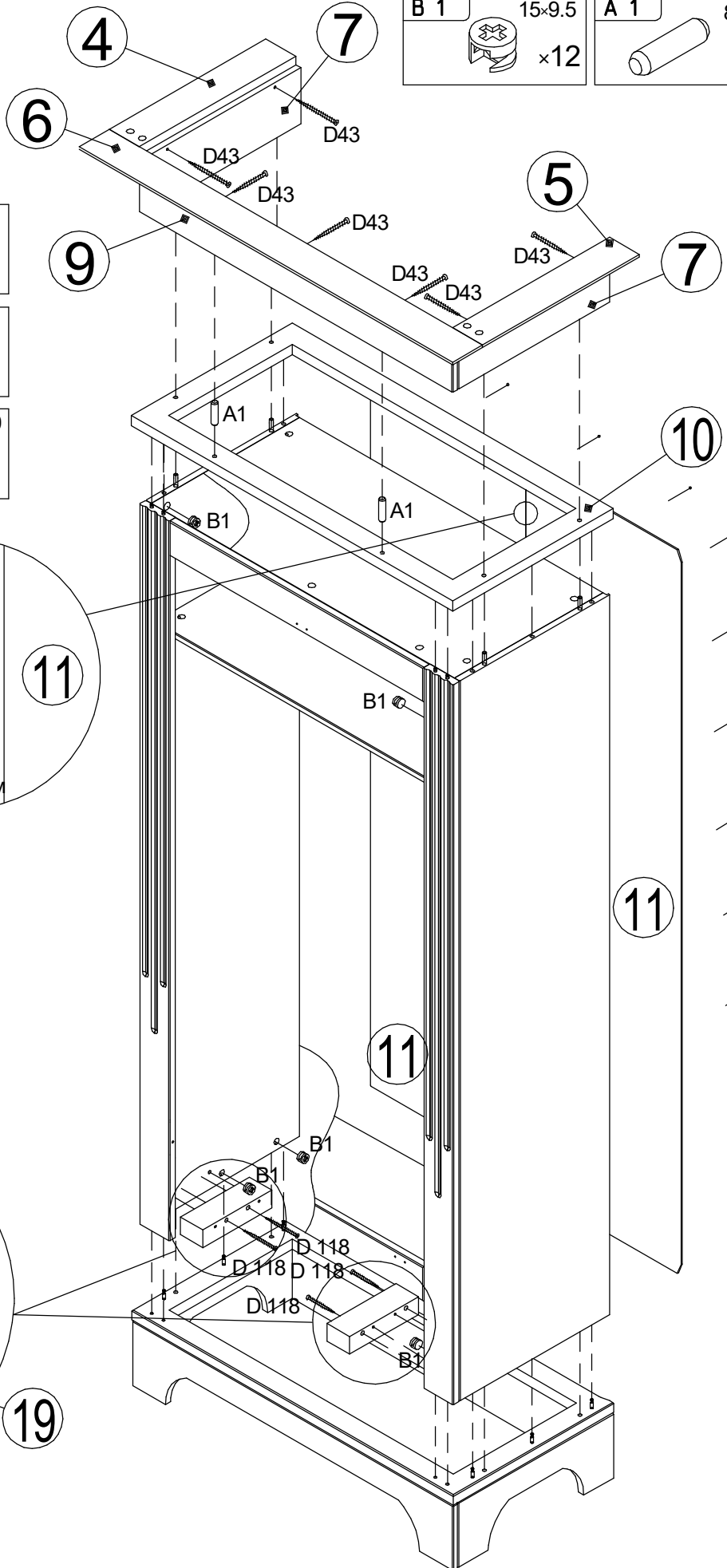
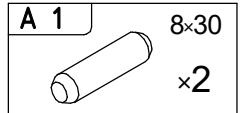
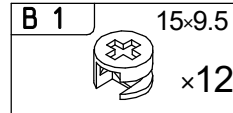
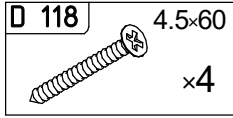
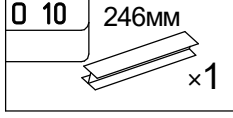
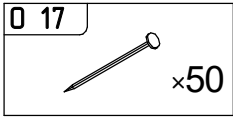
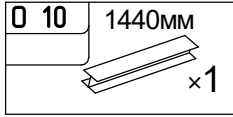
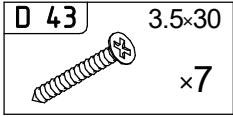
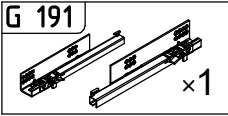
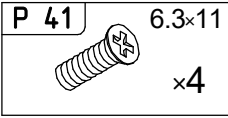

O17

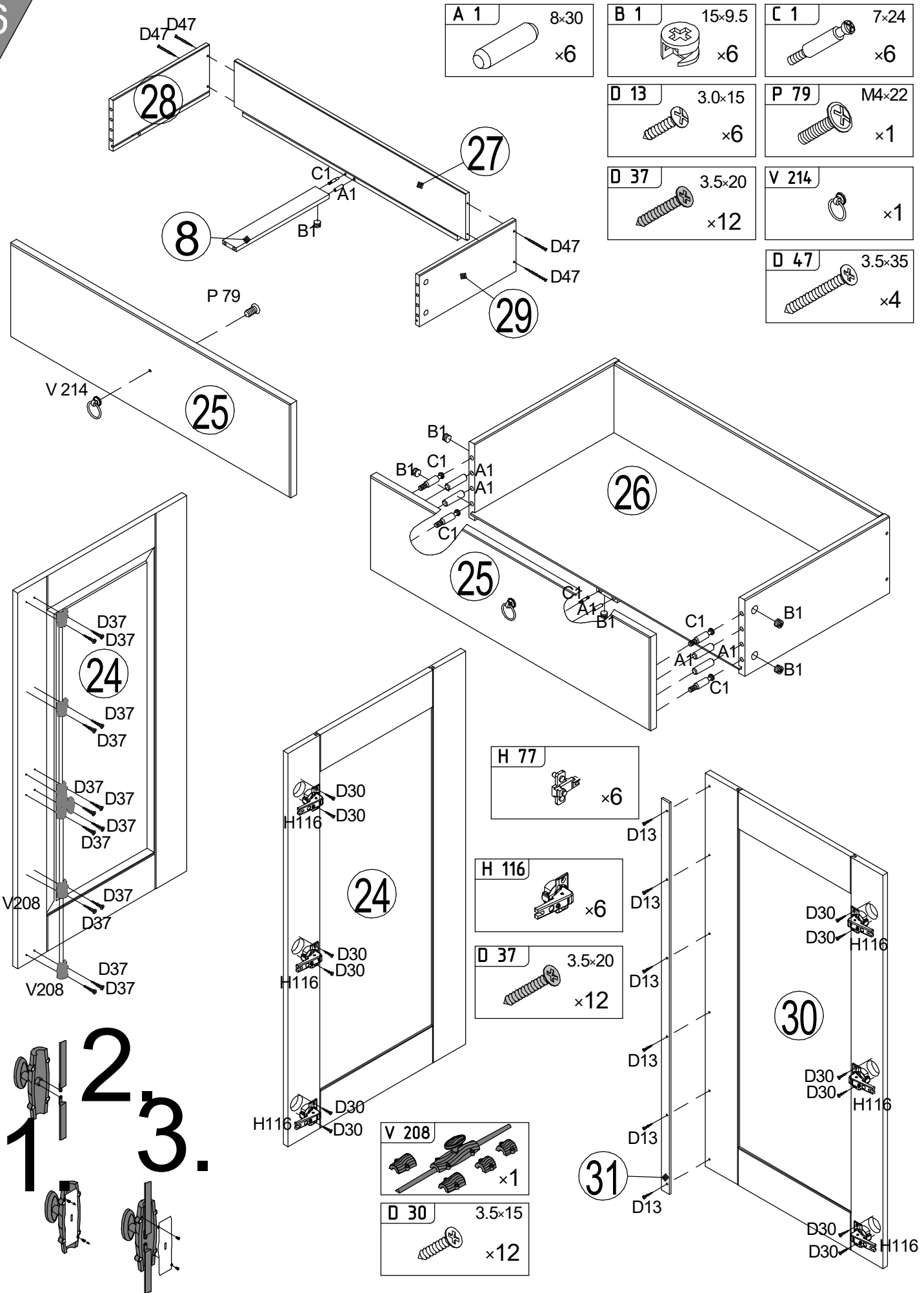

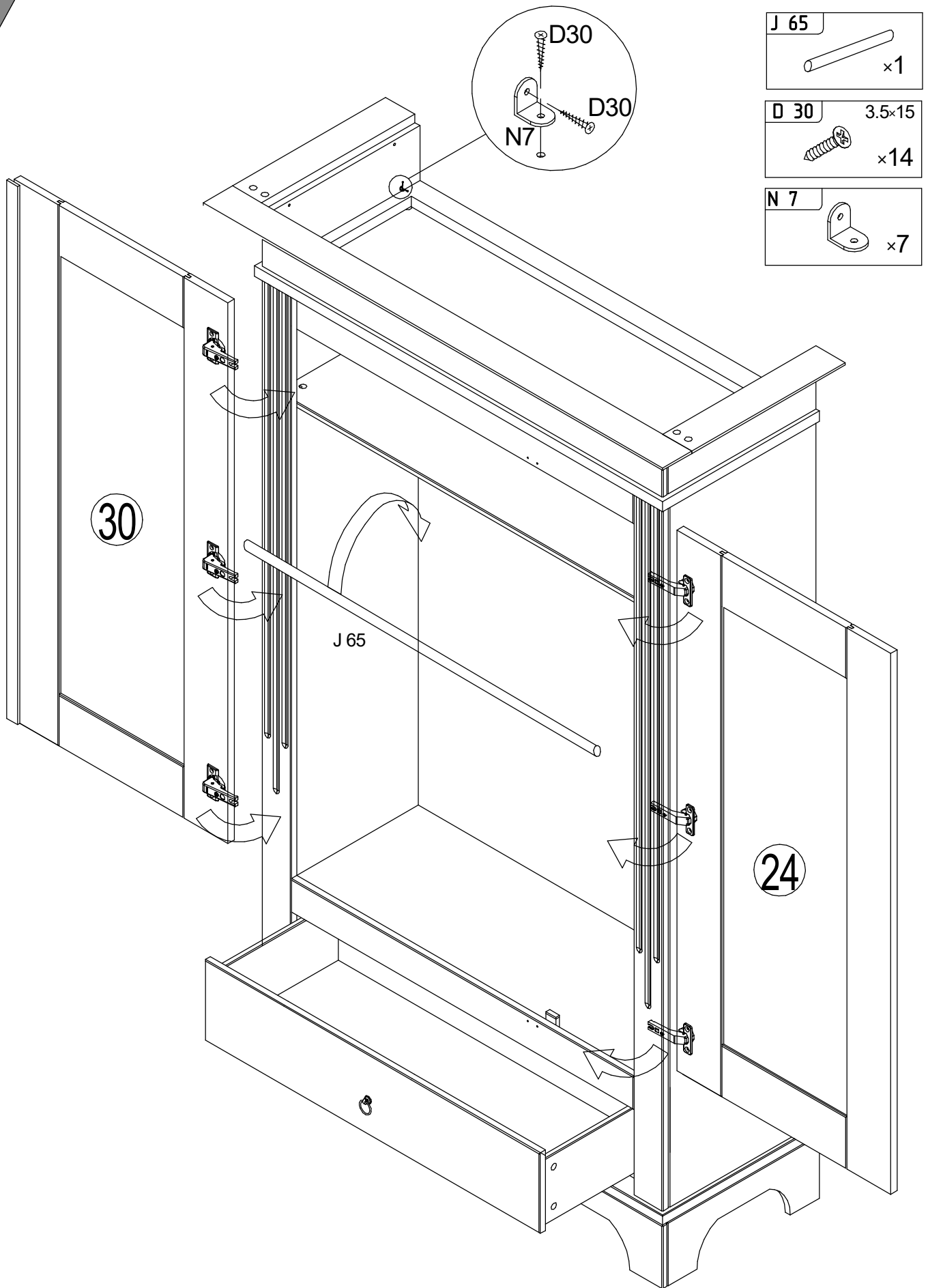

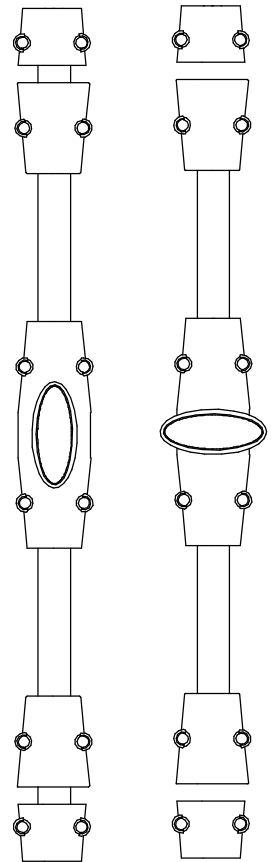
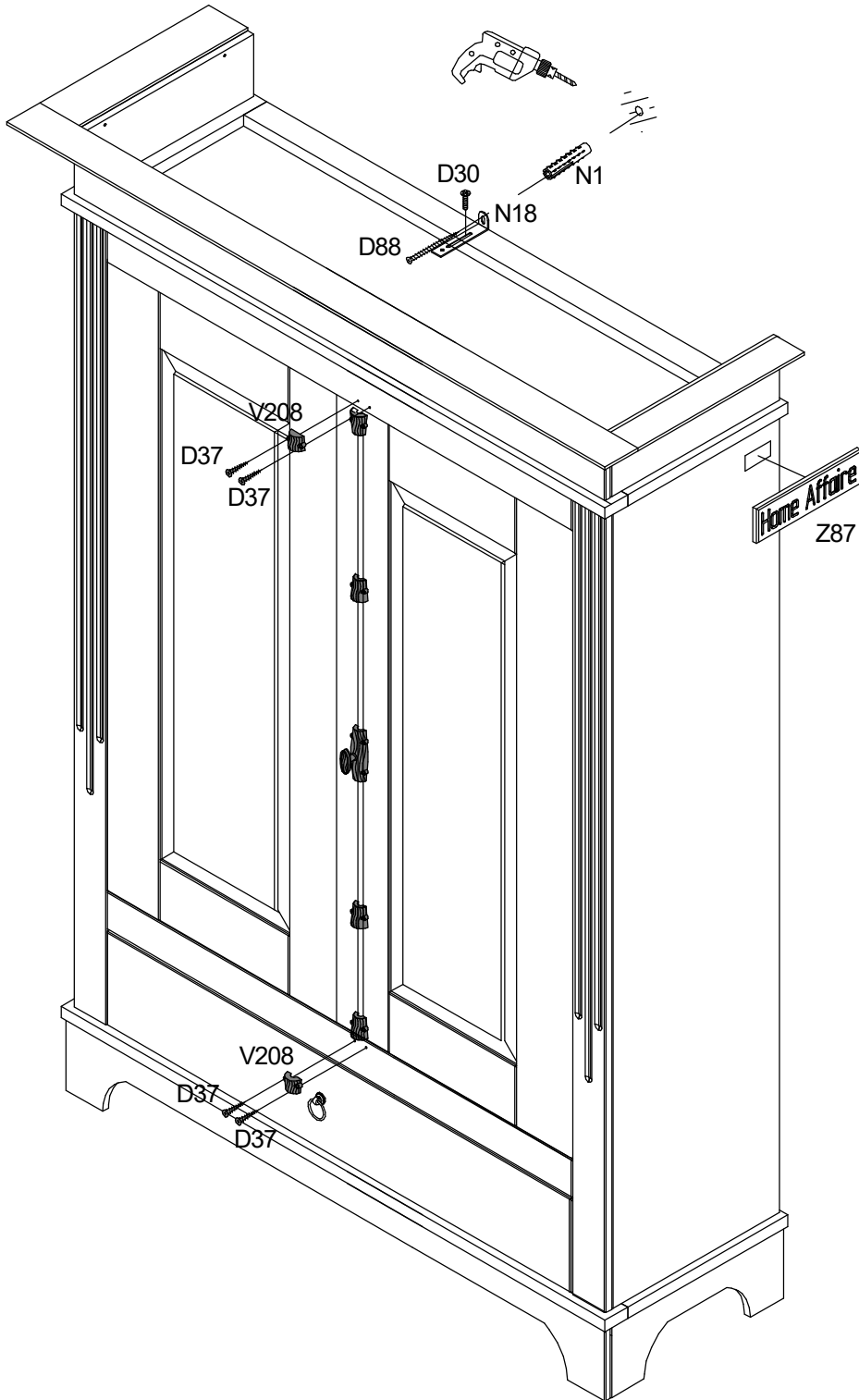
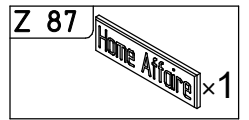
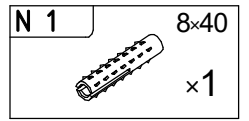
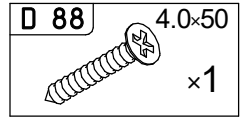
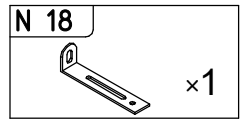
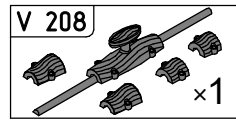
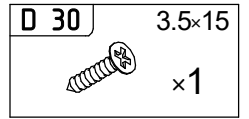
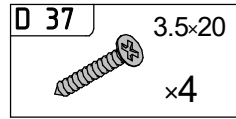



**Achtung • Attention • Attenzione
Opgelet • Uwaga • Pozor • Figyelem
Atenție • Dikkat • Внимание**



(D)	Wandbefestigung dient als Kippschutz – unbedingt anbringen! Bei einigen Wandtypen kann ein Spezialdübel erforderlich sein!
(GB)	The wall fastening serves to prevent tipping – be absolutely sure to mount it! For certain wall types, a special wall plug may be necessary!
(FR)	La fixation murale sert de protection contre le basculement – à installer impérativement ! Pour certains types de murs il faut des chevilles spéciales !
(IT)	Il fissaggio alla parete serve da protezione anti-ribaltamento – attaccarla assolutamente! Per alcune strutture di parete può essere necessario un tassello speciale!
(NL)	Bevestiging aan de muur dient als kantelbescherming – zeker en vast bevestigen! Bij enkele muurtypes is een speciale plug misschien vereist!
(PL)	Mocowanie do ściany jest jednocześnie zabezpieczeniem przed przewróceniem – koniecznie zamontować! Do niektórych rodzajów ścian koniecznie zastosować specjalne kołki mocujące.
(CZ)	Montáž na stěnu slouží jako ochrana proti převrnutí – bezpodmienečně umístěte! U některých typů stěn může být zapotřebí speciální hmoždinka!
(SK)	Upevnenie na stenu slúži ako ochrana proti prevráteniu – bezpodmienečne použite! Pre niektoré druhy stien môže byť potrebná špeciálna hmoždinka!
(HU)	A terméket a falhoz kel rögzíténi, különben az felborulhat! Egyes faltípusoknál speciális tiplit kell használni!
(RO)	Sistemul de fixare la perete servește ca protecție la răsturnare – de montat obligatoriu! Pentru unele tipuri de pereți este posibil să fie necesar un diblu special!
(TR)	Duvardaki sabitleme, devrilmeye karşı bir emniyet tedbiridir ve mutlaka monte edilmelidir! Bazı duvar tiplerinde bunun için özel bir dübel gerekli olabilir!
(RU)	Обязательно установите крепление на стене во избежание опрокидывания! Для некоторых типов стен может потребоваться специальный дюбель!