

1089

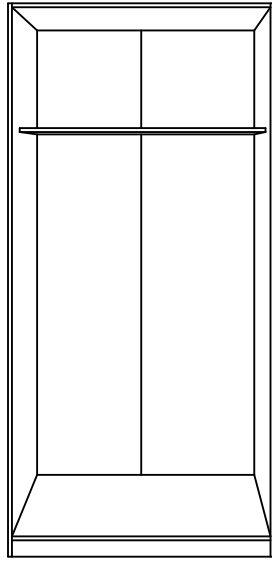

1

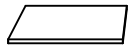
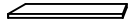
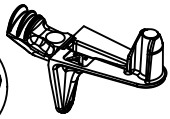
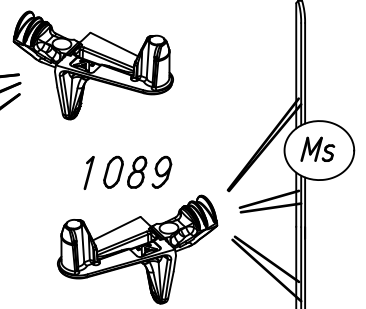
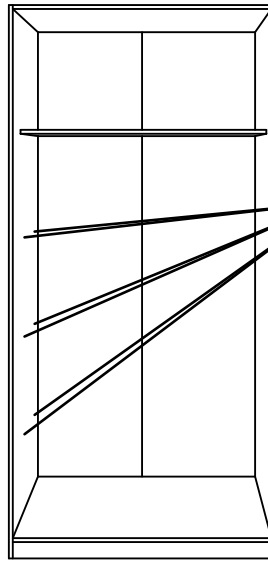

2

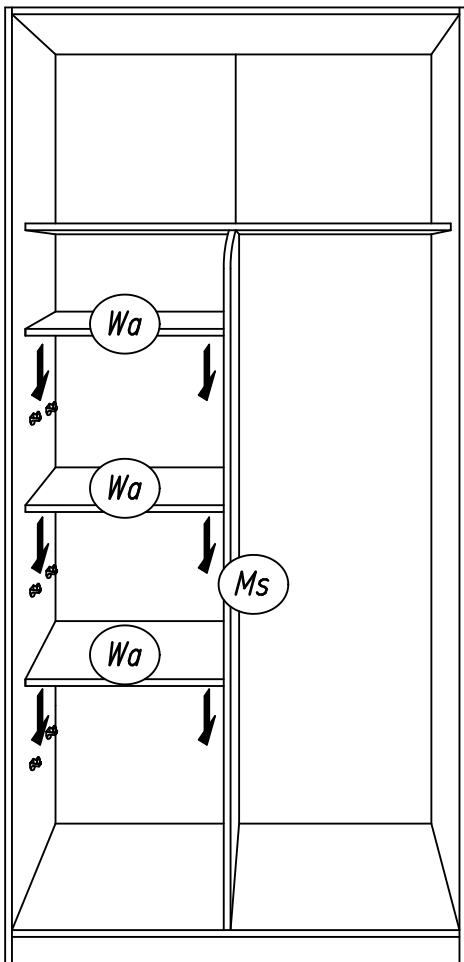
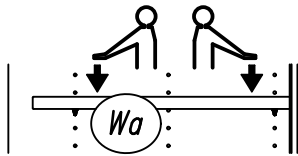

3

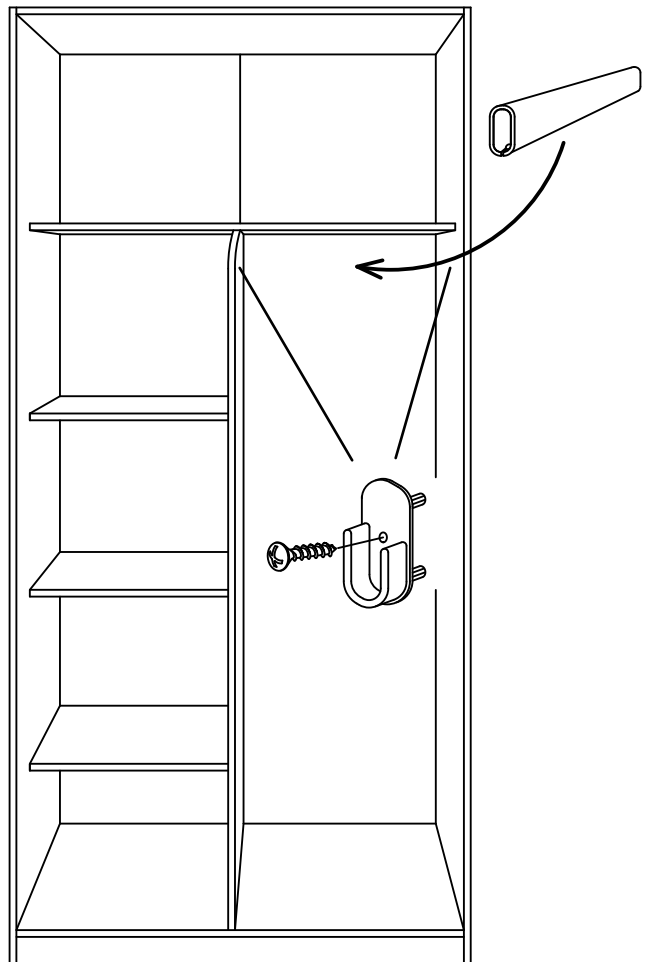

1.

M0850_02

rauch

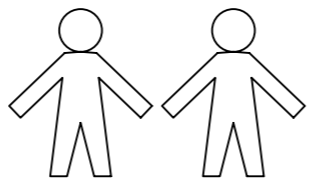
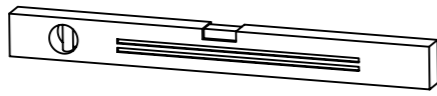
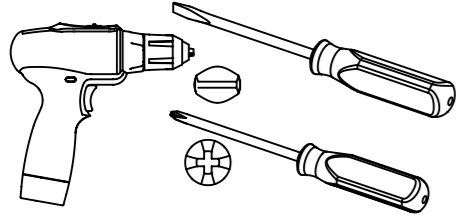

∅5mm

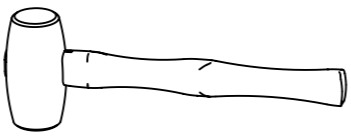
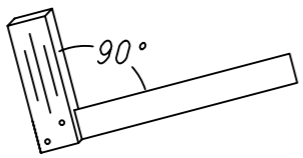
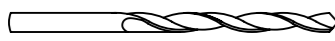

Typ I

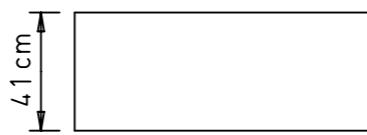
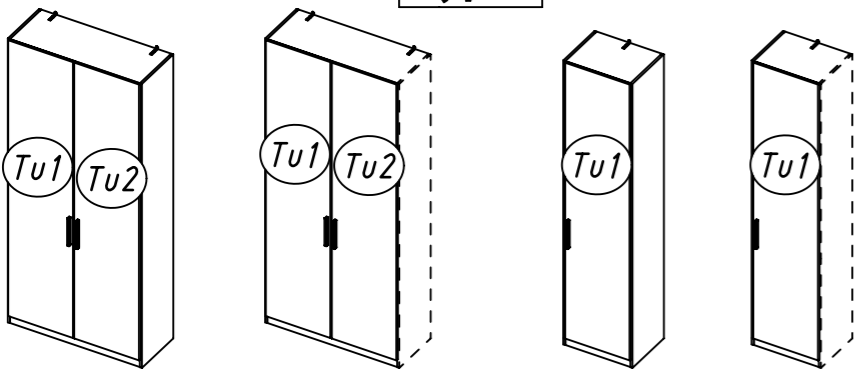

Typ II

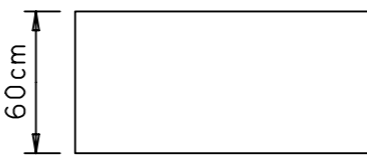
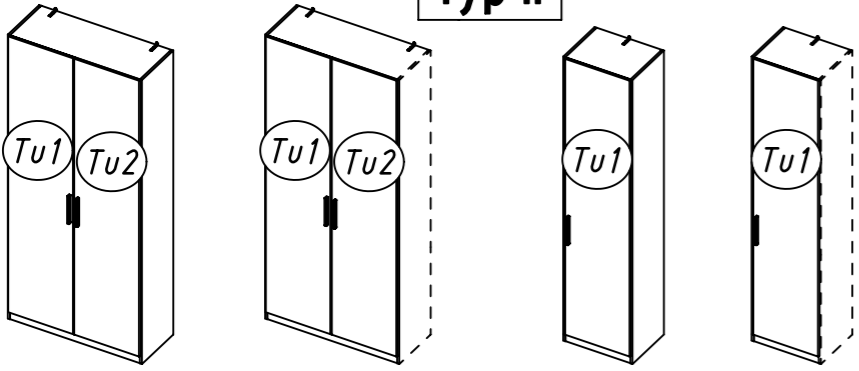

Typ III

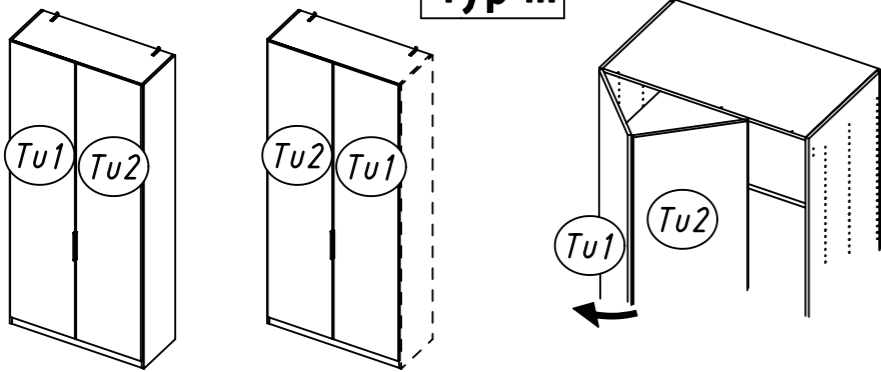

2.

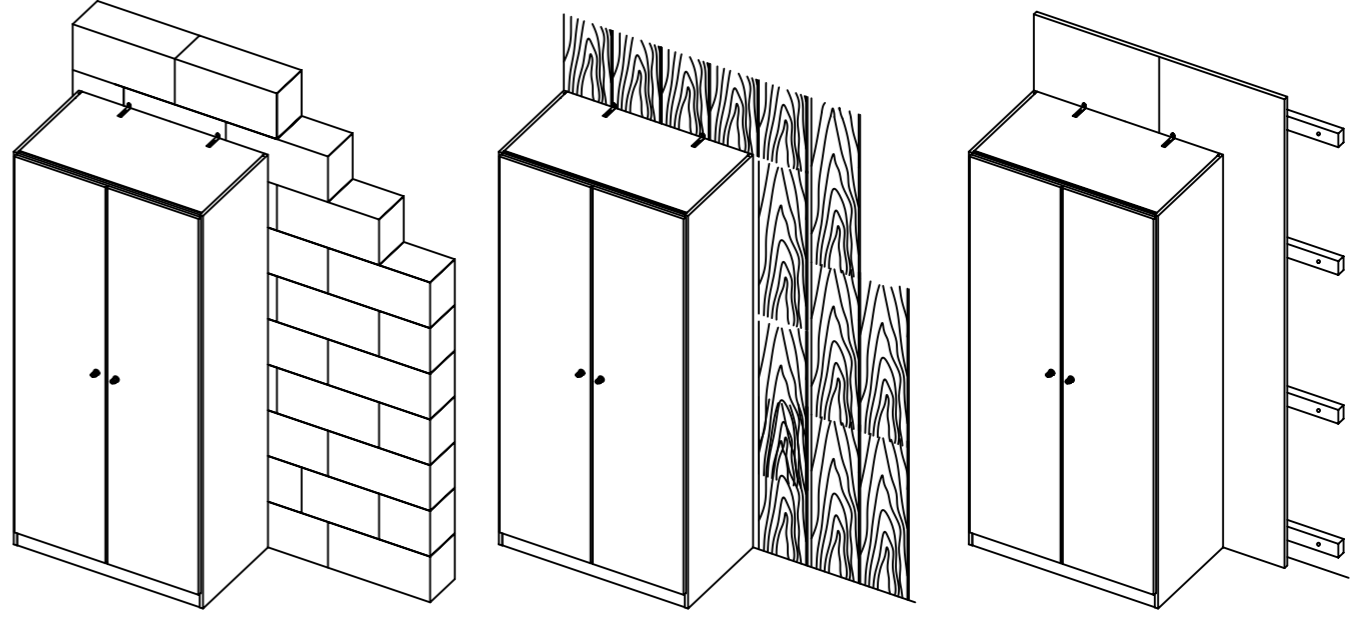
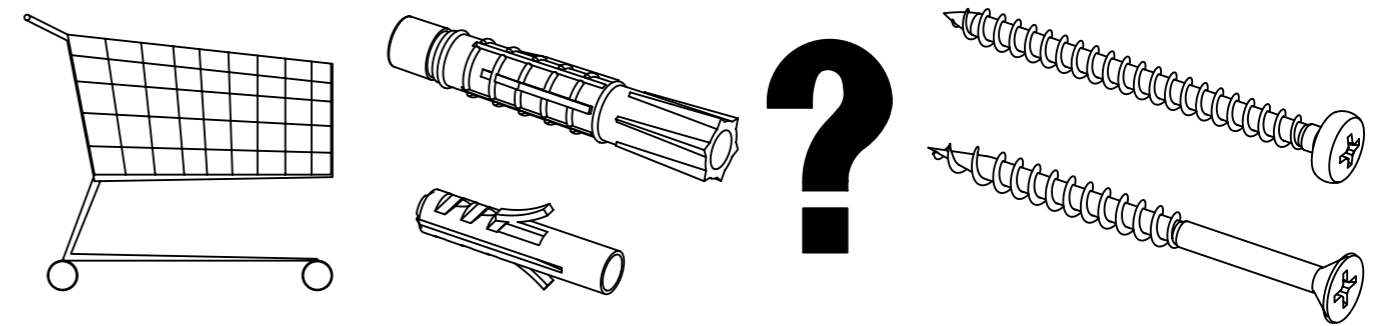
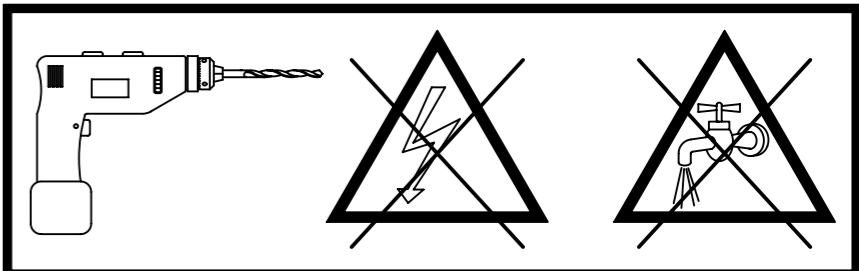
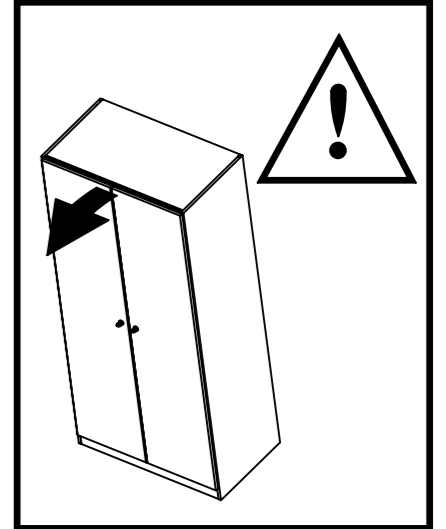
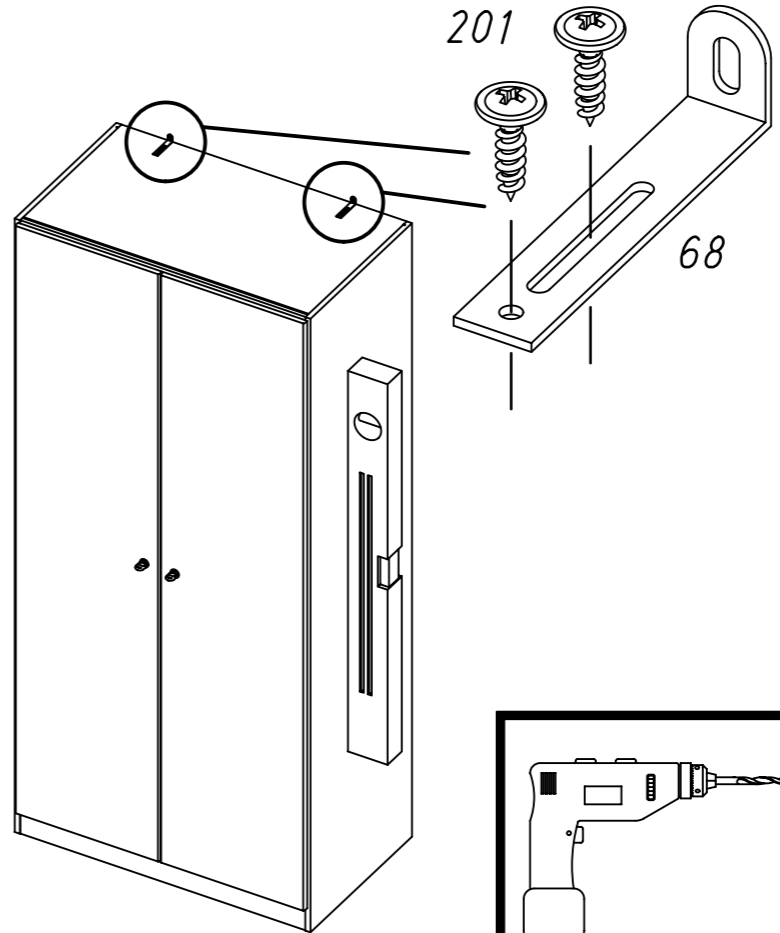

Typ I		Typ II		Typ III		
12 55x16x6	29	47	201 4x15	205 3,5x15	208 3,5x15	565
620	621 4x13	779 6,5x12	1085	1086	1089	Ks
Typ III						
109	110	118	119	179 6,3x13	580	
581	757 M4x30	676	677	812 118x35x11		
934	935	Fs1			Fs2	

Typ III

5.

1

8x 1085

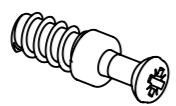

4x 1086

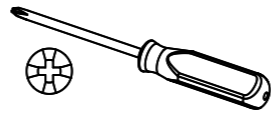
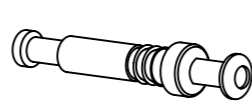

Typ I

Typ II

Typ III

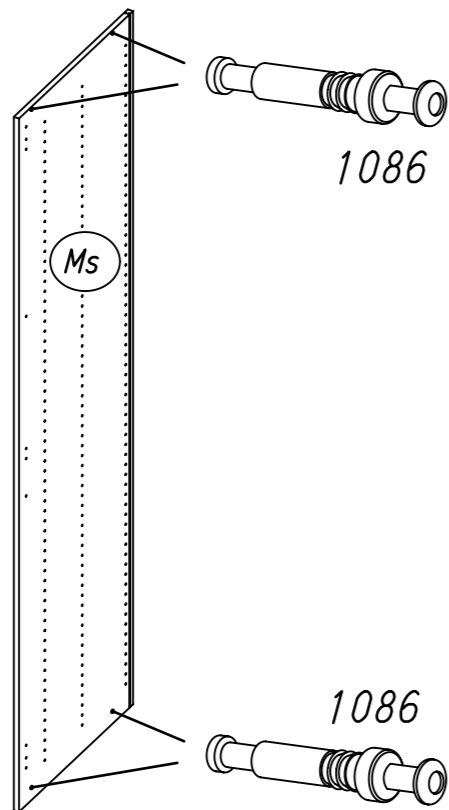
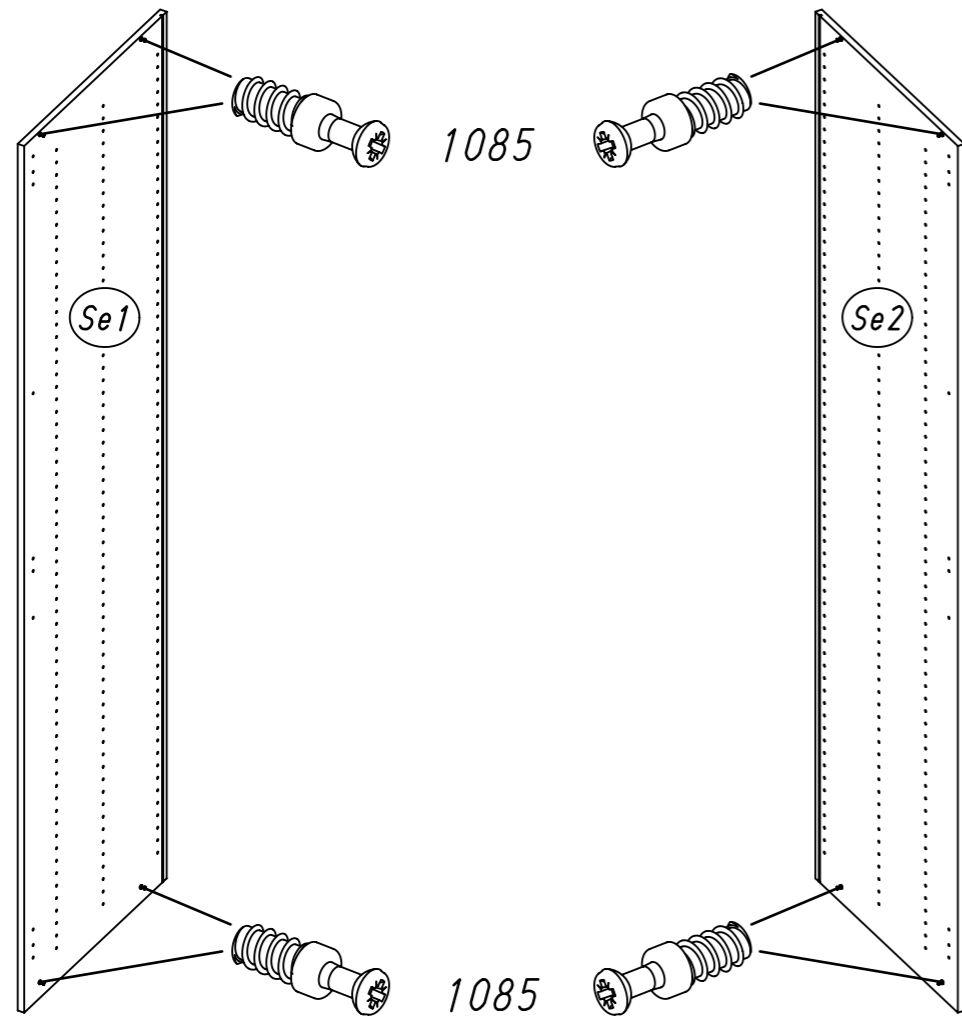

M0850

6.

2

6x 208

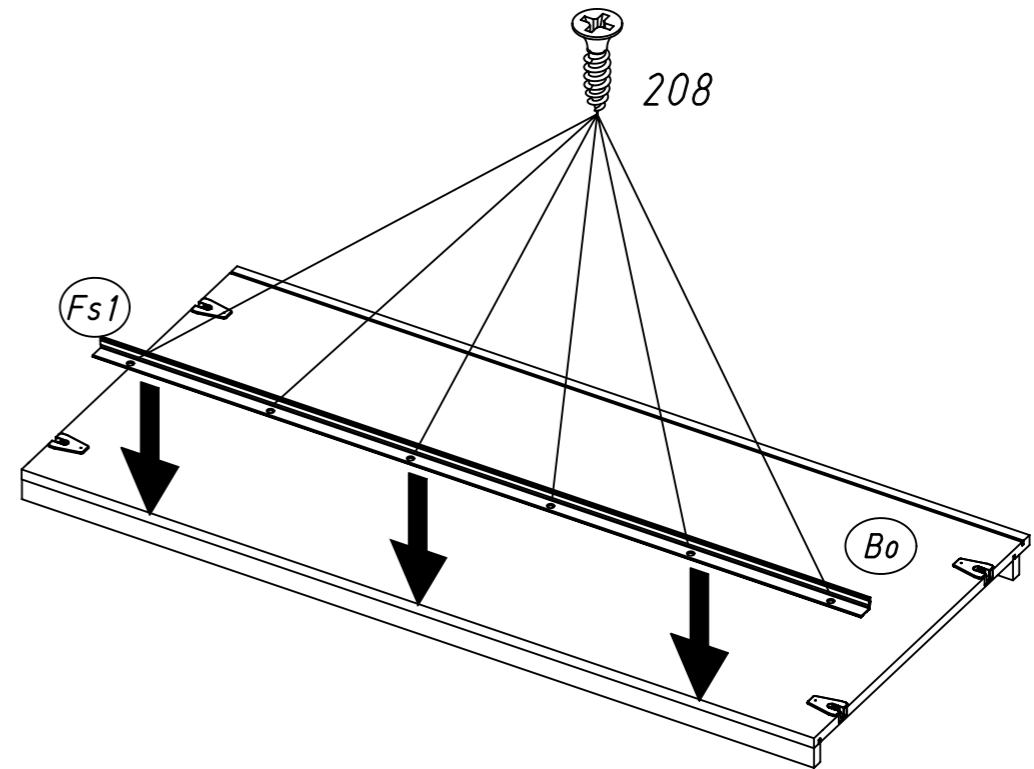
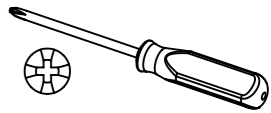
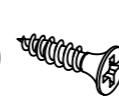

Typ III

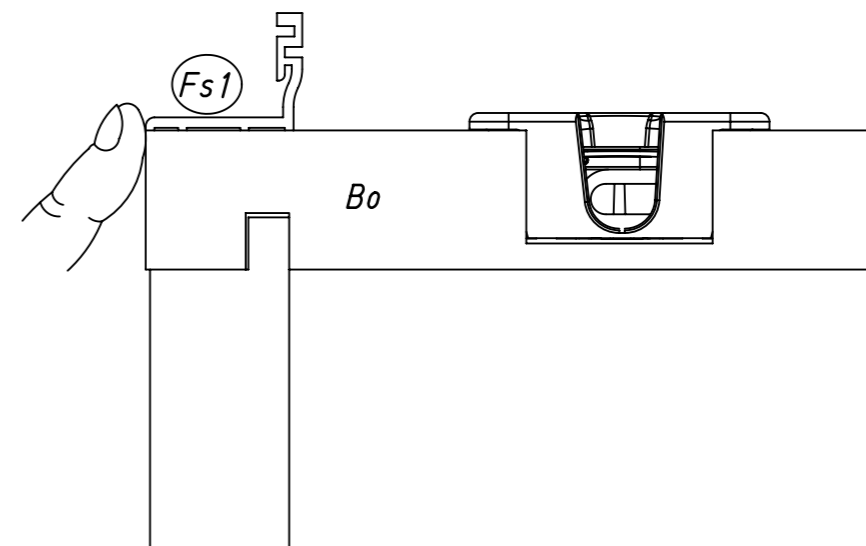

M0850

3

2x 47

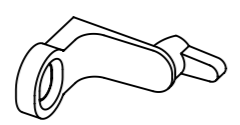

2x 779

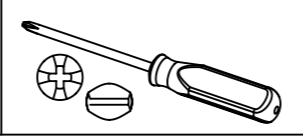

Typ I
Typ II
Typ III

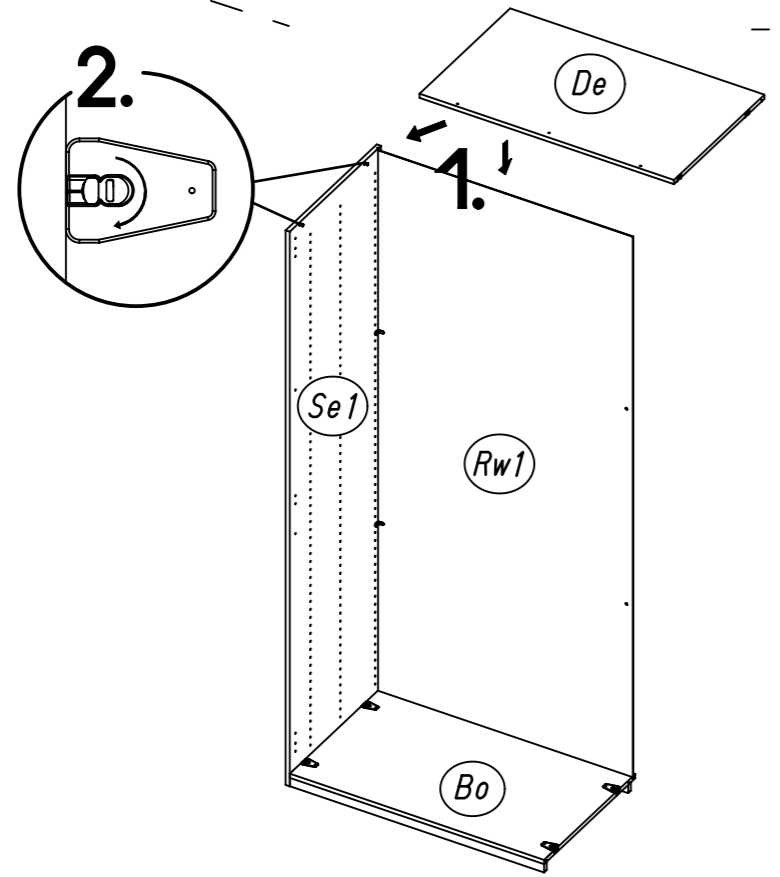
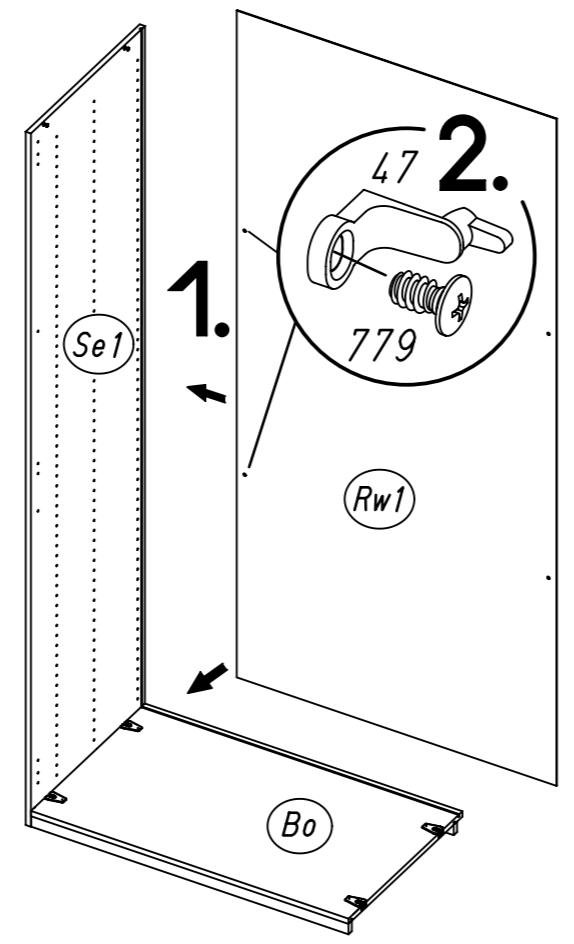
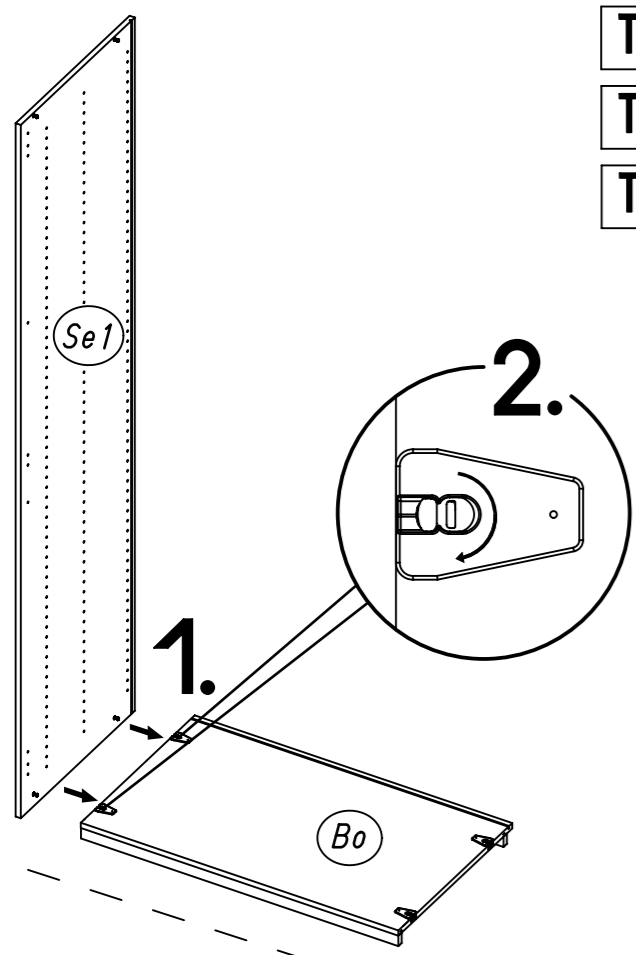

4

2x 47

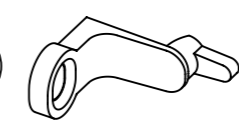

2x 779

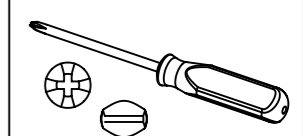
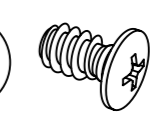

Typ I Typ II Typ III

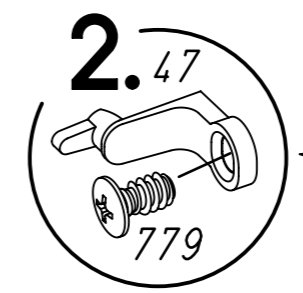
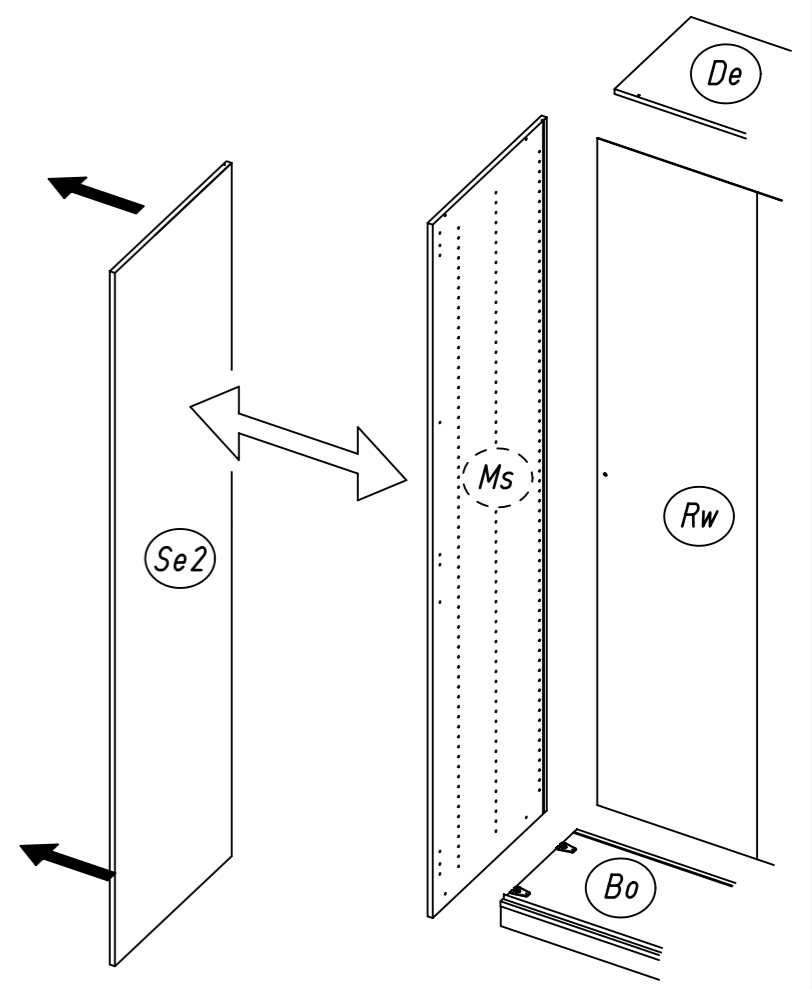
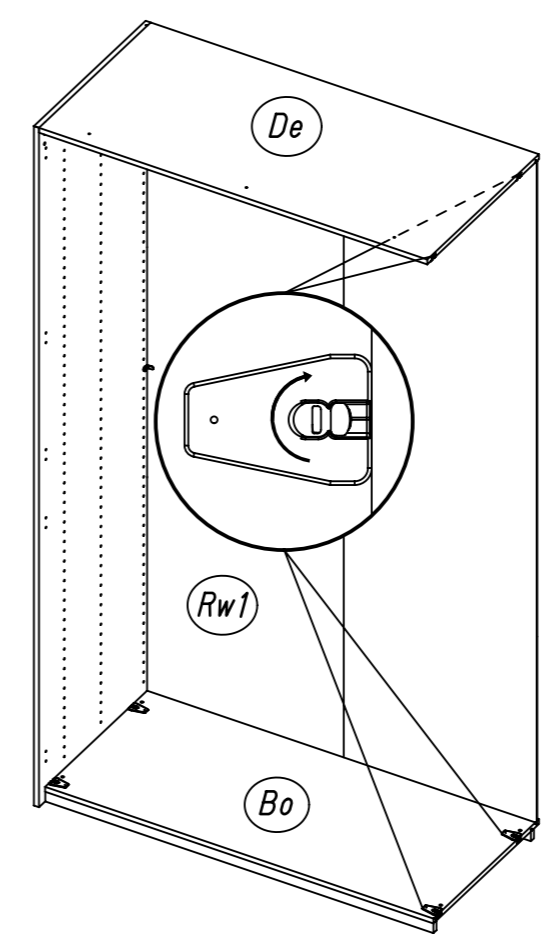

5

3x 179

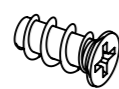

4x 1089

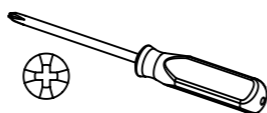
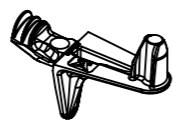

Typ III

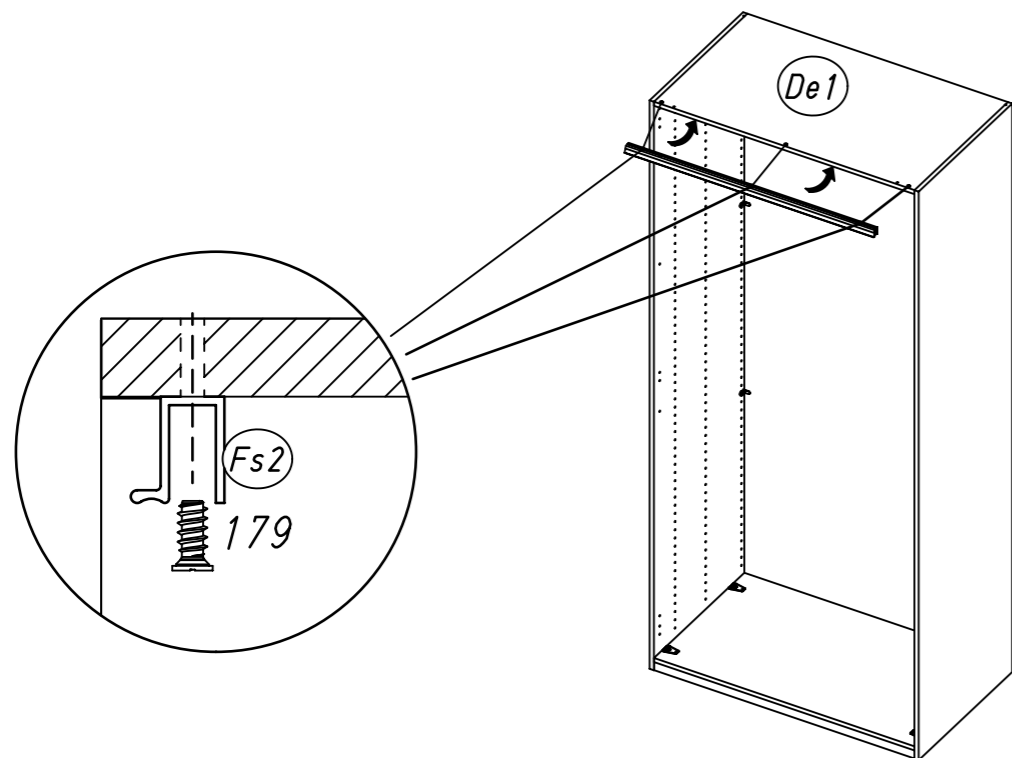

Typ I

Typ II

Typ III

Wa1

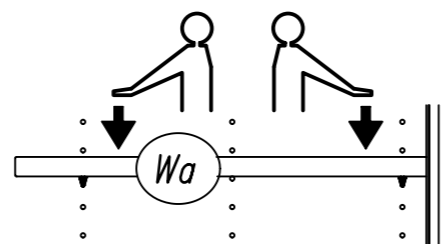
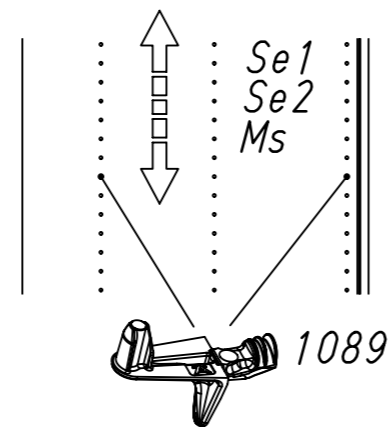
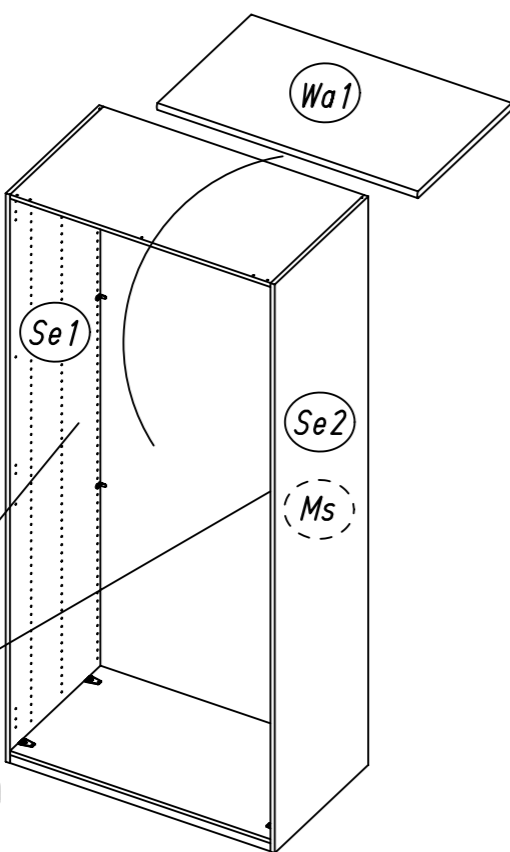

1089

6

1x 580



1x 581



1x 757

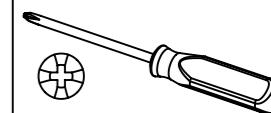
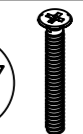

Typ III

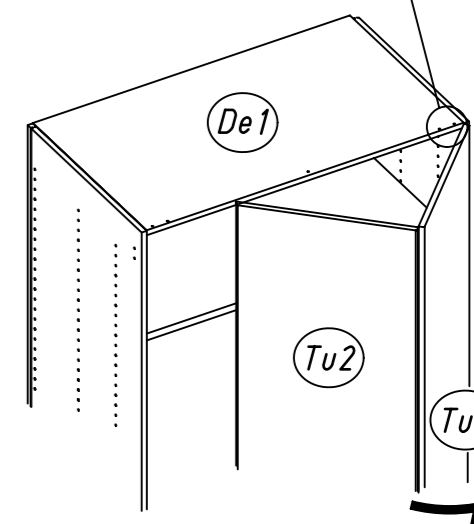
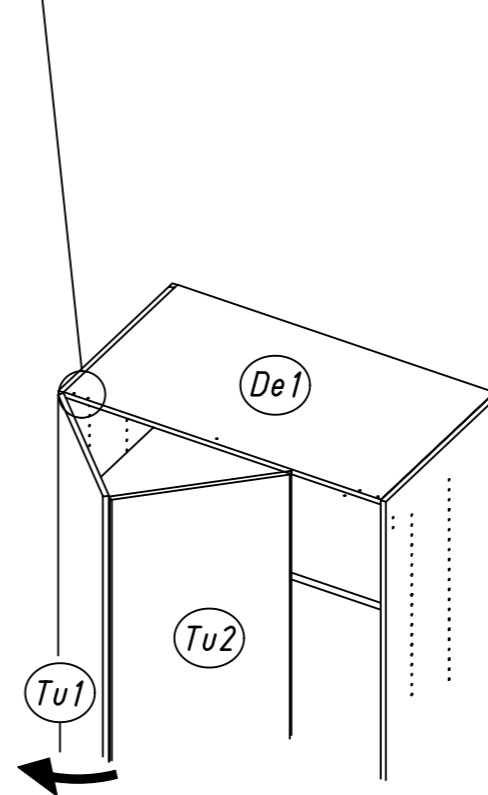
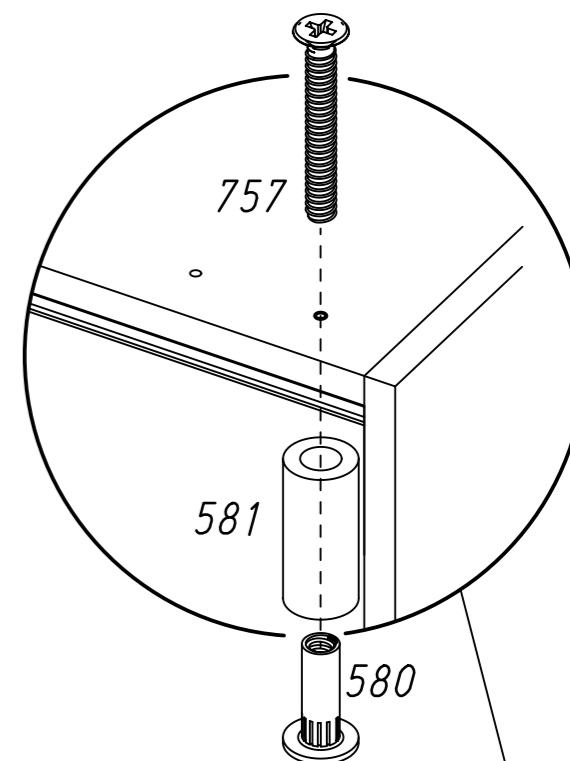
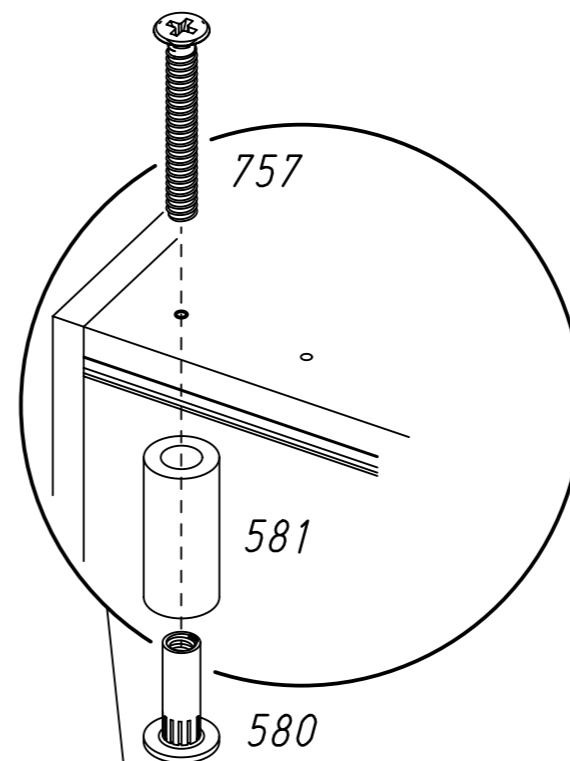

7

2x 205



2x 29



6x 565

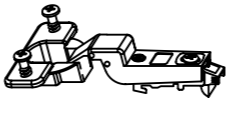

Typ II
Typ III

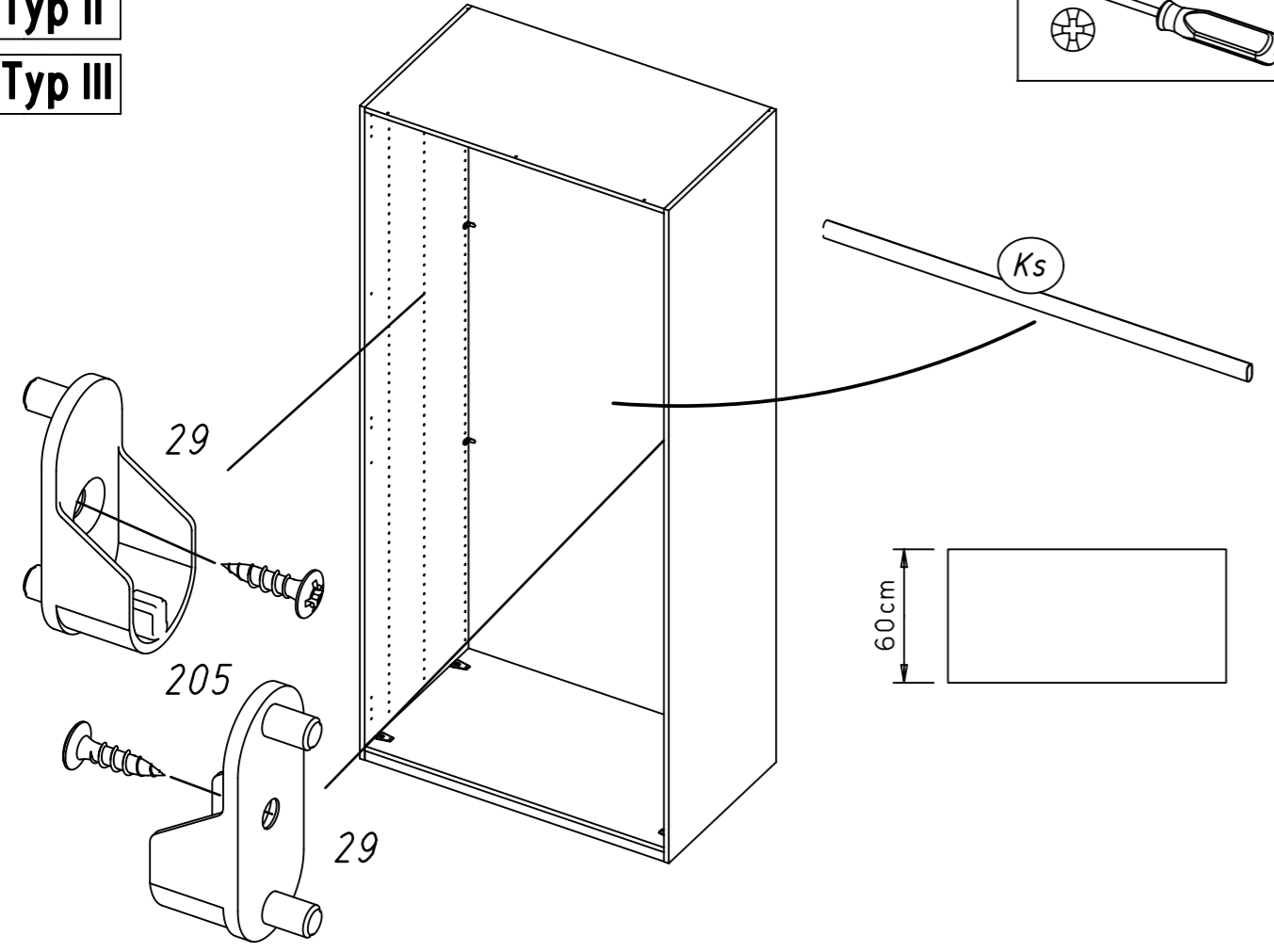
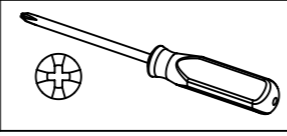

Typ I
Typ II

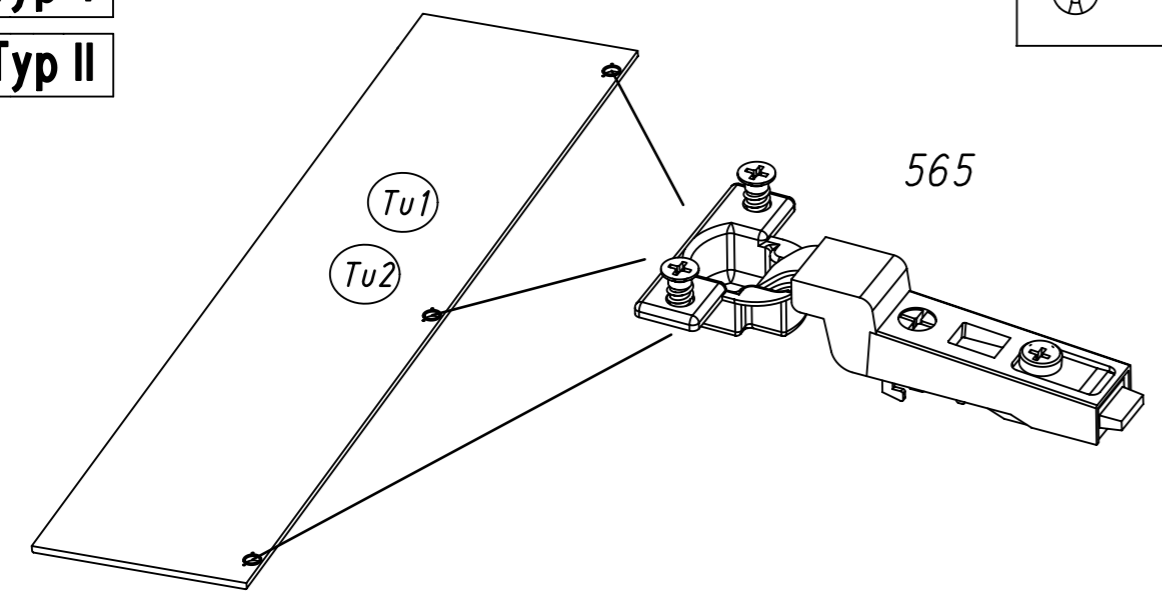
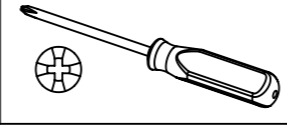

8

3x 620

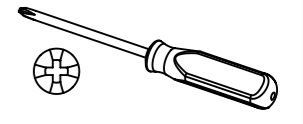
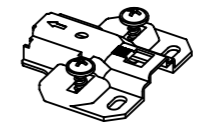

Typ III

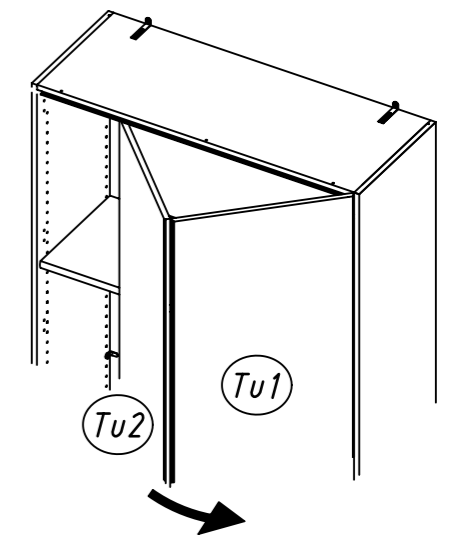
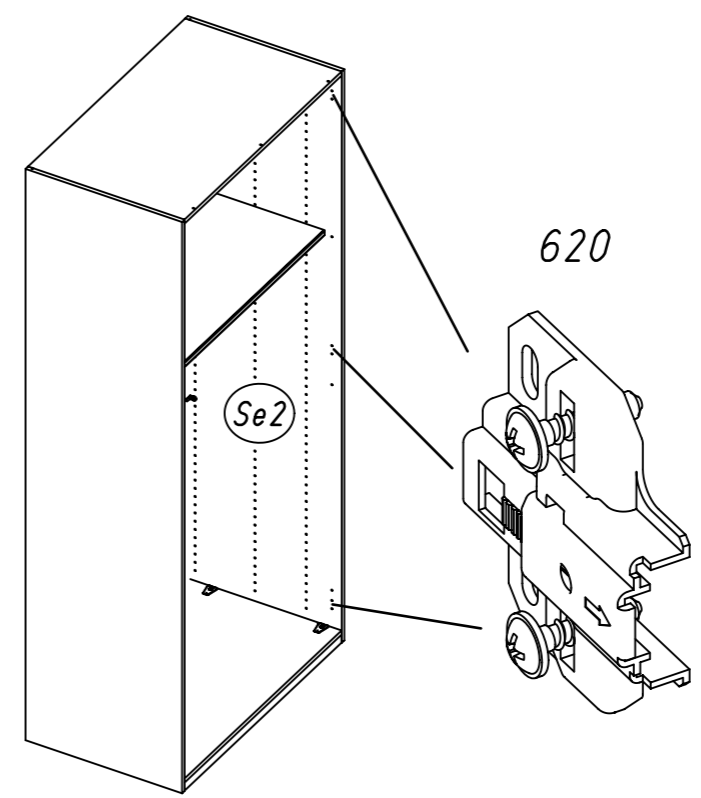
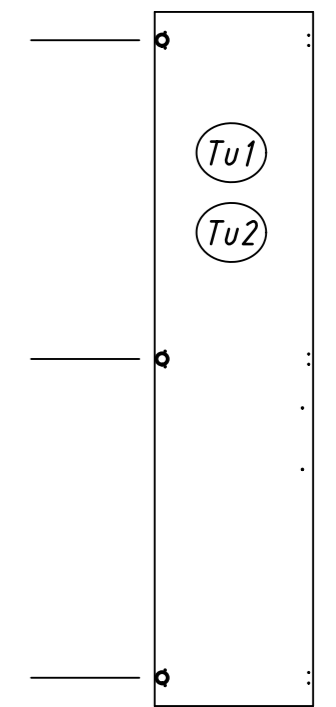
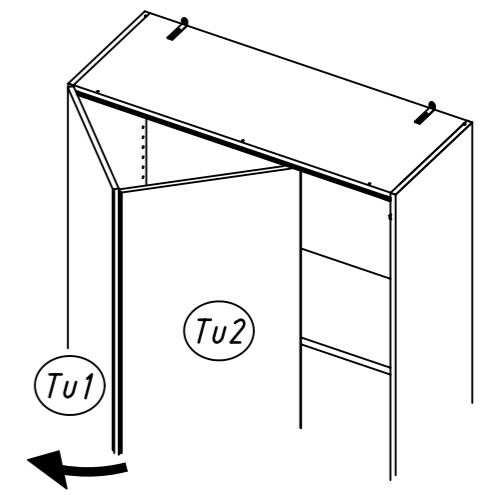
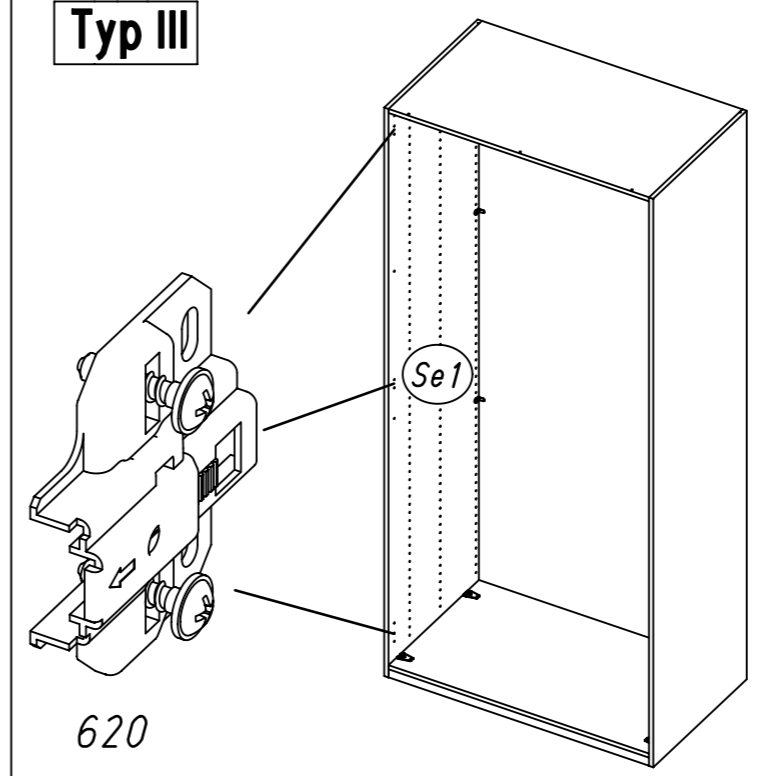

9

620

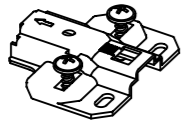

- Typ I
- Typ II
- Typ III

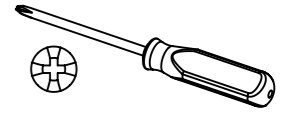
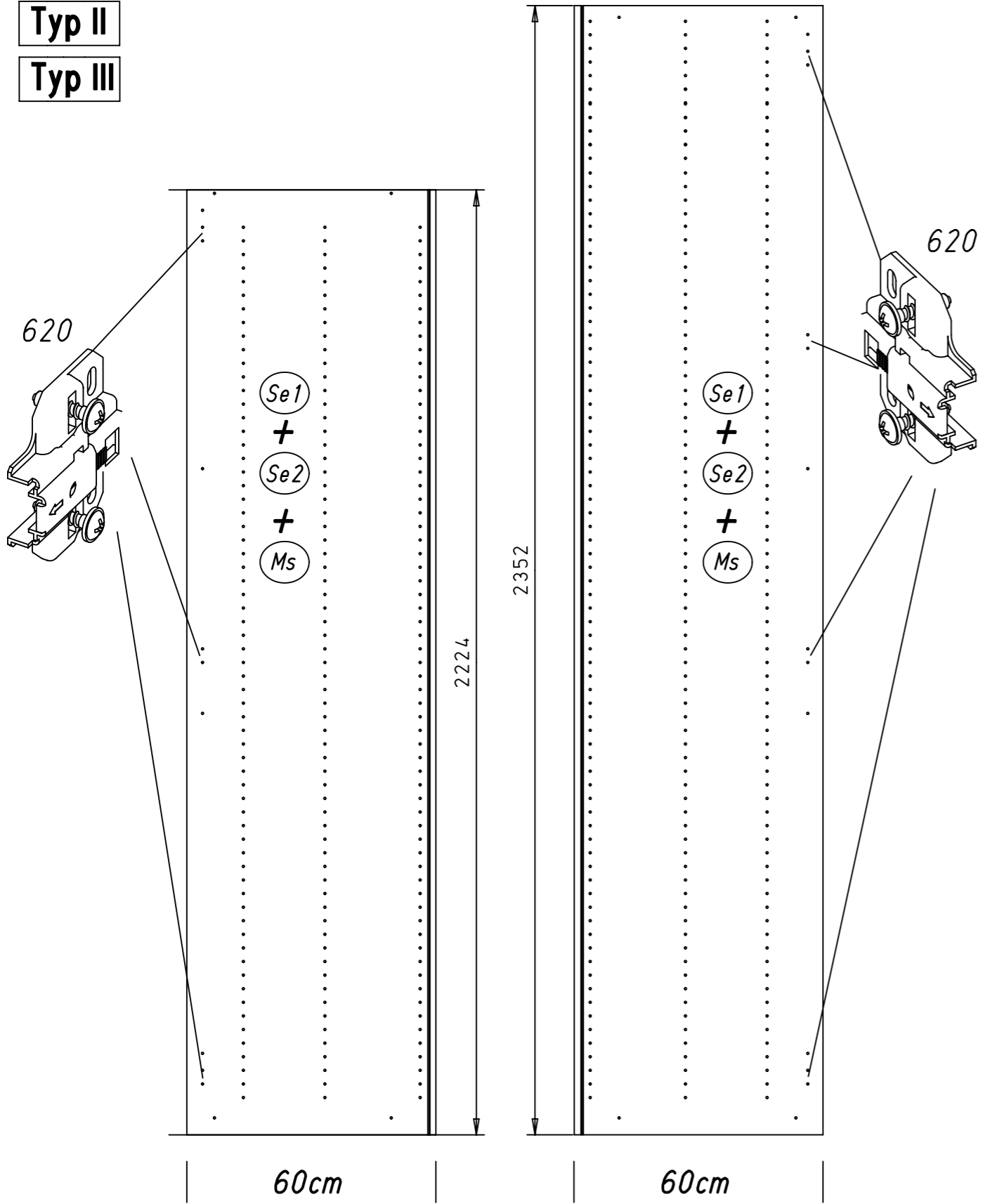

- Typ I
- Typ II
- Typ III

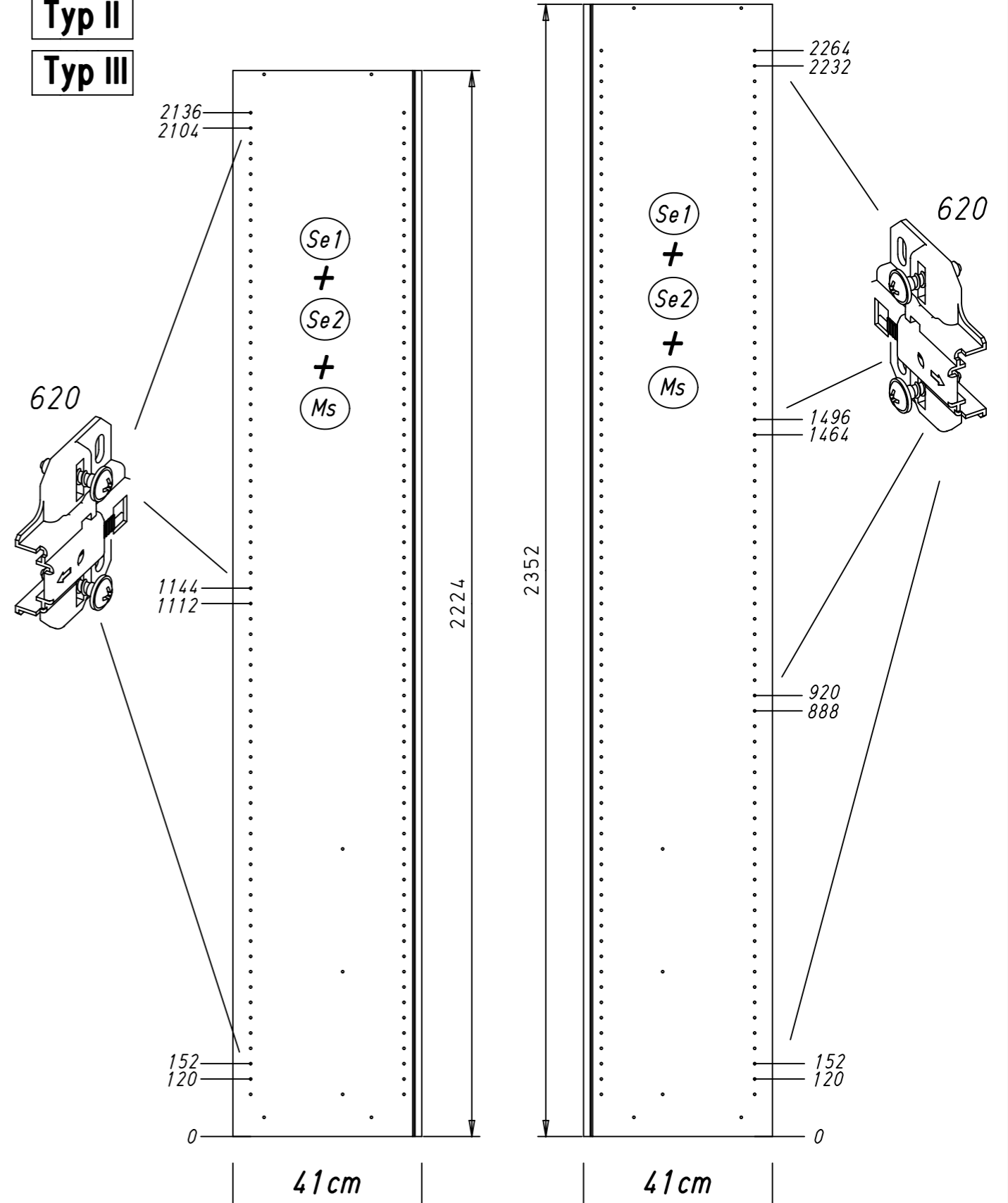

- 10 **3x** 565  **3x** 110 
- 6x** 179 

Typ III

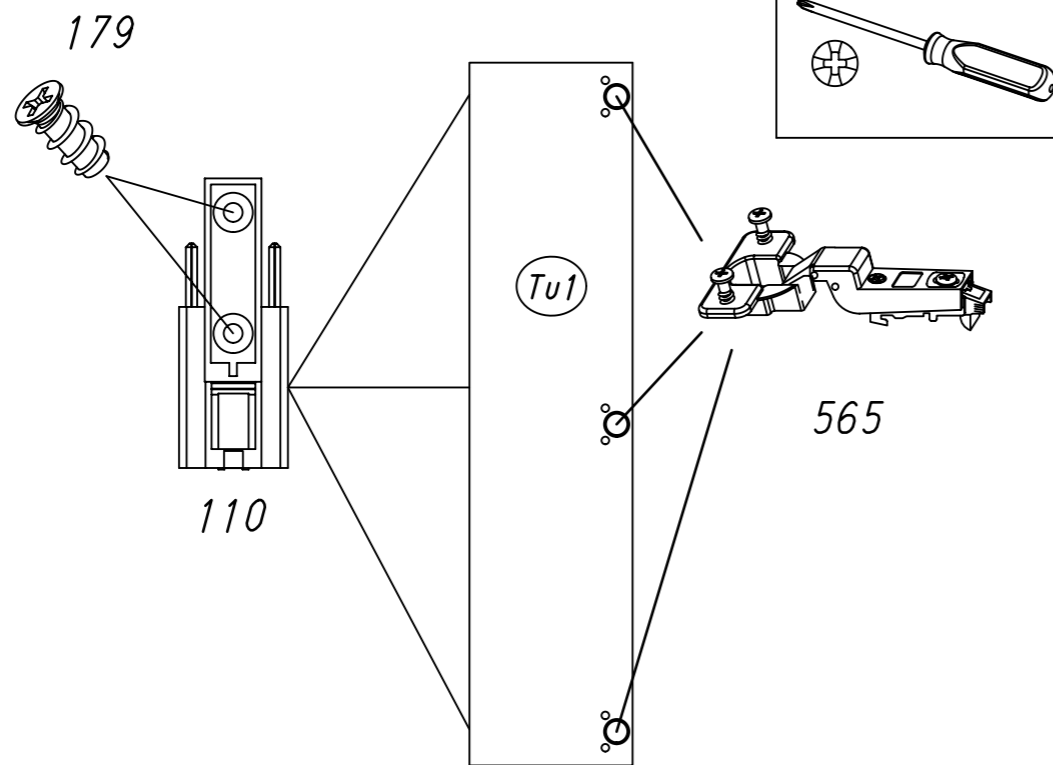

Typ III

- 11 **8x** 179  **3x** 109 

Typ III

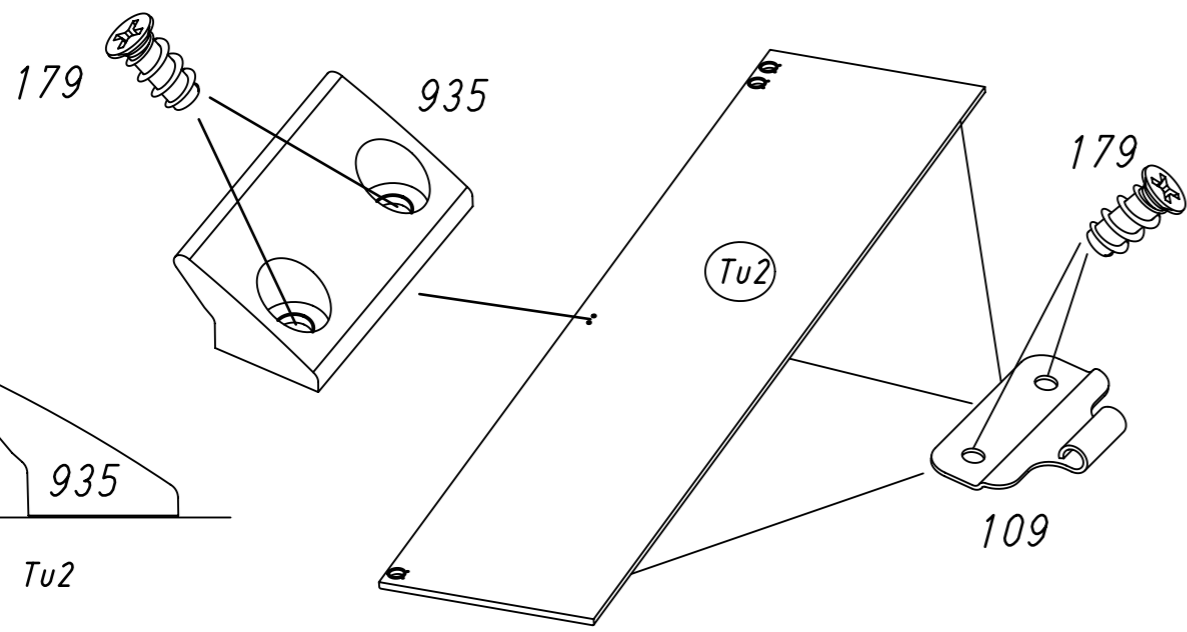

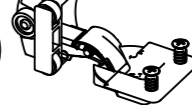
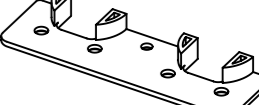
- 12 **1x** 205  **1x** $\begin{matrix} 118 \\ 119 \end{matrix}$  **1x** 812 

Typ III

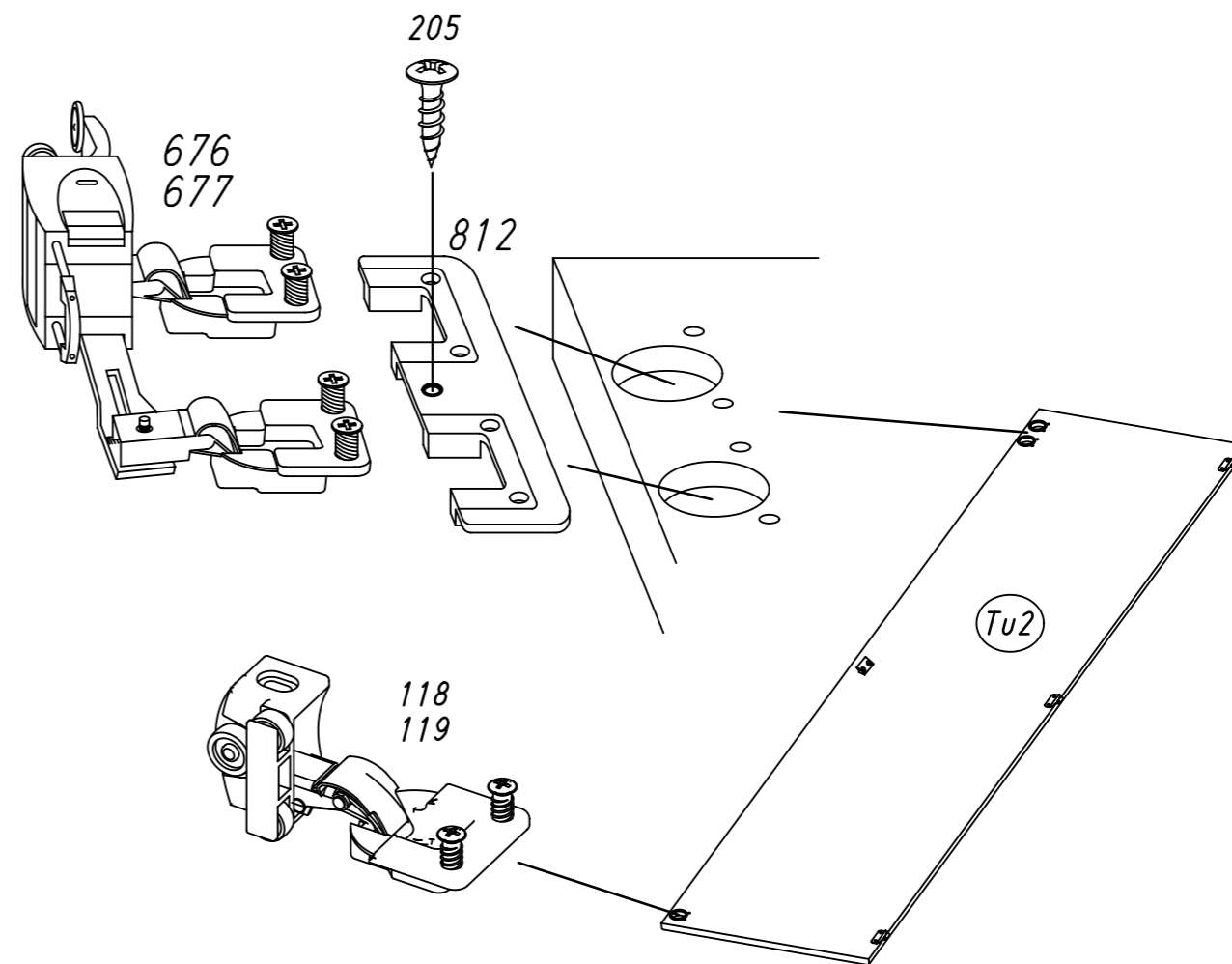

13

Typ I Typ II

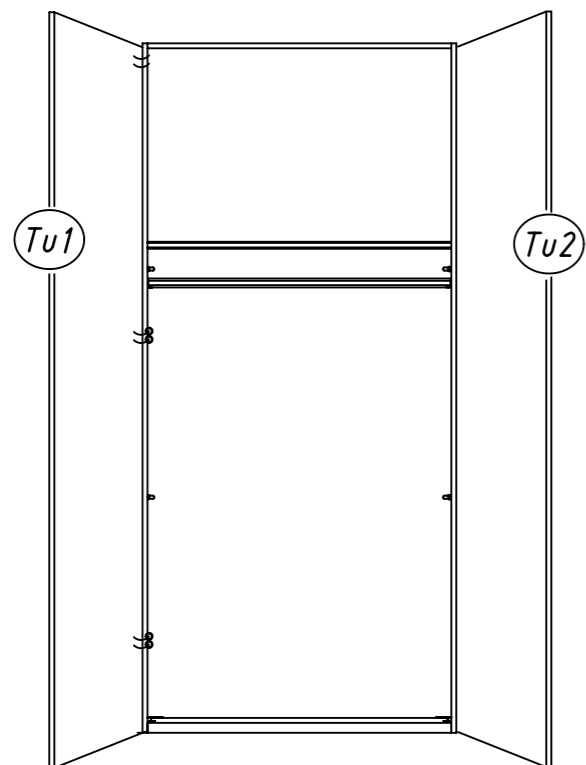
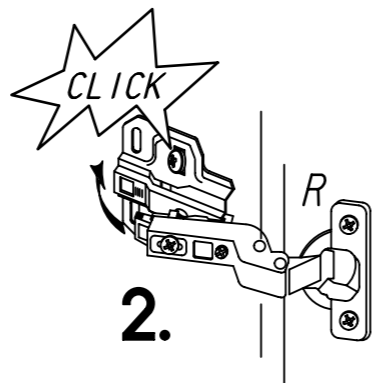
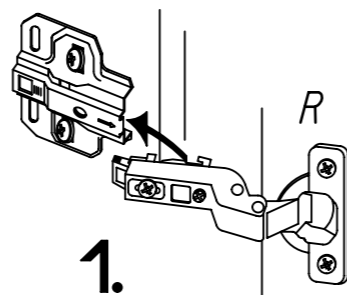
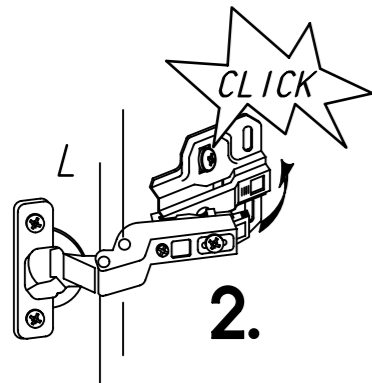
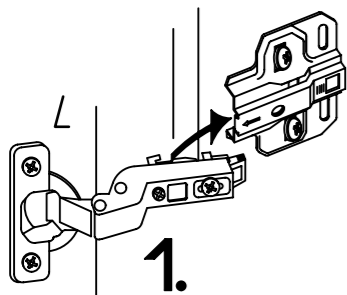

14

Typ III

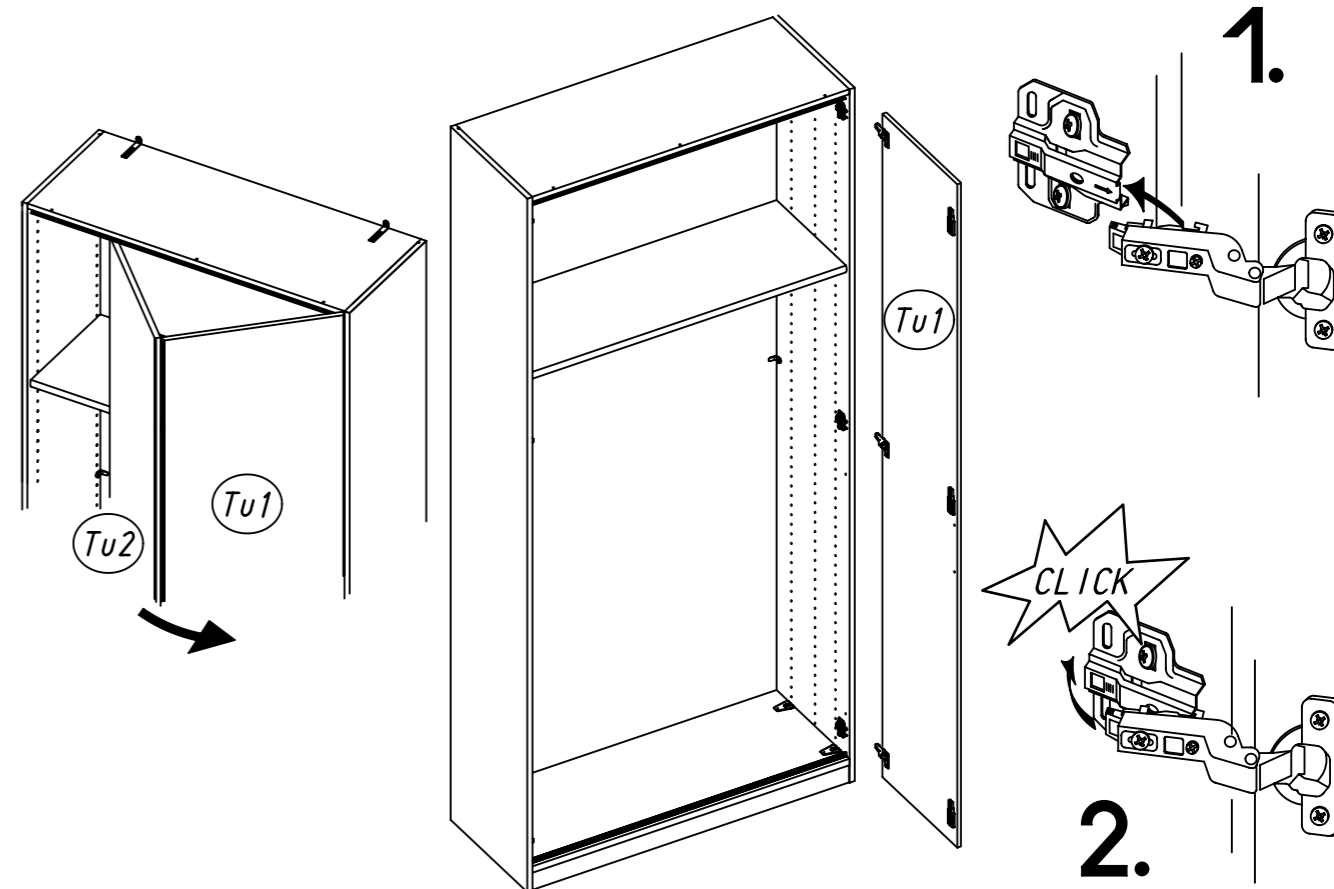
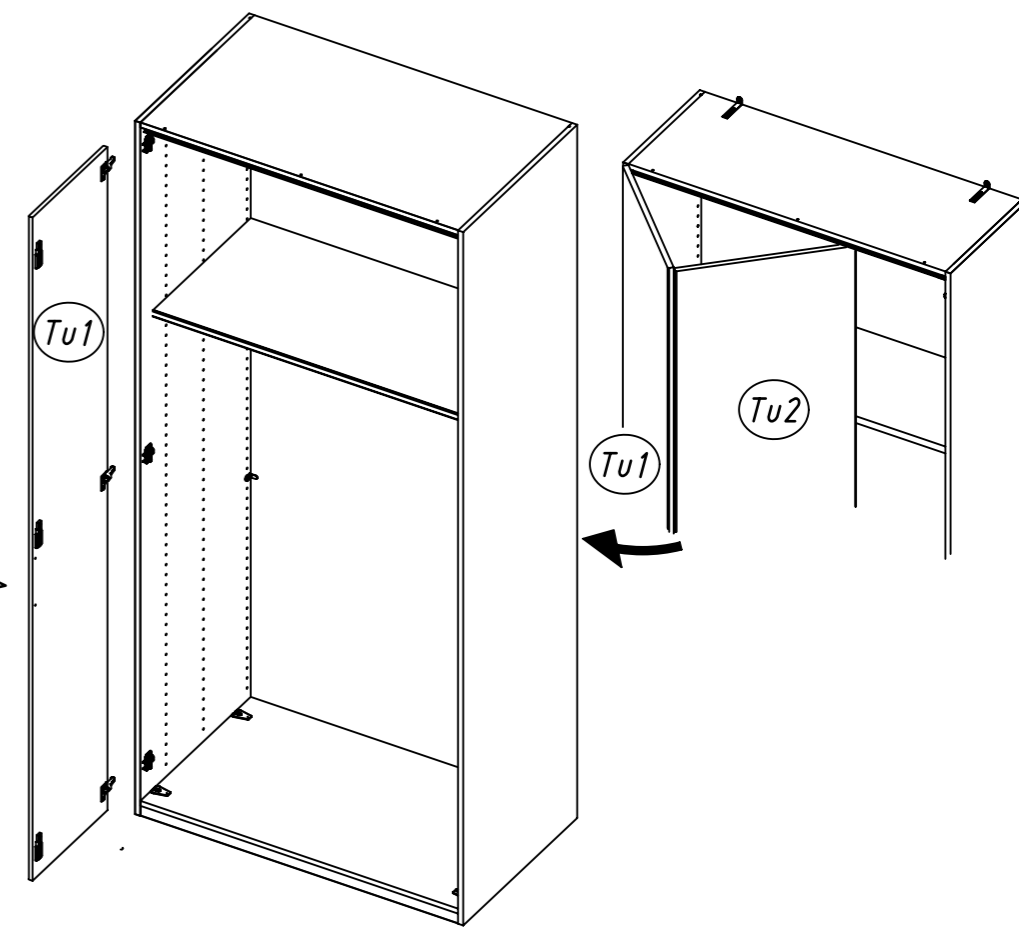
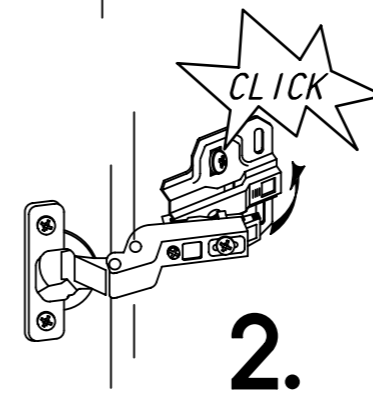
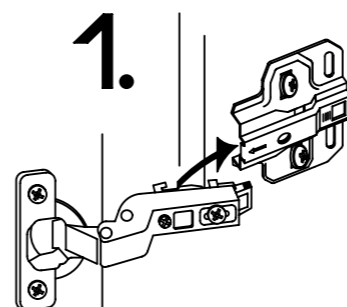

15

Typ III

1.

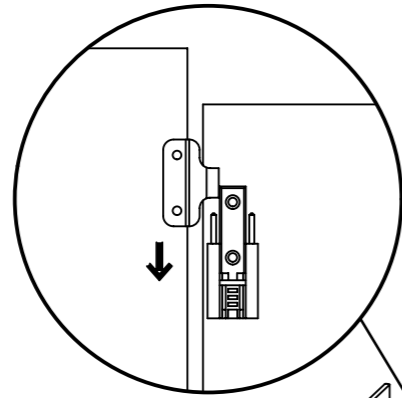
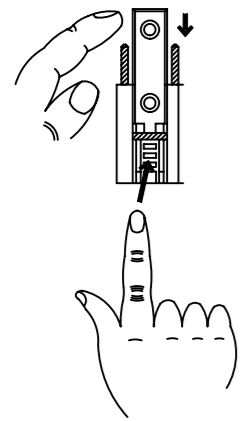

2.

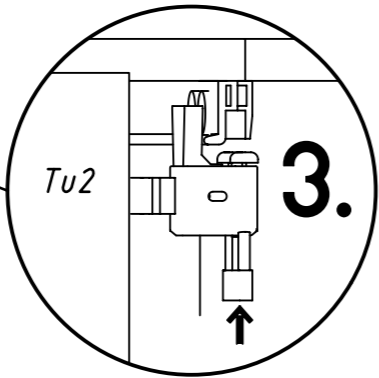
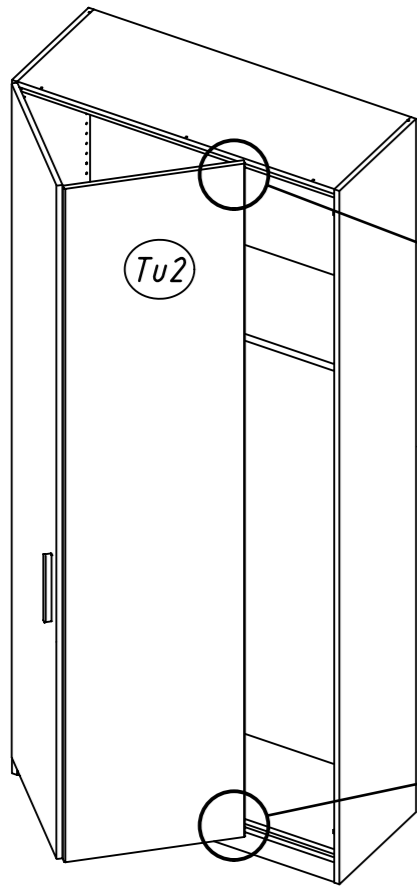
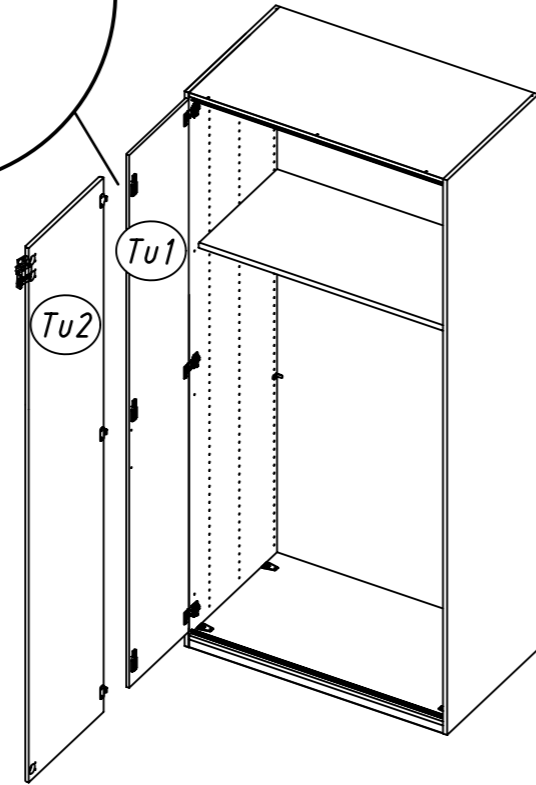

3.

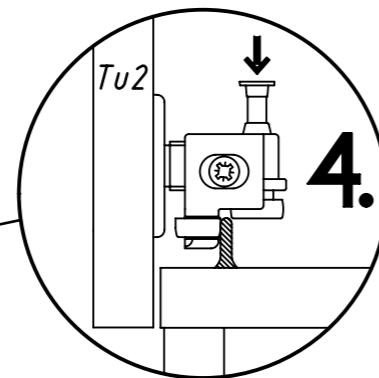

4.

16

2x 201

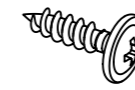

1x 934

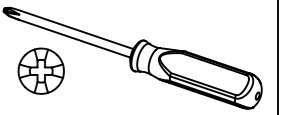
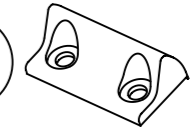

Typ III

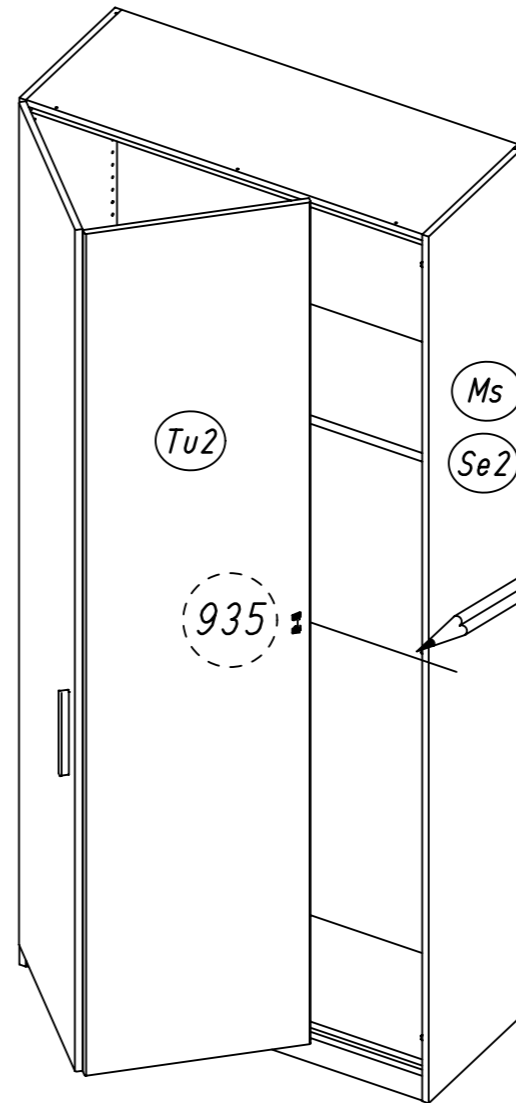

Ms
Se2

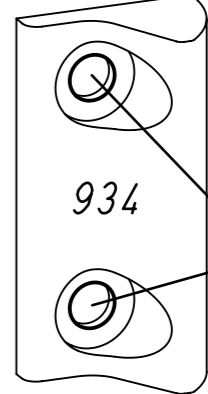

201

934

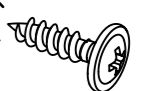

201

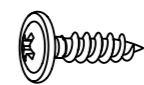

Ms
Se2

934

Ms
Se2

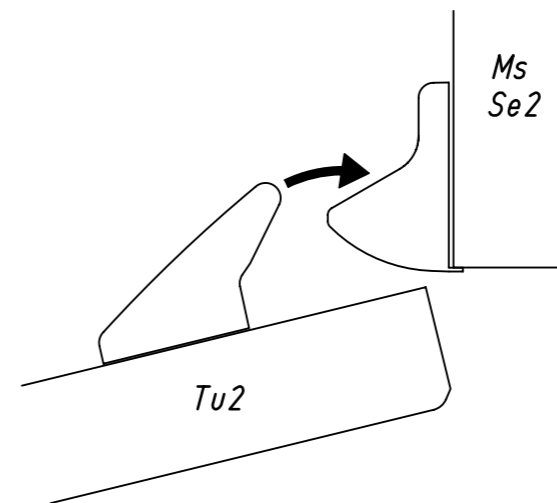

Tu2

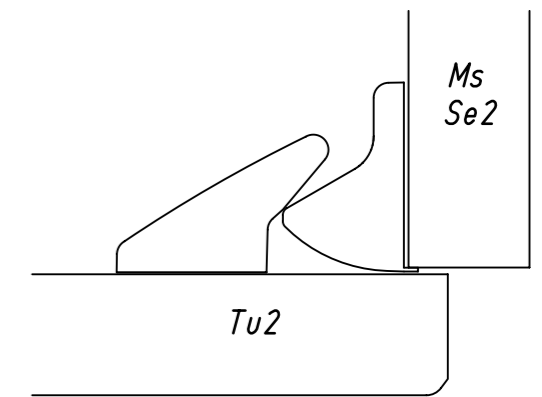

Tu2

17

2 x 12

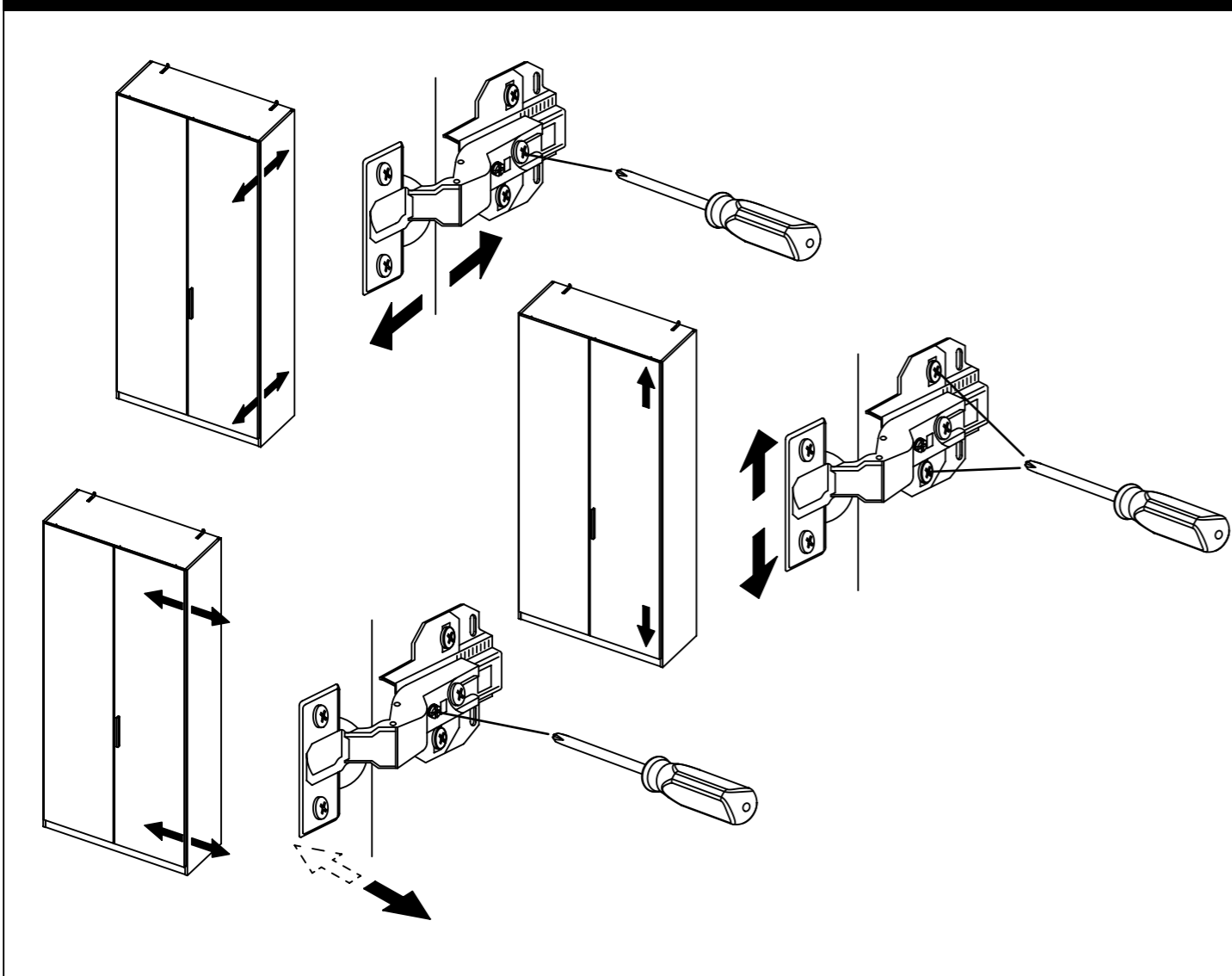
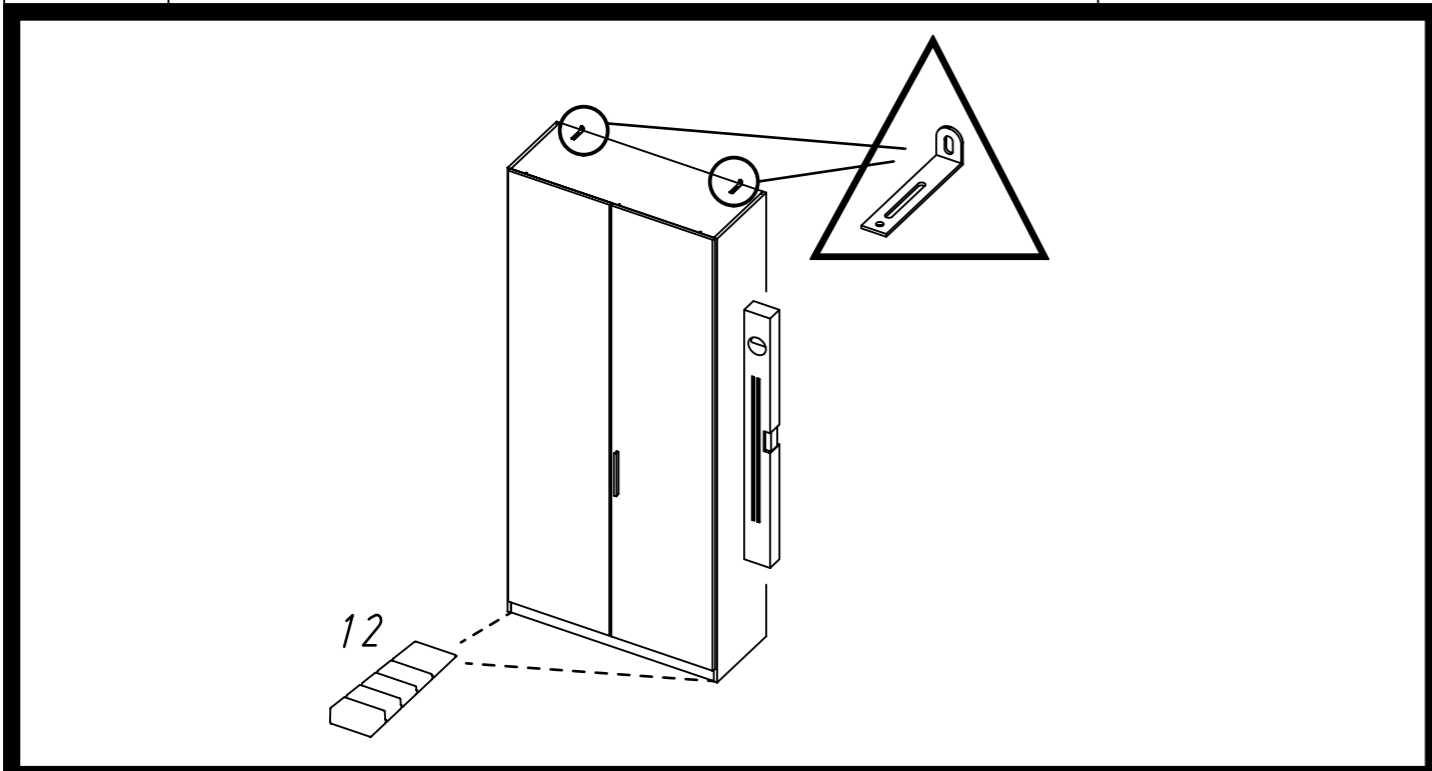
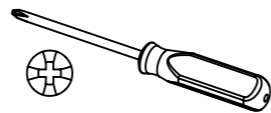
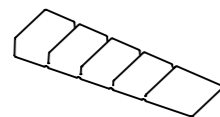

18

12 x 621

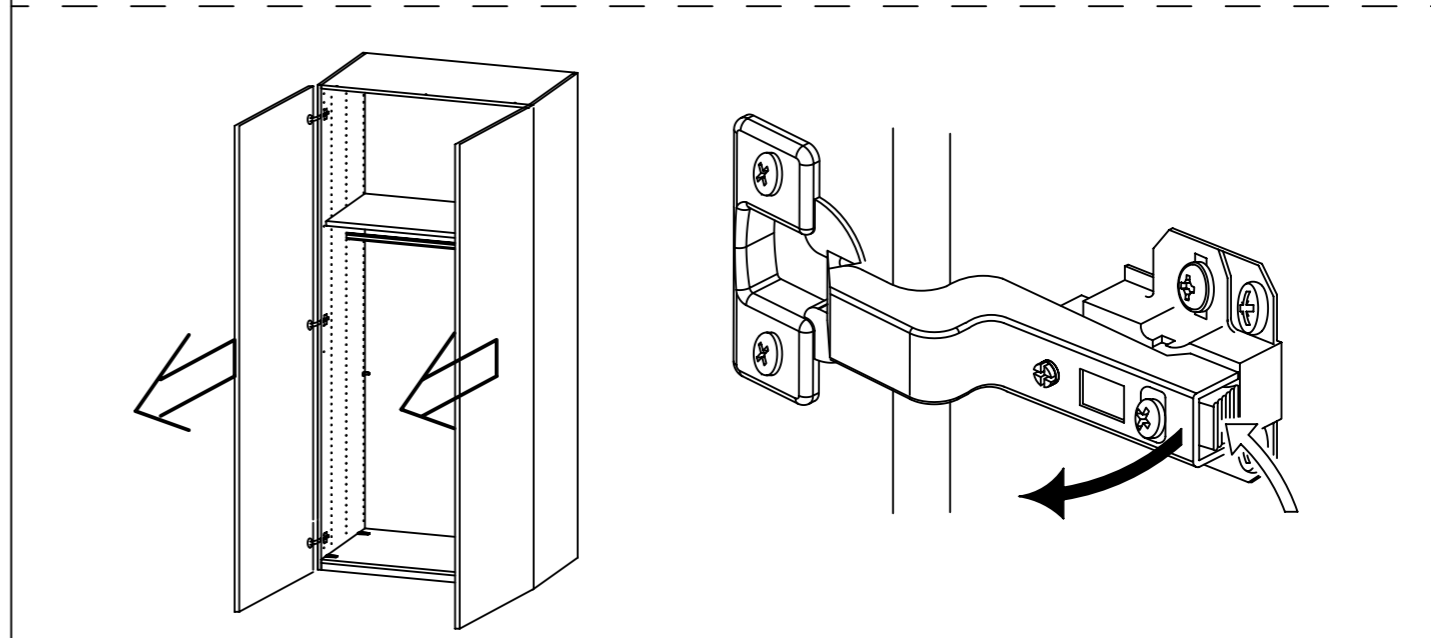
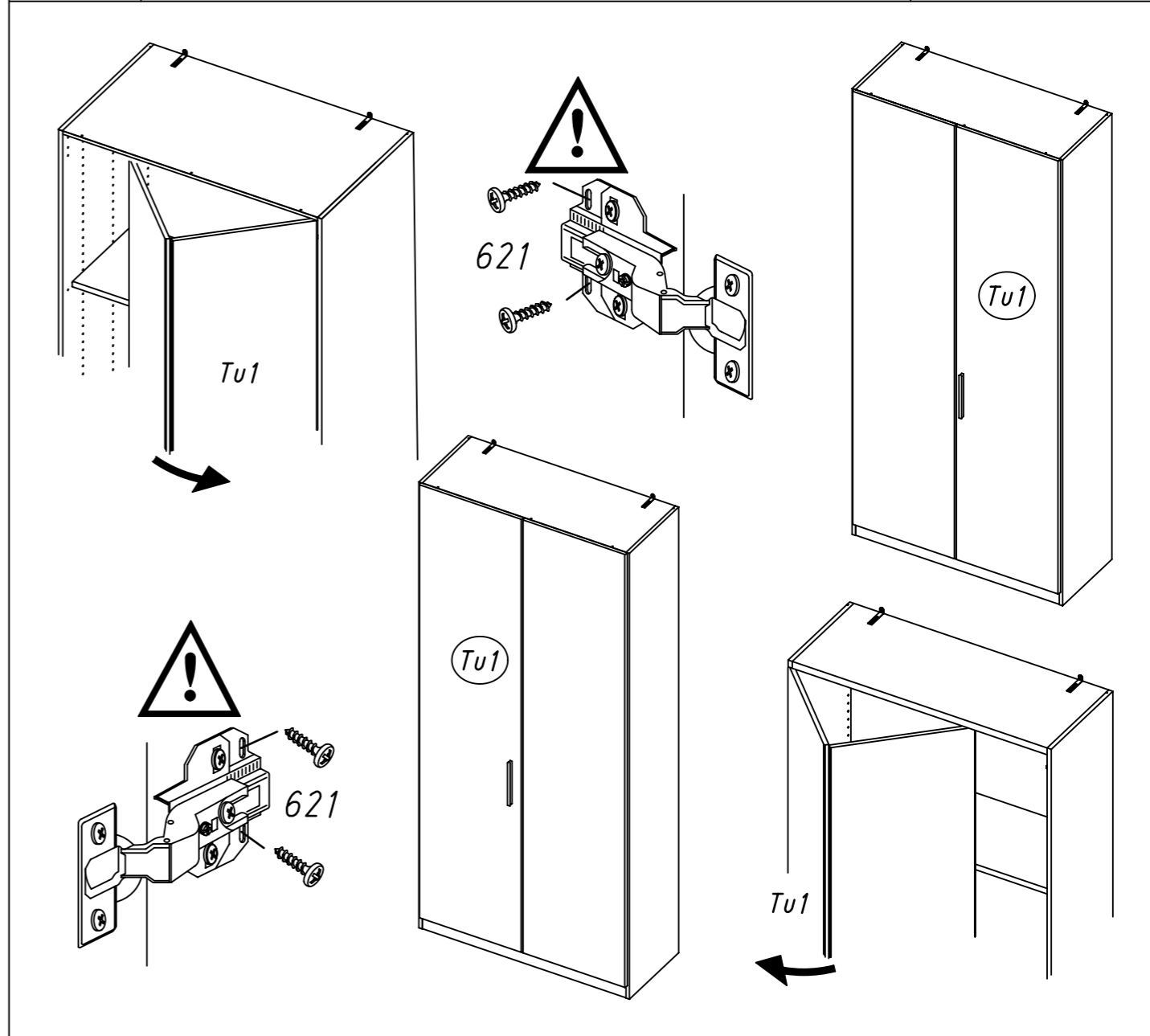
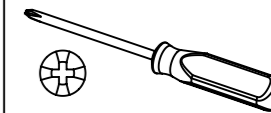

19

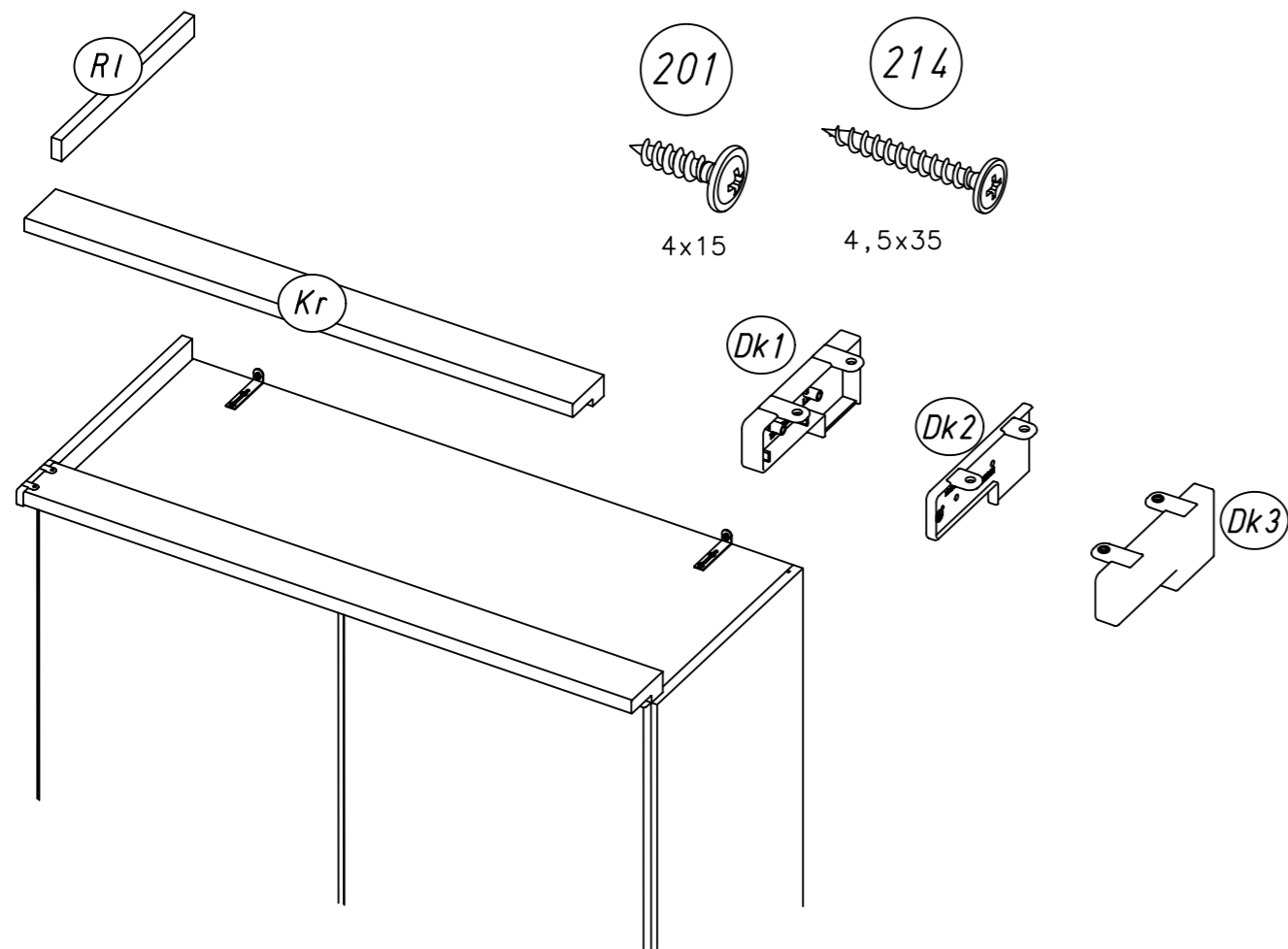
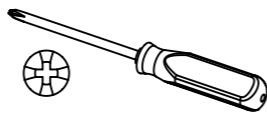

20

4 x 201

3 x 214

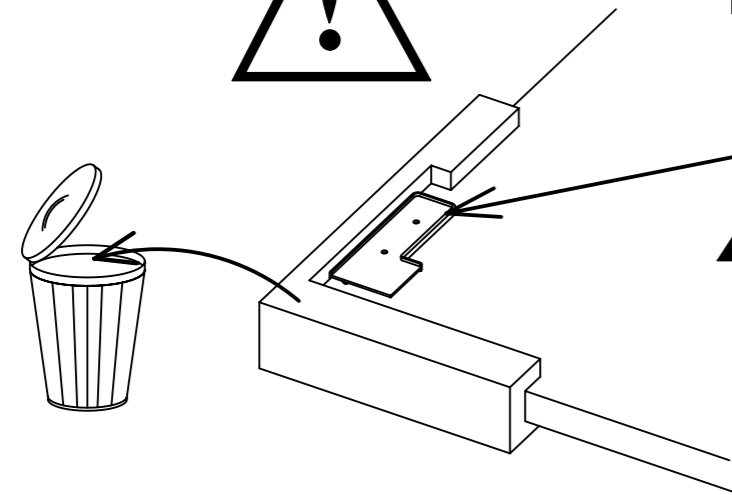
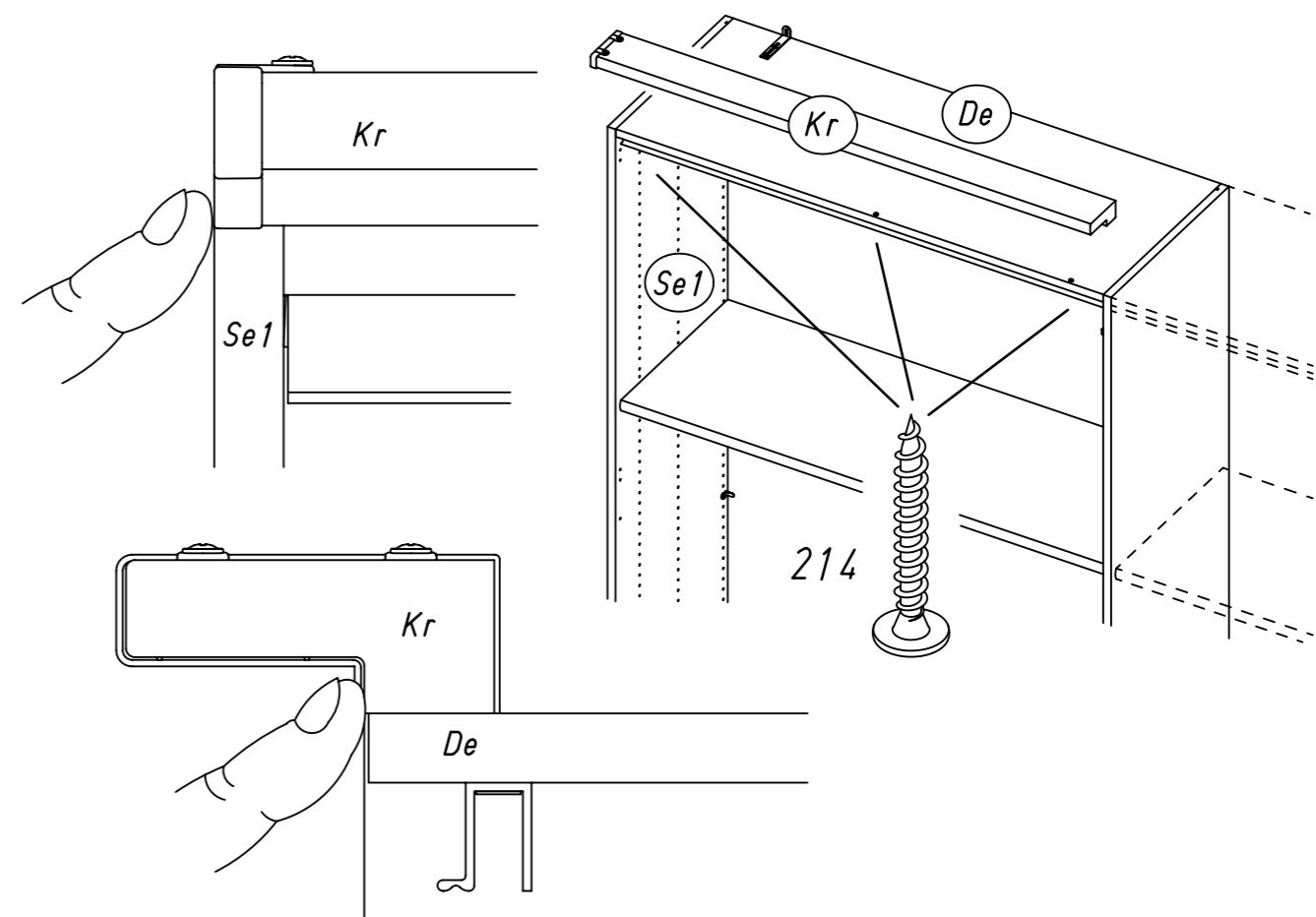
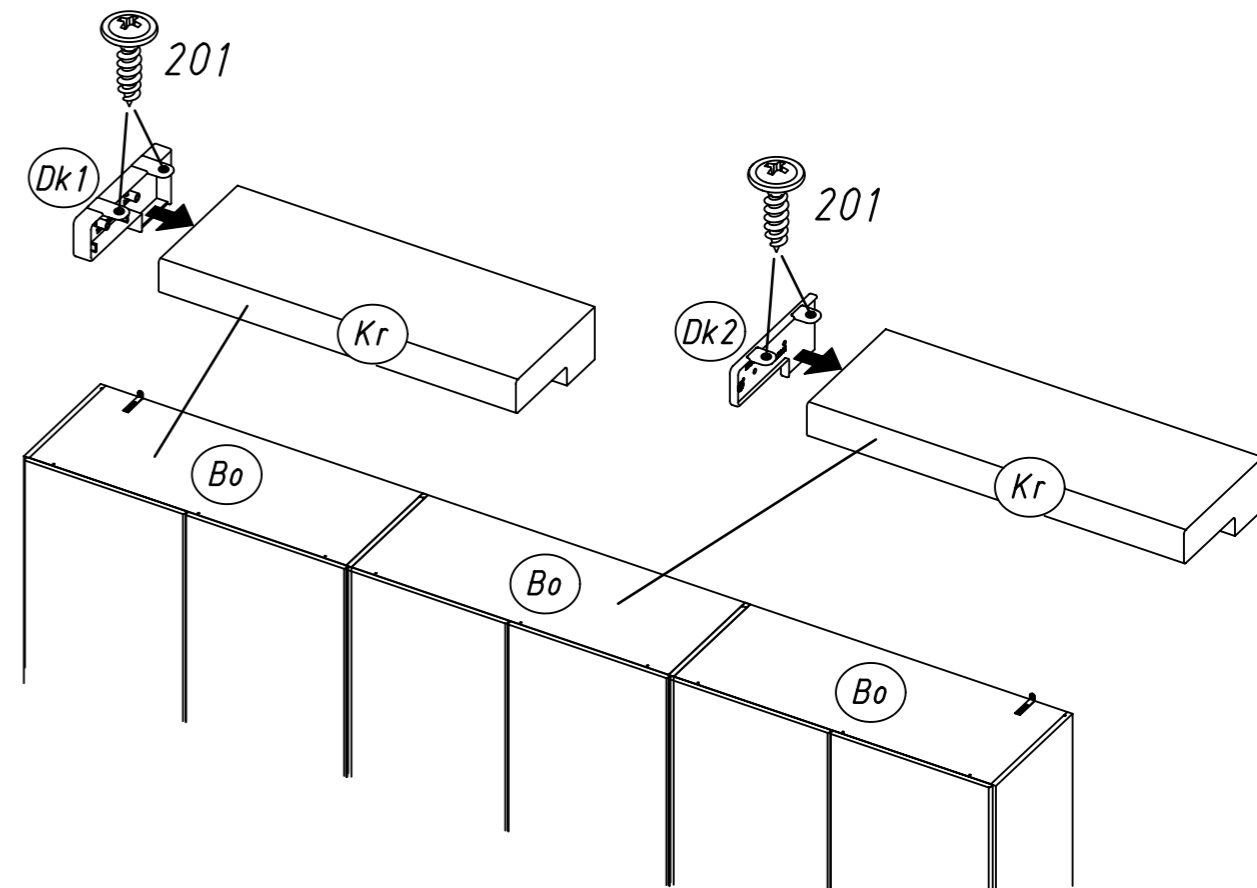
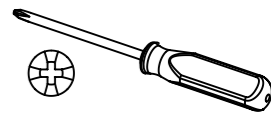

21

4 x

201



3 x

214

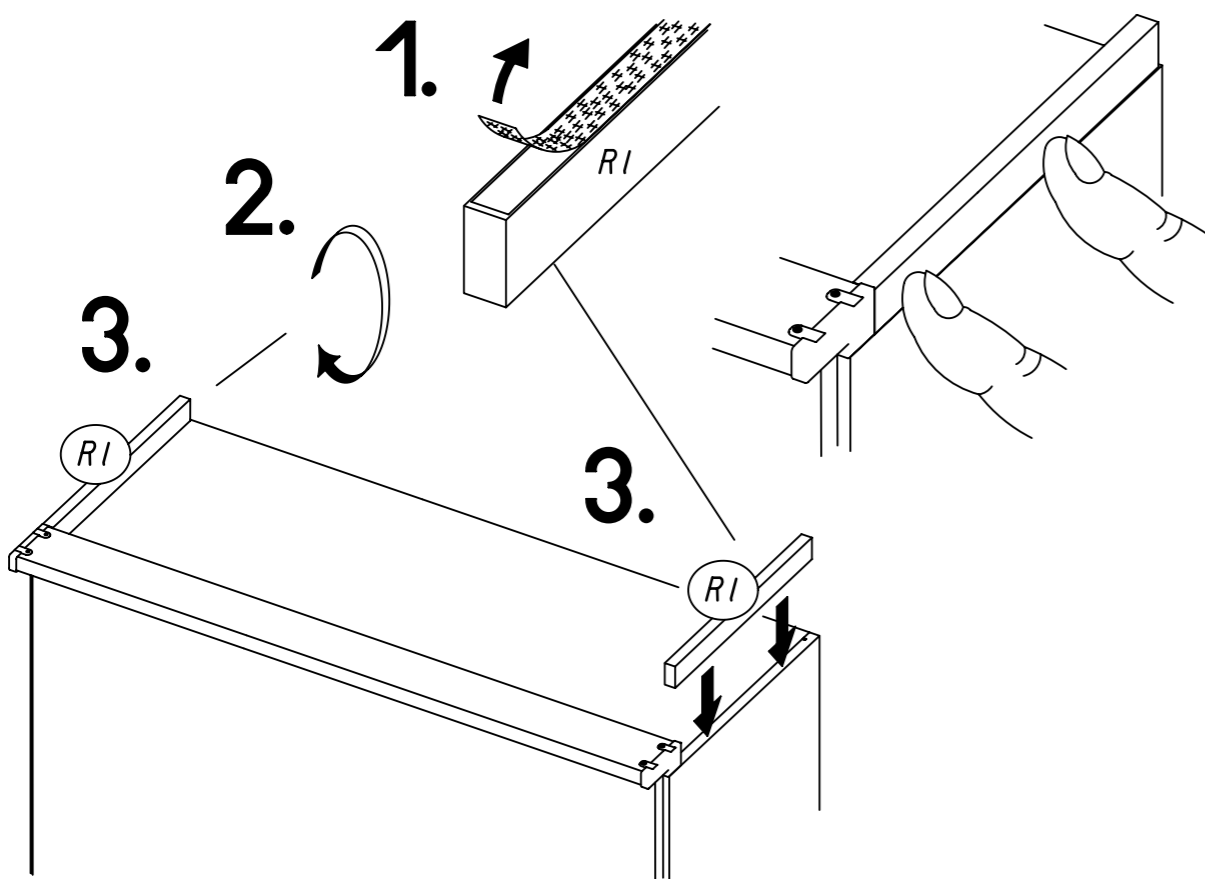
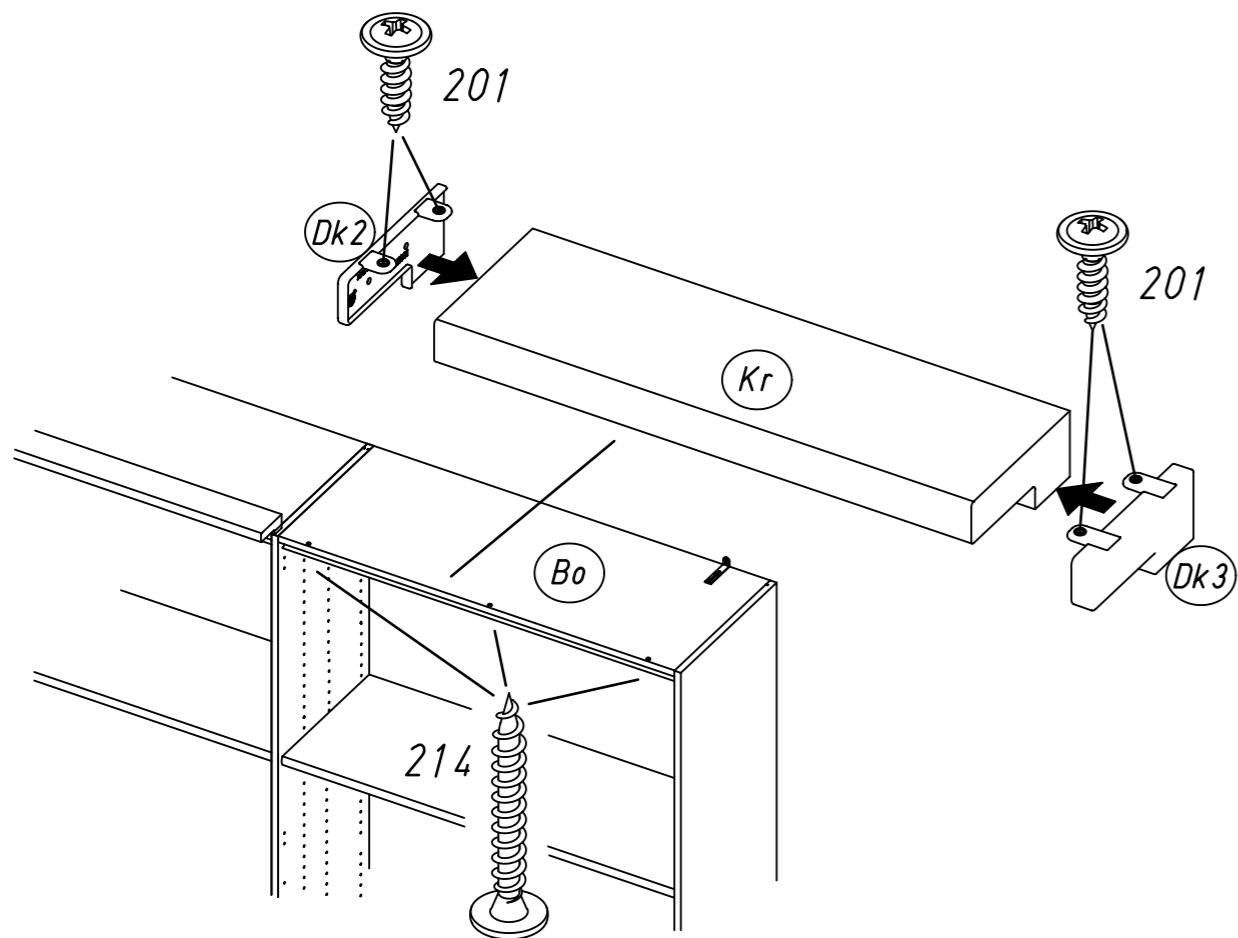
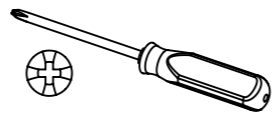
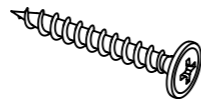

22

1.

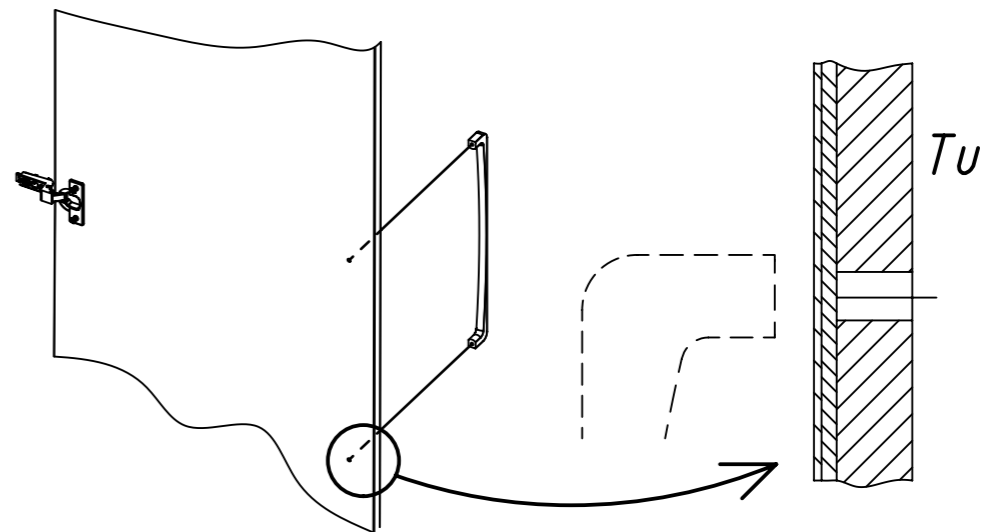

2.

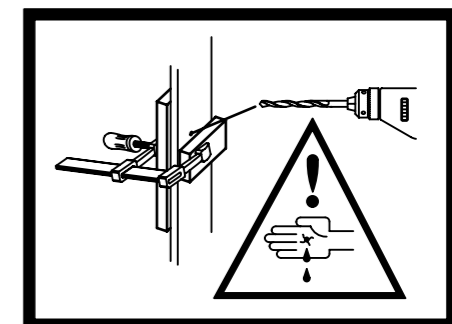
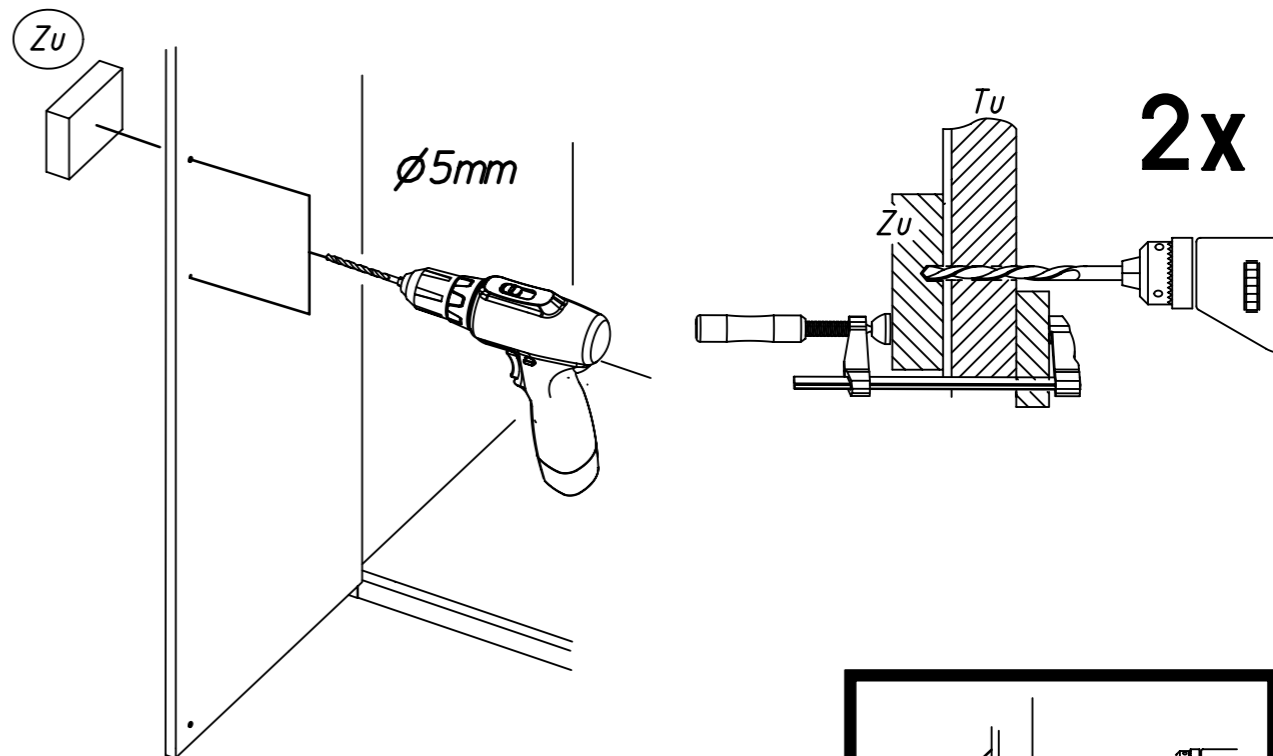

1.

M0851_03

rauch

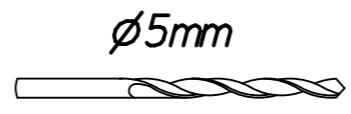
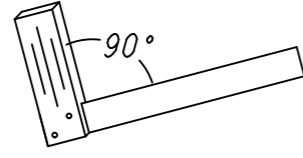
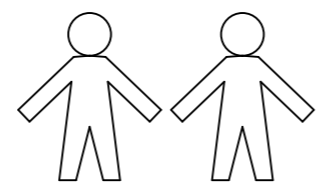
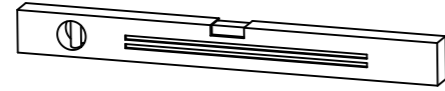
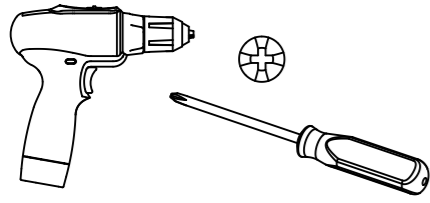

Ø5mm

Typ I

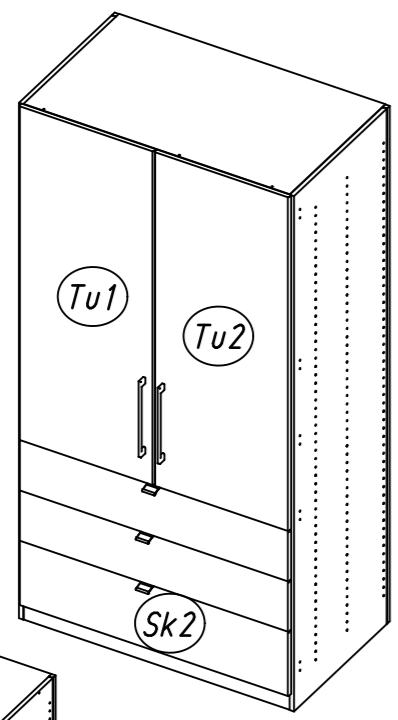

Typ II

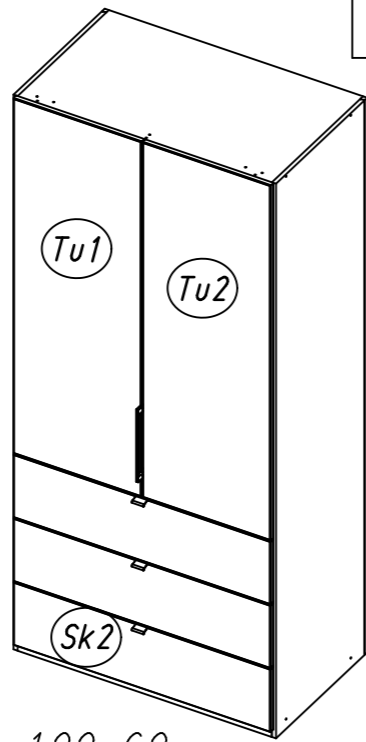

100x60cm

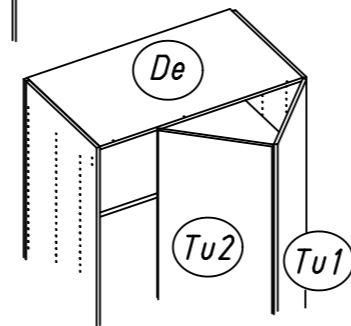
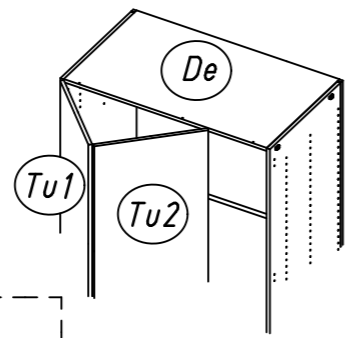
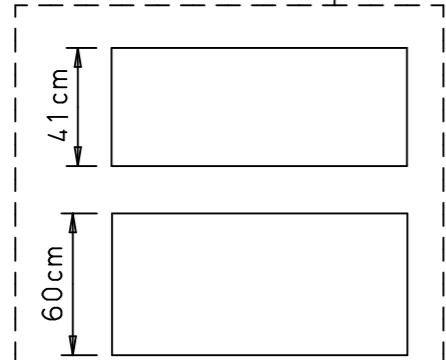
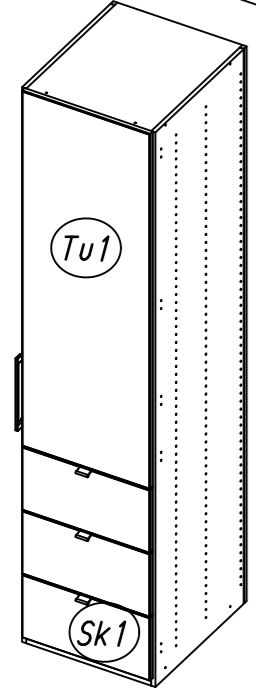

2.

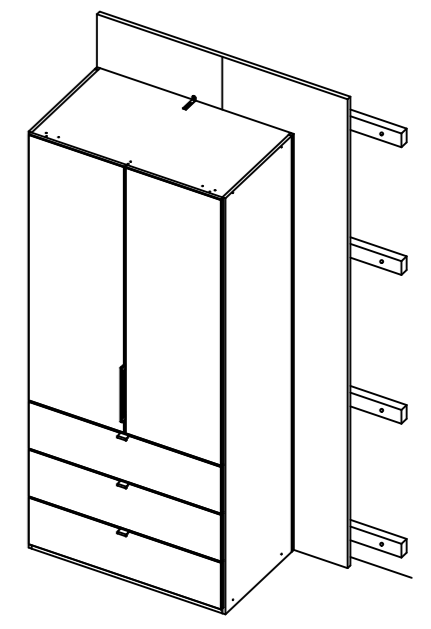
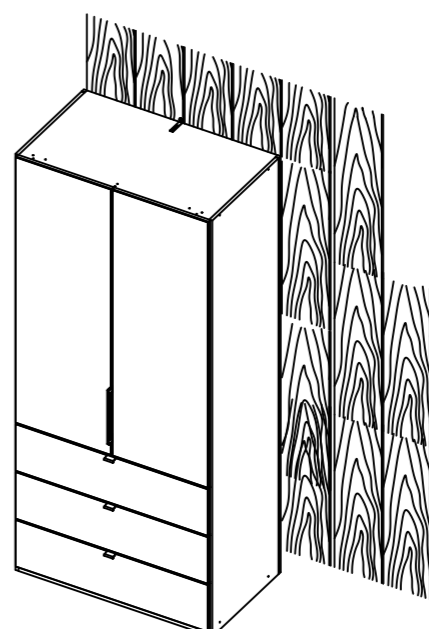
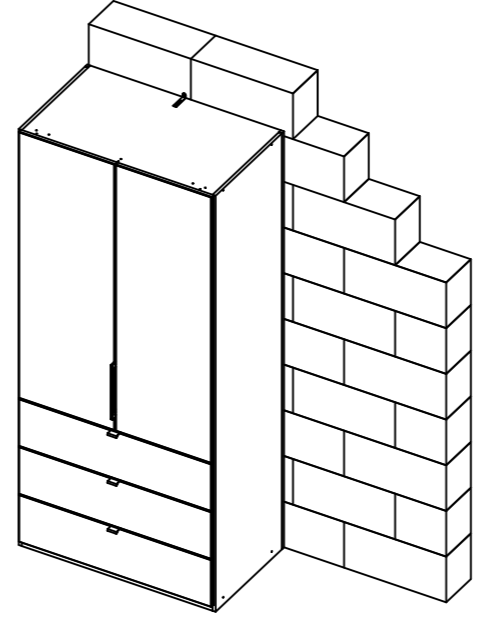
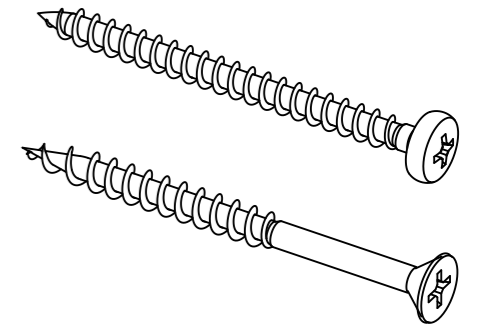
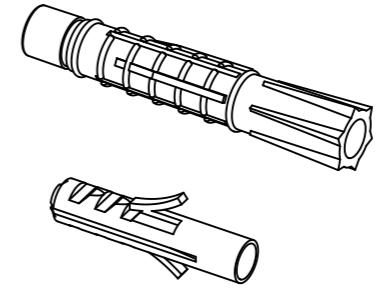
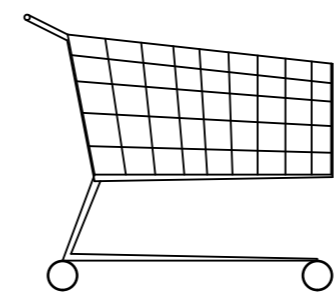
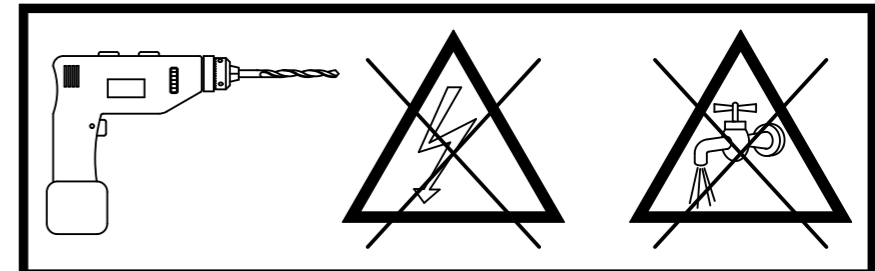
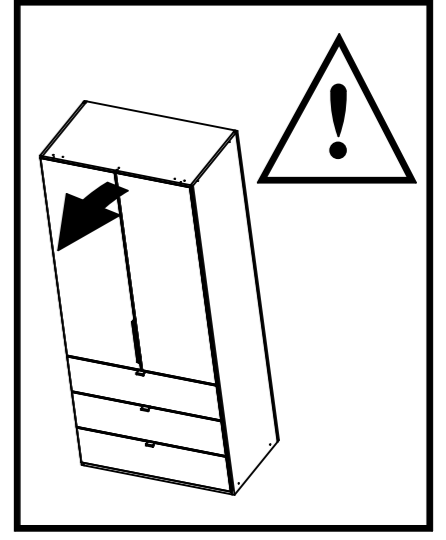
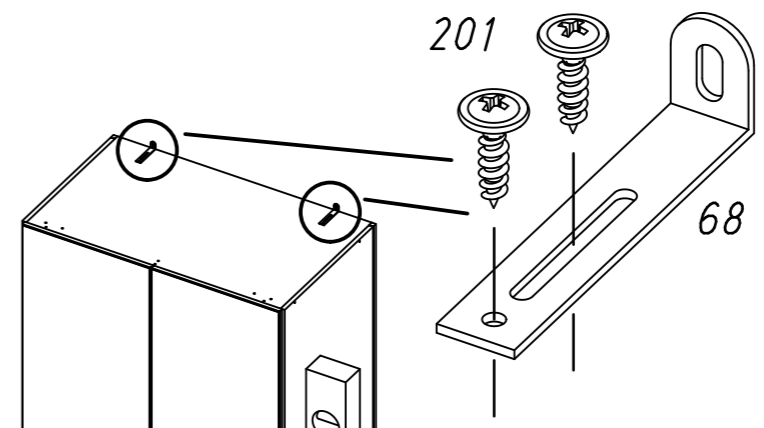

Typ I Typ II

<p>12</p> <p>55x16x6</p>		<p>29</p>		<p>47</p>		<p>201</p> <p>4x15</p>	
<p>205</p> <p>3,5x15</p>	<p>208</p> <p>3,5x15</p>	<p>382</p>	<p>565</p>				
<p>620</p>		<p>621</p> <p>4x13</p>	<p>775</p>	<p>779</p> <p>6,5x12</p>	<p>792</p> <p>6,3x9</p>	<p>836</p> <p>4x15</p>	<p>852</p>
<p>790</p> <p>! 60cm</p>				<p>791</p> <p>! 41cm</p>			
<p>1085</p>	<p>1086</p>	<p>1089</p>	<p>68</p> <p>77x15x22</p>	<p>Ks2</p> <p>Ks1</p> <p>x60cm</p>			

Typ II

<p>109</p>	<p>110</p>	<p>118</p>	<p>119</p>
<p>179</p> <p>6,3x13</p>	<p>580</p>	<p>581</p>	<p>757</p> <p>M4x30</p>
<p>676</p>		<p>677</p>	
<p>812</p> <p>118x35x11</p>		<p>934</p>	<p>935</p>
<p>Fs1</p>			<p>Fs2</p>



5.

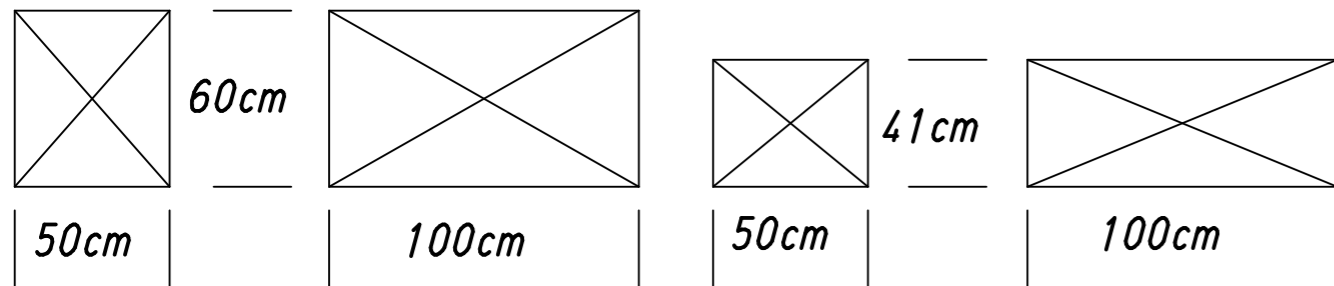

Typ I Typ II

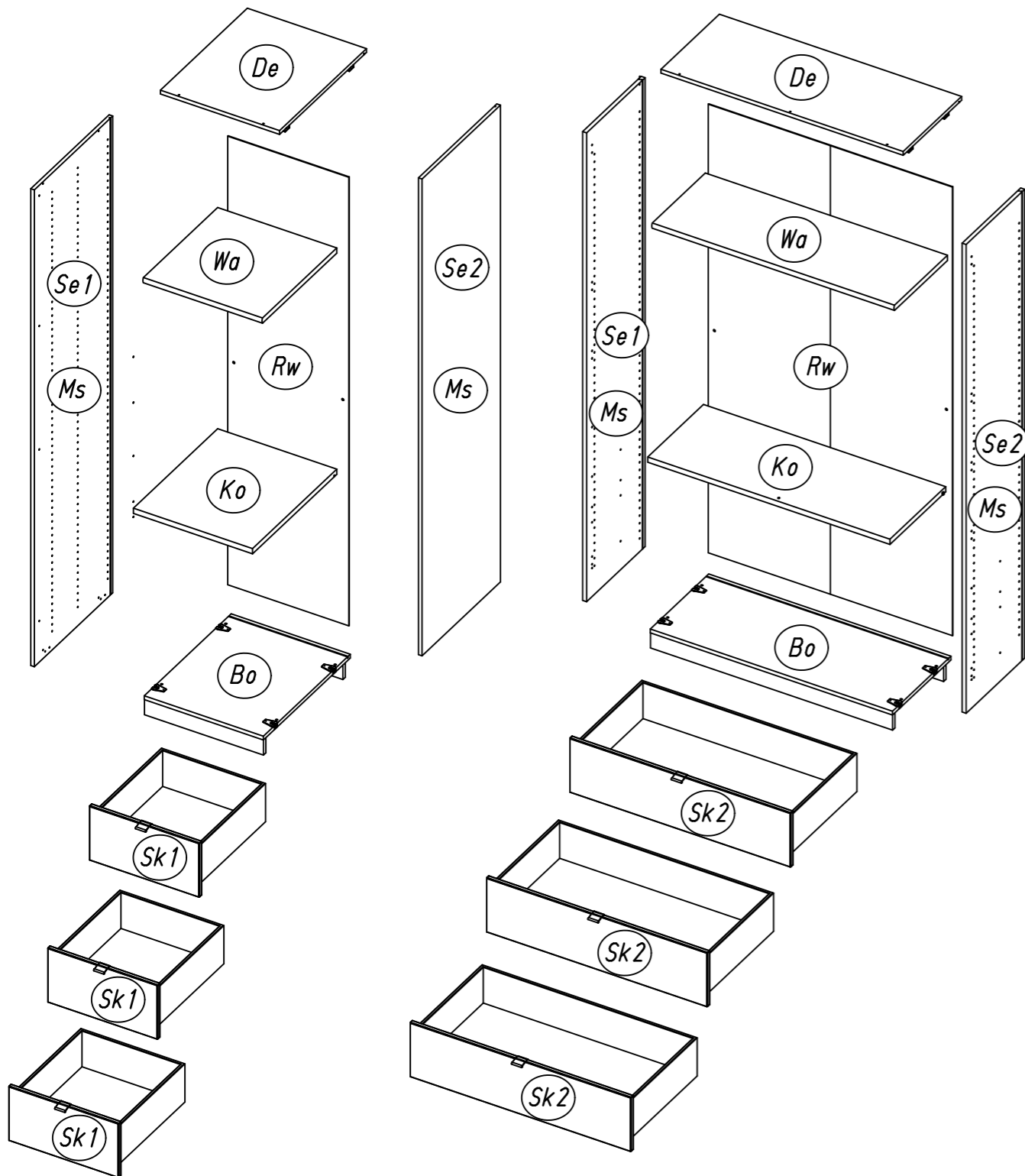

M0851

6.

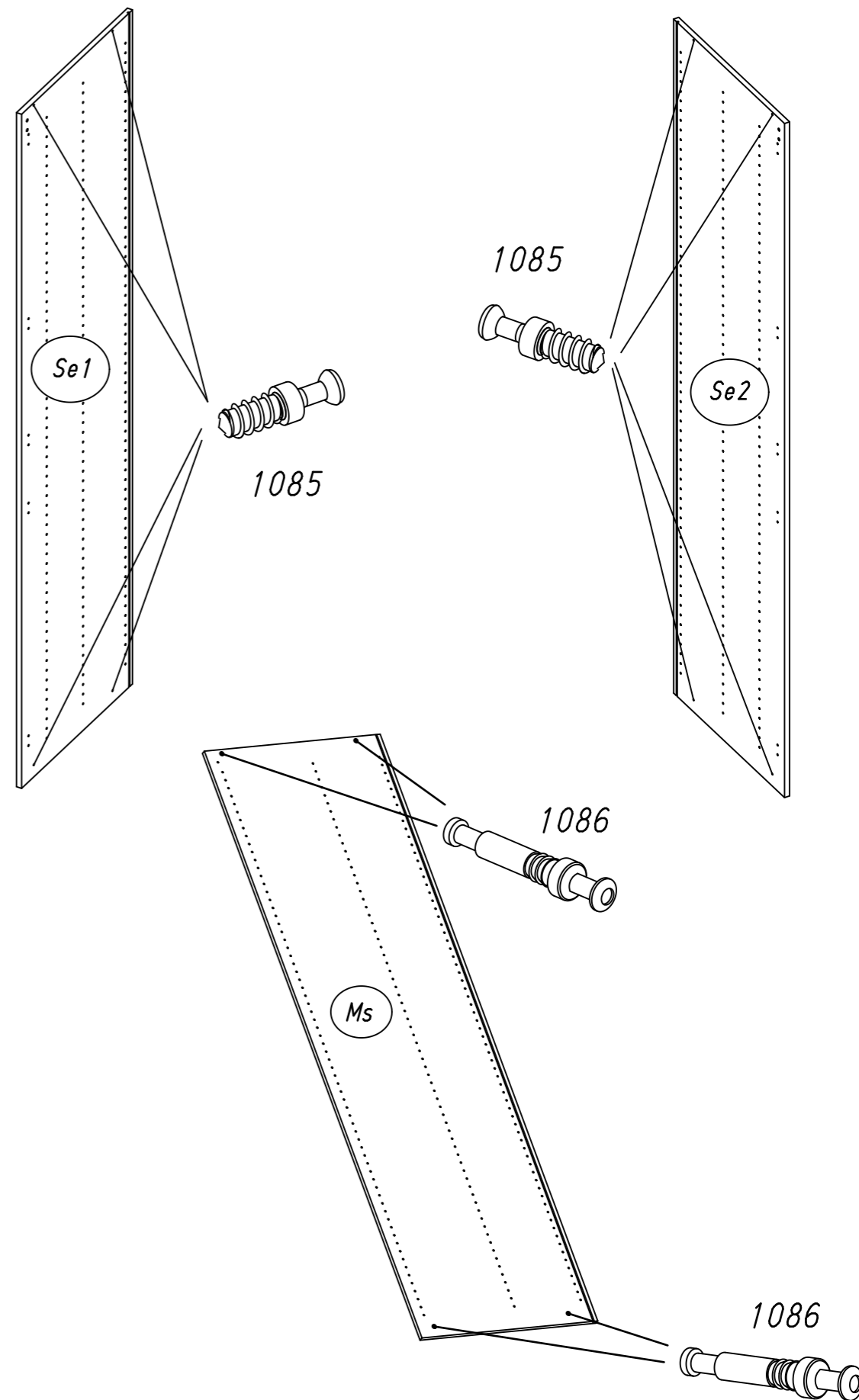
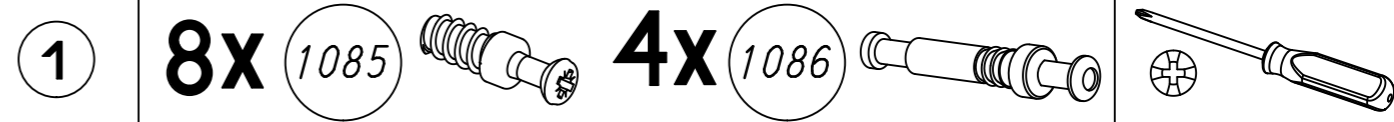

M0851

2

2x

47

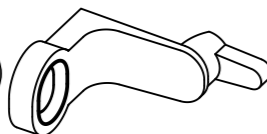

2x

779

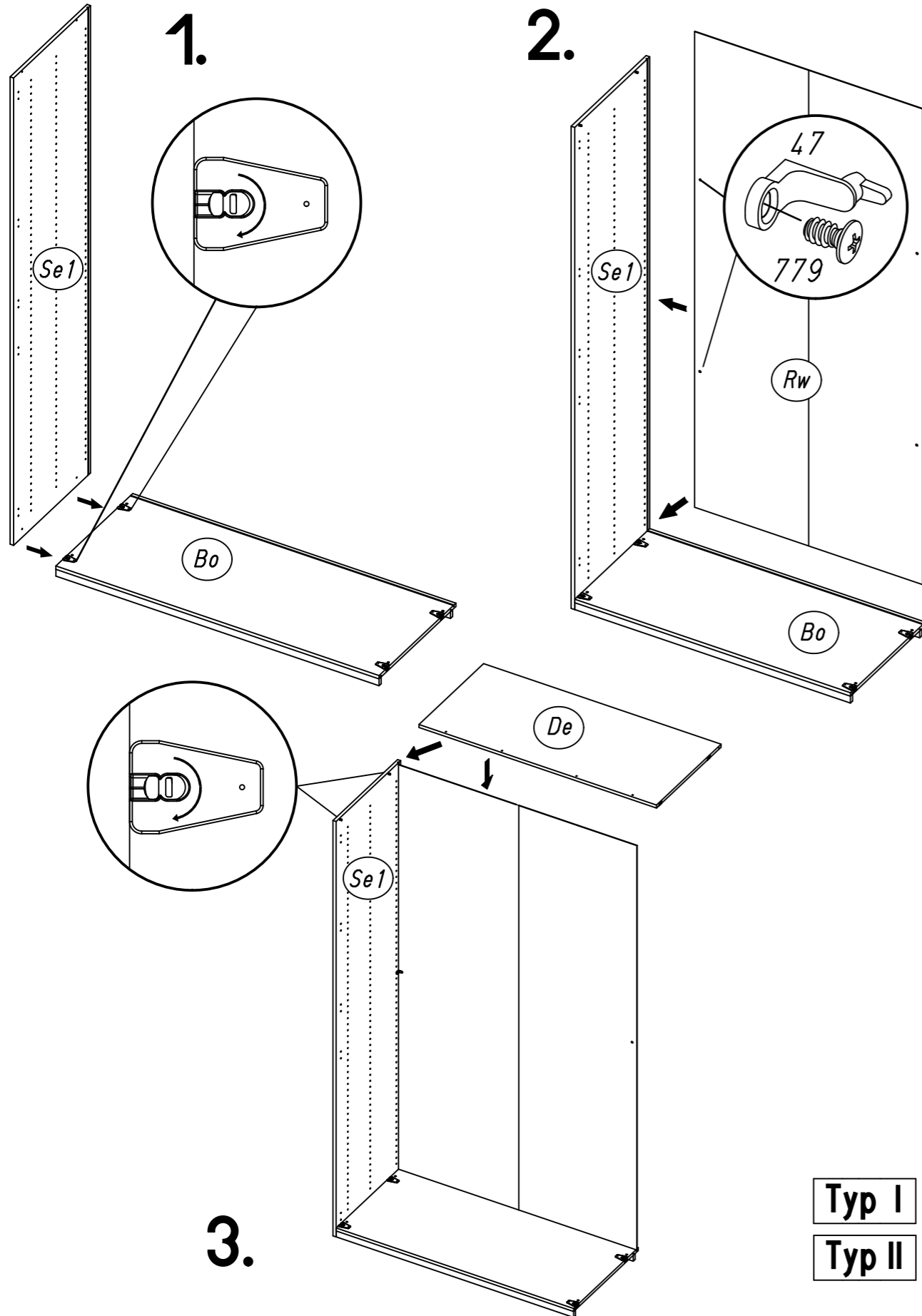
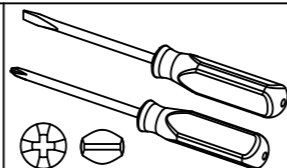
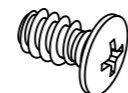

3

2x

47

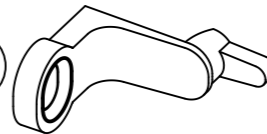

2x

779

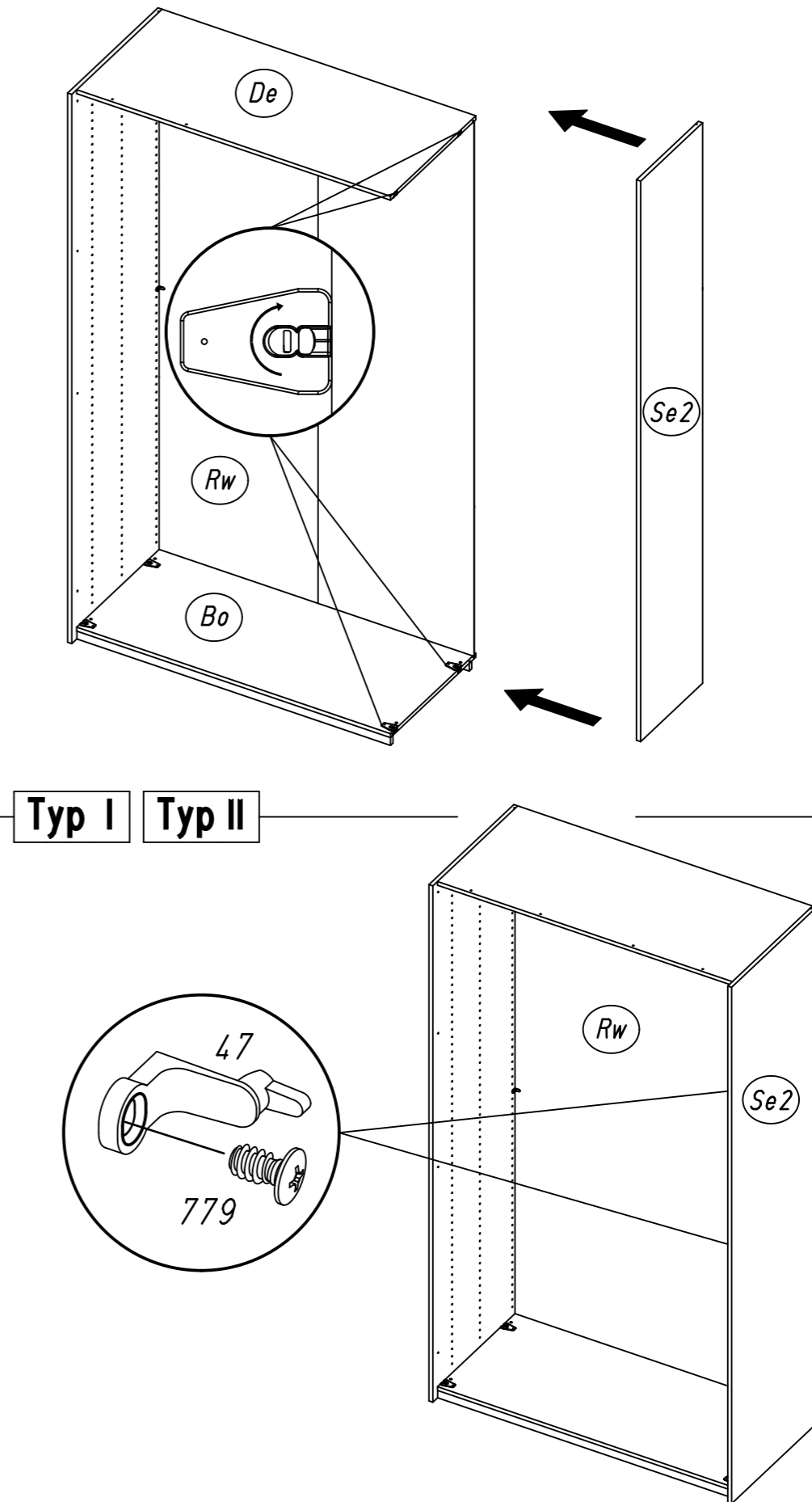
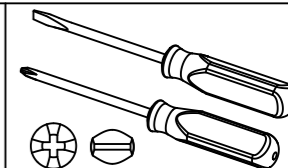

4

3x

179

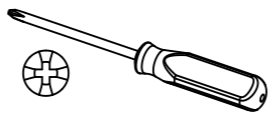
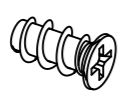

Typ II

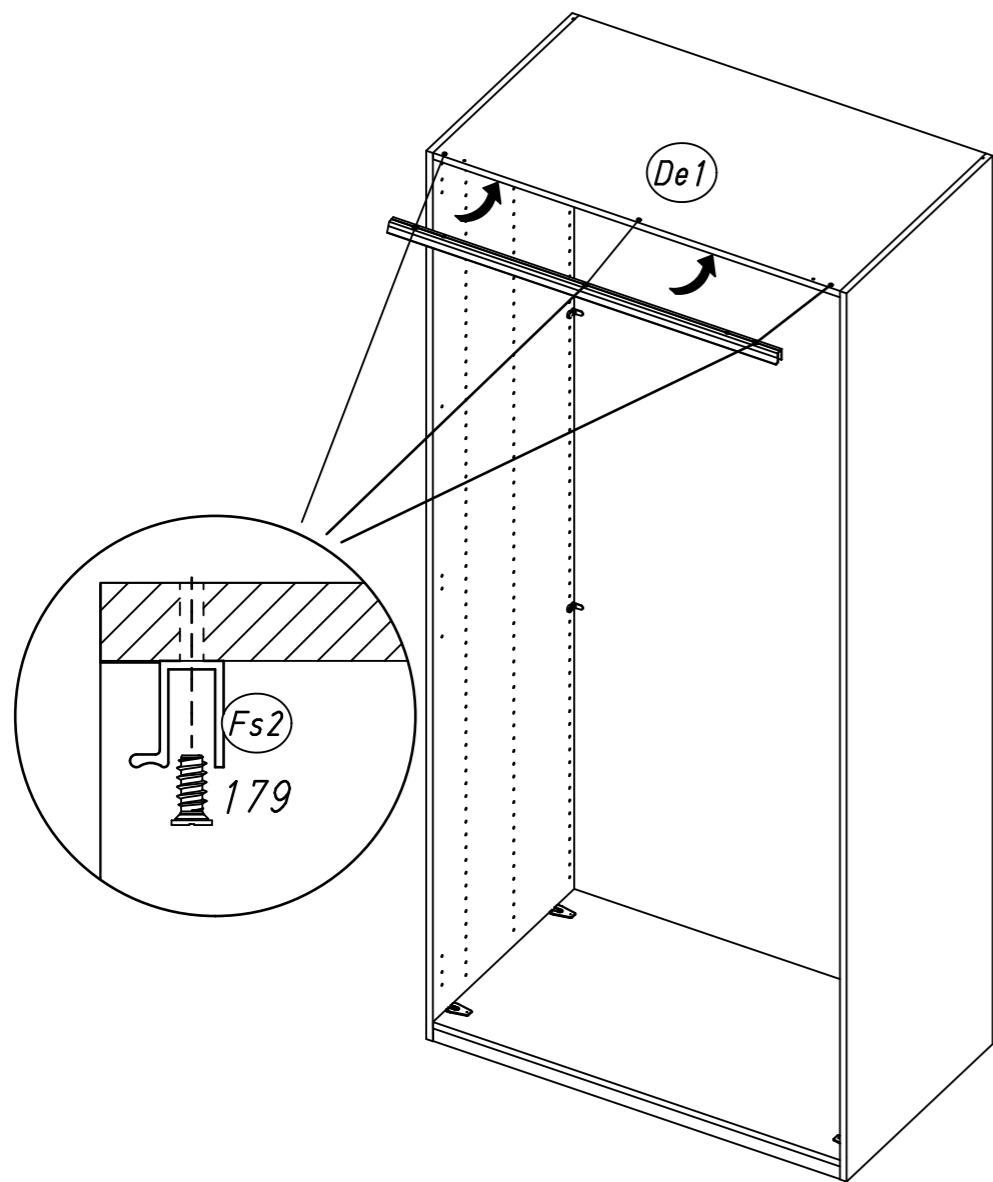

5

1x

580

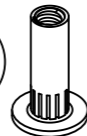

1x

581



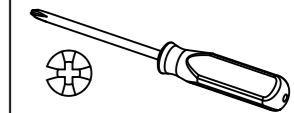
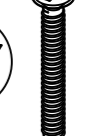

1x

757

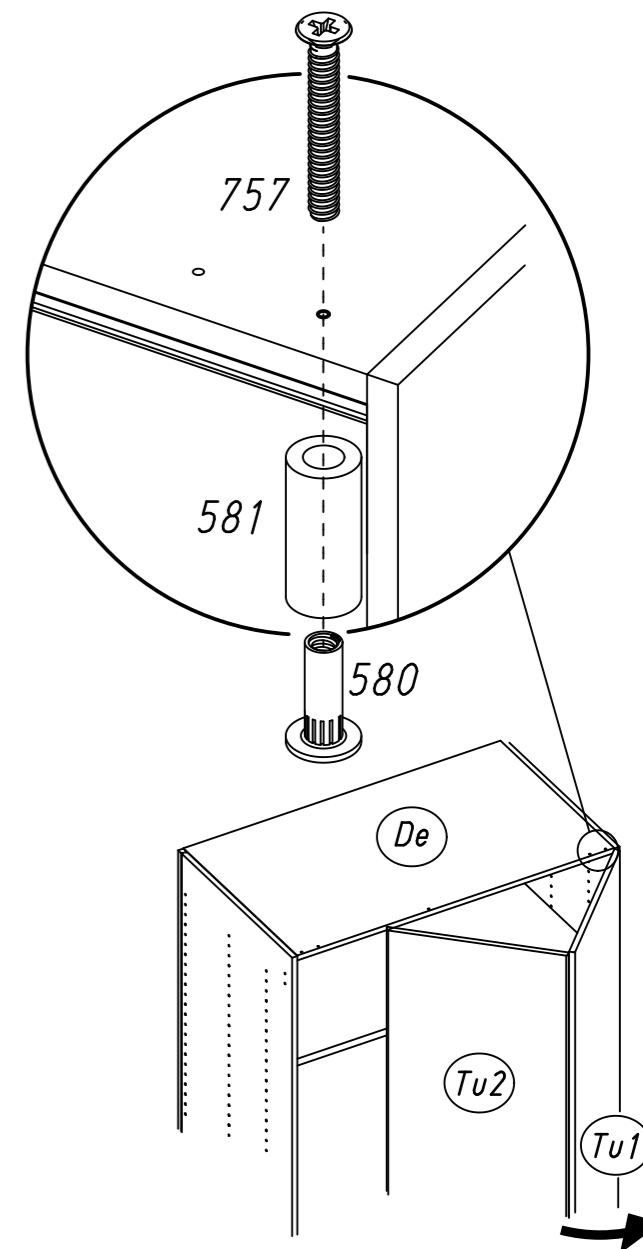
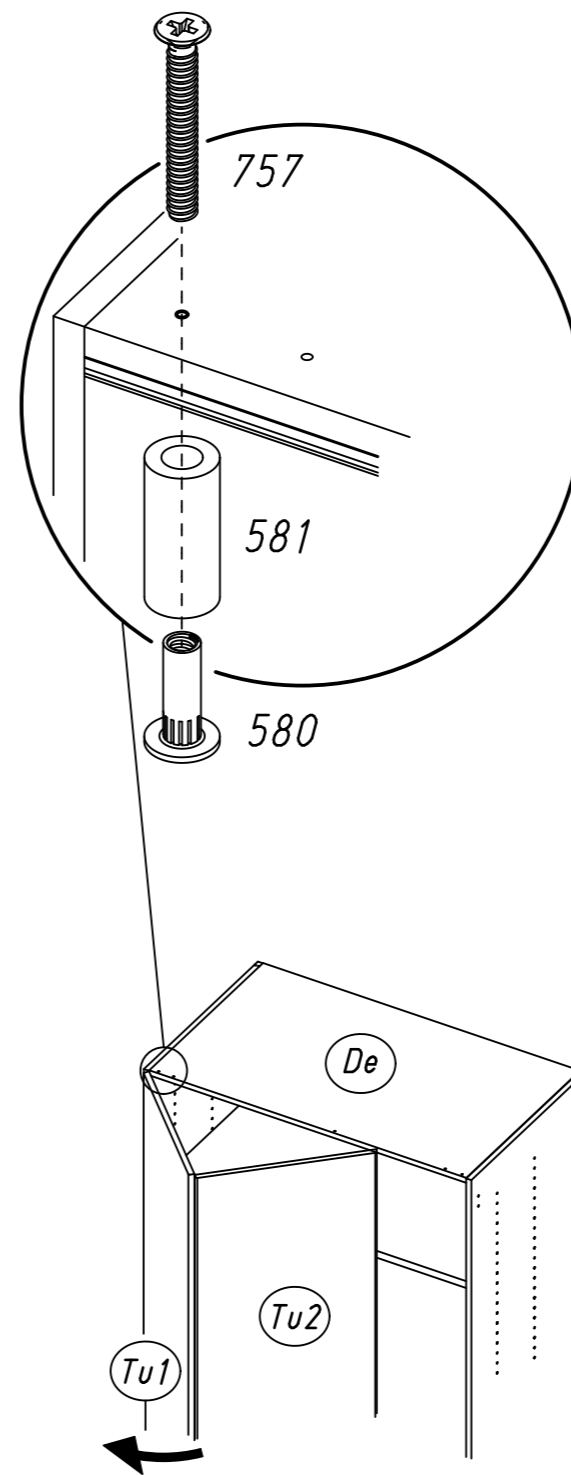

Typ II

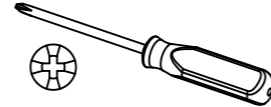

7 12x (836) 12x (792)   

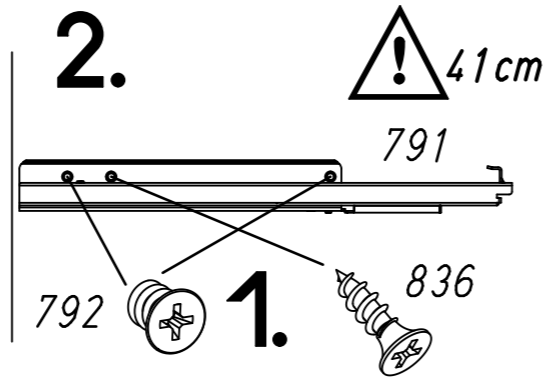
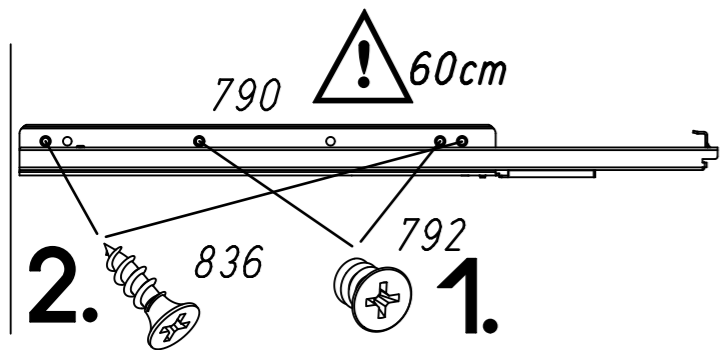

Typ I

Typ II

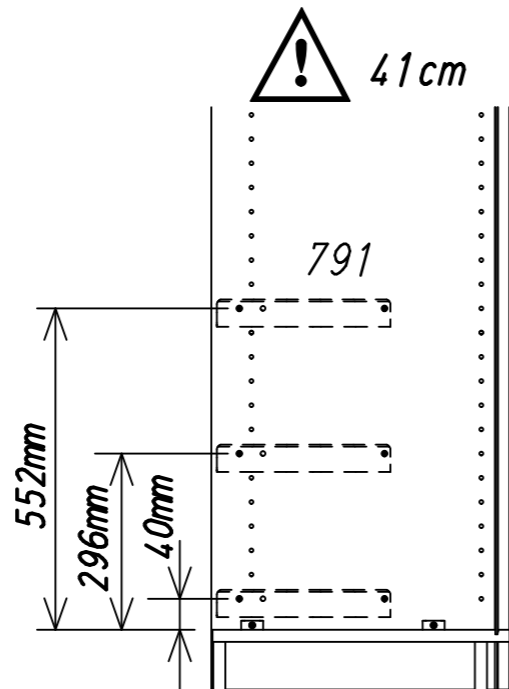
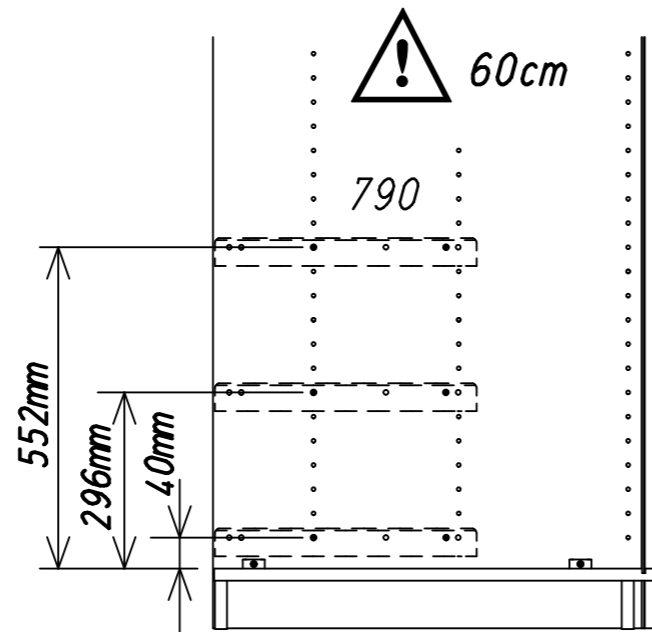
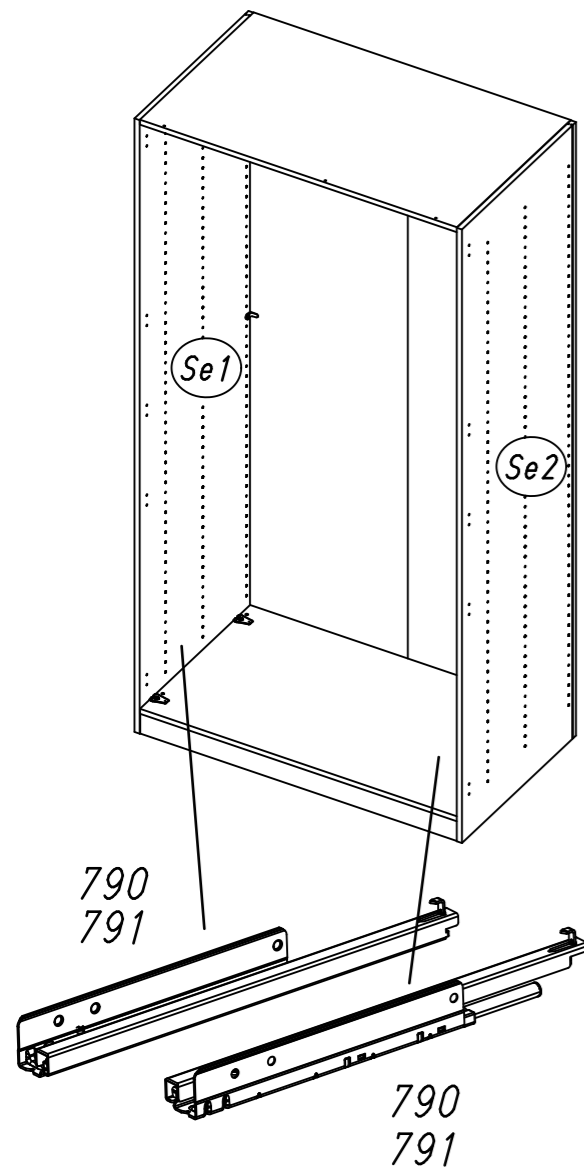

8 4x (1089) 6x (208)   

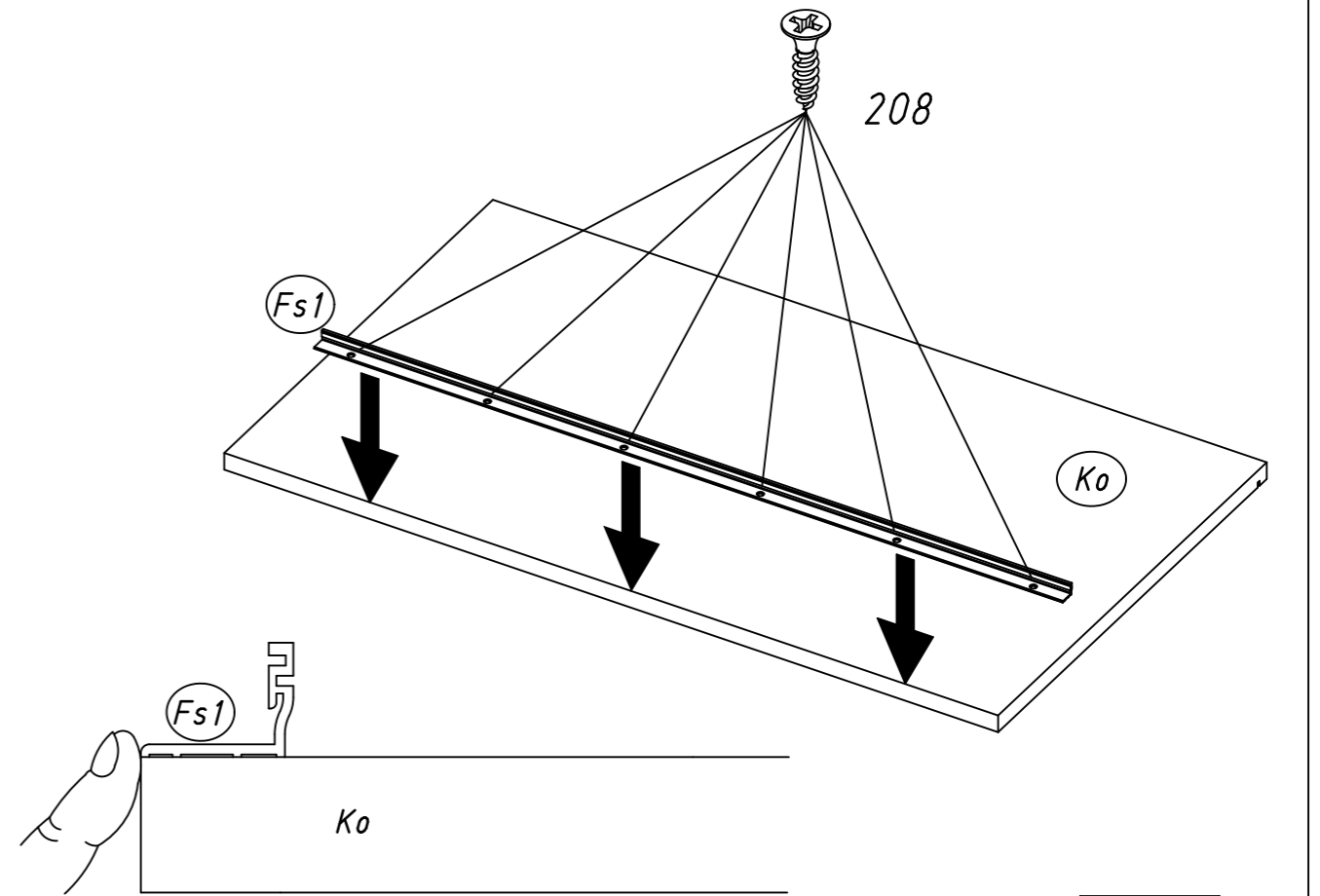
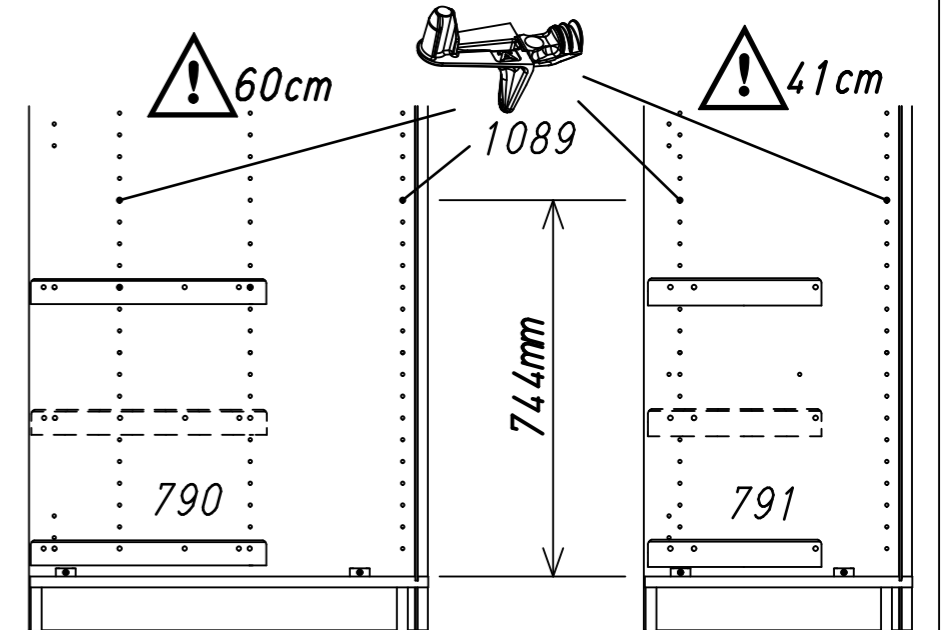
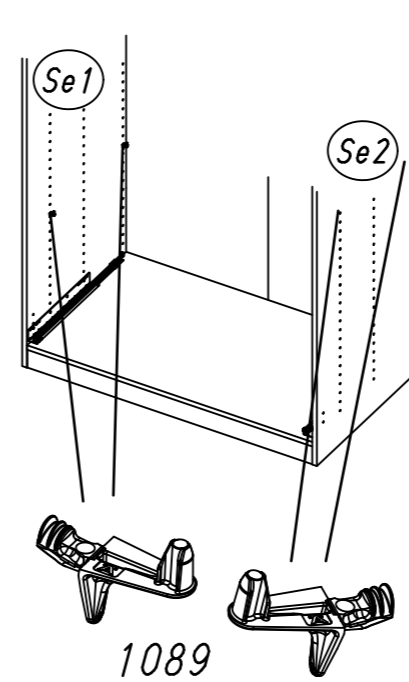

Typ II

9

Typ I
Typ II

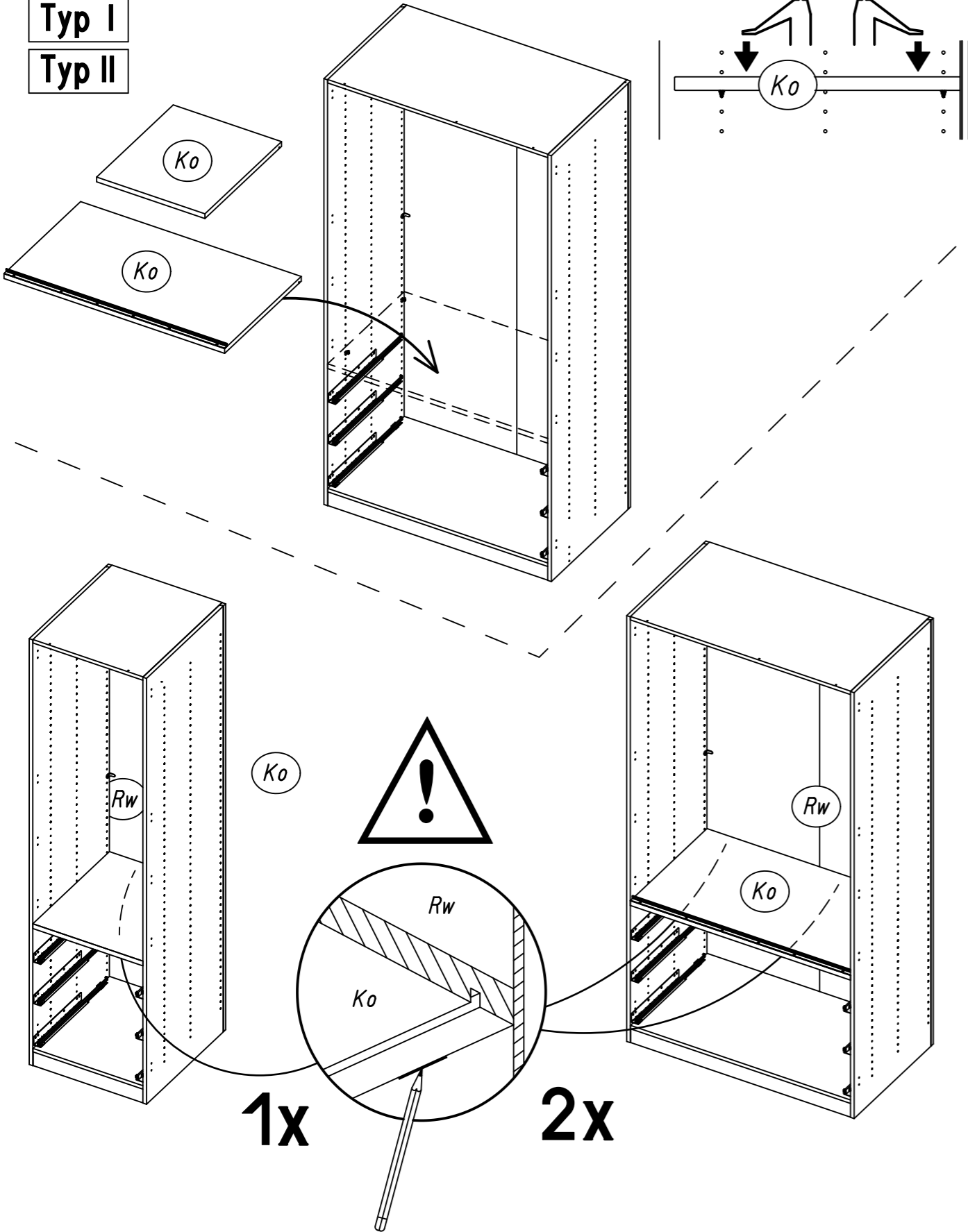

10

2x 201 2x 775

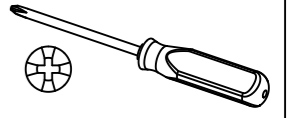
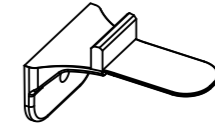

Typ I
Typ II

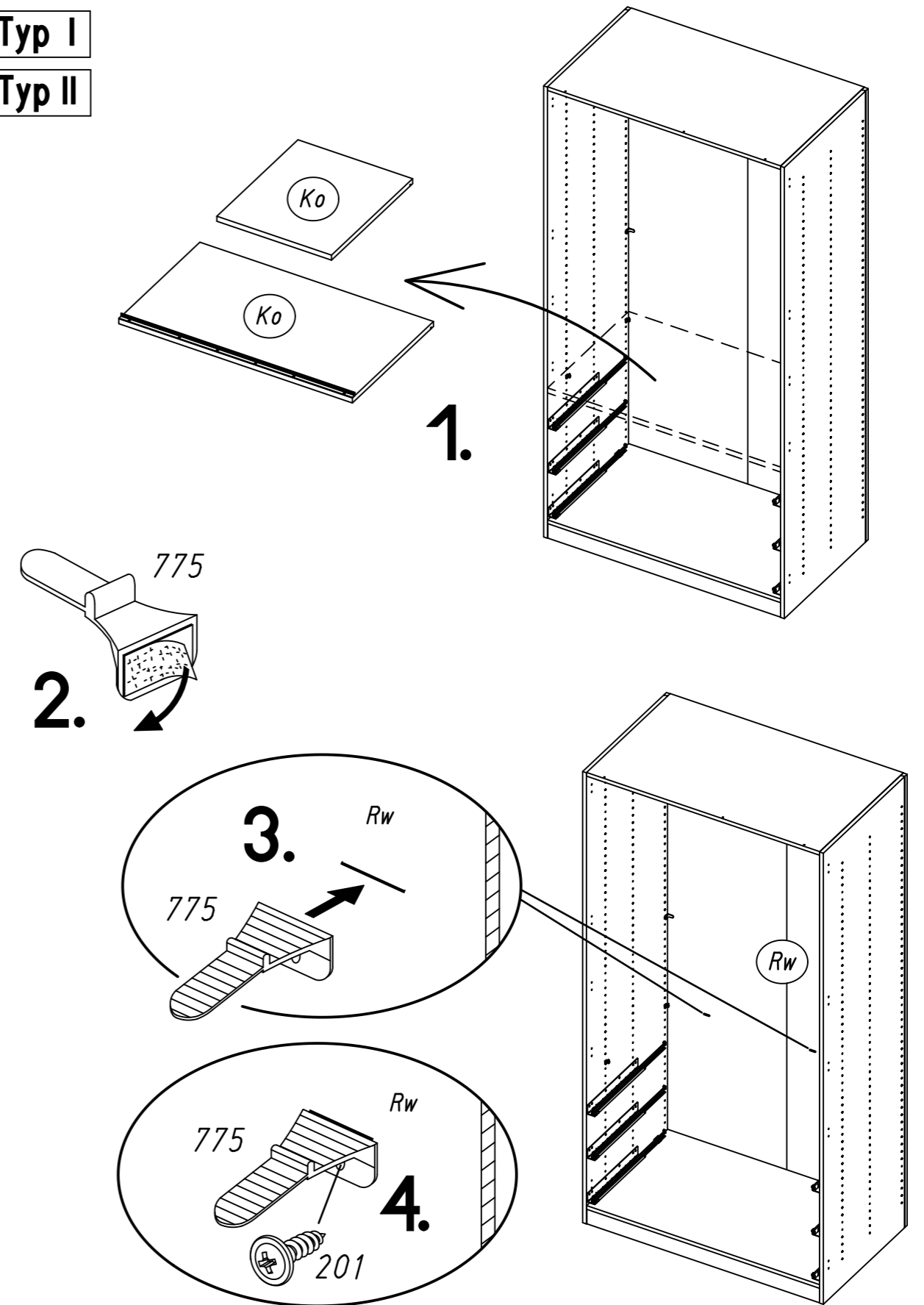

11

2x 382



2x 836

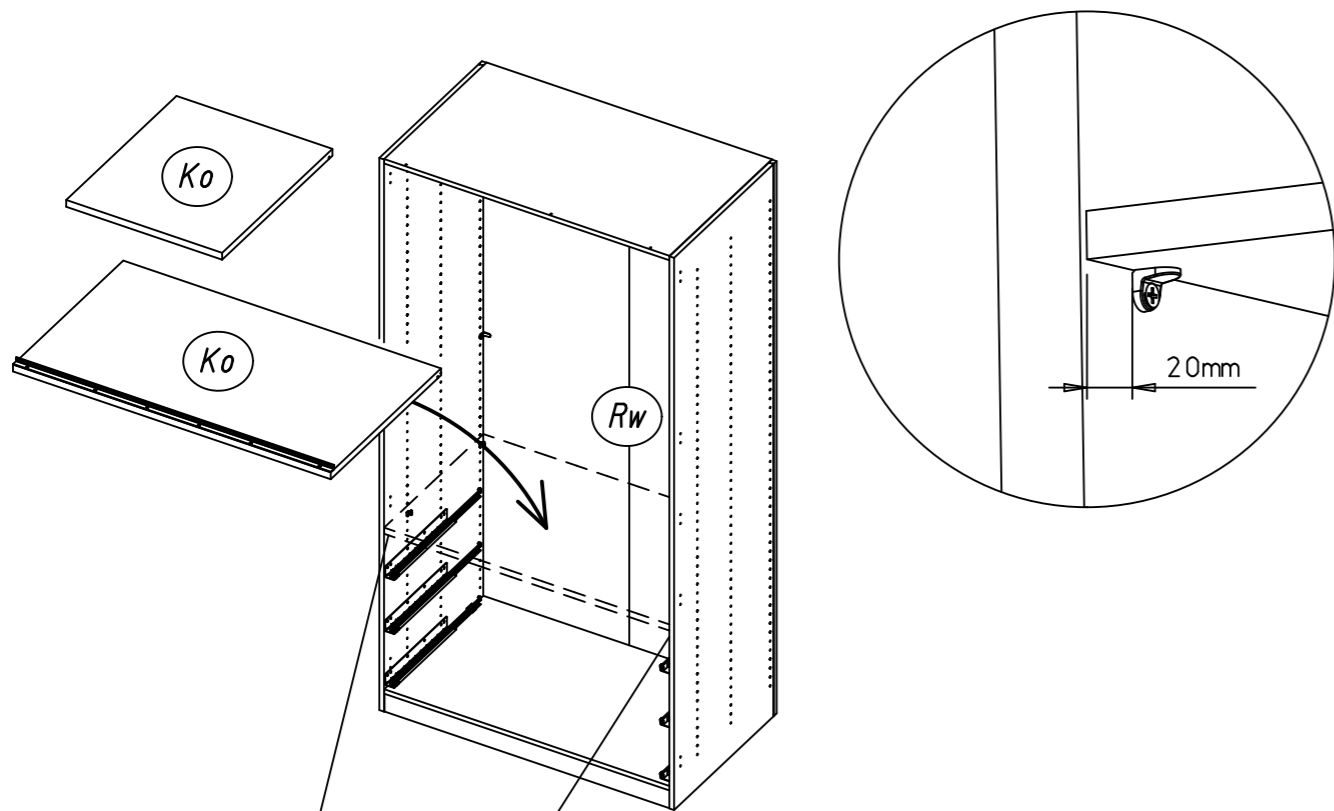
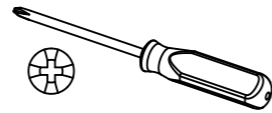

4.

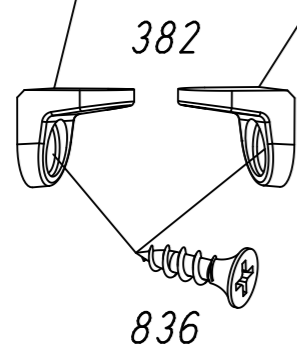

1.

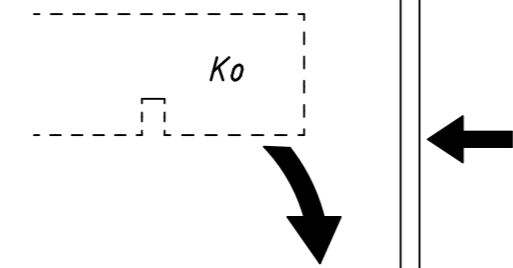

2.

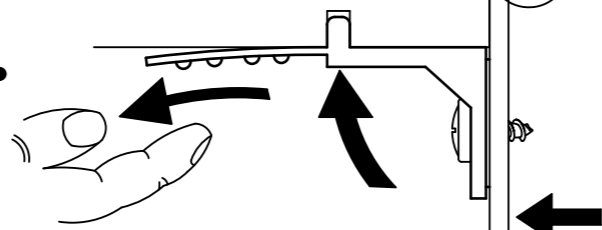

3.

Typ I

Typ II

12

2x 205



2x 29



4x 1089

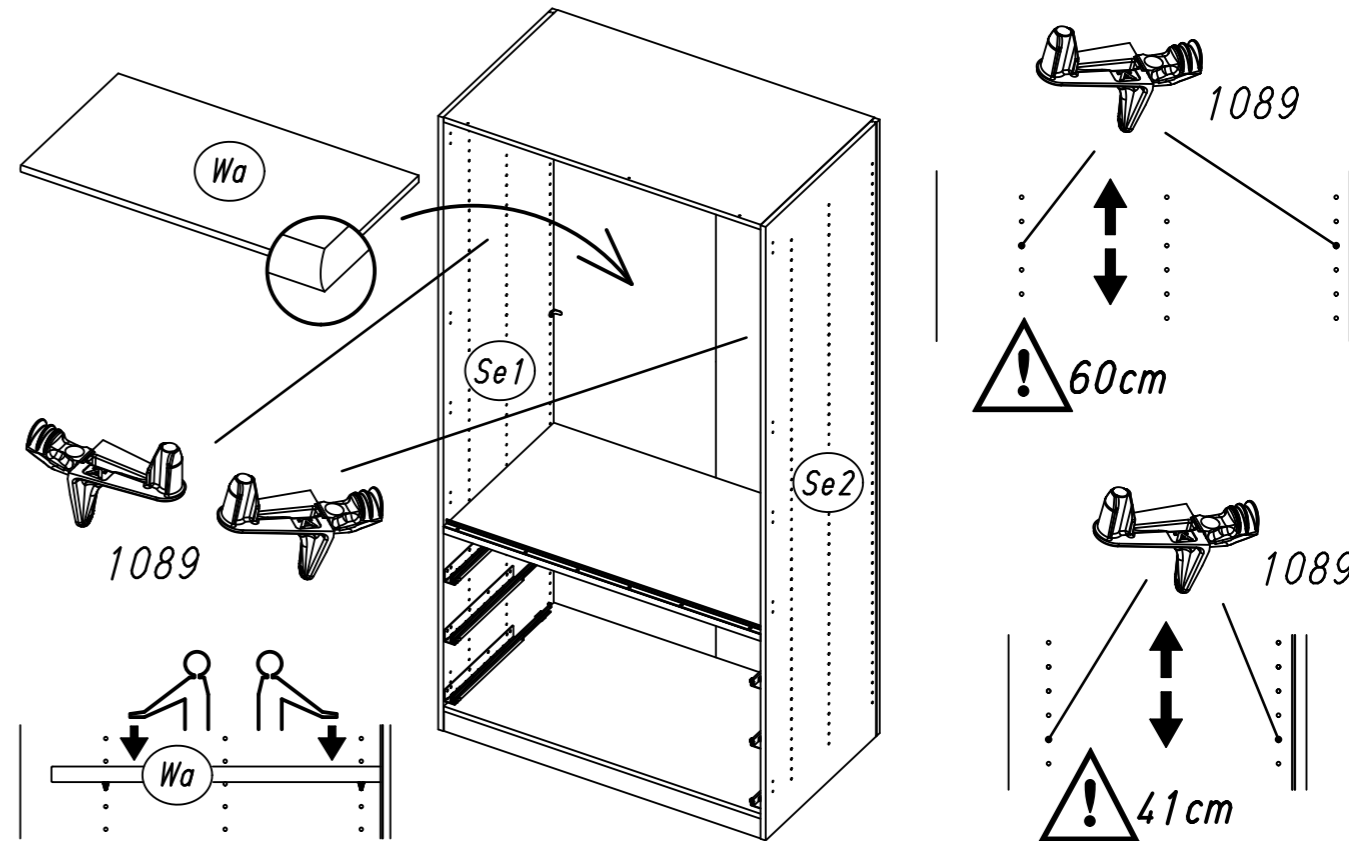
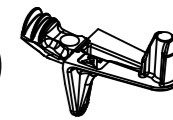

Typ I Typ II

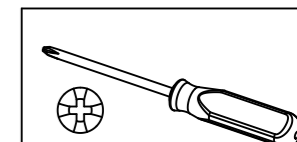
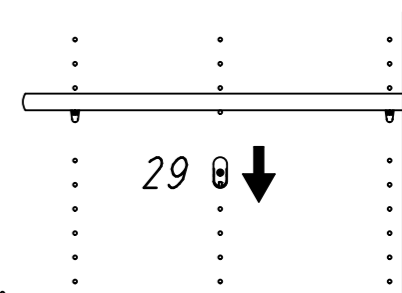
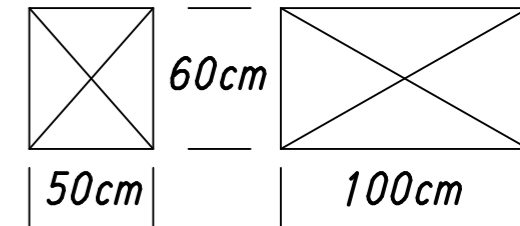
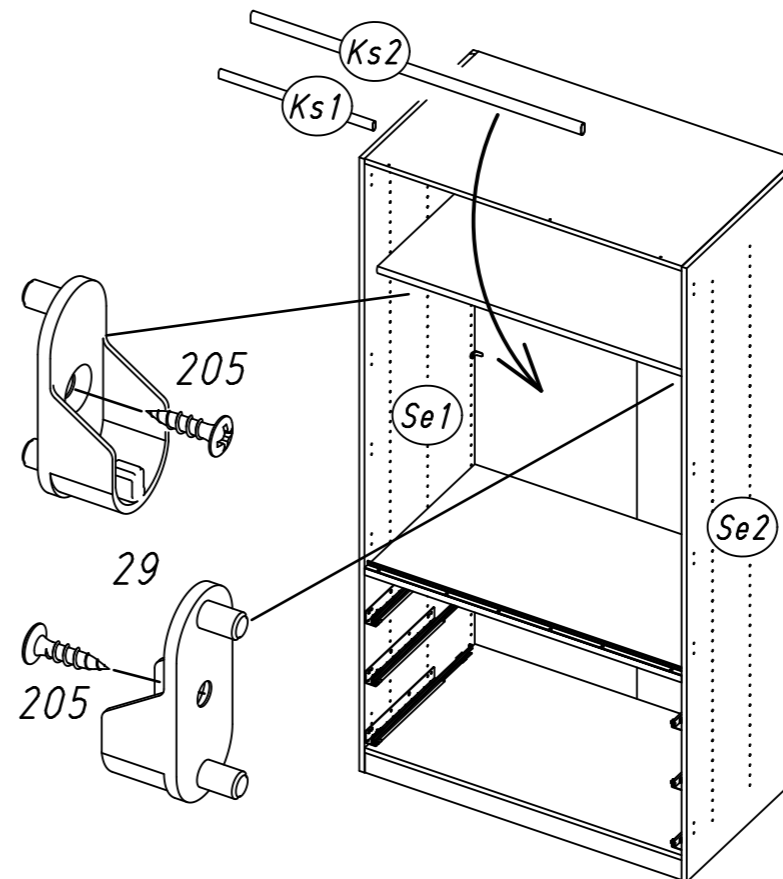

13

6x

852

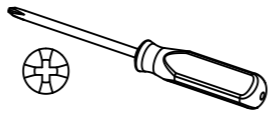
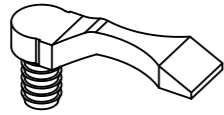

Typ I

Typ II

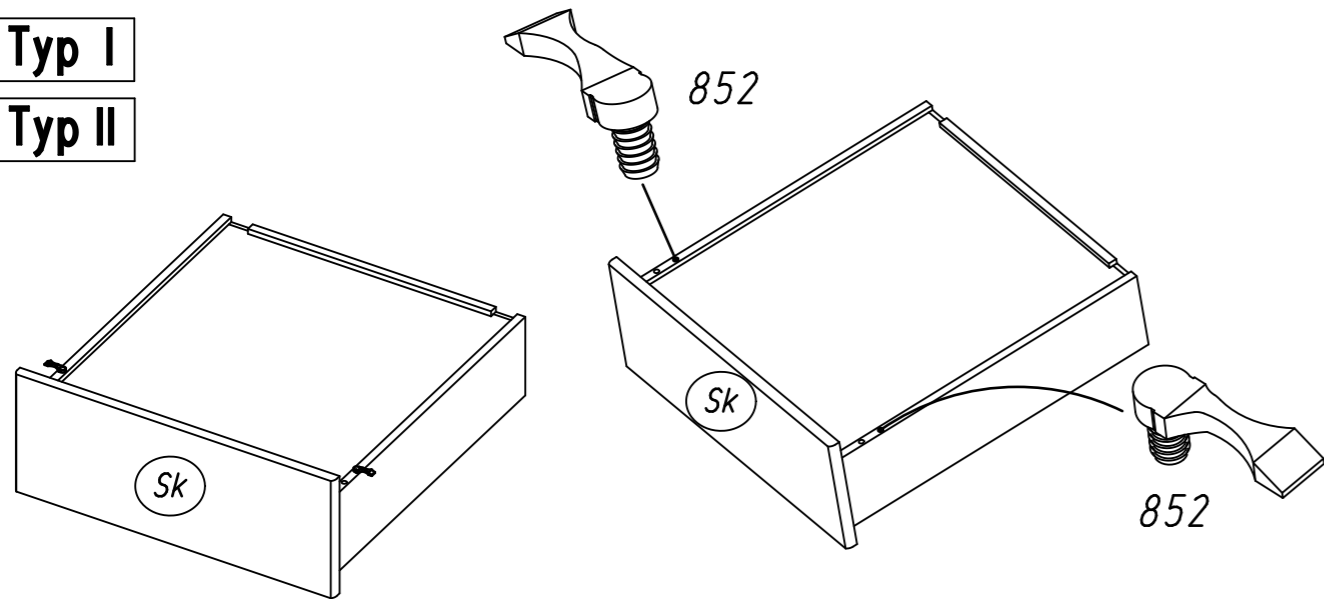

14

Typ I

Typ II

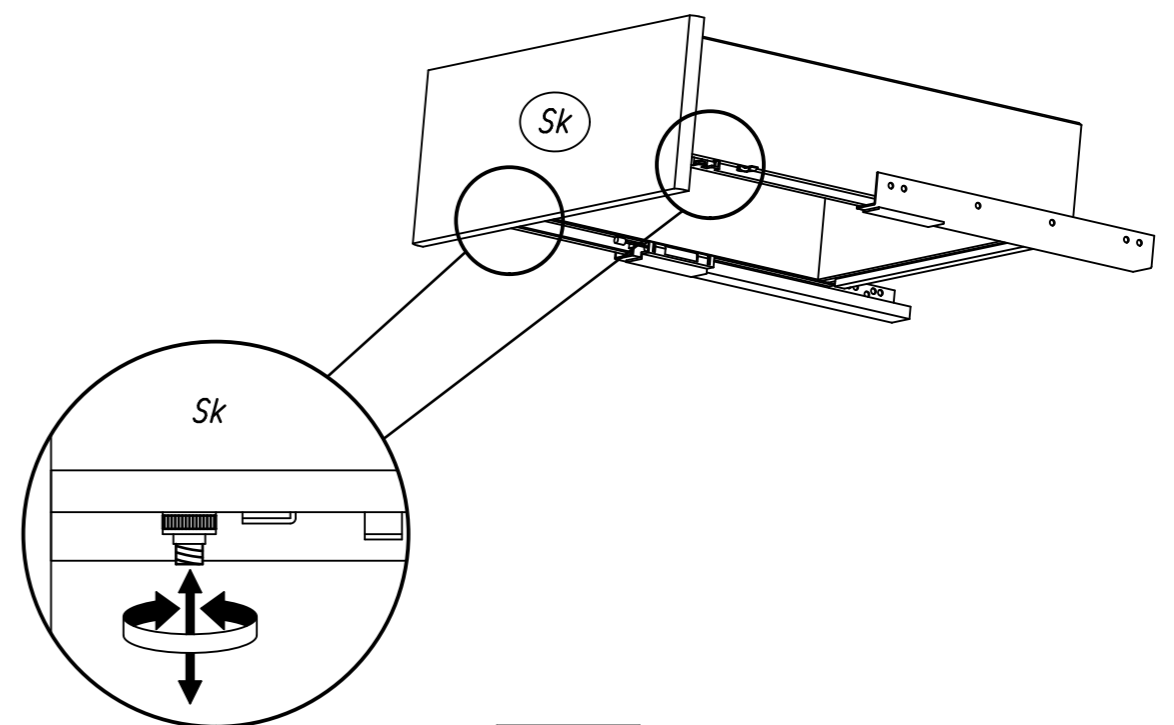
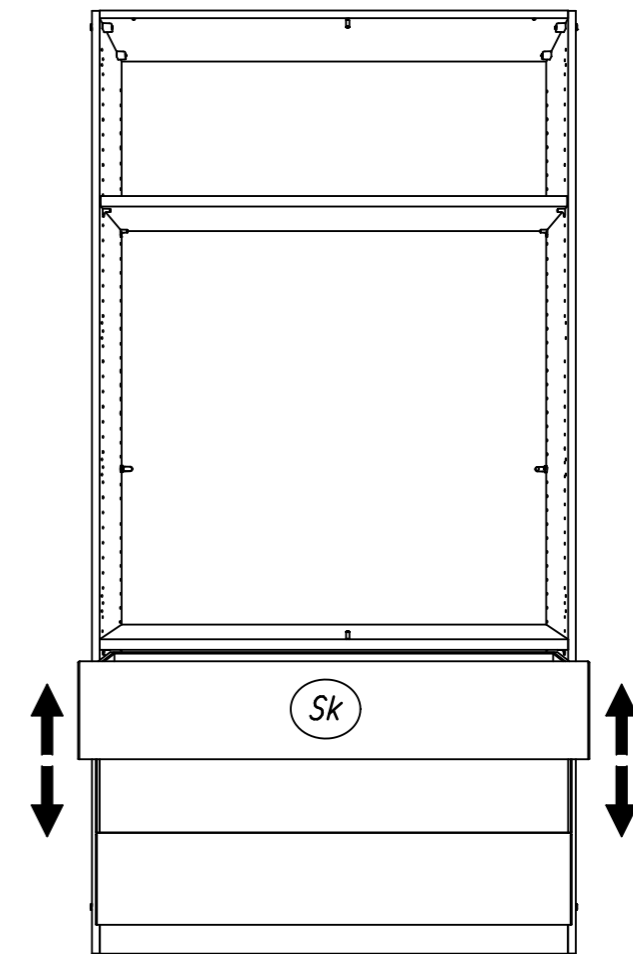
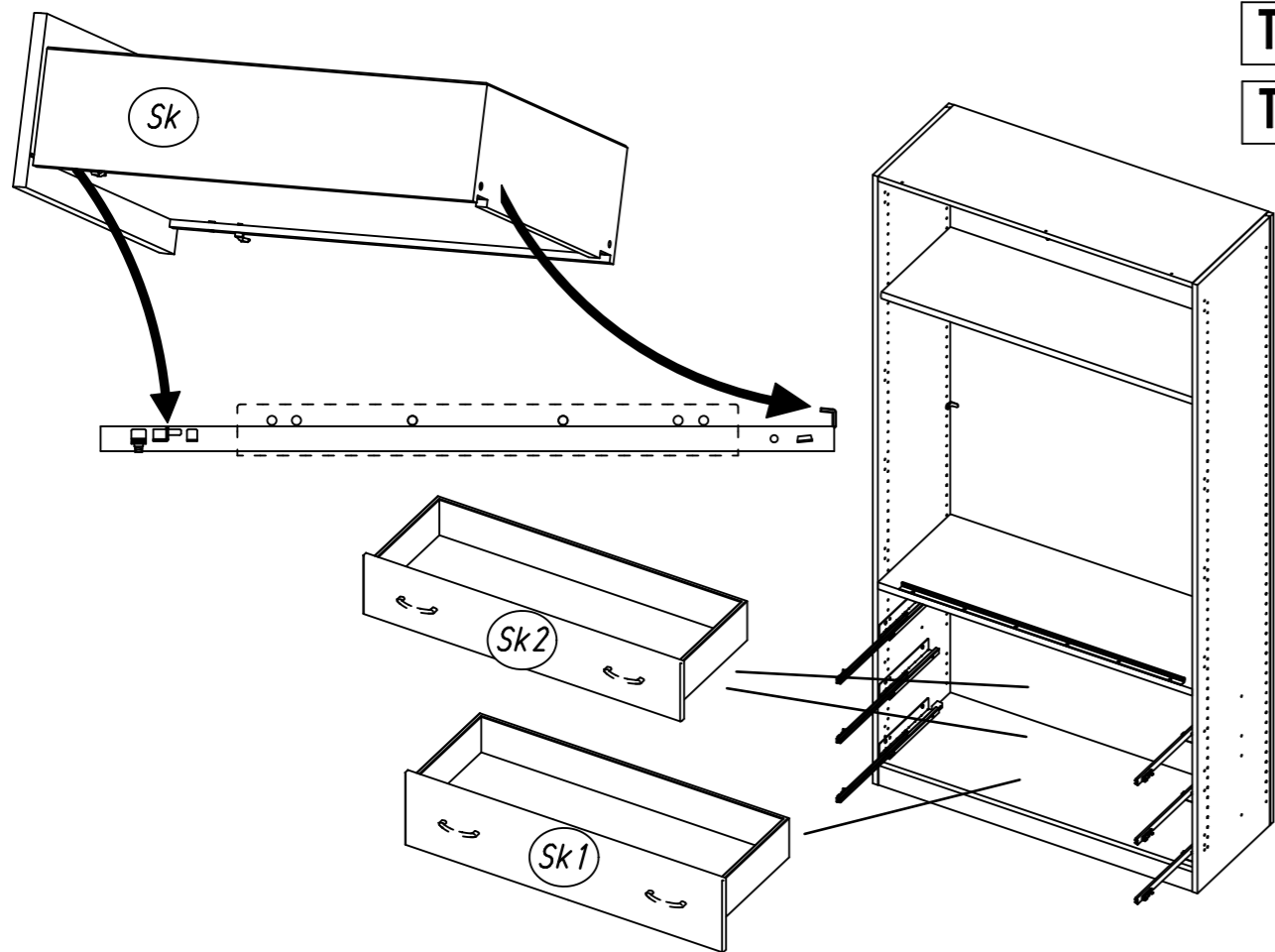

Typ I

Typ II

Typ I Typ II

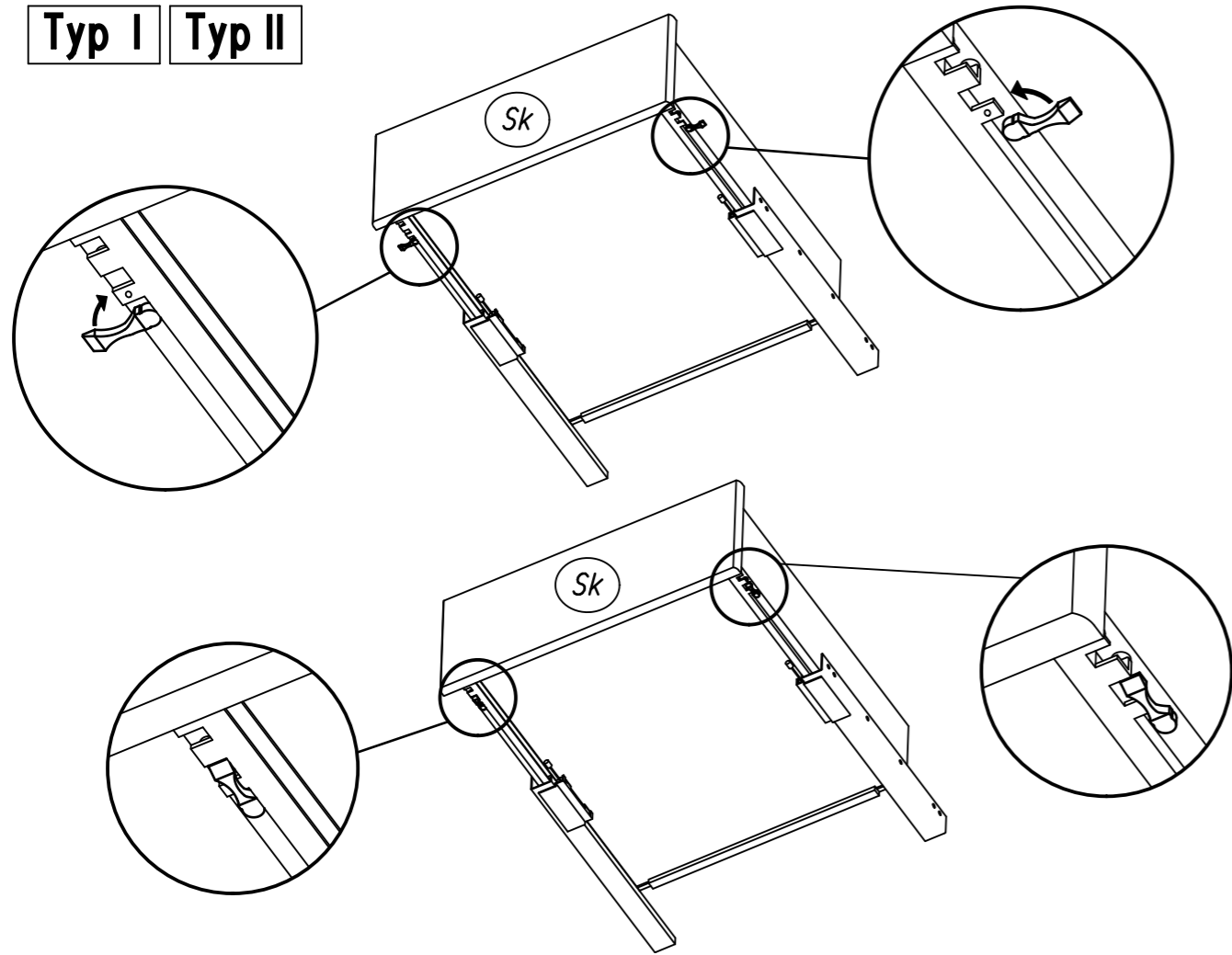

15

6x 565

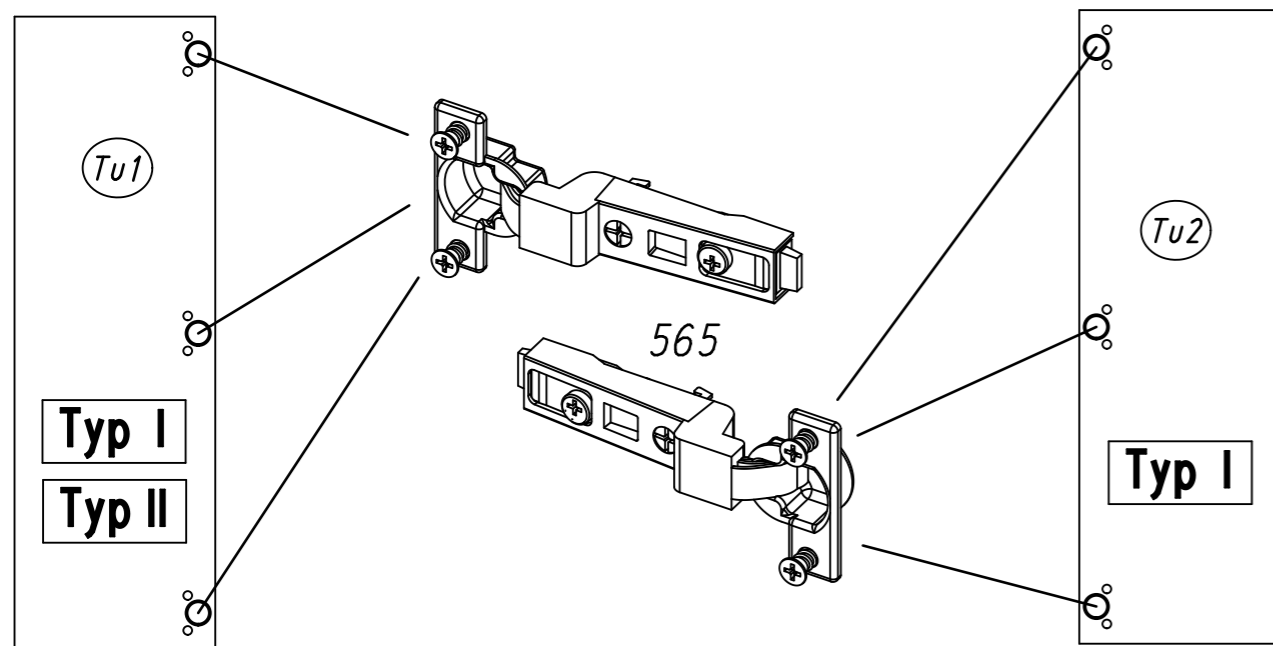
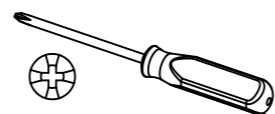
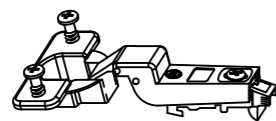

16

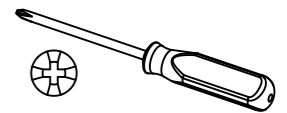

Typ I

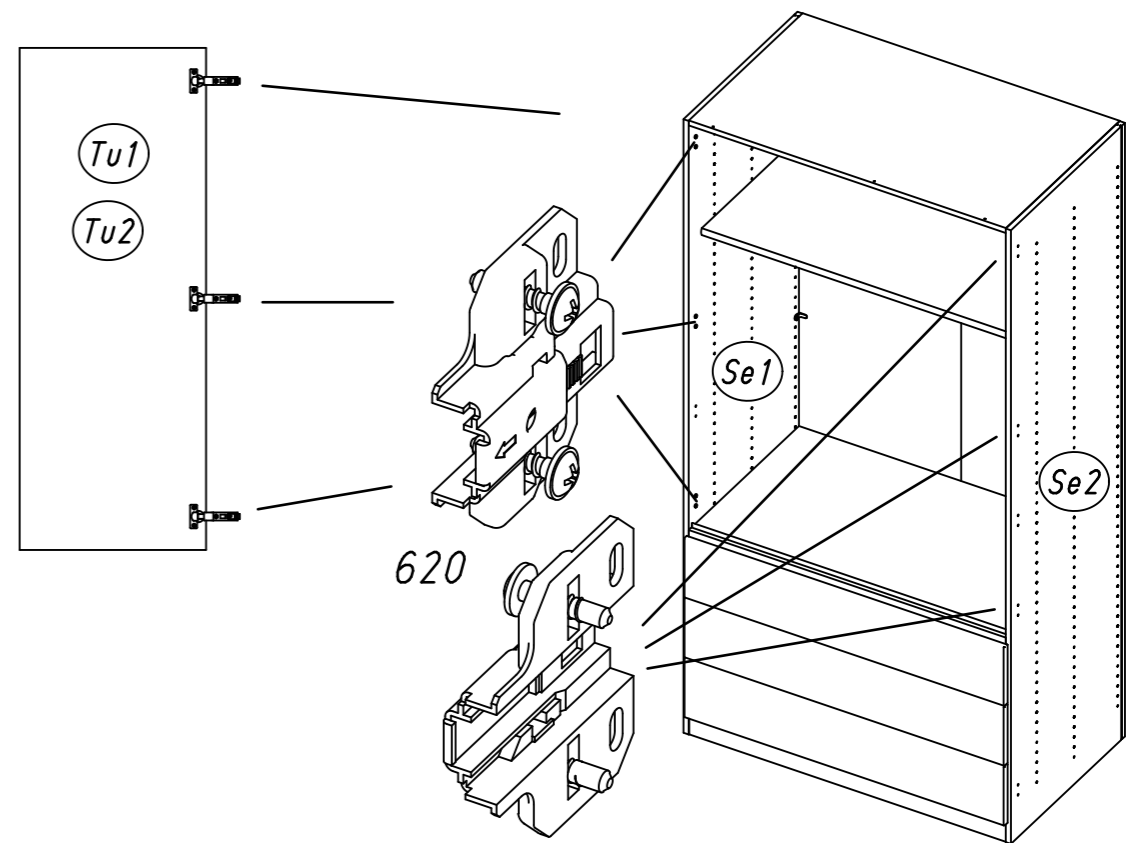

Typ II

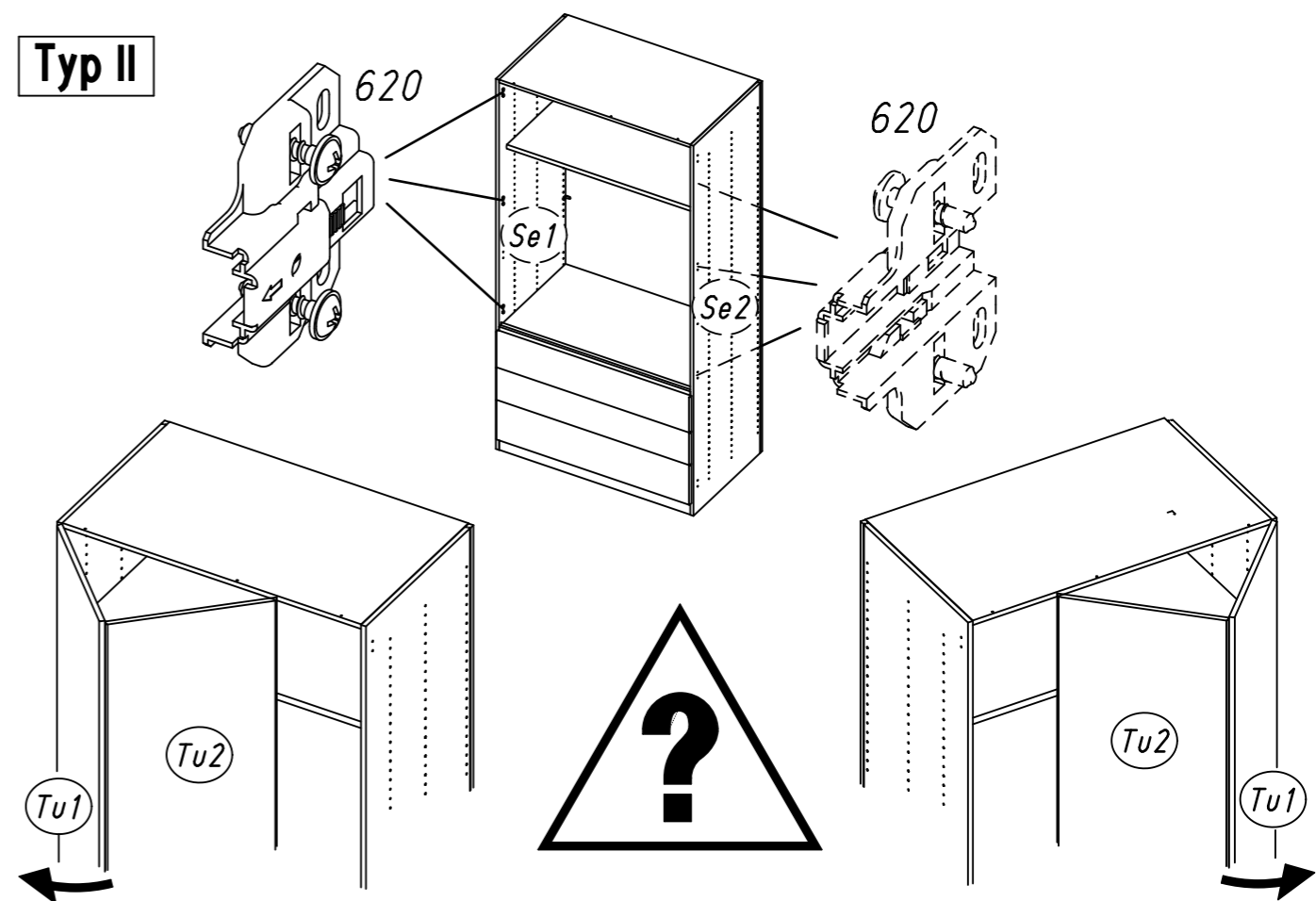

17

6x 620

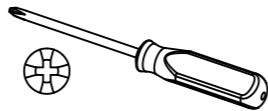
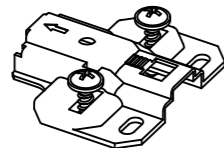

Typ I

Typ II

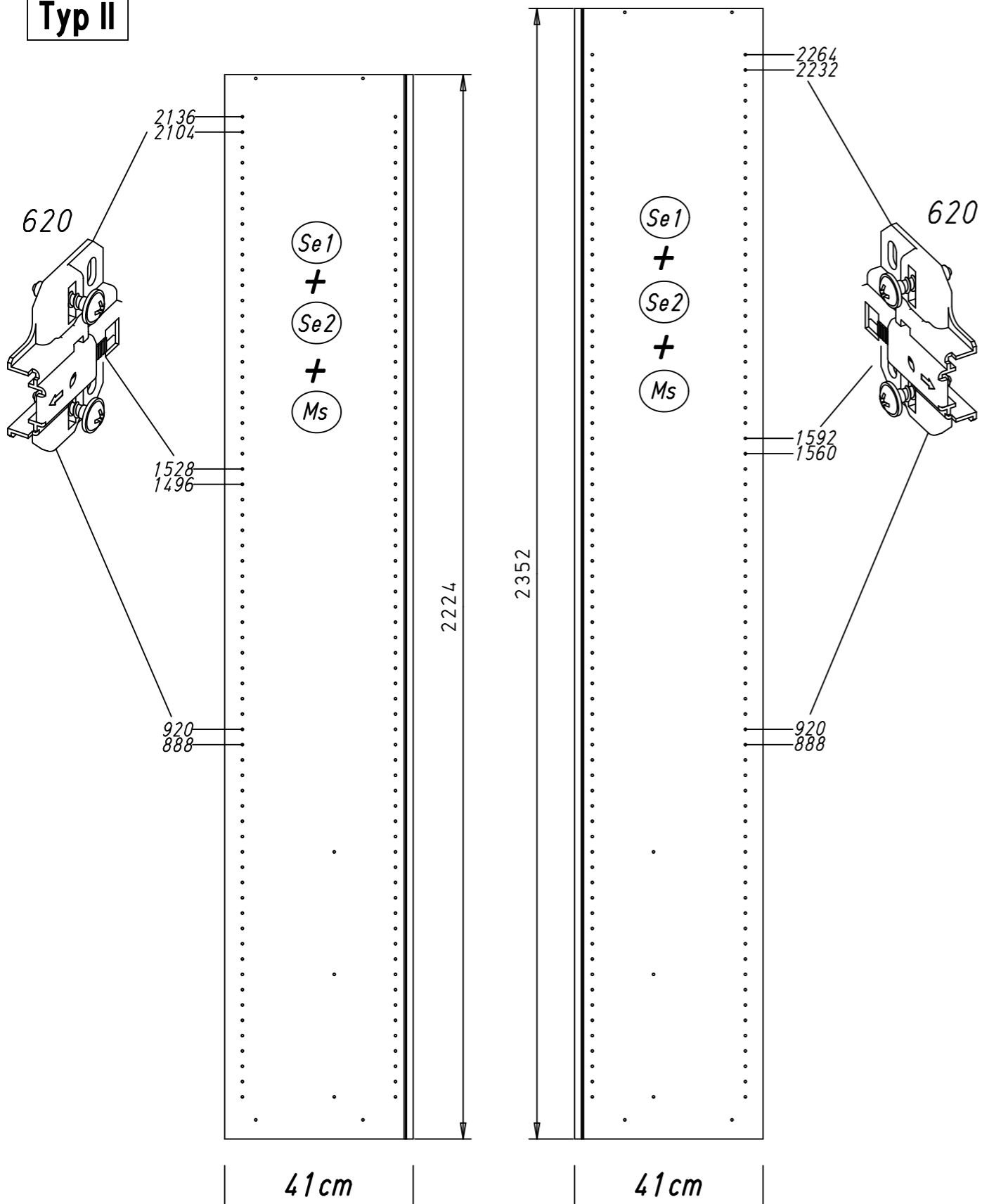

18

8x 179 3x 109 1x 935

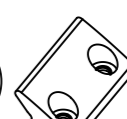
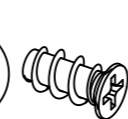

Typ II

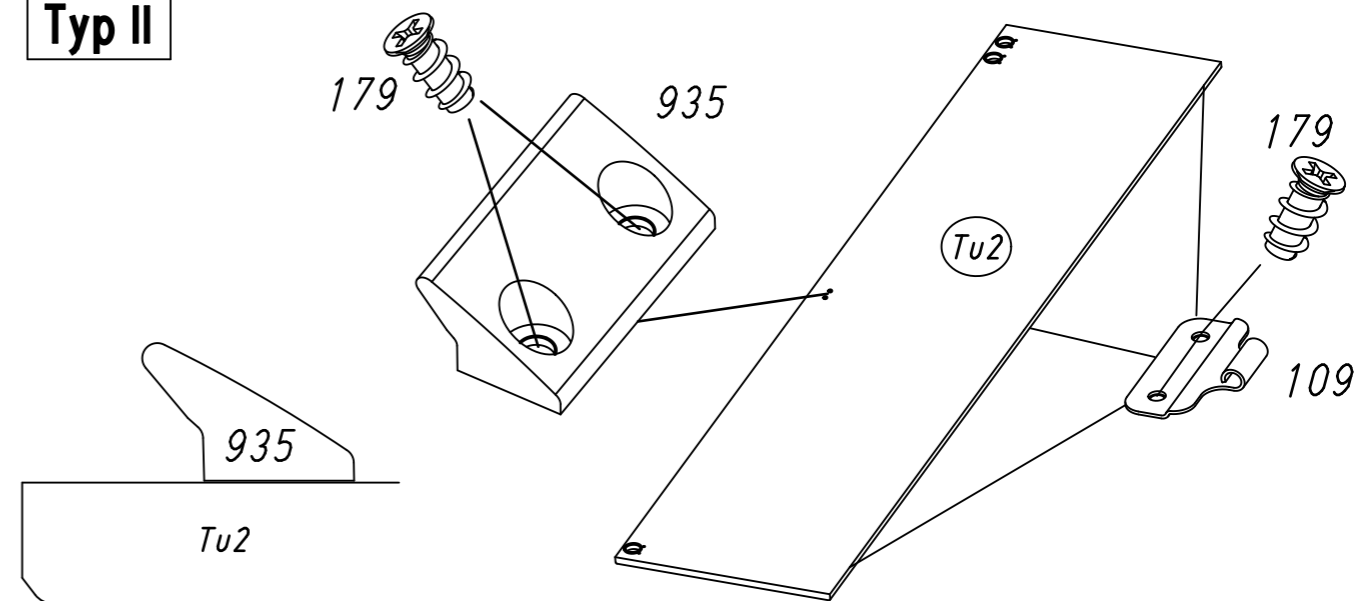

19

1x 205 1x 118/119 1x 812

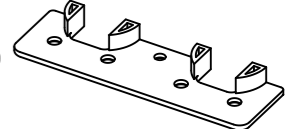
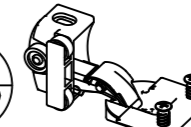
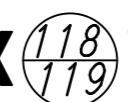
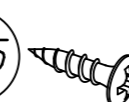

Typ II

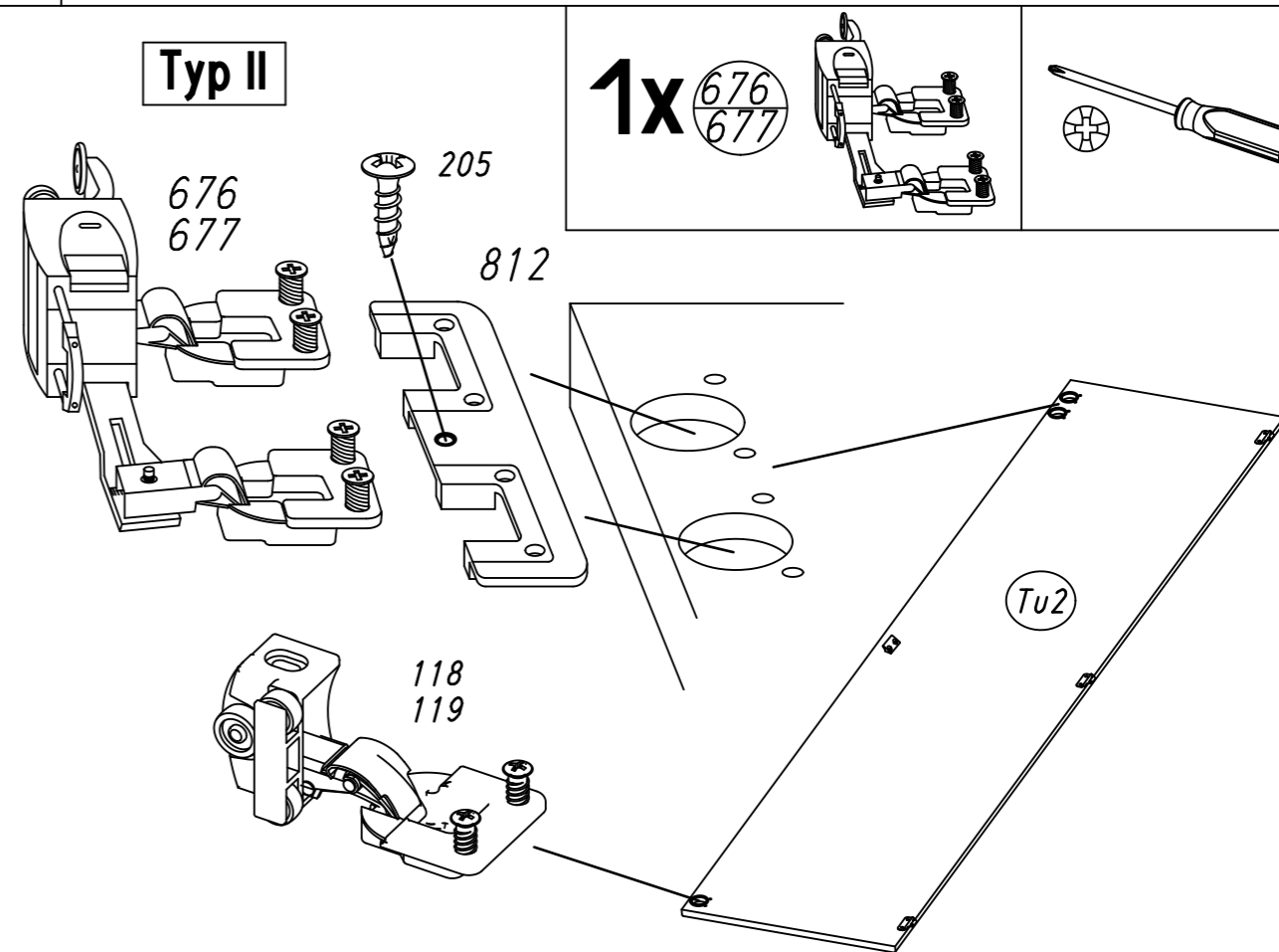

1x 676/677

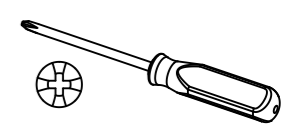

20

3x

110

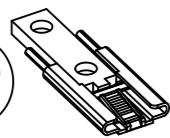

6x

179

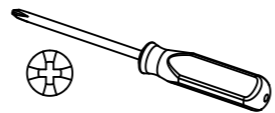
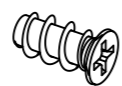

Typ I

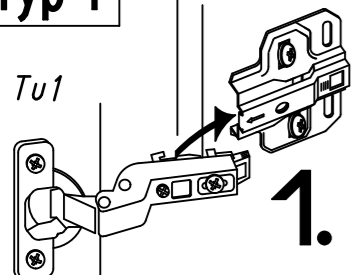

1.

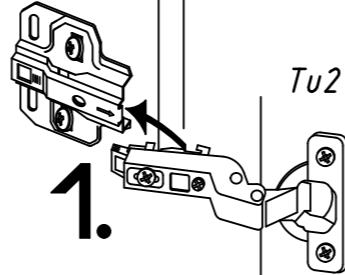
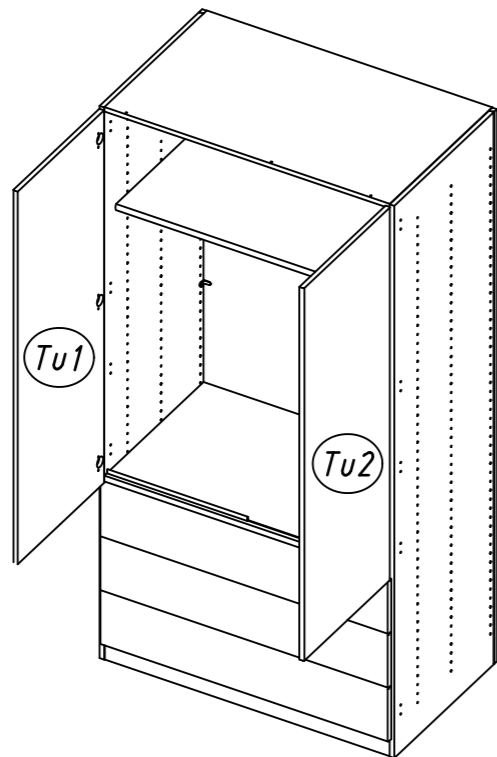

1.

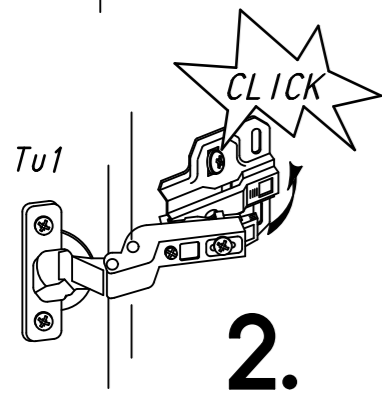

2.

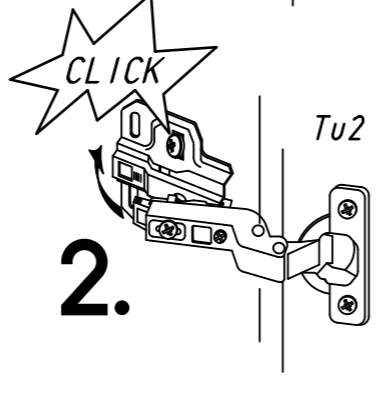

2.

Typ II

179

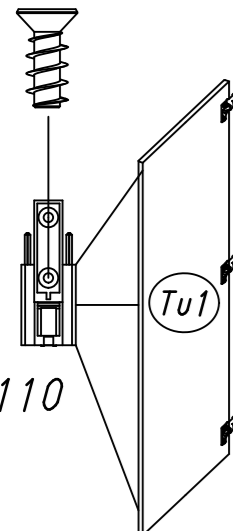

110

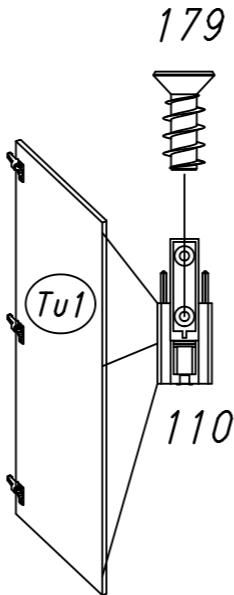
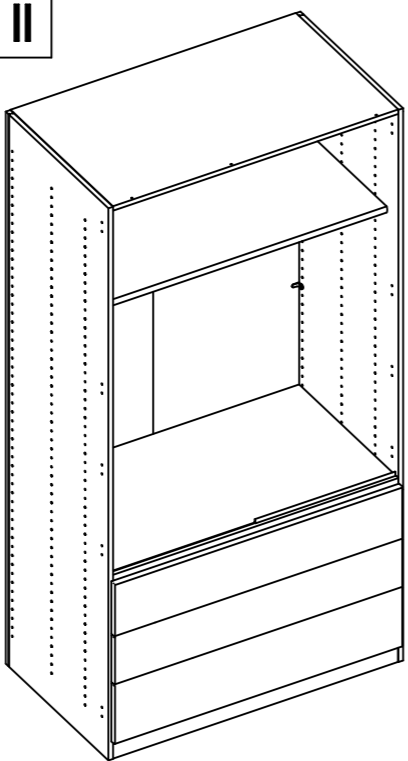
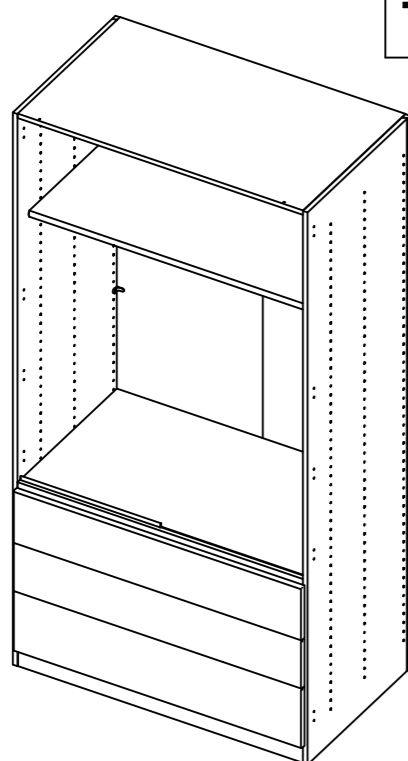

179

110

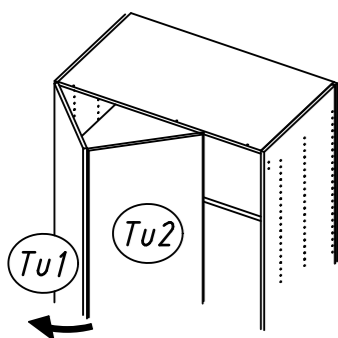

Tu1

Tu2

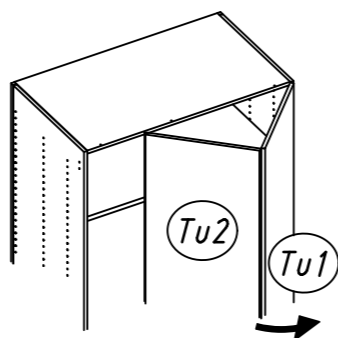
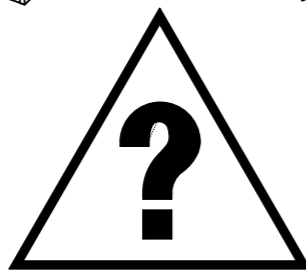

Tu2

Tu1

21

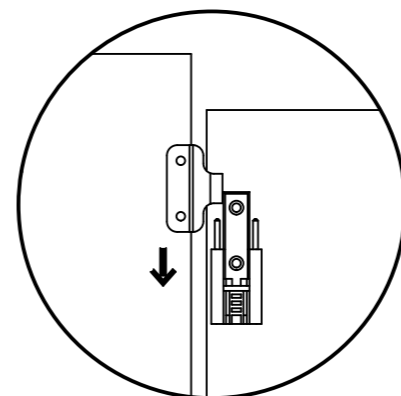
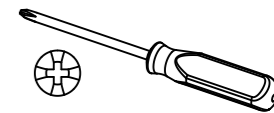

2.

1.

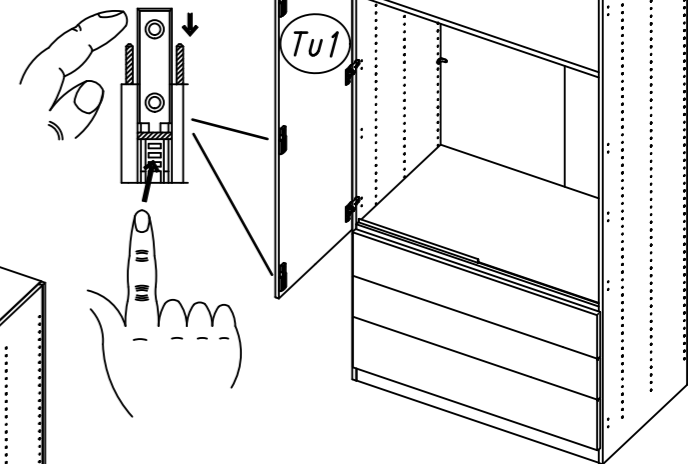

Tu1

3.

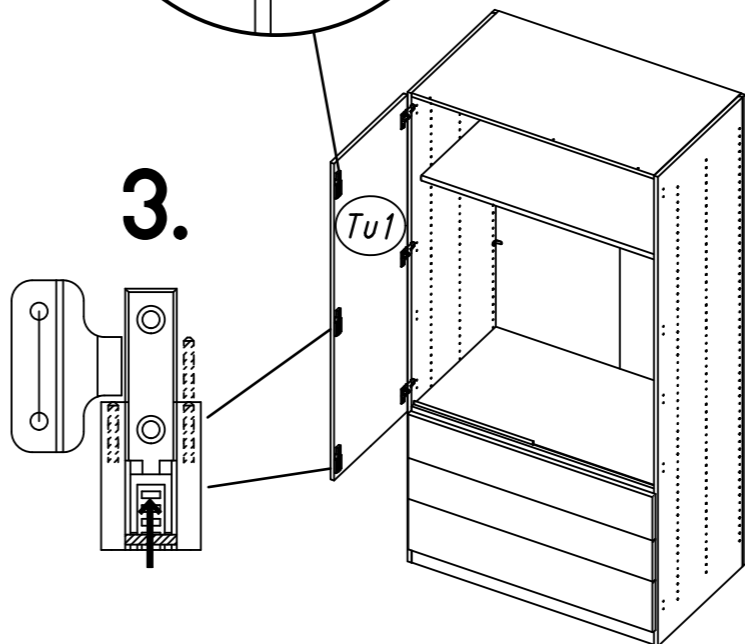

Tu1

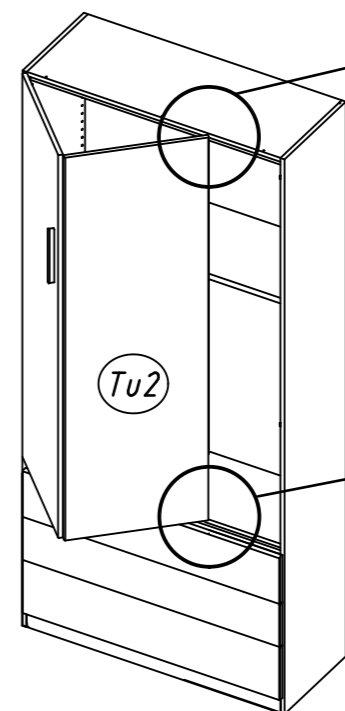

Tu2

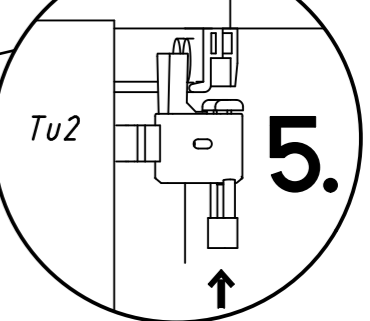

Tu2

5.

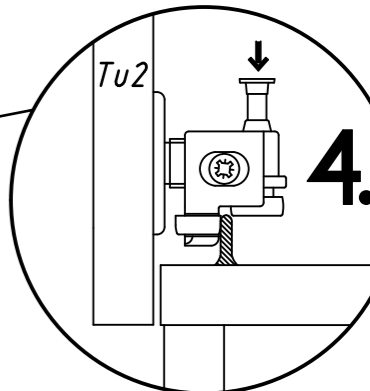

Tu2

4.

Typ I

Typ II

22

2x 201

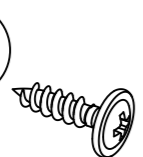

2x 205



1x 934

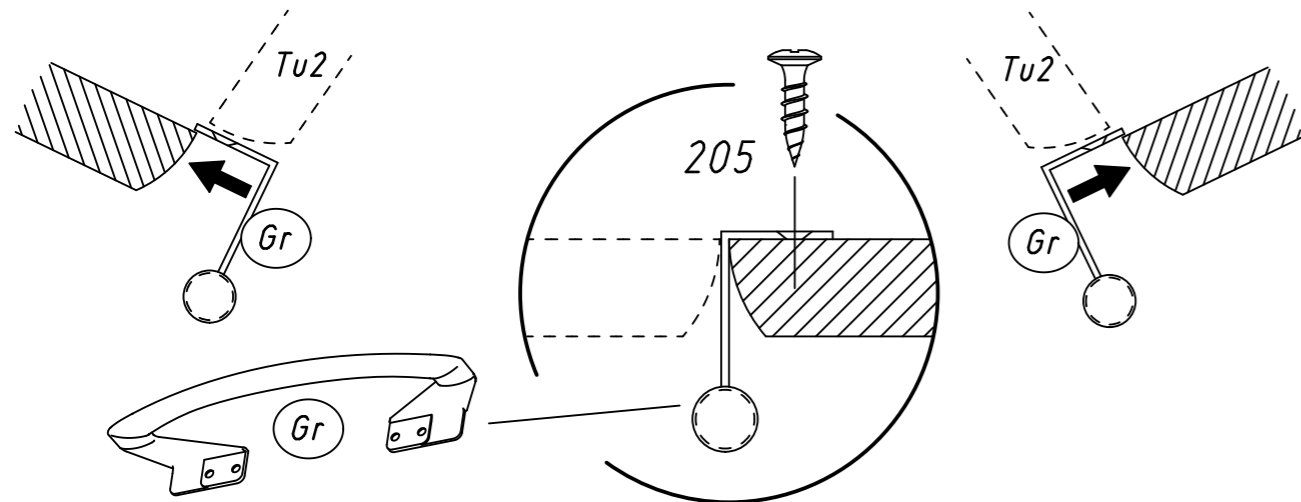
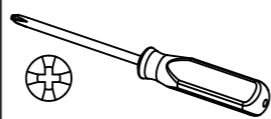

Typ II

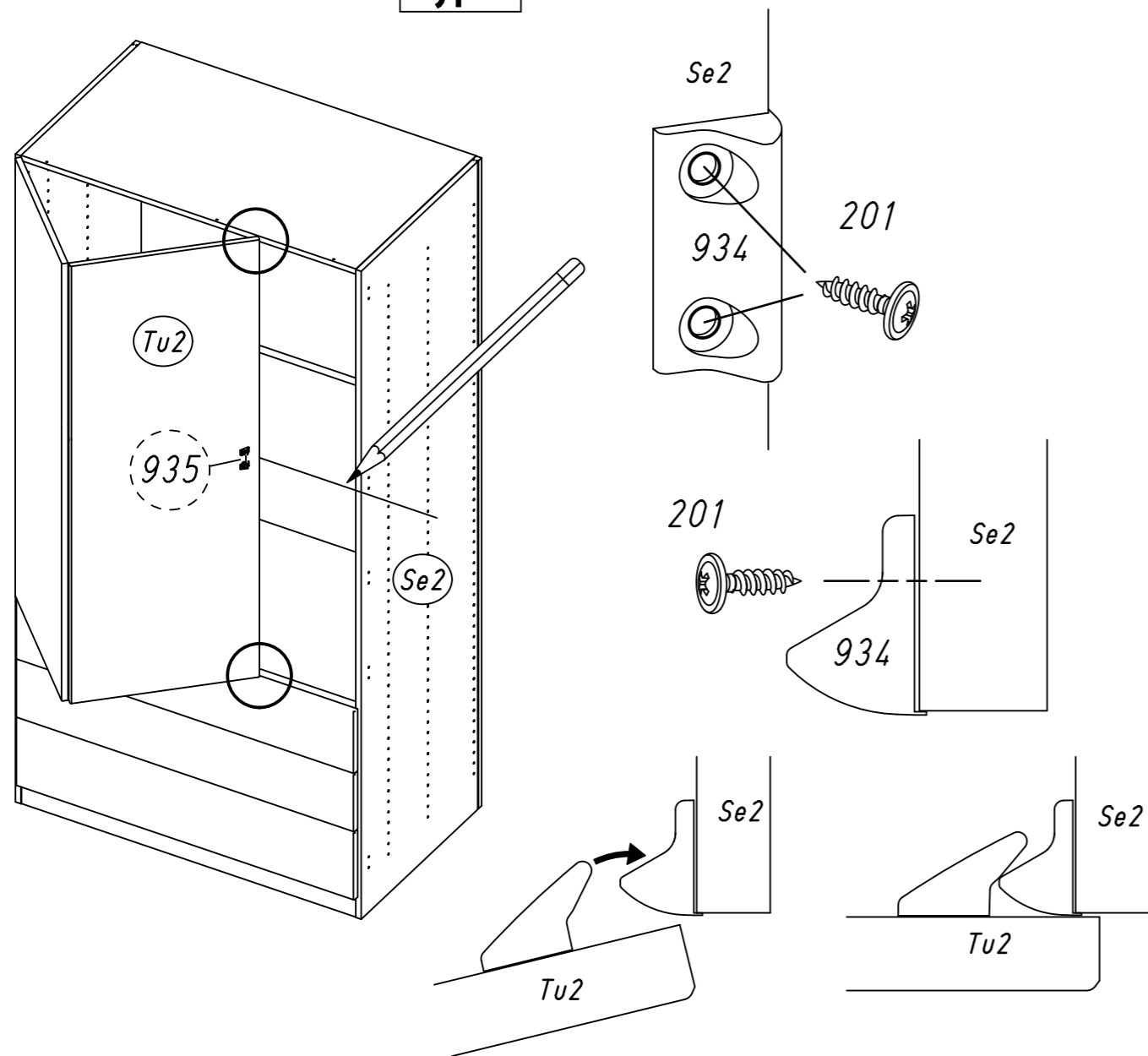

23

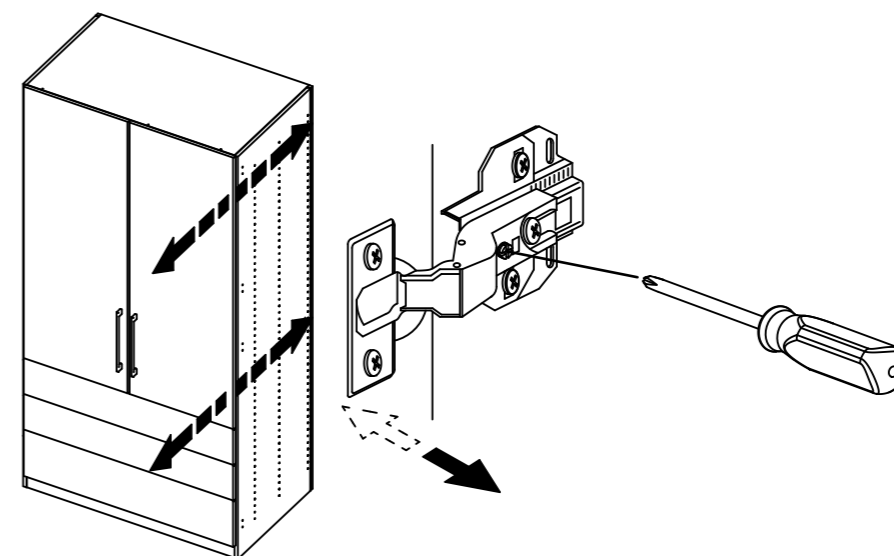
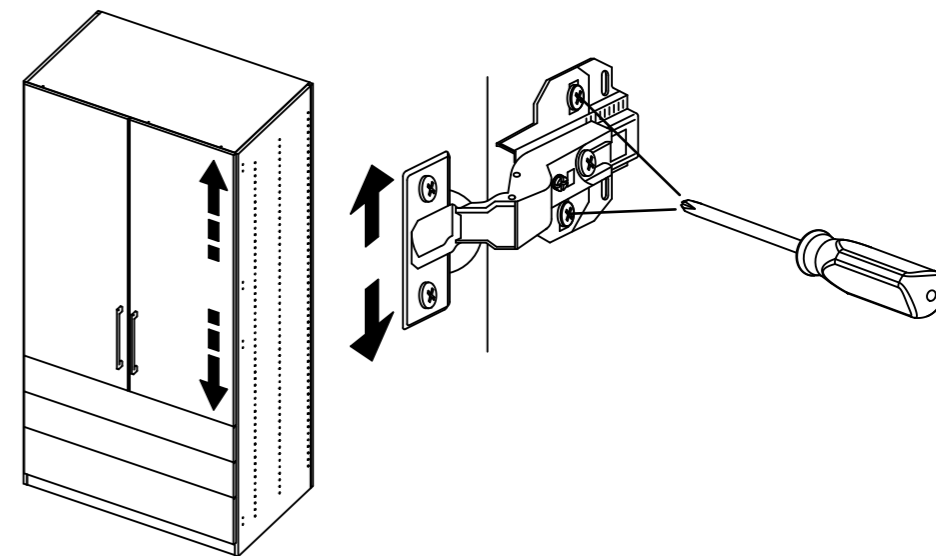
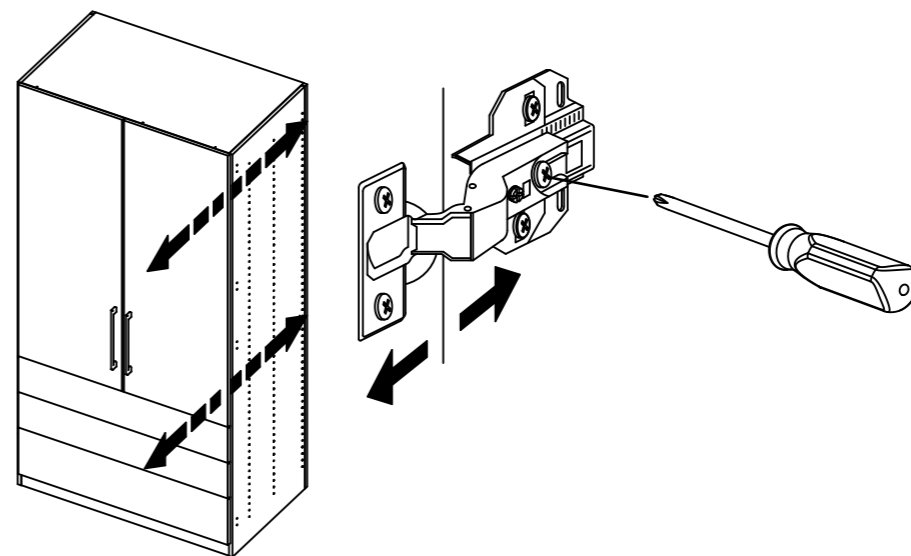
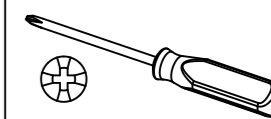

Typ I

Typ II

24

2 x 12

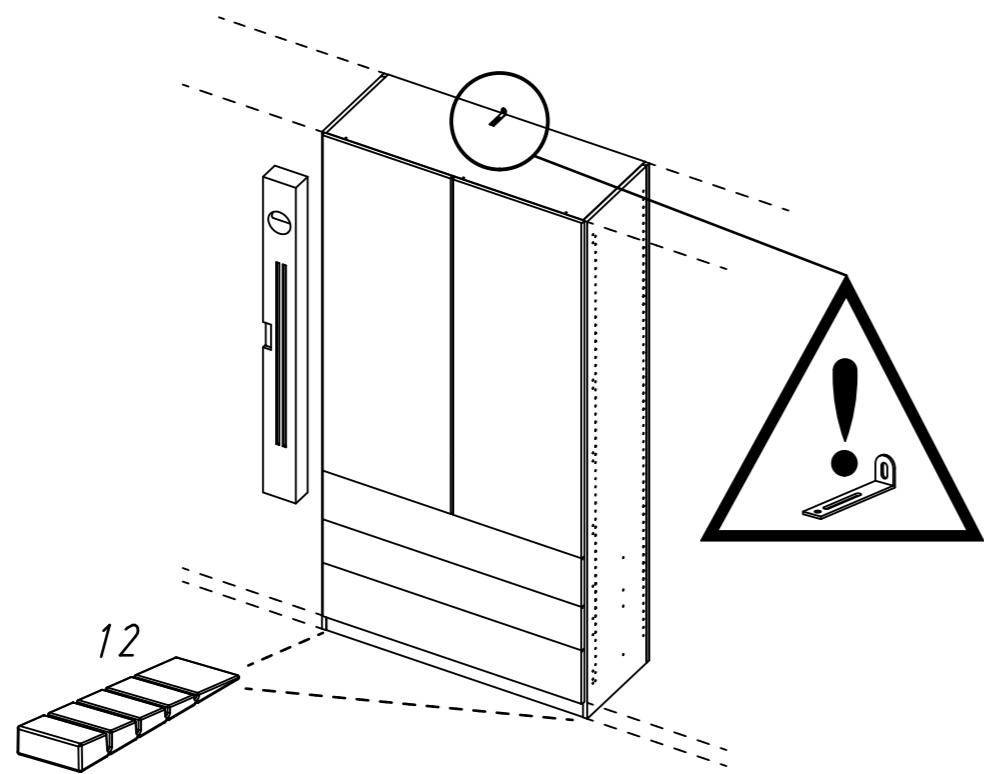
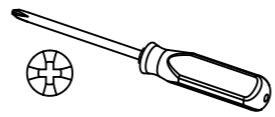
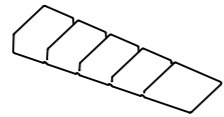

Typ I Typ II

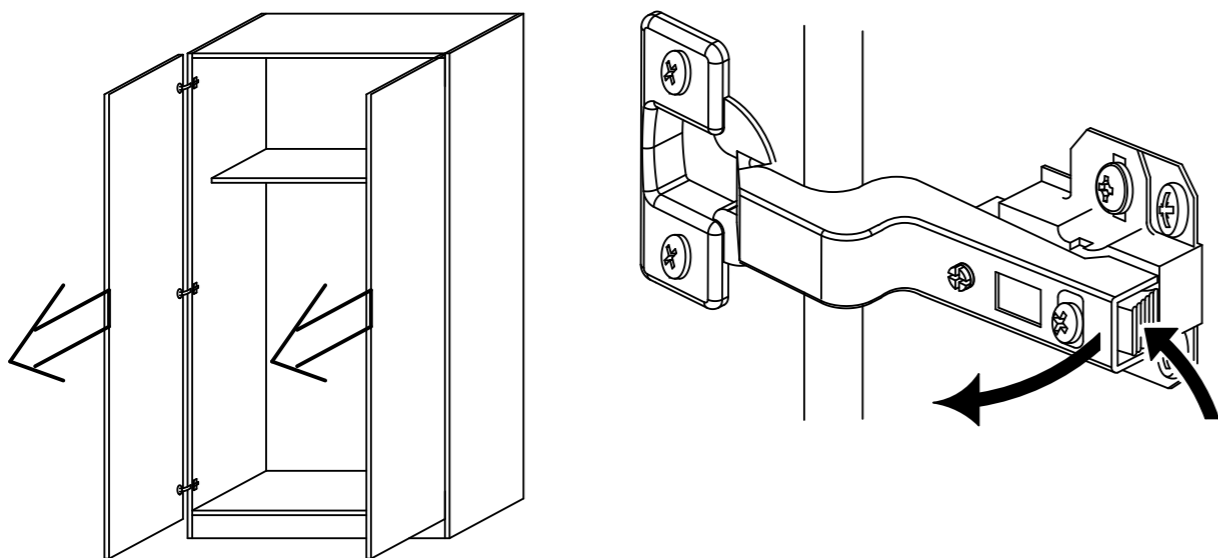

25

12 x 621

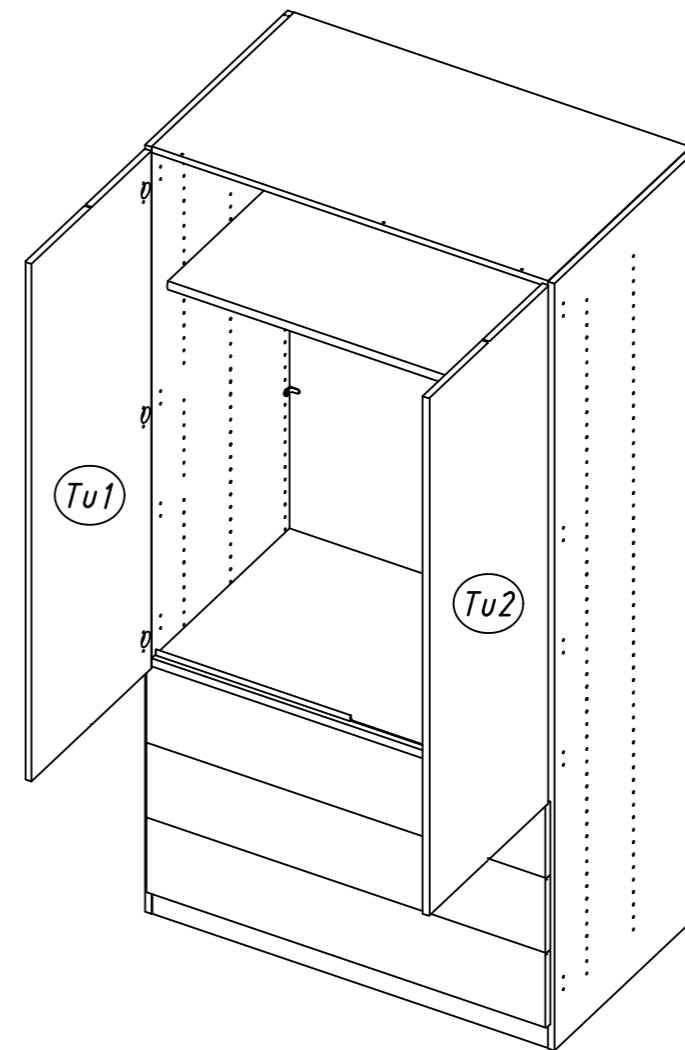
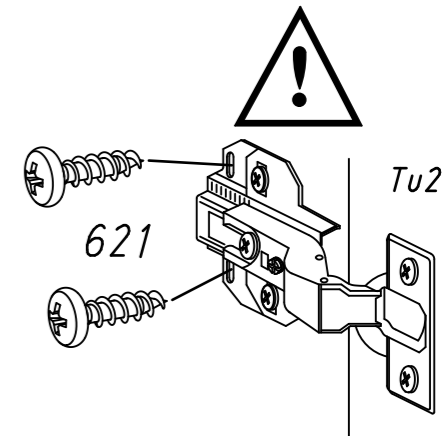
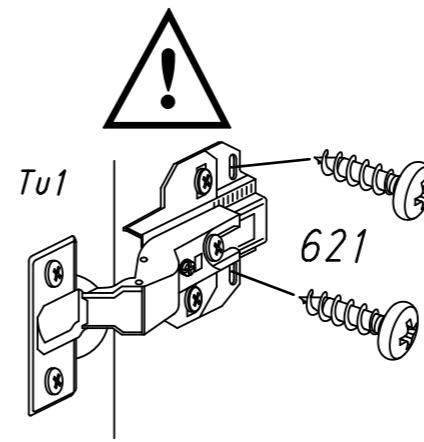
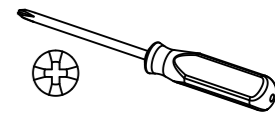
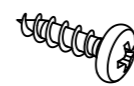

Typ I
Typ II

26

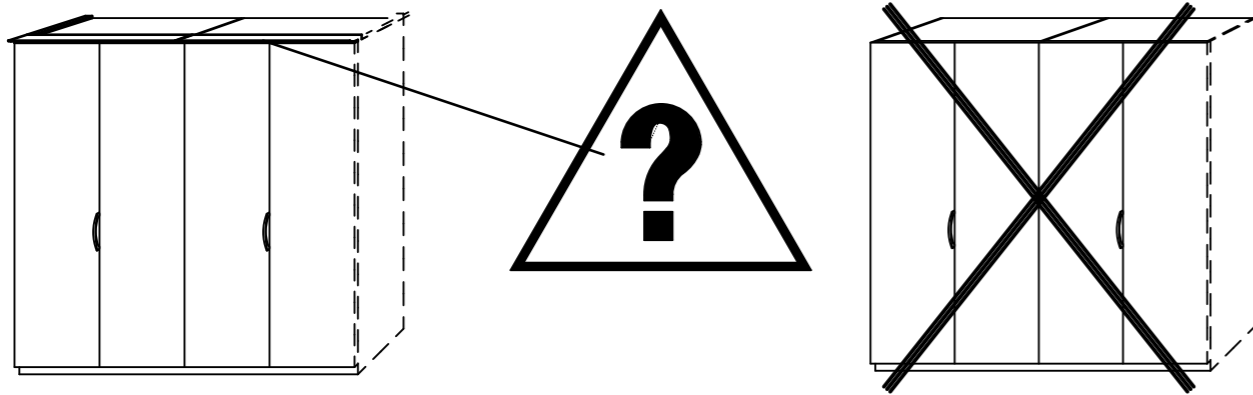

201

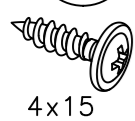

4x15

214

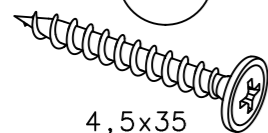

4,5x35

423

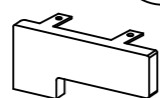

424

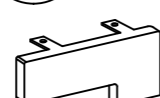

425

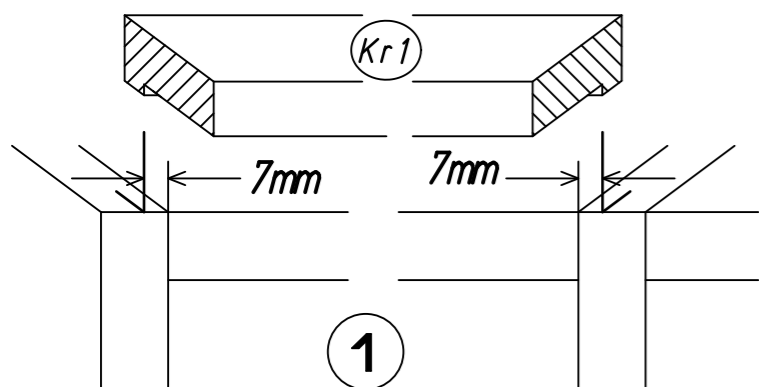
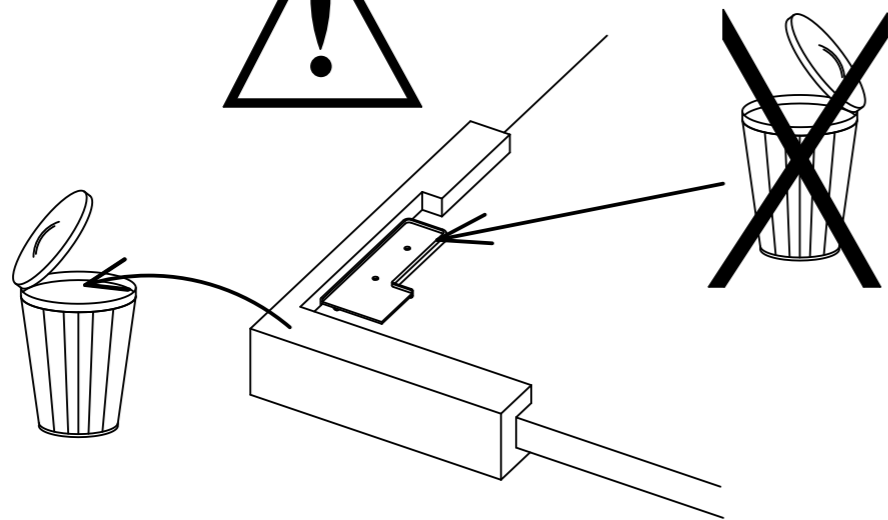
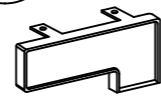

1

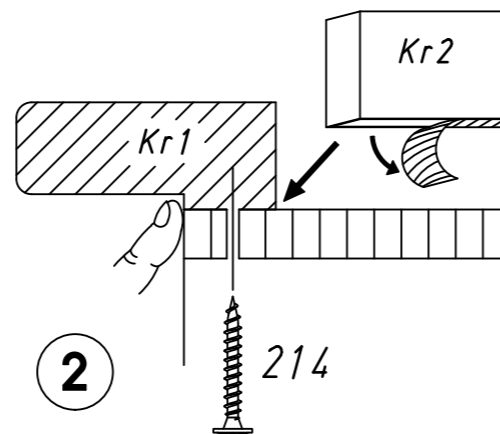

2

27

4 x 201 1 x 423 1 x 425

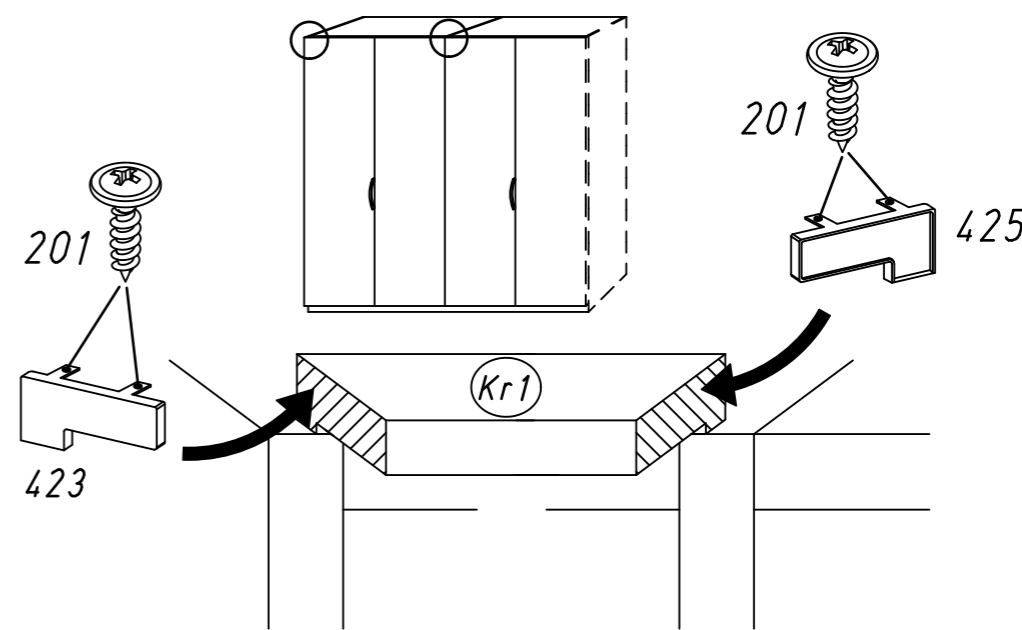

Typ I Typ II

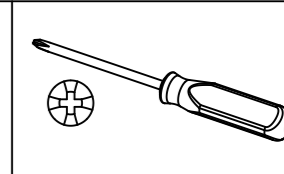
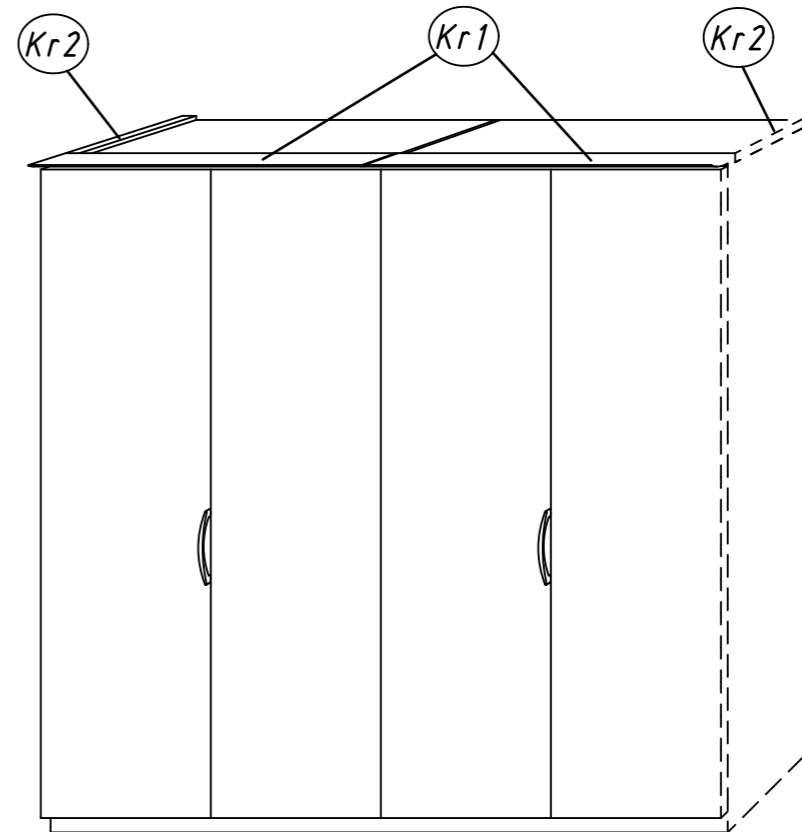

28

1.

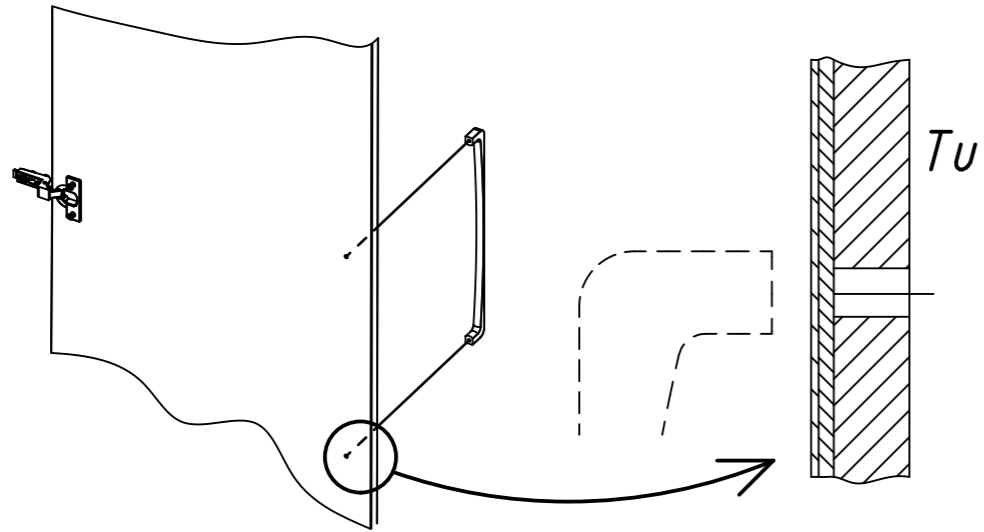

2.

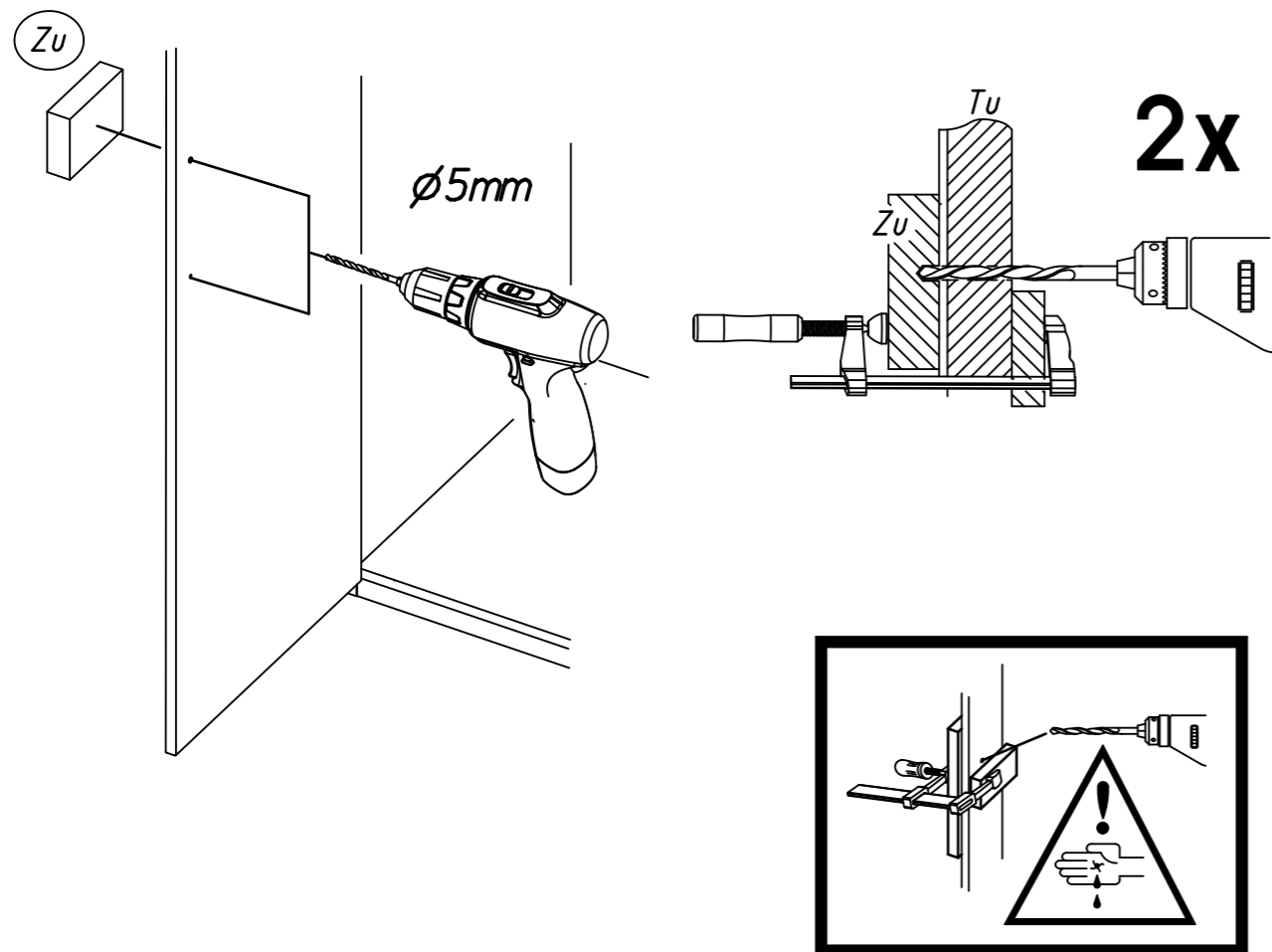

ME 442

rauch

- (A)
- 3,5x15

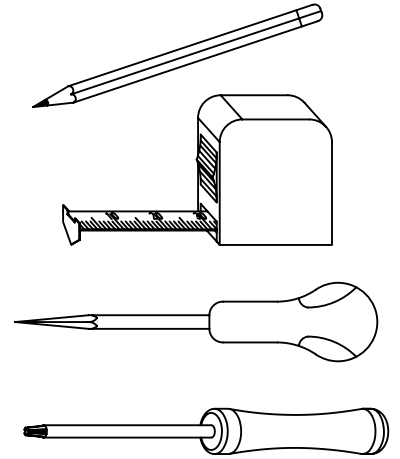
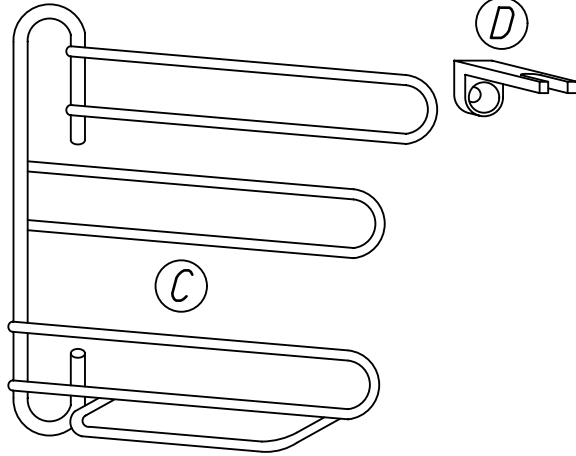
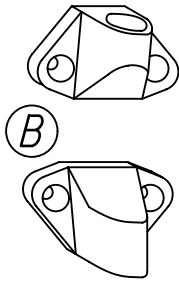

ca. 45mm

1.

127mm

25mm

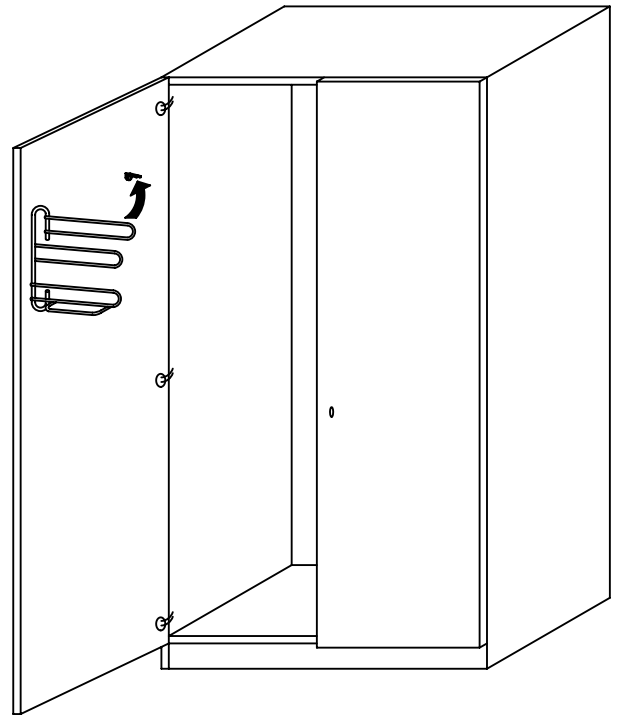
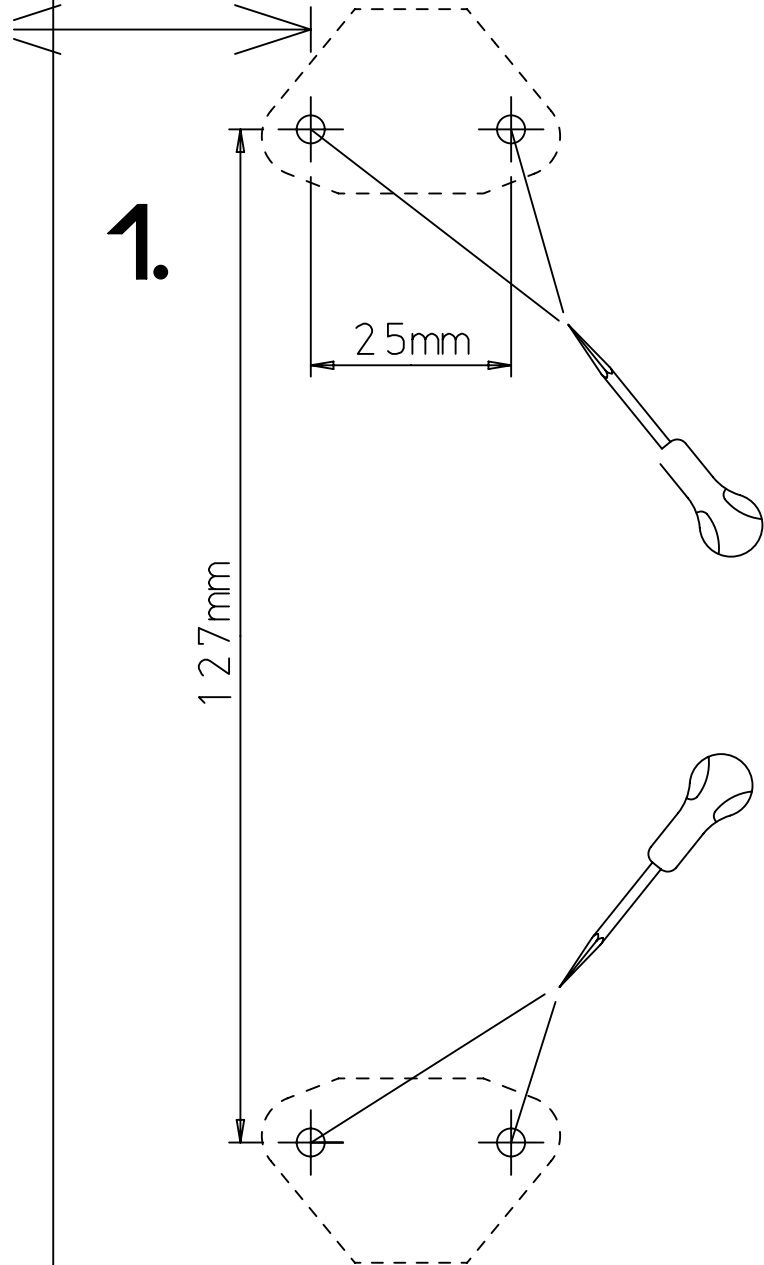

2.

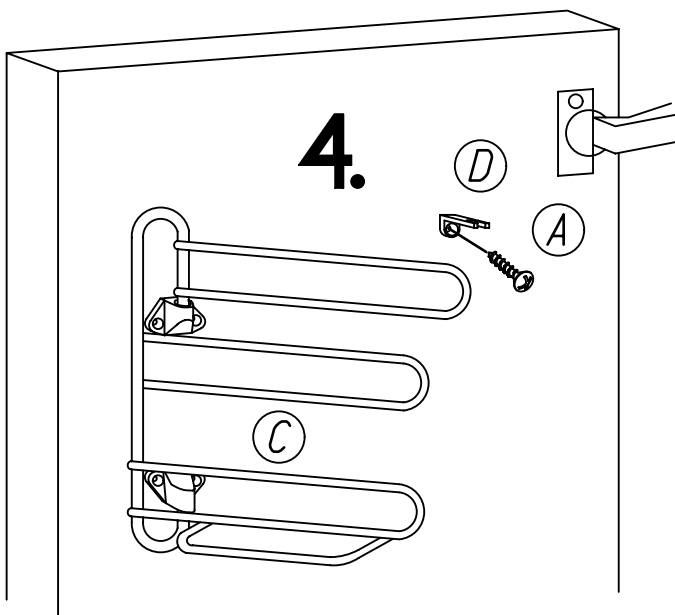
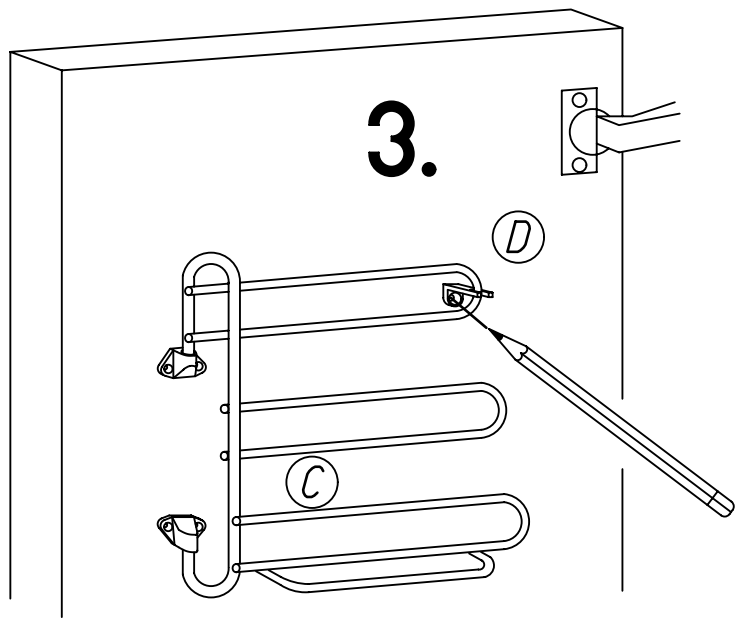
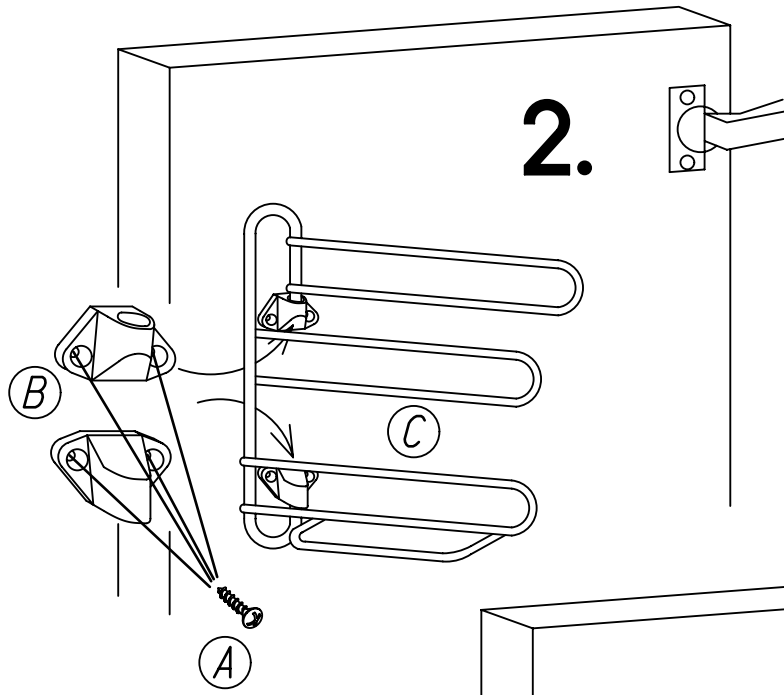

1.

ME632_03

rauch

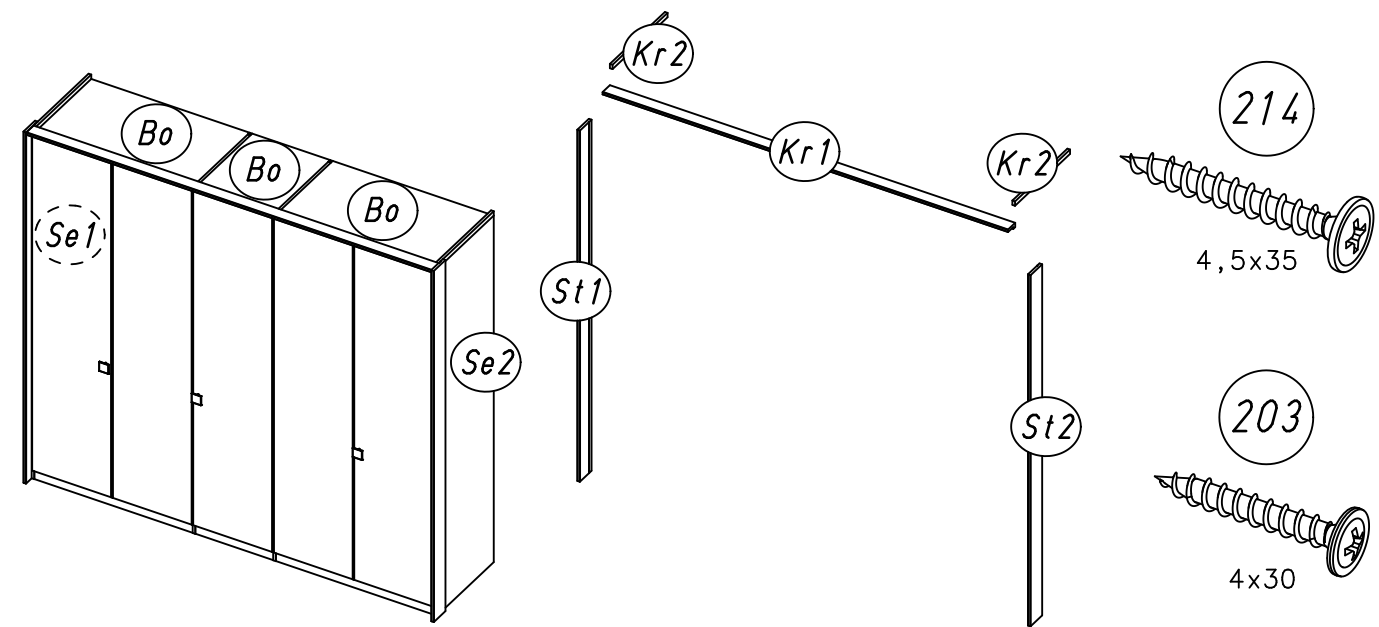
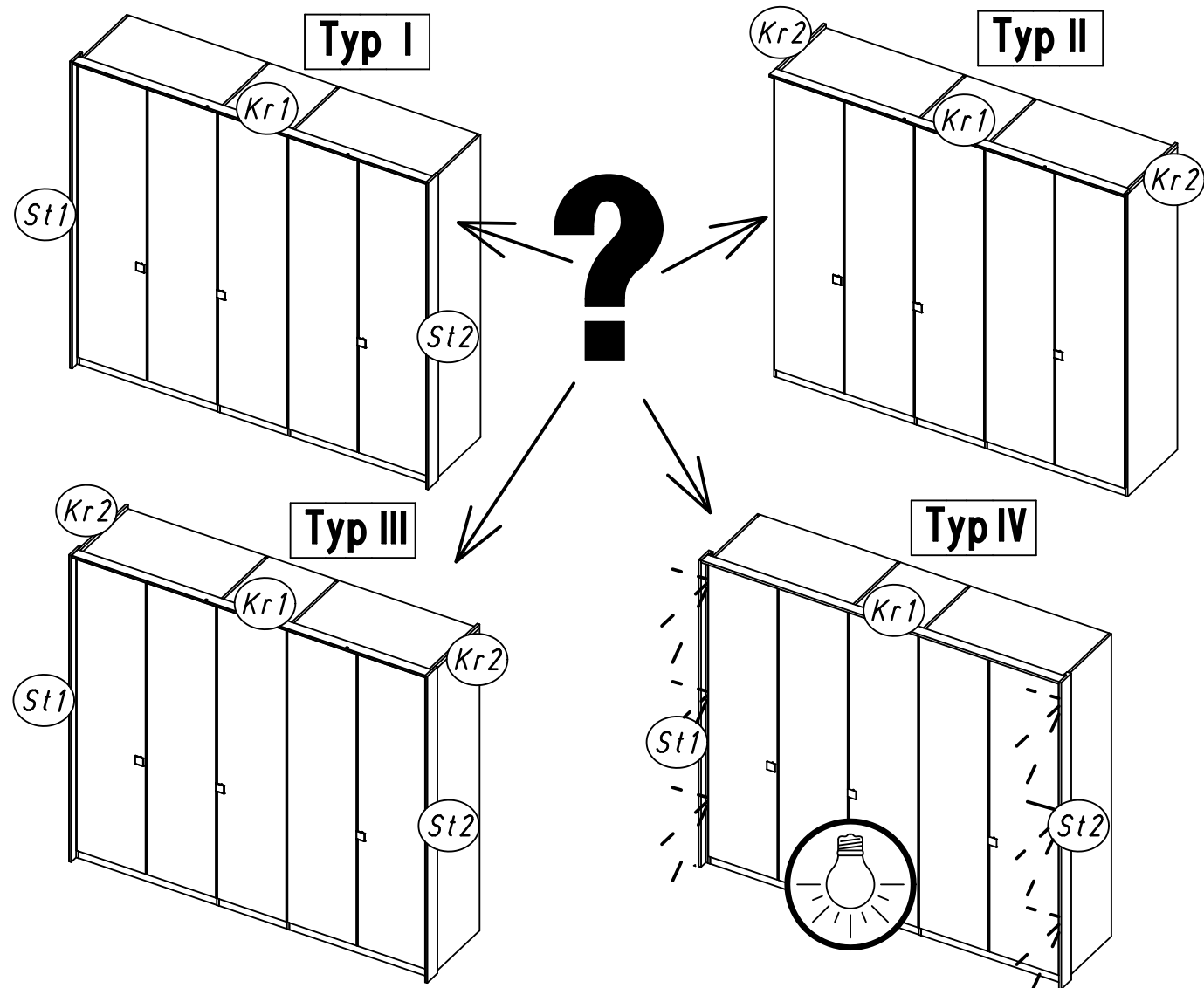

2.

1 214 Typ I Typ II Typ III

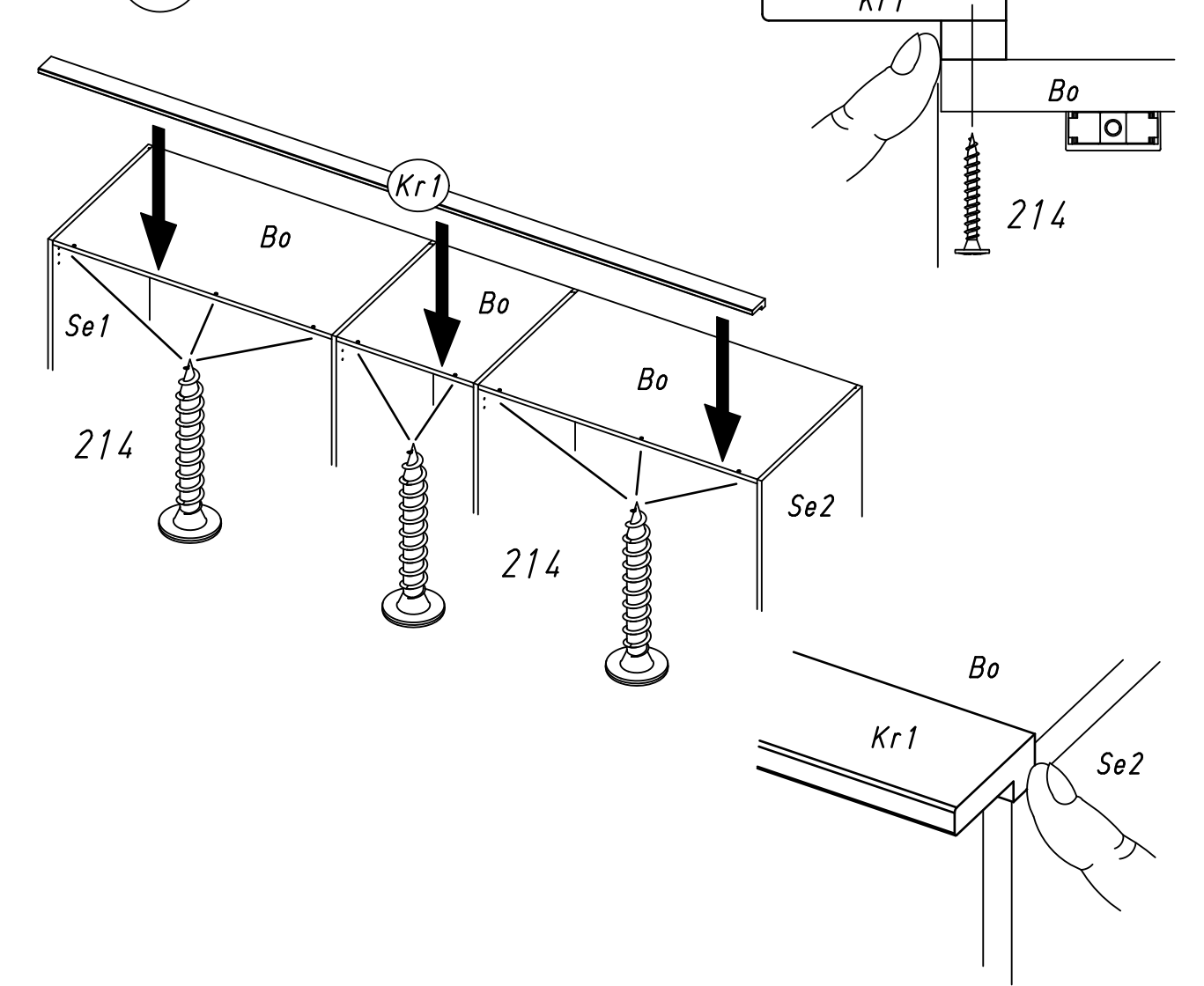

2 Typ II Typ III

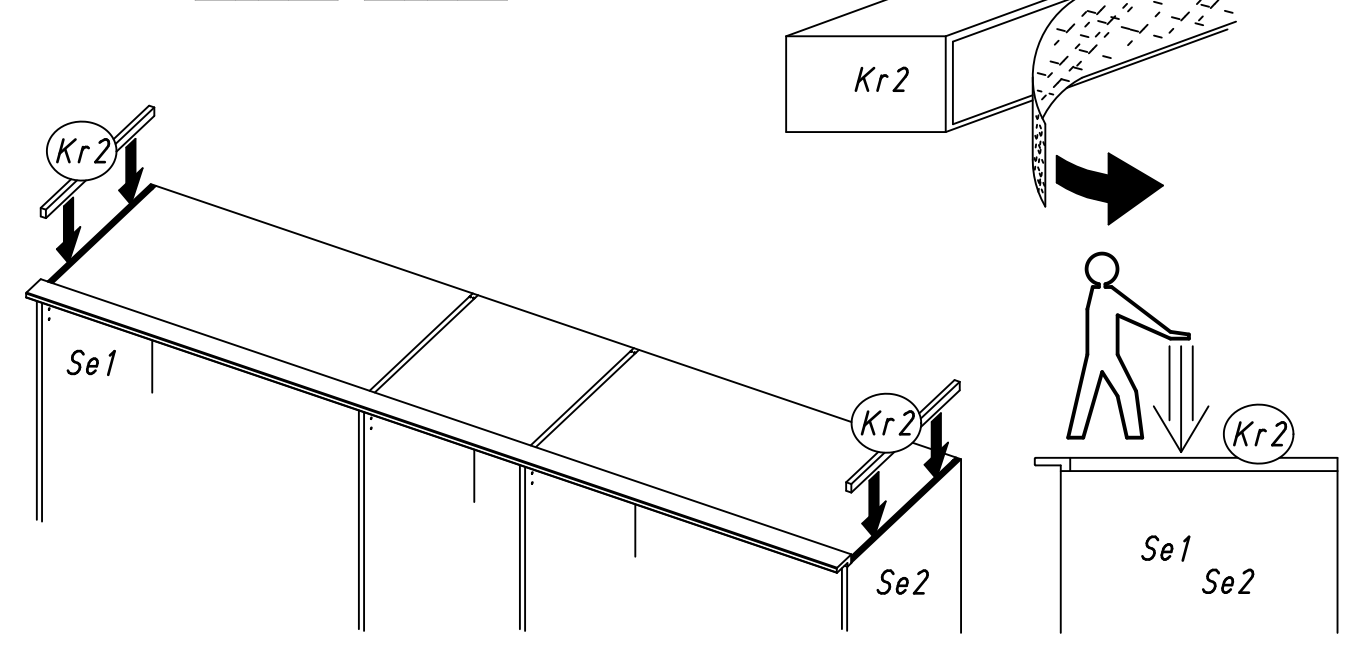

3 203 Typ I Typ III

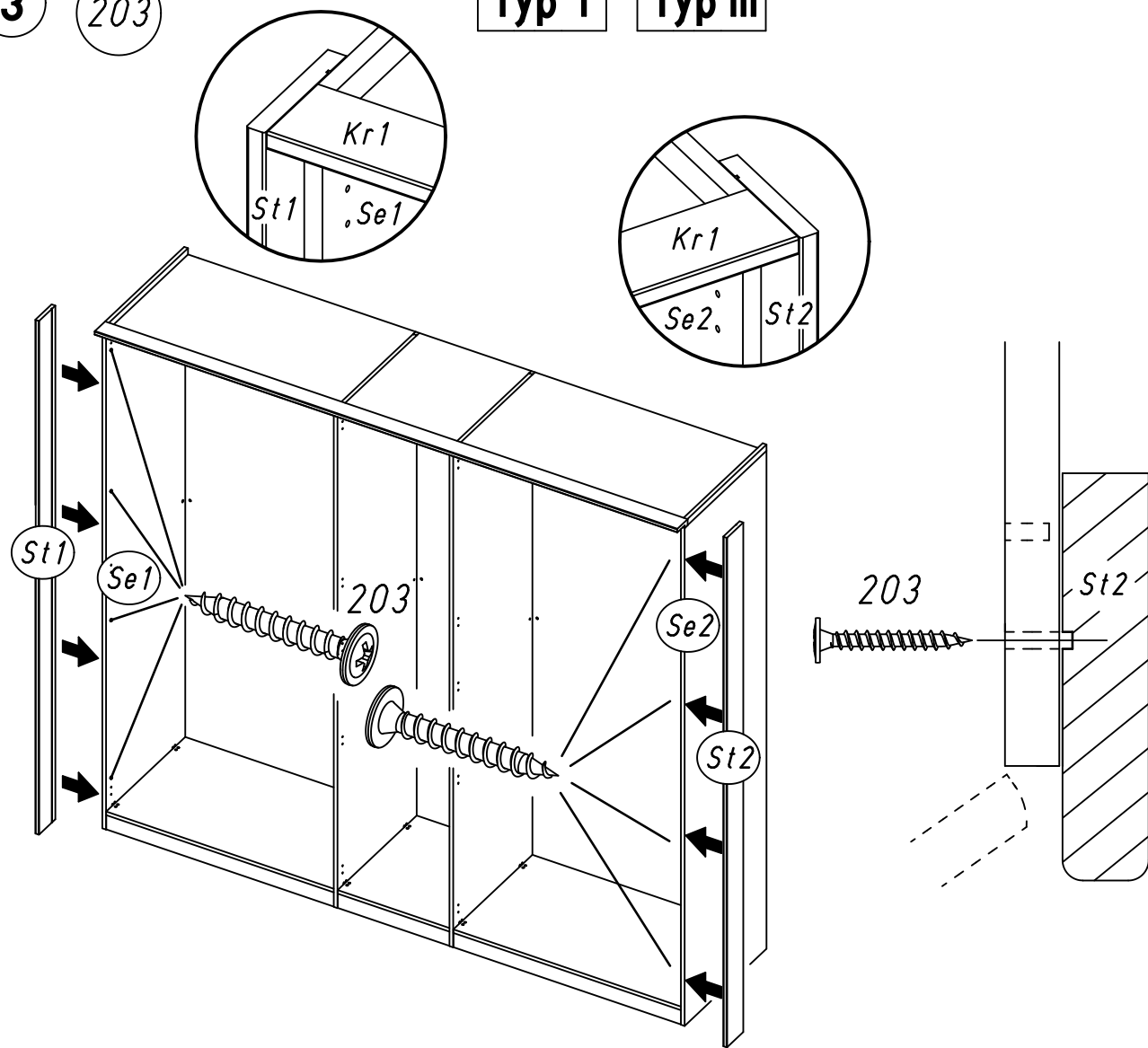

Typ I Typ II Typ III

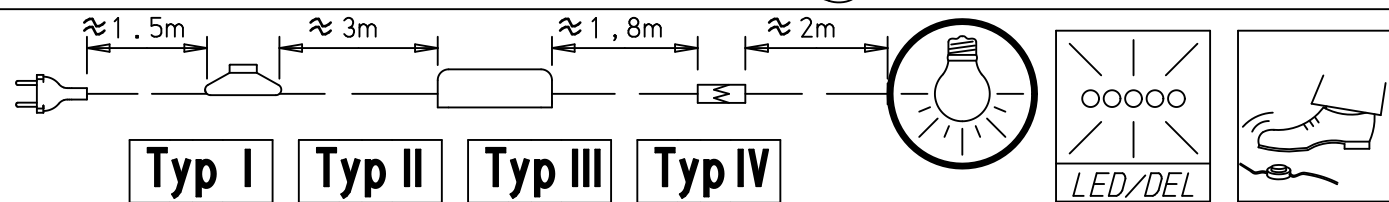
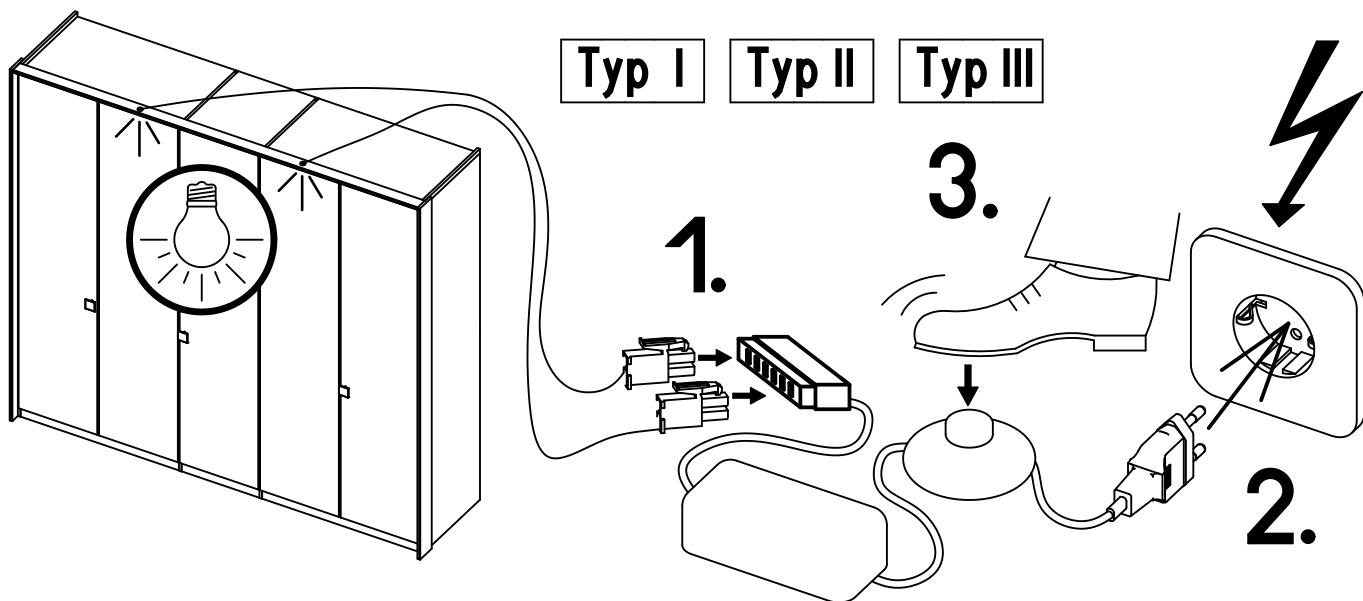

Typ I Typ II Typ III Typ IV

Typ IV

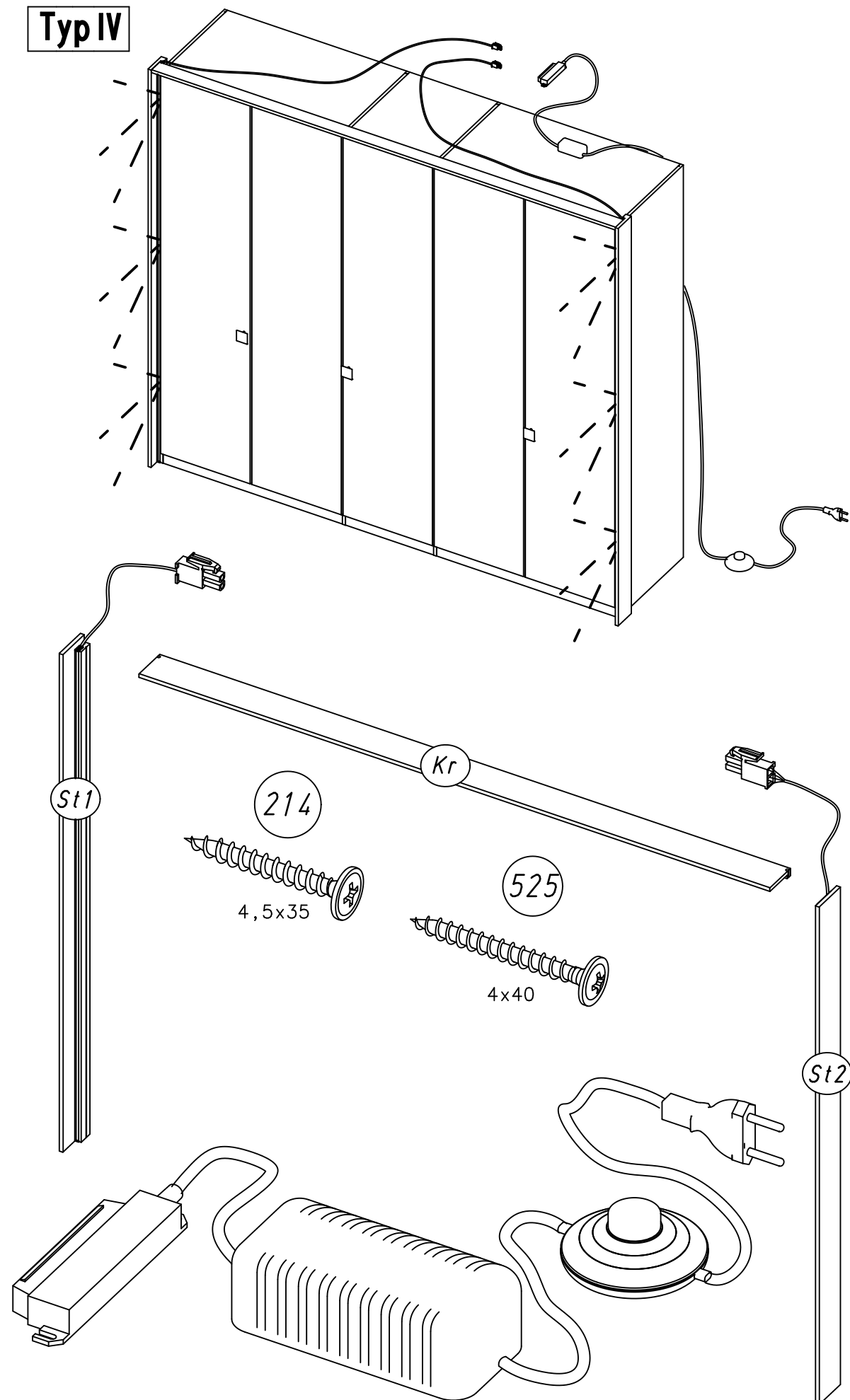

214

4,5x35

525

4x40

1 525

Typ IV

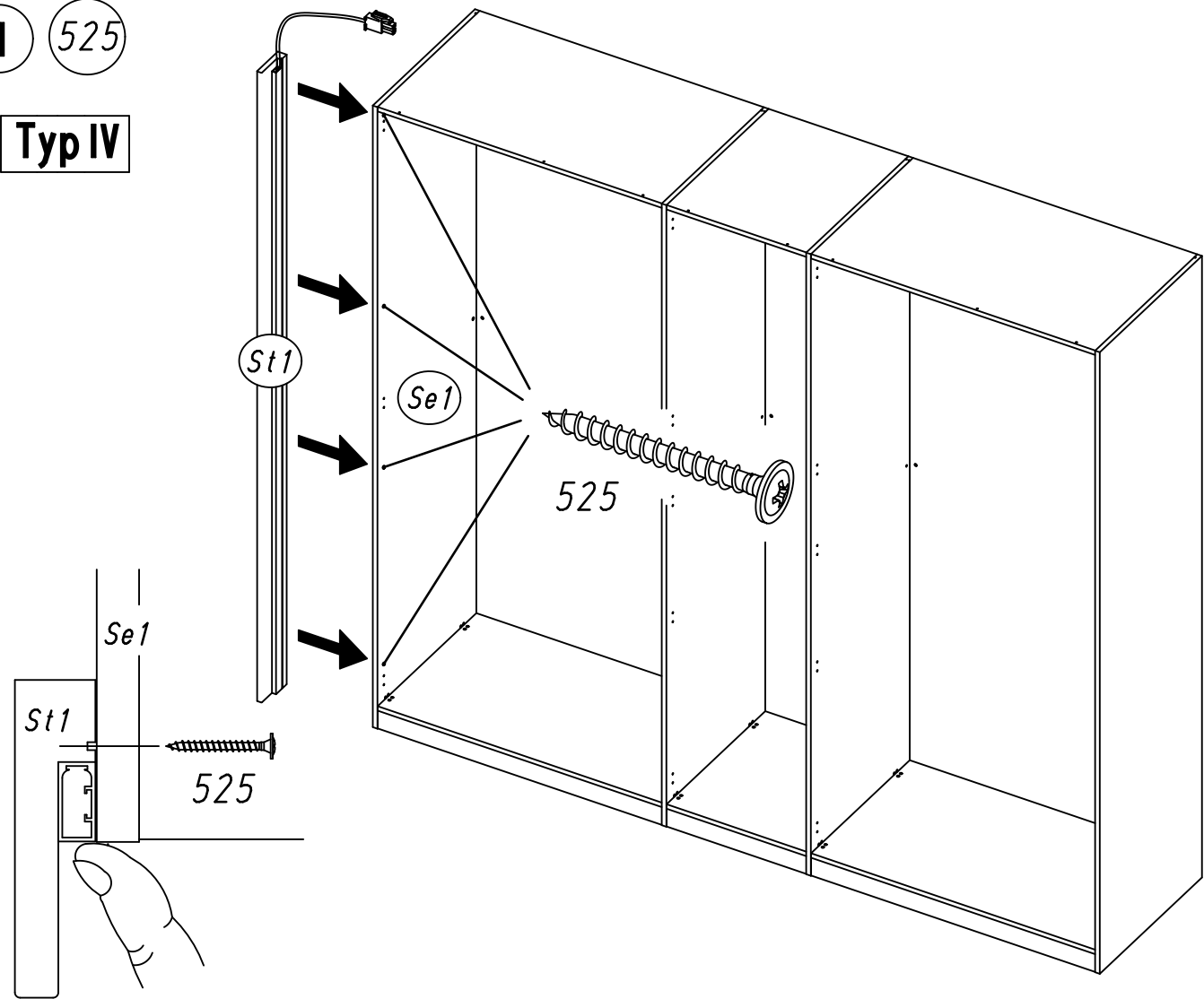

2 214

Typ IV

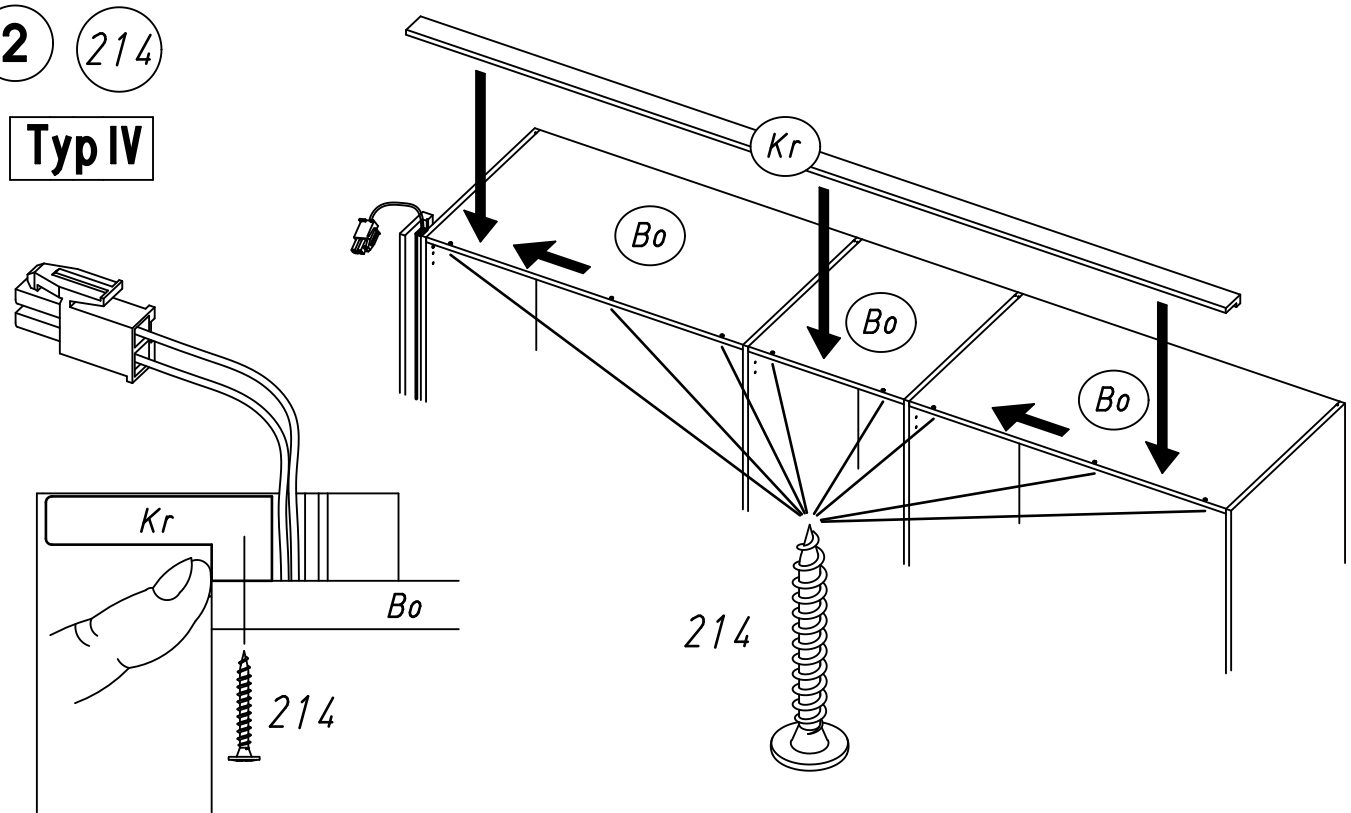

3 525

Typ IV

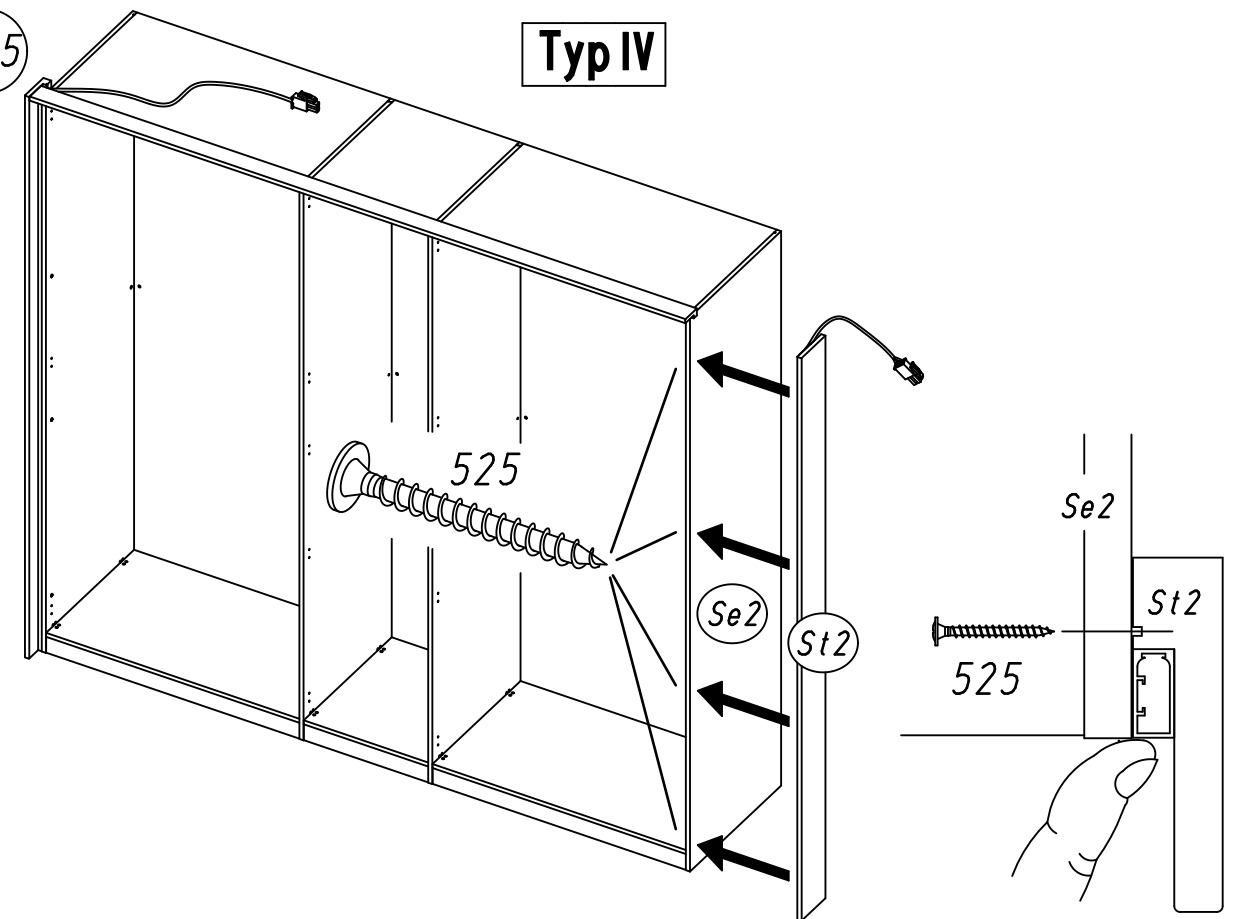

4

Typ IV

