

Art. Nr. 3742 9367

LKZ 41164

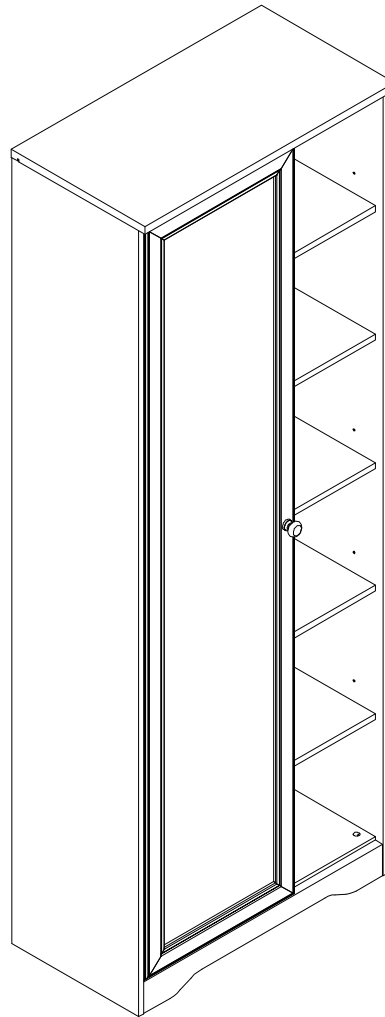

- |   |                                     |
|---|-------------------------------------|
| <b>(D)</b> Montageanleitung             | <b>(GB)</b> Assembly instructions   |
| <b>(FR)</b> Notice de montage           | <b>(IT)</b> Istruzioni di montaggio |
| <b>(NL)</b> Handleiding voor de montage | <b>(PL)</b> Instrukcja montazu      |
| <b>(CZ)</b> Montážni návod              | <b>(SK)</b> Návod na montáž         |
| <b>(HU)</b> Szerelési útmutató          | <b>(RO)</b> Instrukțiuni de montaj  |
| <b>(TR)</b> Montaj talimati             | <b>(RU)</b> Инструкция по монтажу   |

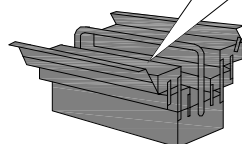
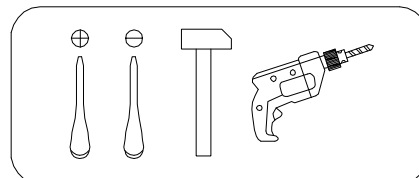
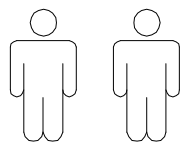

0  
10  
20  
30  
40  
50  
60  
70  
80  
90  
100

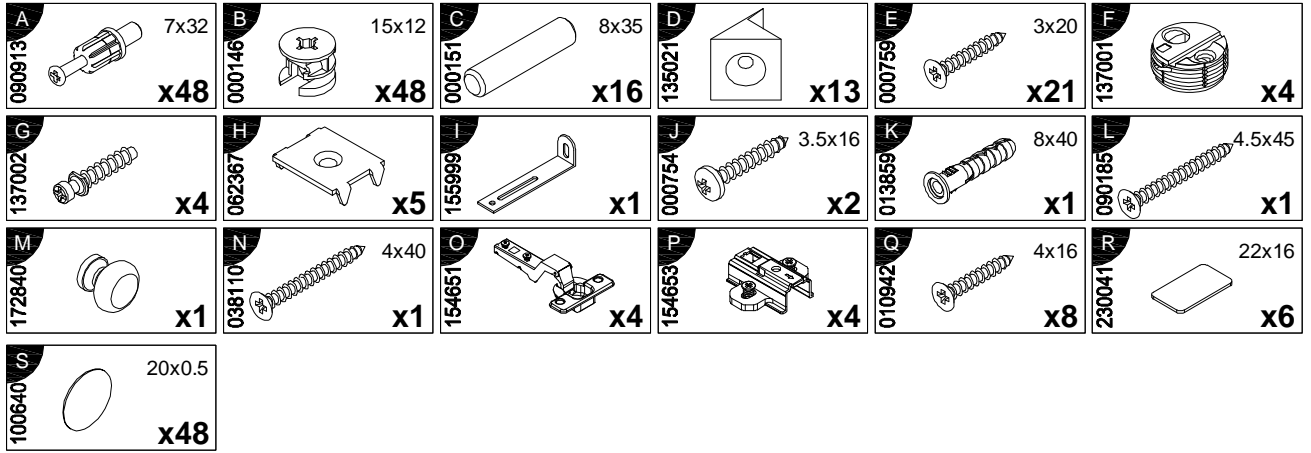

<b>N</b>	<b>Size/MaB (mm)</b>	<b>Qty</b>	<b>✓</b>
1	786x420x22	1	
2	2142x400x16	1	
3	2142x400x16	1	
4	752x354x16	1	
5	752x80x16	2	
6	752x86x22	1	
7	2046x354x16	1	
8	468x353x16	5	
9	268x353x16	5	
10	2048x472x28	1	
11	2067x480x3	1	
12	2067x280x3	1	

# Service - Dienstverlening - Serwis - Servis - Сервисная служба

Name - Naam - Nazwa - Isim - Название

Nr. - No. - Номер

Typ - Type - Тип - Тип

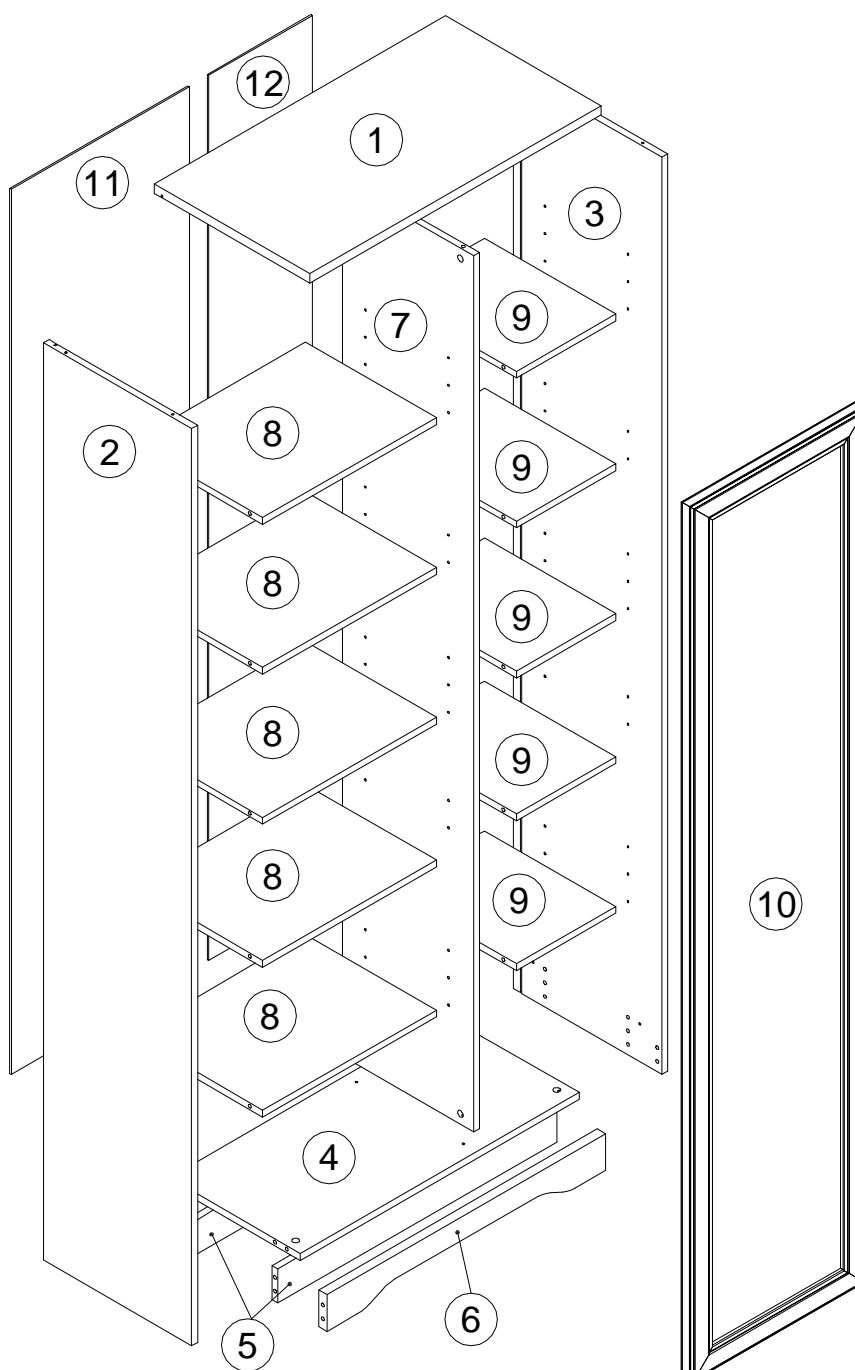
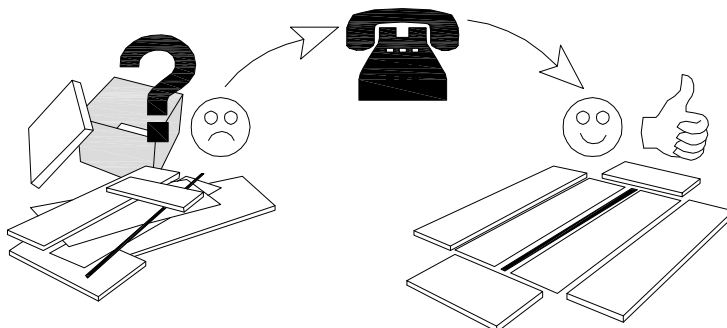
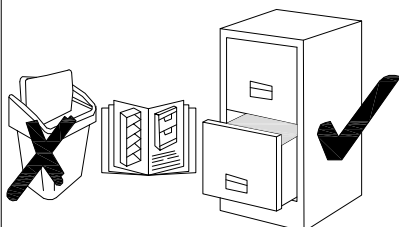

1

<b>A</b> 090913 7x32 x24	<b>G</b> 137002 x4	<b>P</b> 154653 x4
-----------------------------------	--------------------------	--------------------------

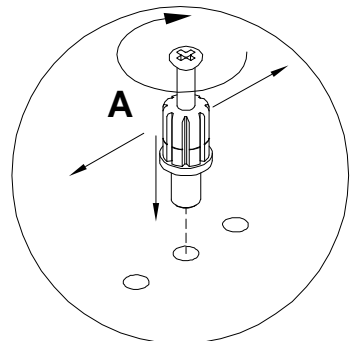
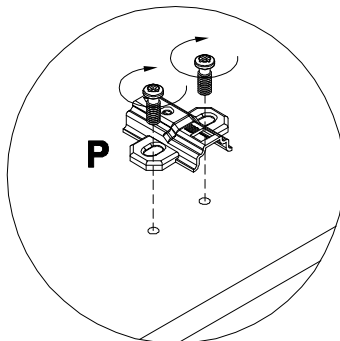
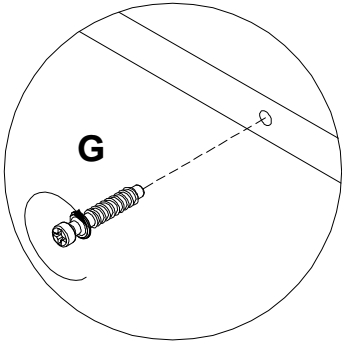
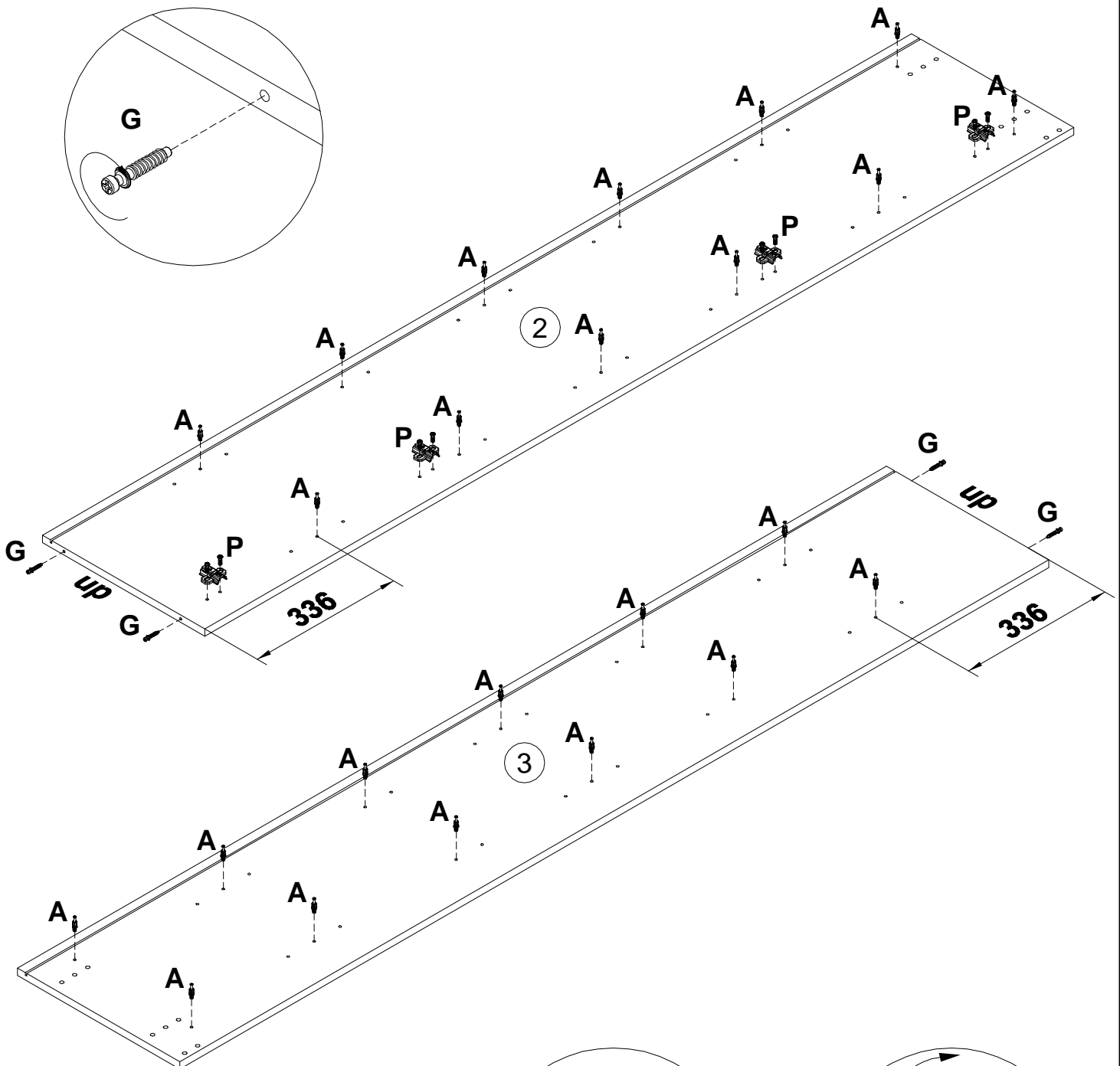

2

A  
090913

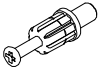

7x32

x20

B  
000146



15x12

x4

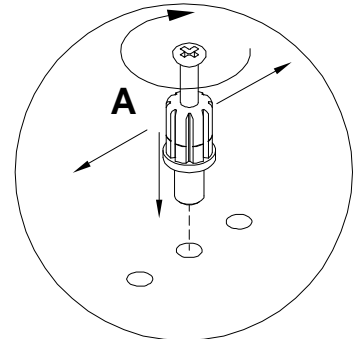
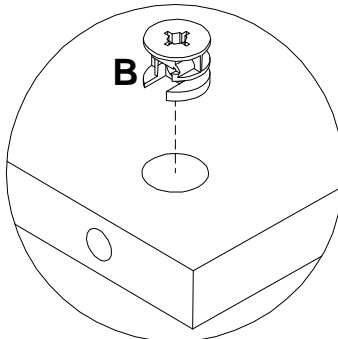
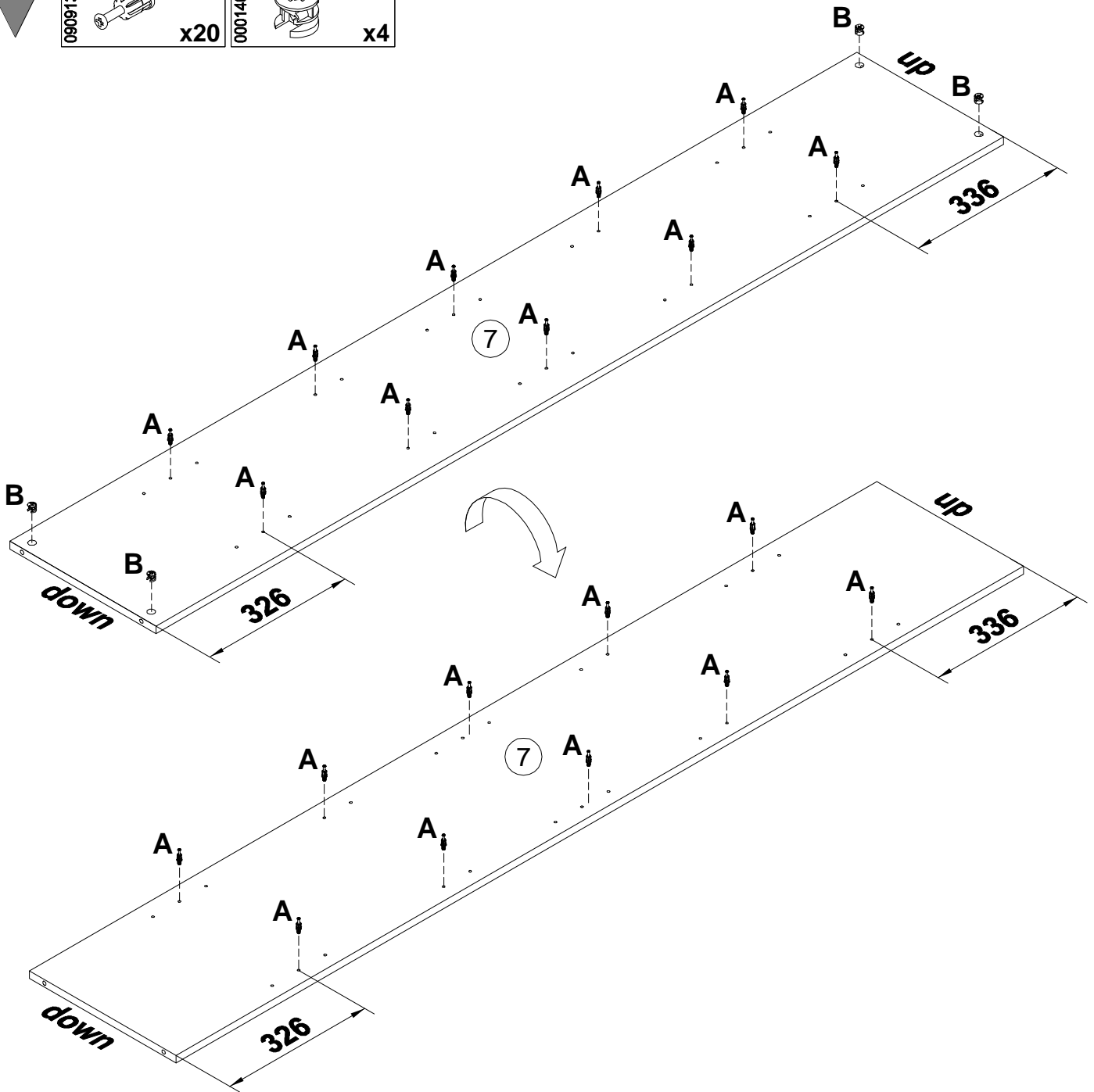

3

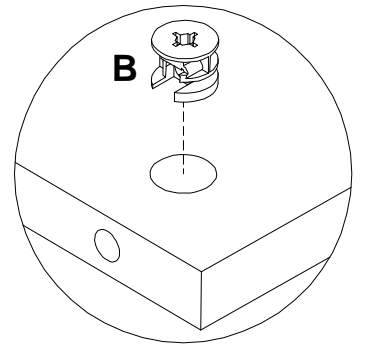
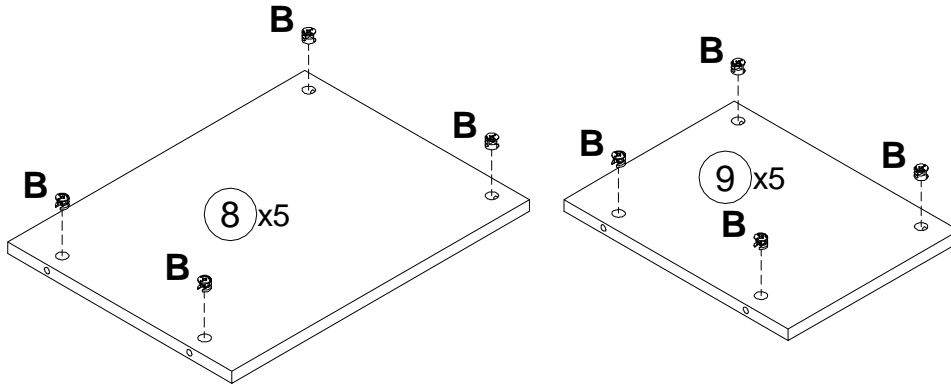
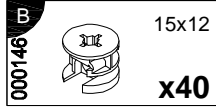

4

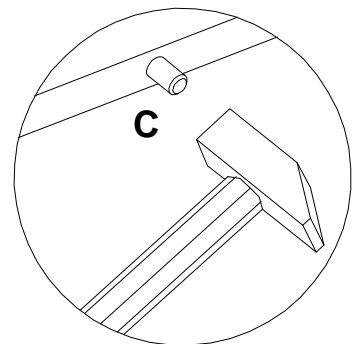
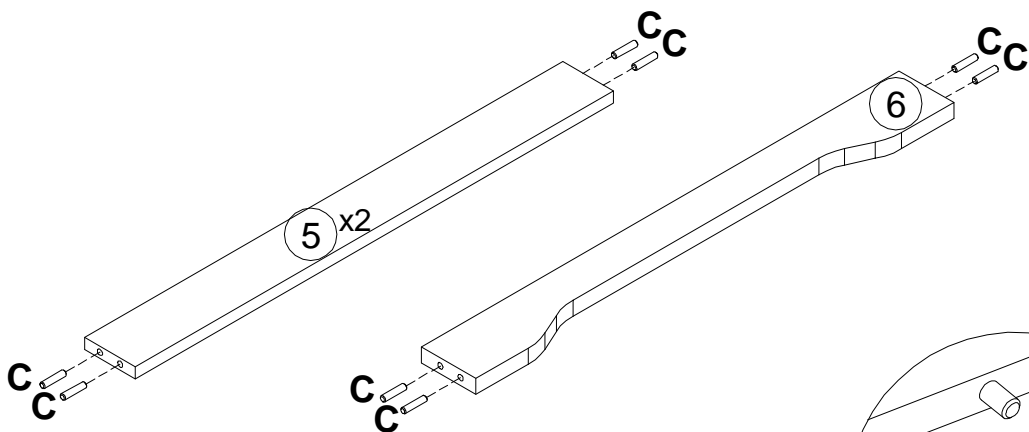
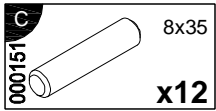

5

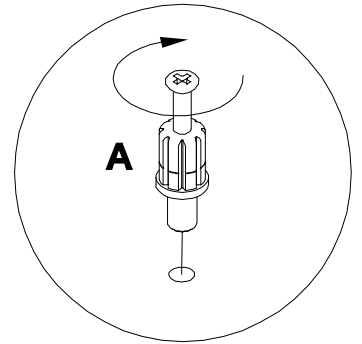
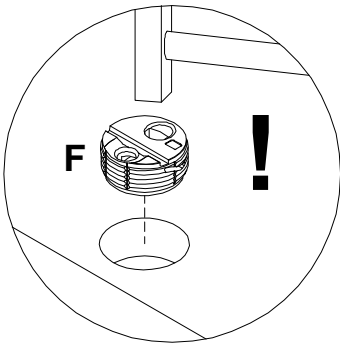
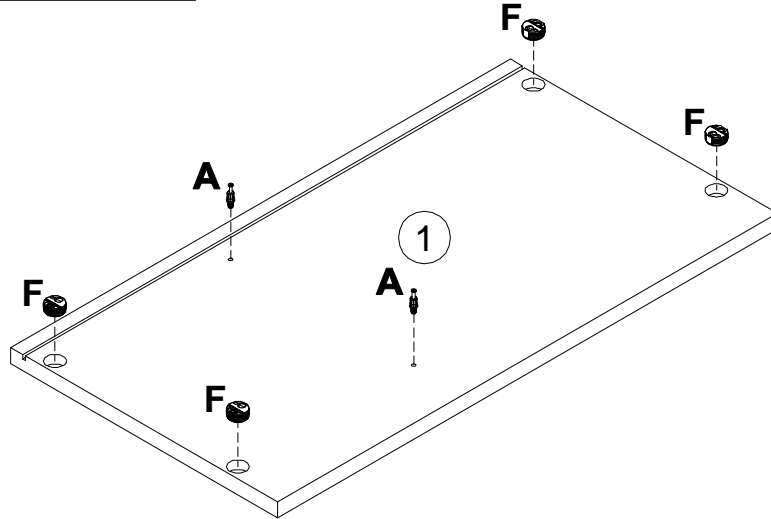
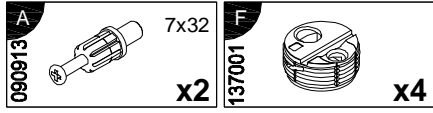

6

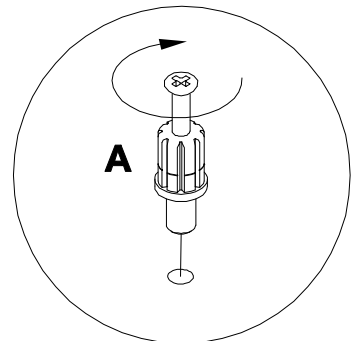
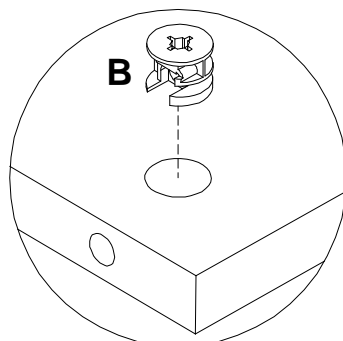
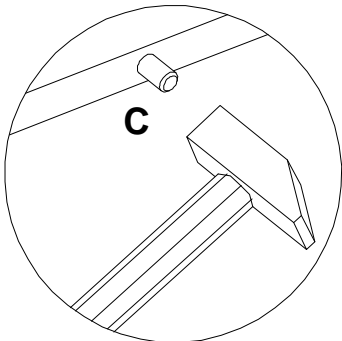
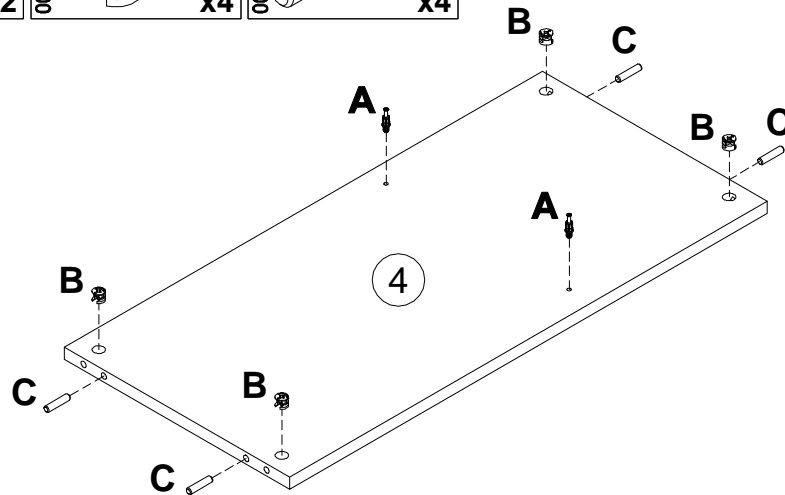
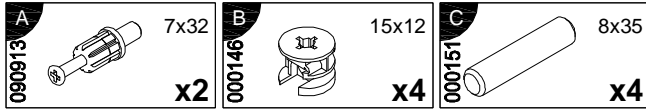

7

7

172840 M x1



038110 N 4x40 x1

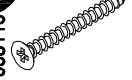

154651 O x4

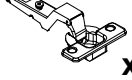

010942 Q 4x16 x8

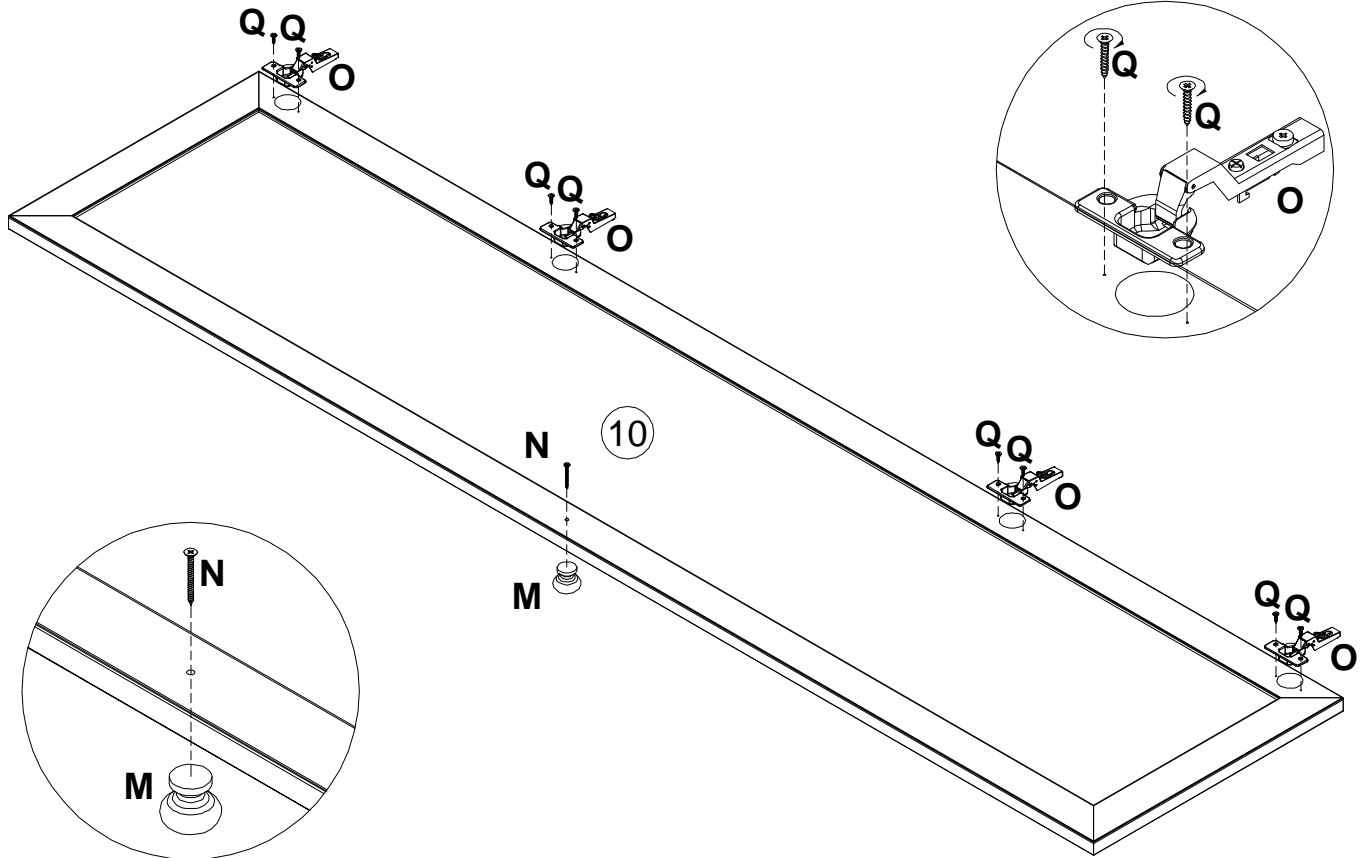

8

100640 S 20x0.5 x2

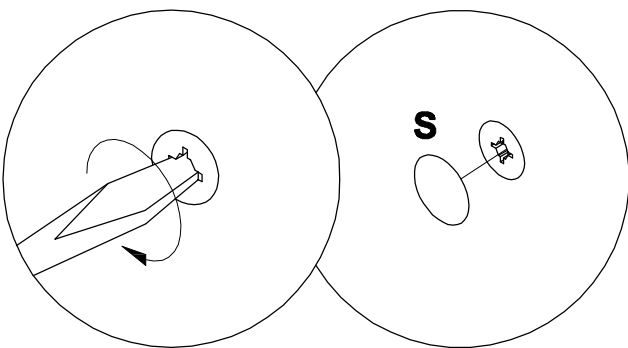
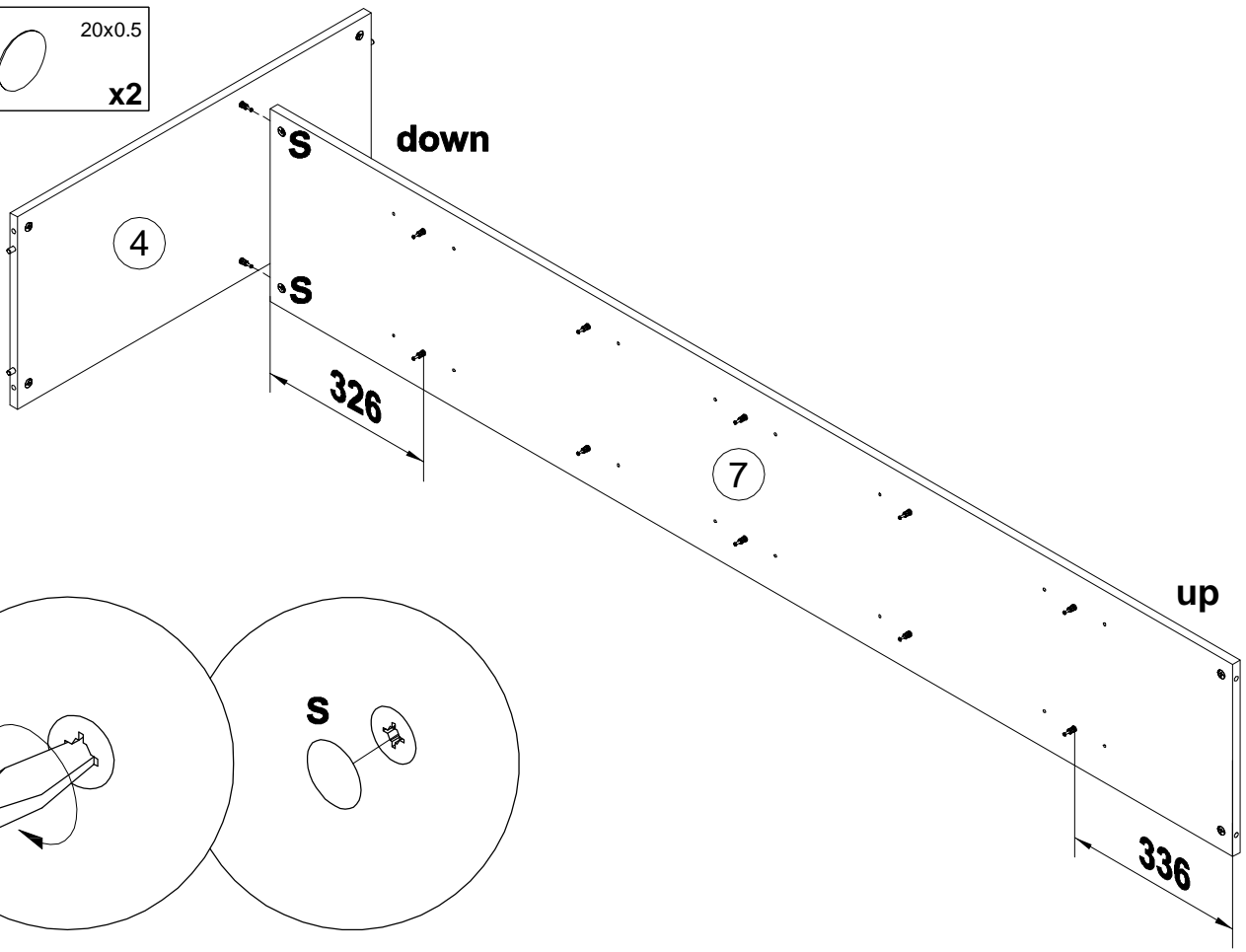



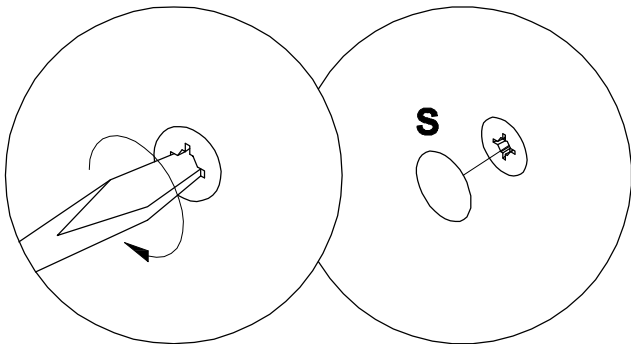
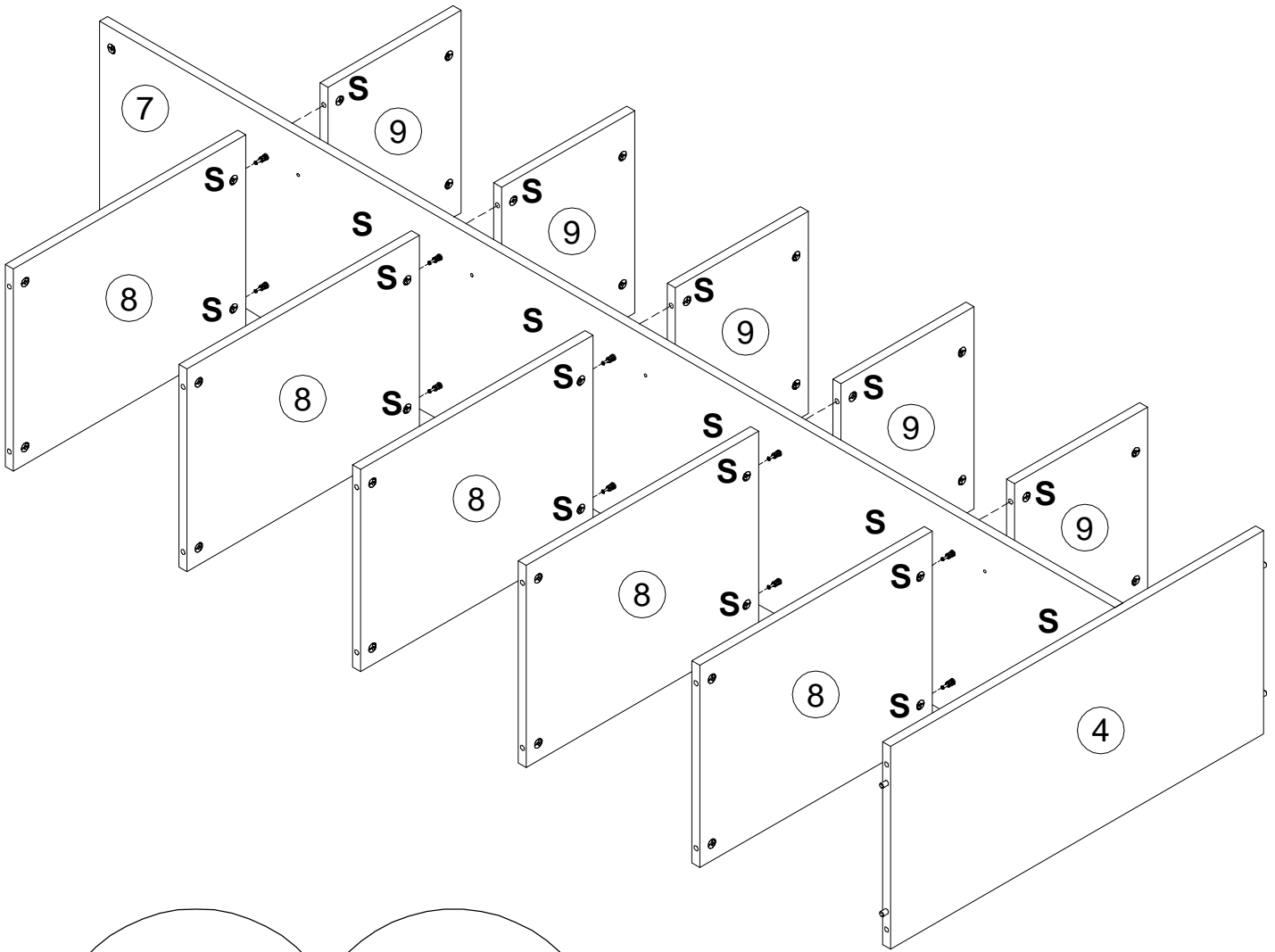
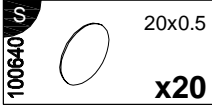

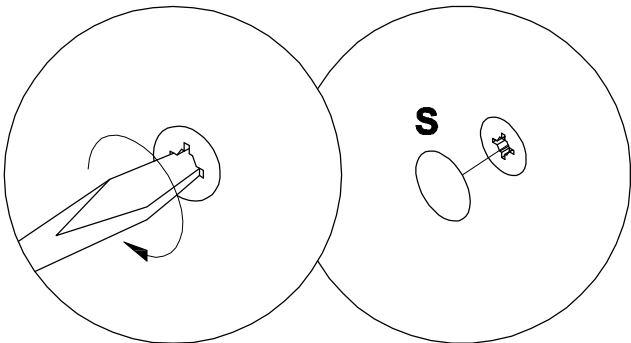
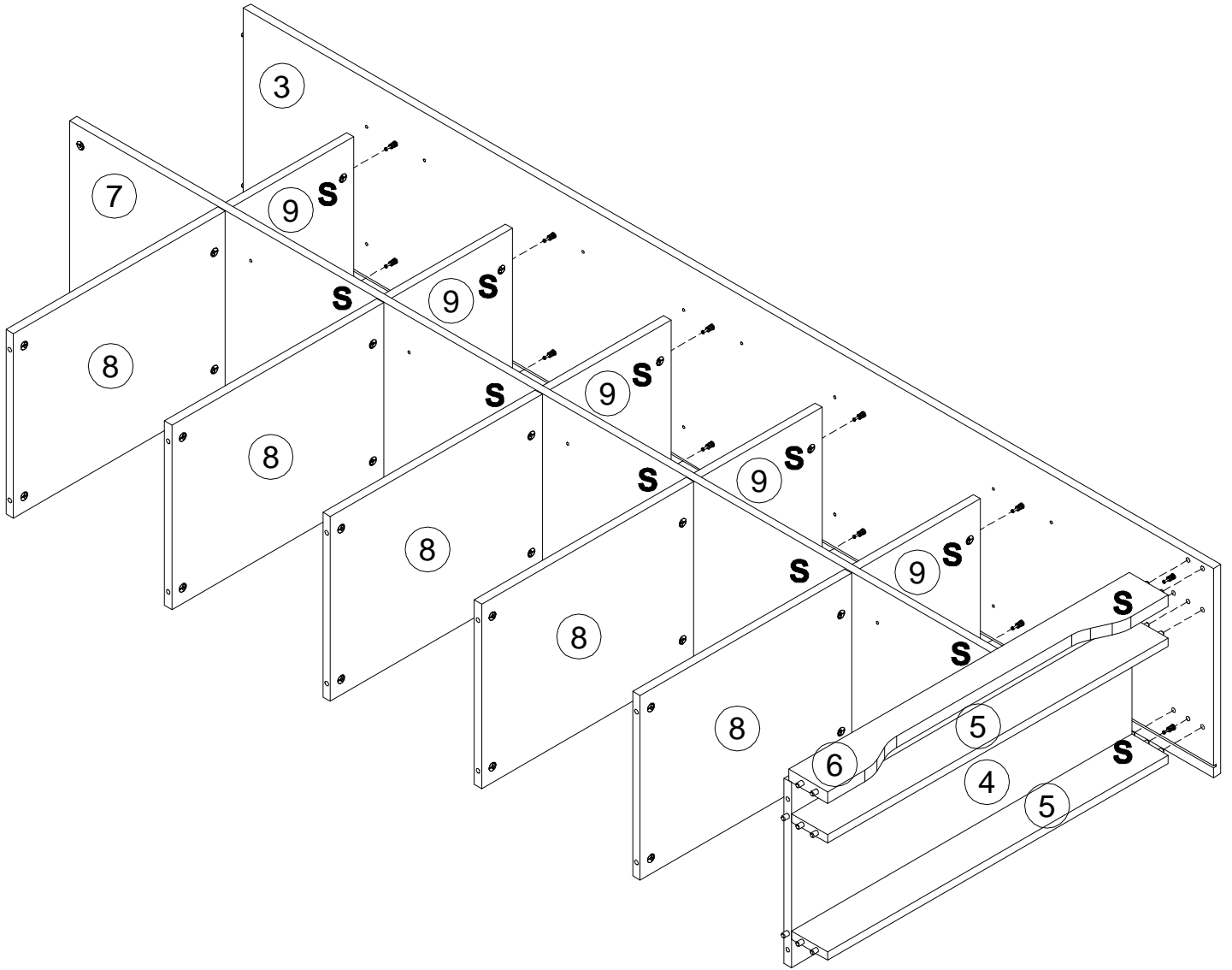
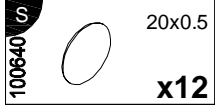

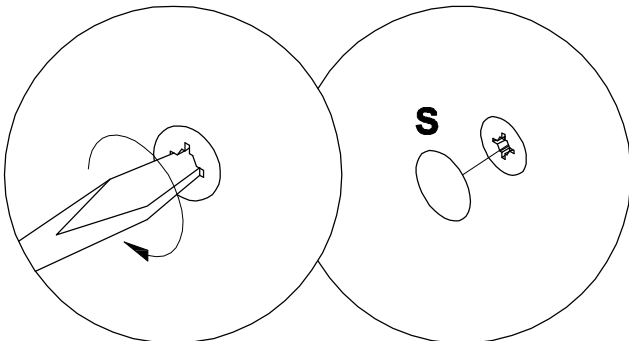
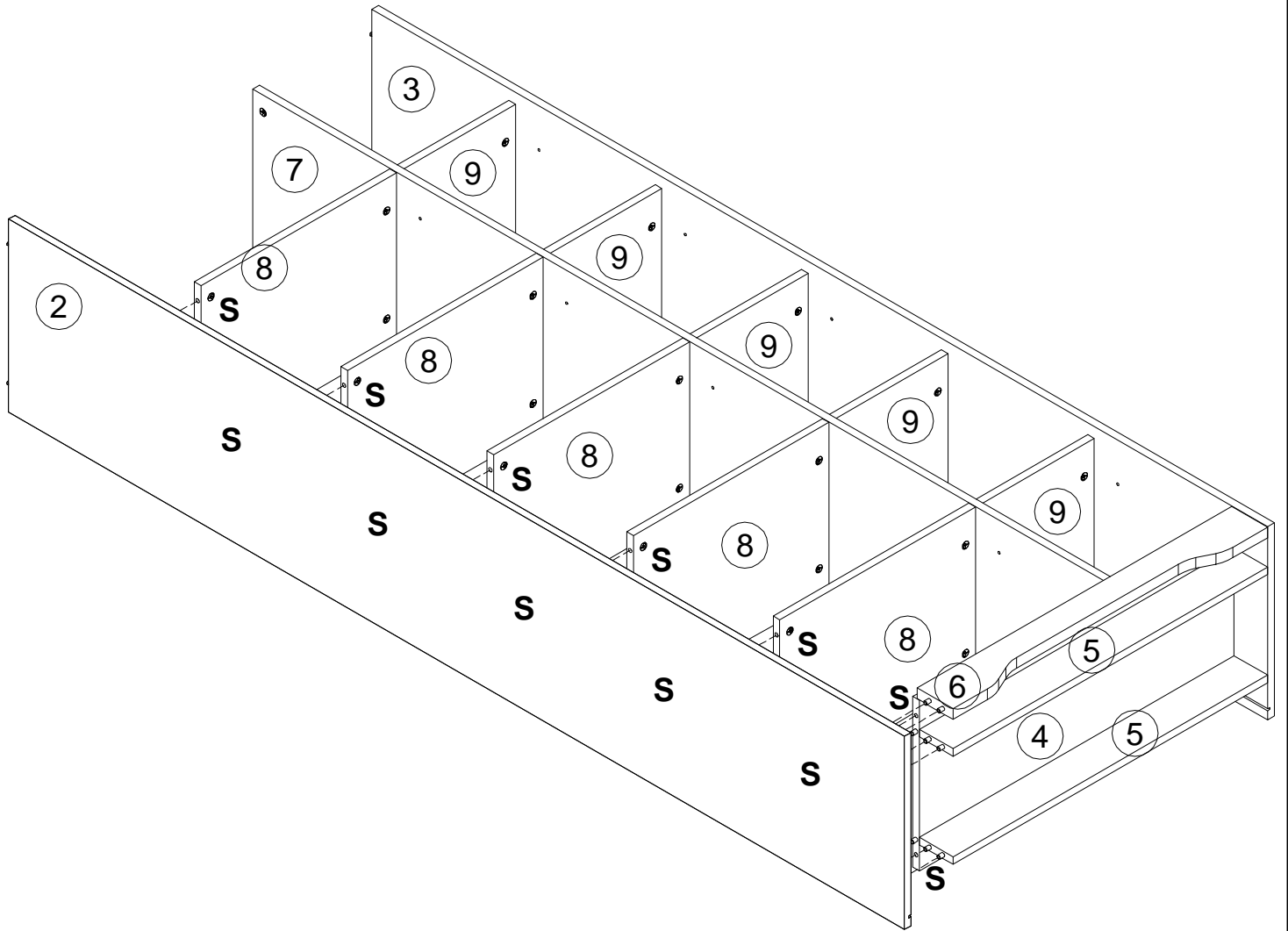

12

230041

R



22x16

x6

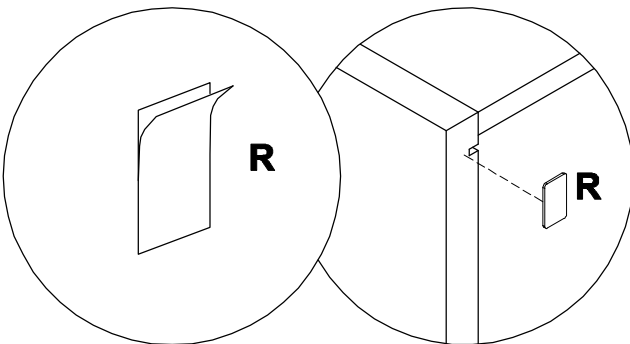
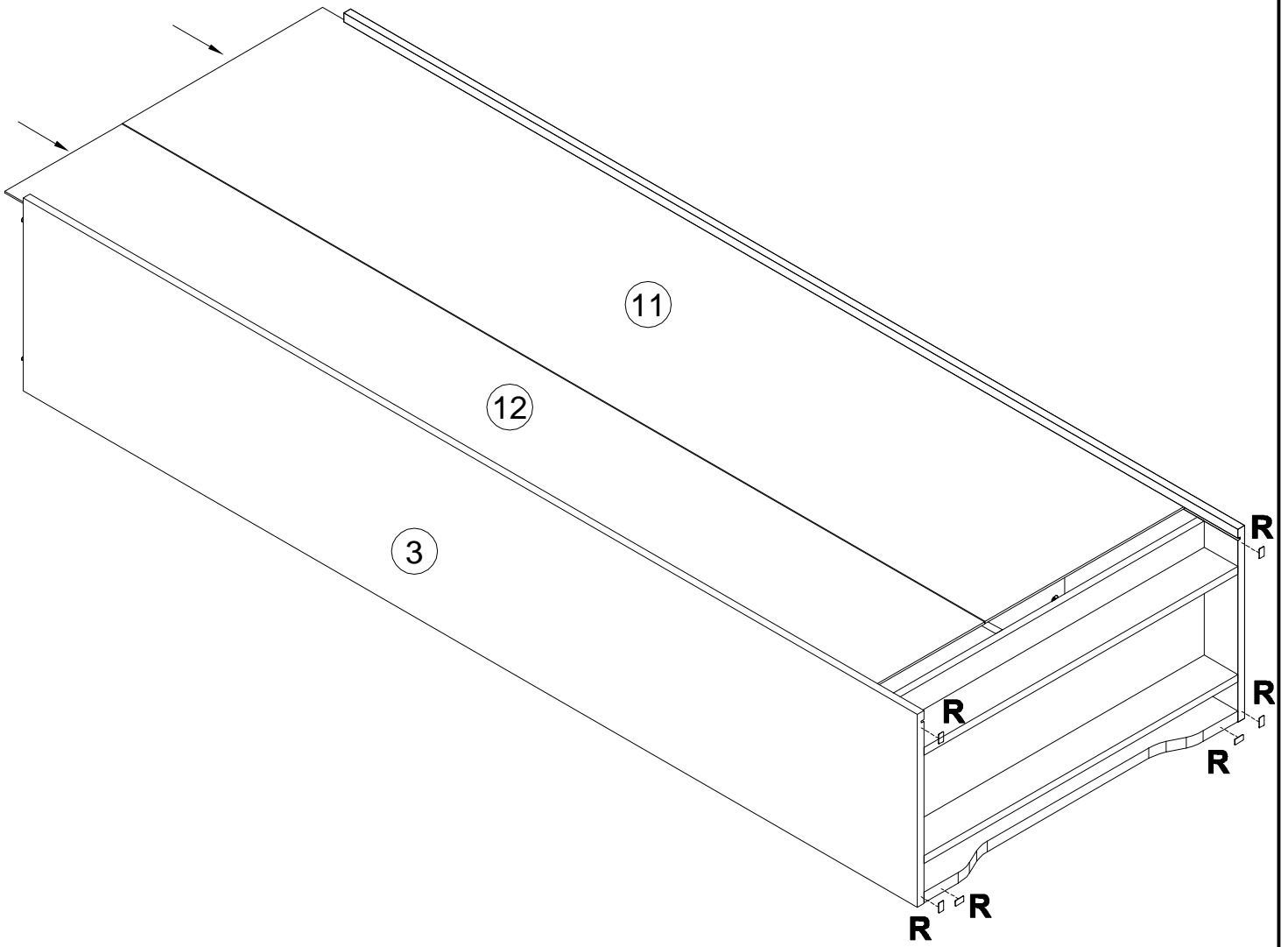

100640  20x0.5  
x2

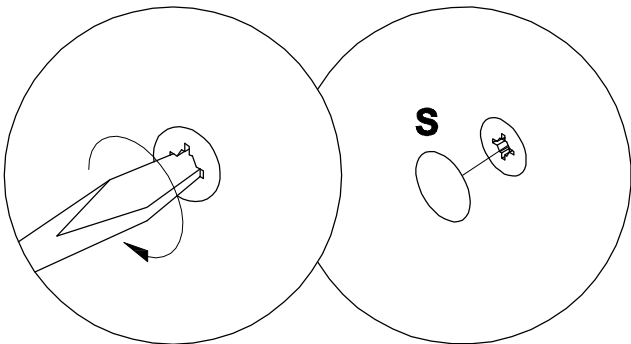
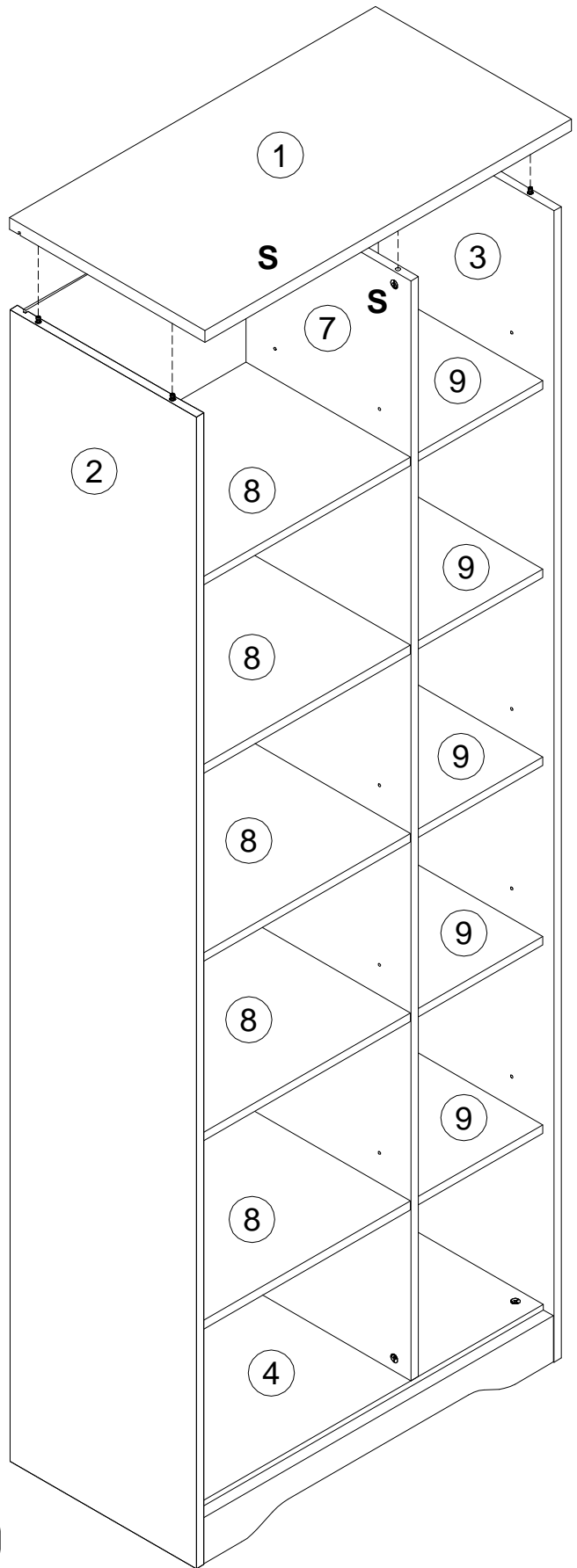
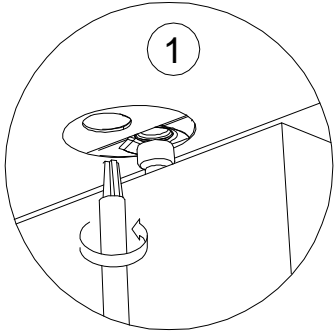

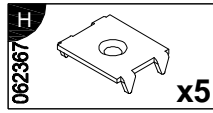
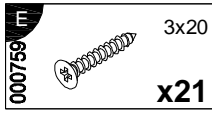
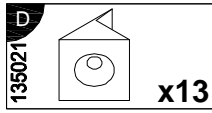

L1=L2

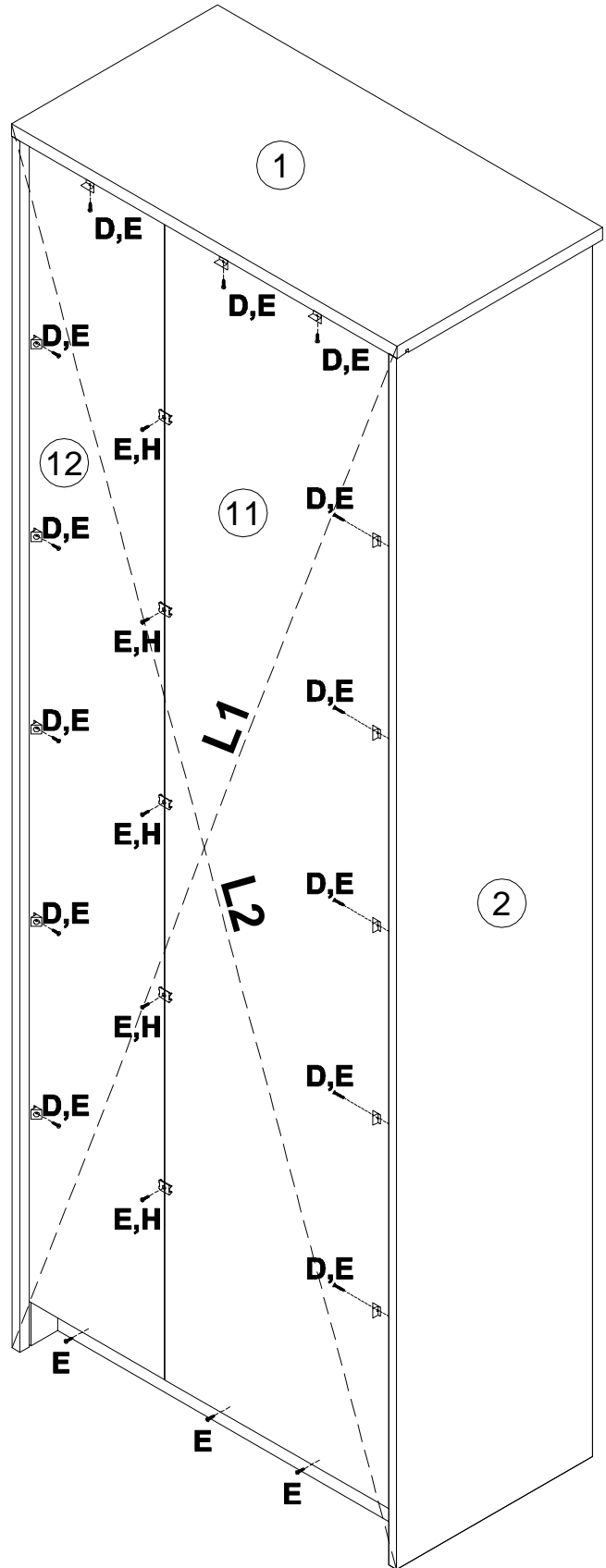
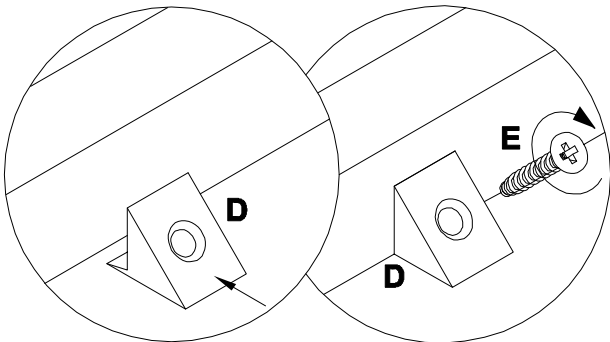
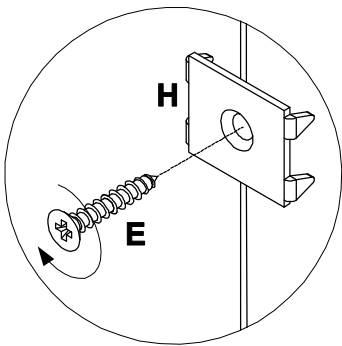
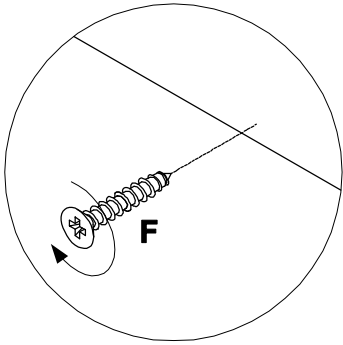

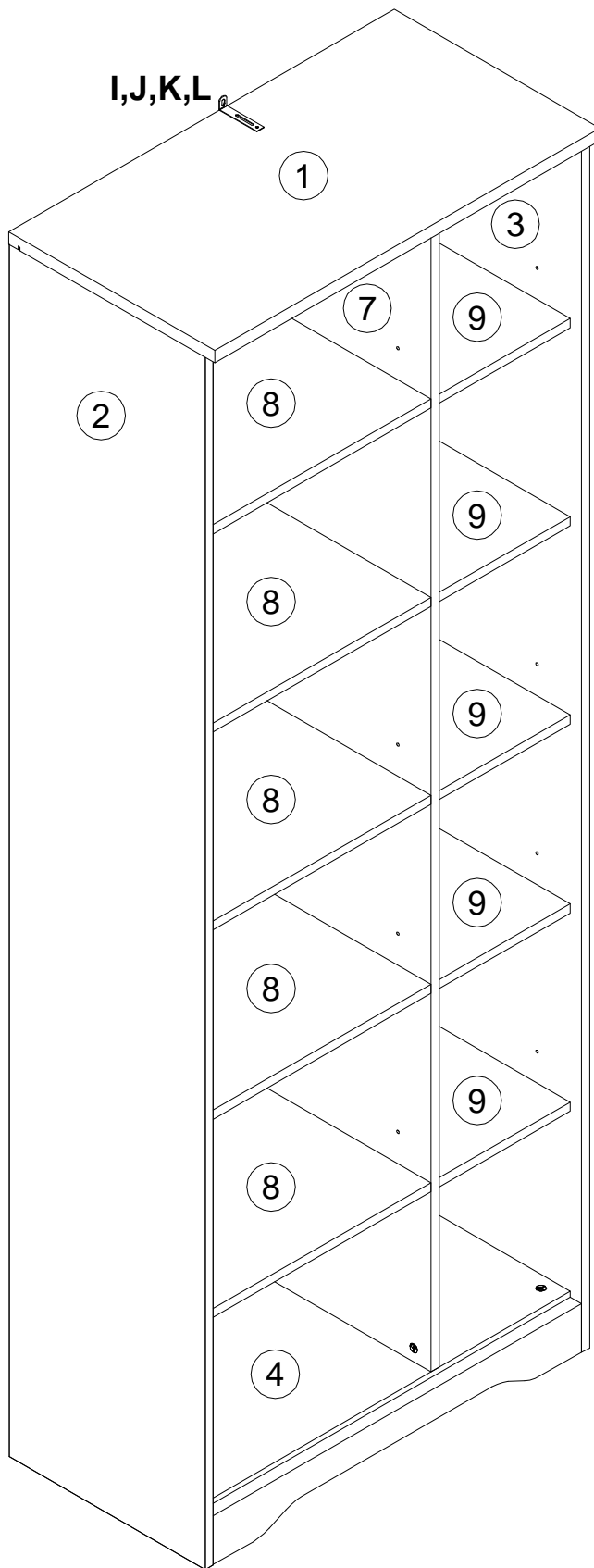
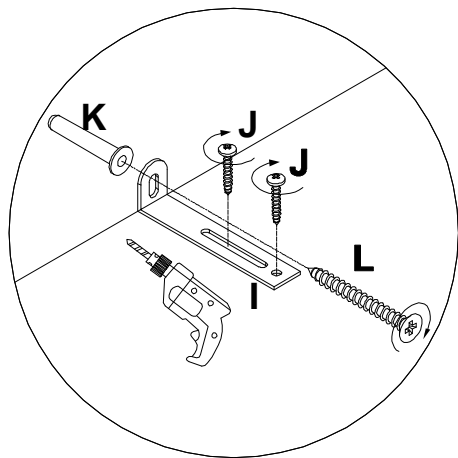
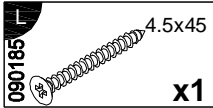
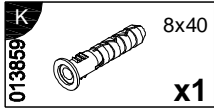
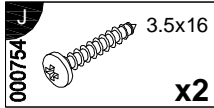
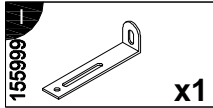

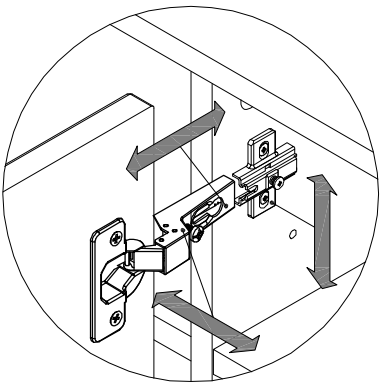
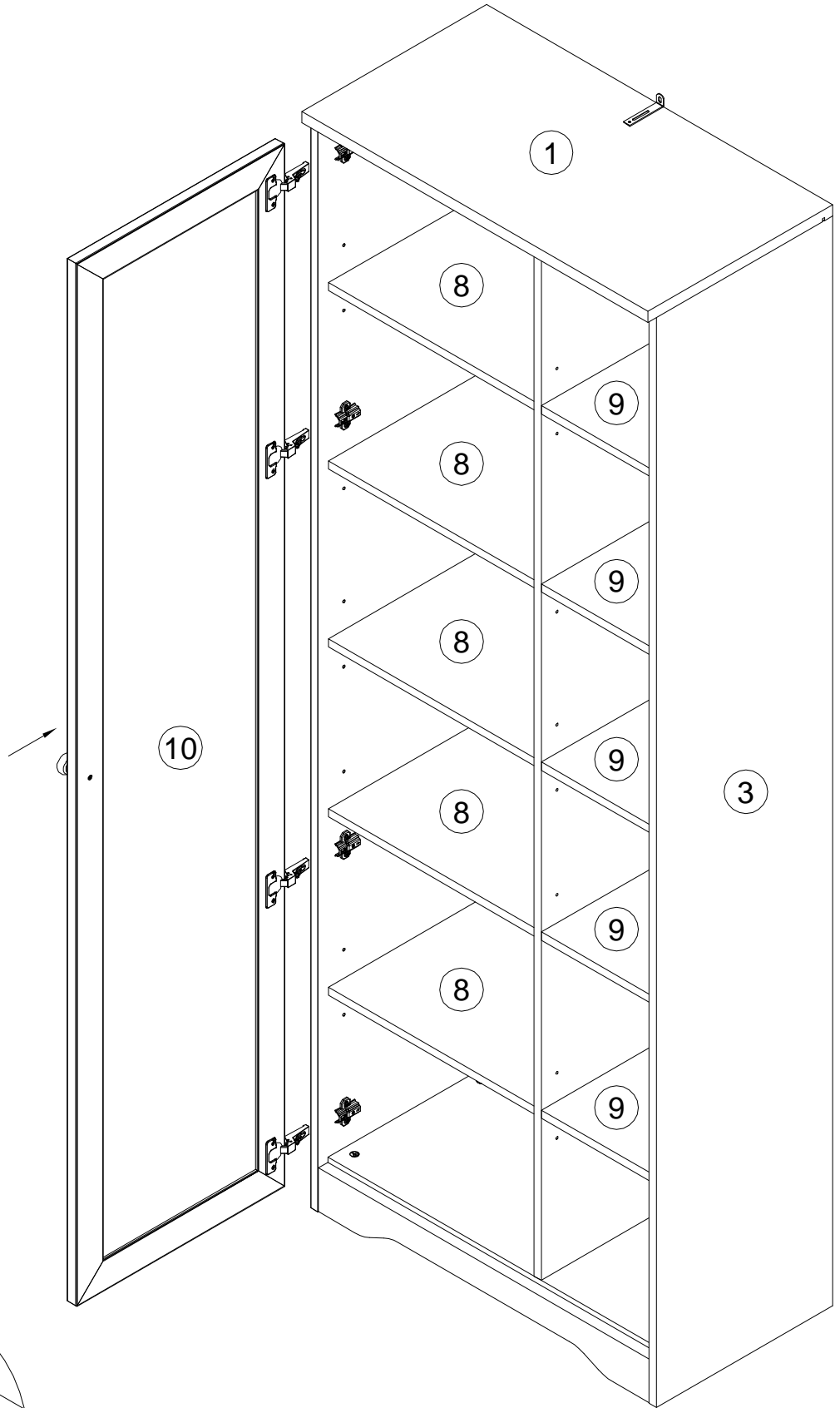





Achtung • Attention • Attenzione  
Opgelet • Uwaga • Pozor • Figyelem  
Atenție • Dikkat • Внимание

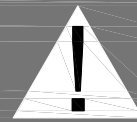

(D)	Wandbefestigung dient als Kippschutz – unbedingt anbringen! Bei einigen Wandtypen kann ein Spezialdübel erforderlich sein!
(GB)	The wall fastening serves to prevent tipping – be absolutely sure to mount it! For certain wall types, a special wall plug may be necessary!
(FR)	La fixation murale sert de protection contre le basculement – à installer impérativement ! Pour certains types de murs il faut des chevilles spéciales !
(IT)	Il fissaggio alla parete serve da protezione anti-ribaltamento – attaccarla assolutamente ! Per alcune strutture di parete può essere necessario un tassello speciale !
(NL)	Bevestiging aan de muur dient als kantelbescherming – zeker en vast bevestigen ! Bij enkele muurtypes is een speciale plug misschien vereist !
(PL)	Mocowanie do ściany jest jednocześnie zabezpieczeniem przed przewróceniem – koniecznie zamontować! Do niektórych rodzajów ścian koniecznie zastosować specjalne kołki mocujące.
(CZ)	Montáž na stěnu slouží jako ochrana proti převrnutí – bezpodmienečně umístěte! Uněkterých typů stěn může být zapotřebí speciální hmoždinka !
(SK)	Upevnenie na stenu slúži ako ochrana proti prevráteniu – bezpodmienečne použite! Pre niektoré druhy stien môže byť potrebná špeciálna hmoždenka !
(HU)	A terméket a falhoz kel rögzíteni, különben az felborulhat! Egyes faltípusoknál speciális tiplit kell használni !
(RO)	Sistemul de fixare la perete servește ca protecție la răsturnare – de montat obligatoriu! Pentru unele tipuri de pereți este posibil să fie necesar un diblu special !
(TR)	Duvardaki sabitleme, devrilmeye karşı bir emniyet tedbiridir ve mutlaka monte edilmelidir! Bazı duvar tiplerinde bunun için özel bir dübel gereklidir !
(RU)	Обязательно установите крепление на стене во избежание опрокидывания ! Для некоторых типов стен может потребоваться специальный дюбель !