

D Werk- und Spanntisch Montageanleitung

meister 



HINWEIS:

- Auf ebenem und festen Untergrund achten!
- Arbeitsplatte gegen Verrutschen sichern!

ACHTUNG!

Bei überstehenden Werkstücken besteht Kippgefahr!

WICHTIG

Für späteres Nachschlagen aufbewahren!
Anleitung sorgfältig lesen!



Vor jeder Benutzung ist die Werkbank auf
Beschädigungen zu prüfen!



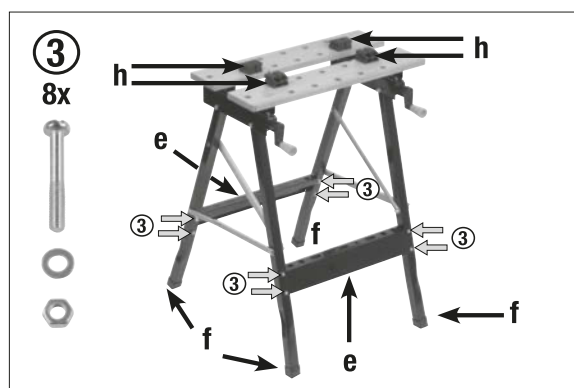
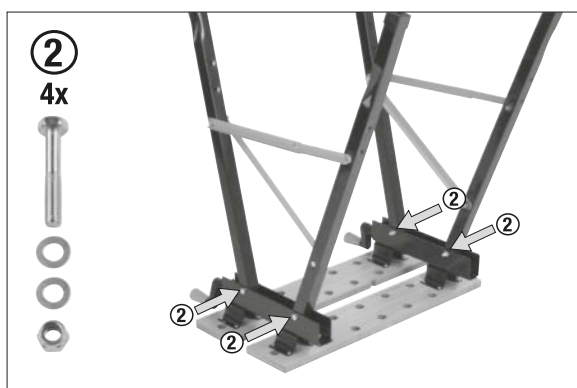
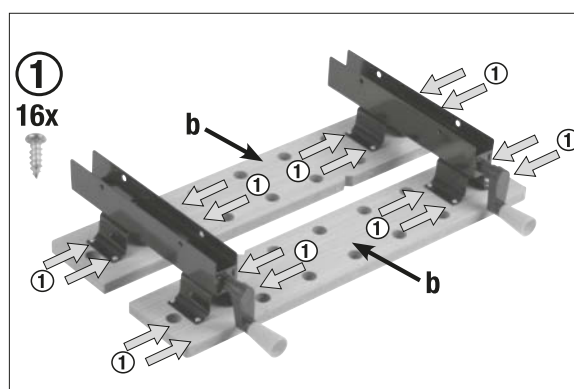
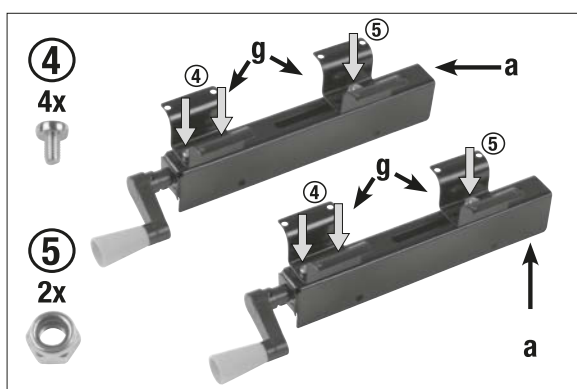
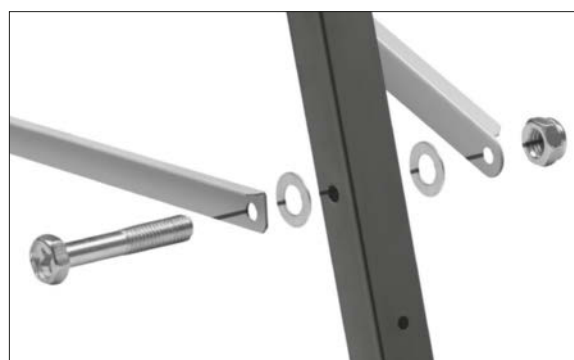
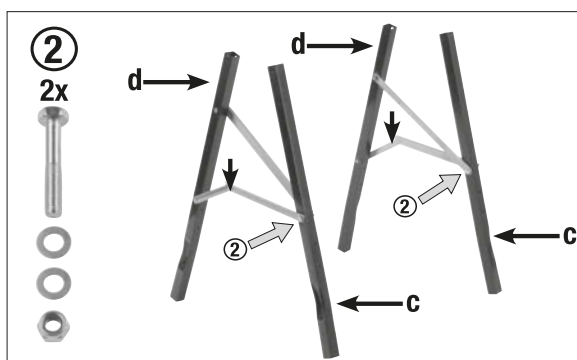
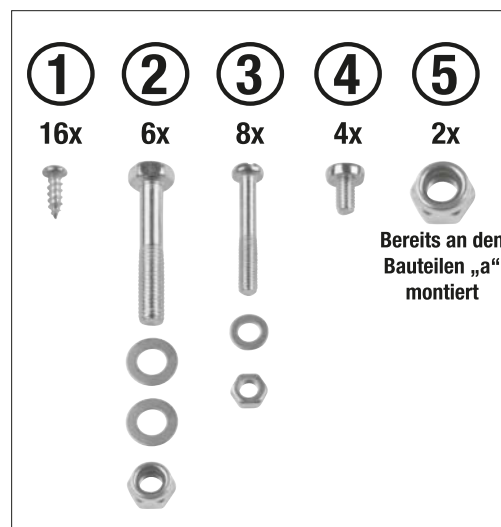
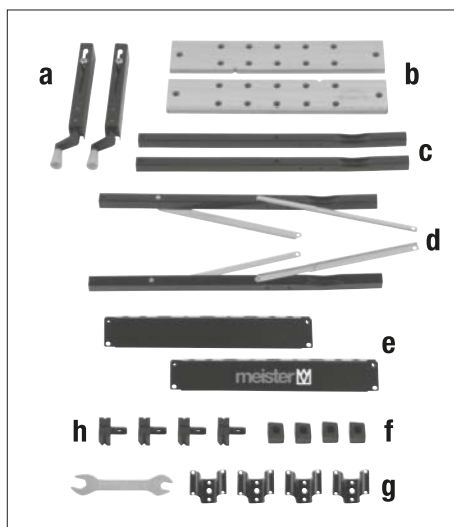

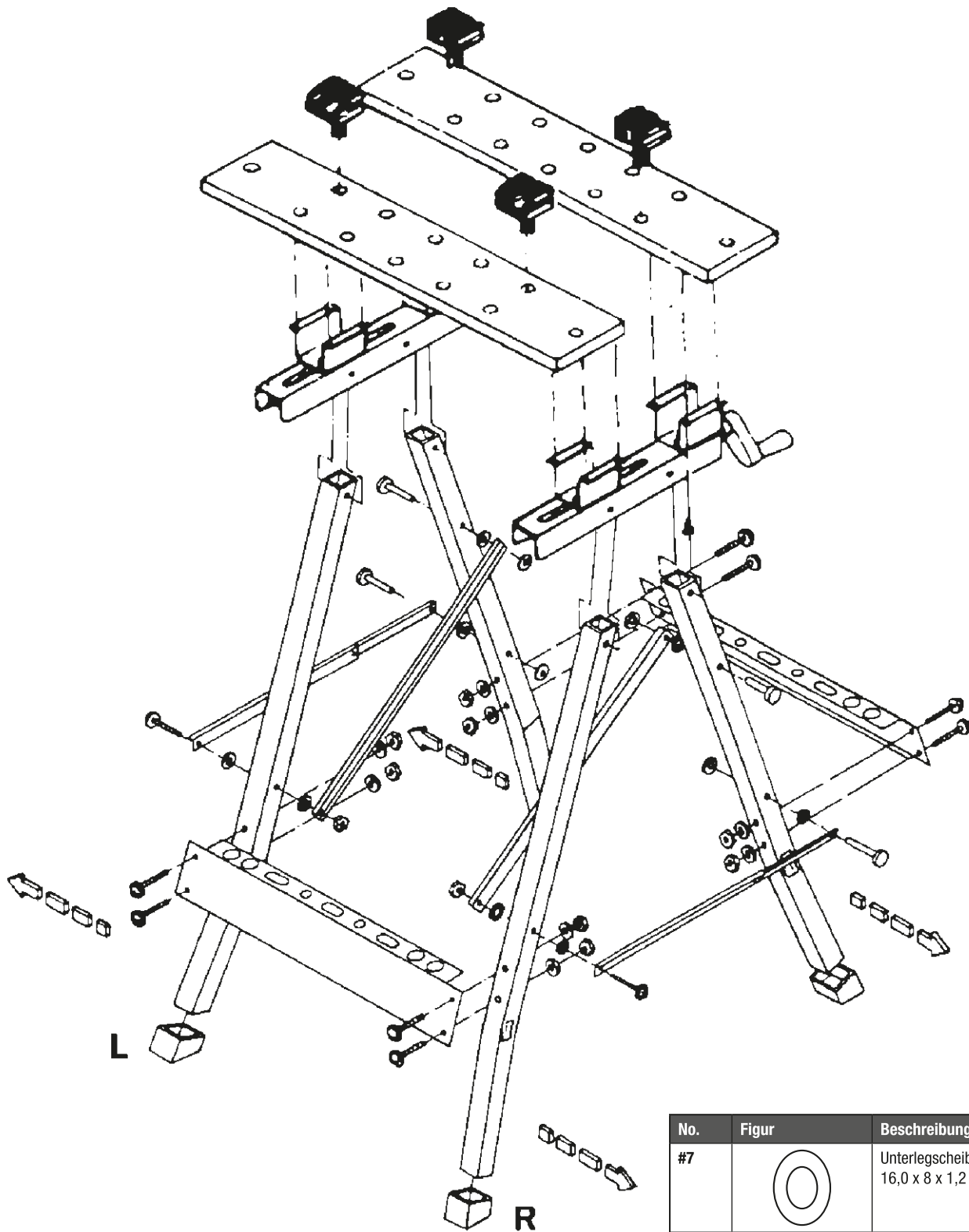

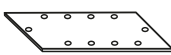
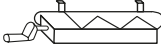
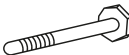
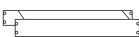
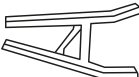

Nr. 9079100

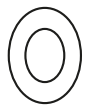



No.	Figur	Beschreibung	Anzahl
#1		Tischplatte	2 pcs
#2		Gleitblock	2 pcs
#3		Bolzen (hex.)	4 pcs
#4		Querstab	2 pcs
#5		Tischbein	2 pcs
#6		Kunststoff-Fuß	4 pcs

No.	Figur	Beschreibung	Anzahl
#7		Unterlegscheibe 16,0 x 8 x 1,2	4 pcs
#8		Holzschraube 4,8 x 16 mm	16 pcs
#9		Bolzen (Phillips) M6 x PH1 x 37 mm	8 pcs
#10		Mutter M6 x P1	8 pcs
#11		Mutter M8 x P1,2	4 pcs
#12		Hemmkeil	4 pcs
#13		Unterlegscheibe 13 x 6 x 1,2	8 pcs

CZ Pracovní a upínací stůl

Návod na montáž

meister 



UPOZORNĚNÍ:

- Dbejte na rovný a pevný podklad!
- Pracovní desku zajistěte proti sesmeknutí!

POZOR!

Pokud obrobky přečnívají, hrozí nebezpečí převrácení!

WICHTIG

Uschovejte pro použití v budoucnu!
Návod si pečlivě přečtěte!

Před každým použitím si zkontrolujte, zda nedošlo k poškození pracovního stolu!



Nr. 9079100

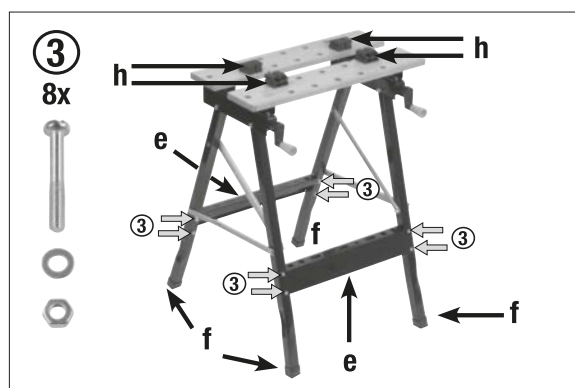
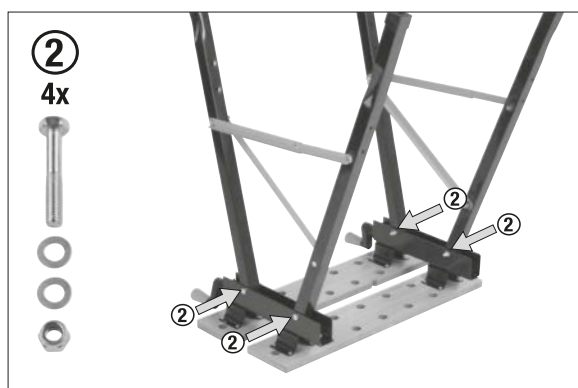
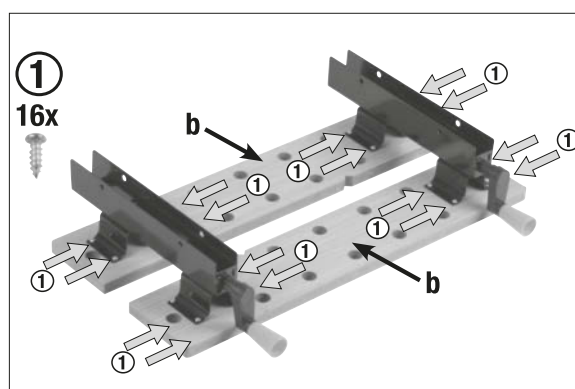
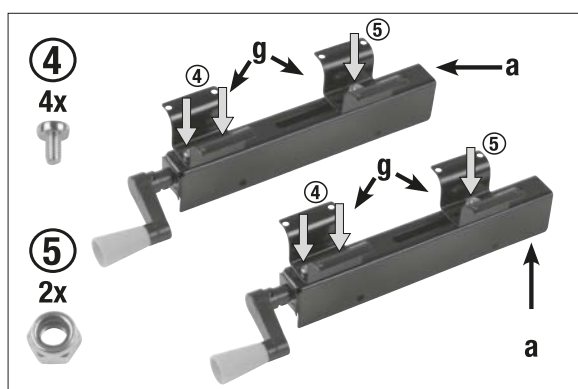
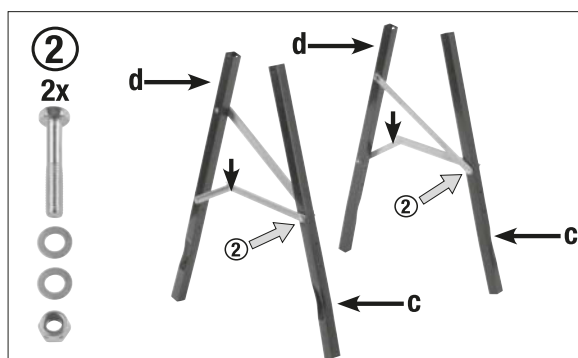
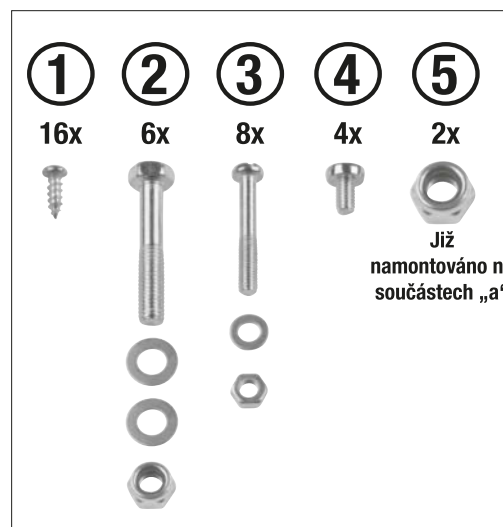
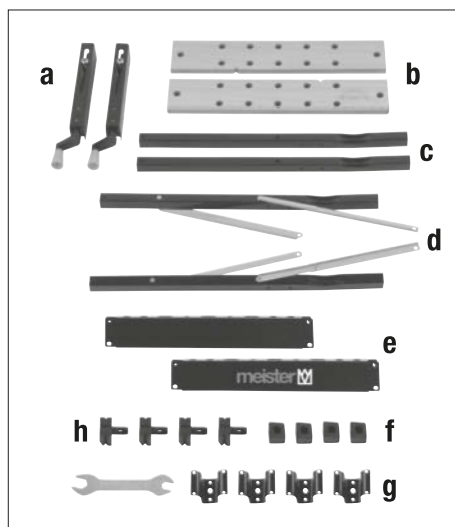

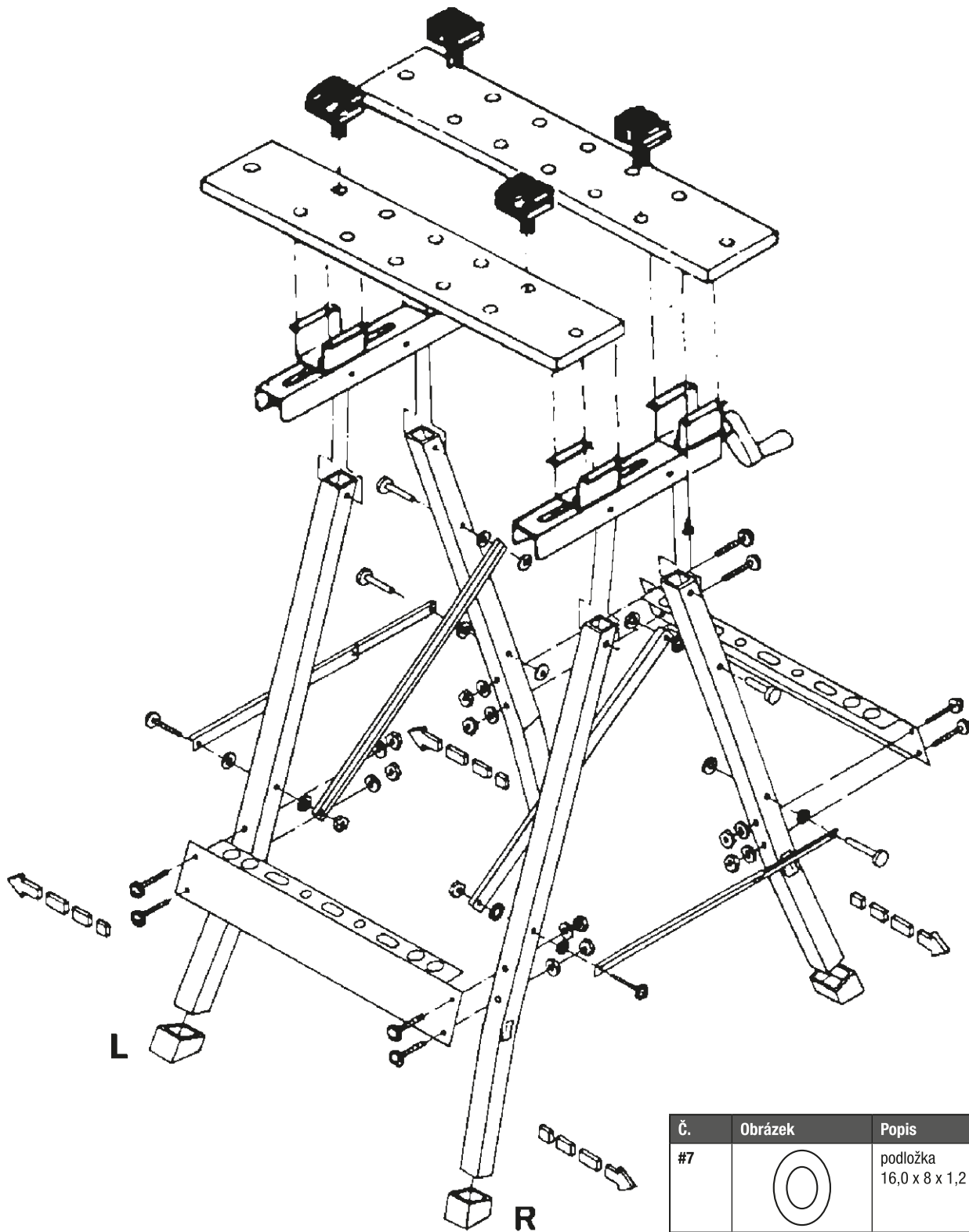

Č.	Obrázek	Popis	Počet
#1		stolní deska	2 ks
#2		posuvný blok	2 ks
#3		svorník (hex.)	4 ks
#4		příčka	2 ks
#5		noha stolu	2 ks
#6		plastová patka	4 ks

Č.	Obrázek	Popis	Počet
#7		podložka 16,0 x 8 x 1,2	4 ks
#8		vrut 4,8 x 16 mm	16 ks
#9		svorník (Phillips) M6 x PH1 x 37 mm	8 ks
#10		matice M6 x P1	8 ks
#11		matice M8 x P1,2	4 ks
#12		brzdící klín	4 ks
#13		podložka 13 x 6 x 1,2	8 ks

F Table de travail et de serrage

Instructions de montage

meister 



REMARQUE :

- Veiller à utiliser un support stable et de niveau !
- Protéger le plan de travail contre tout glissement !

Attention !

En cas de pièces à usiner qui dépassent, il existe un risque de basculement !

IMPORTANT

Conserver afin de s'y reporter ultérieurement !

Lire attentivement les instructions !

Avant toute utilisation, il convient de vérifier si l'établi ne présente pas de dommages !



Nr. 9079100

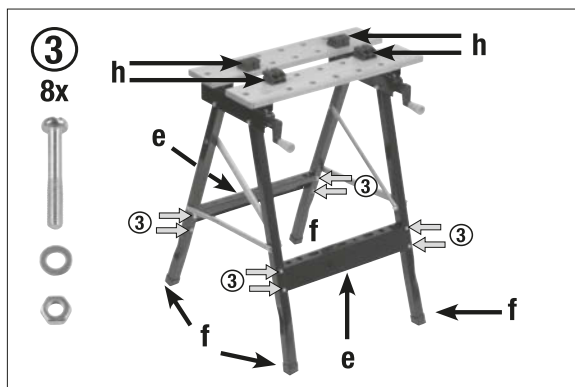
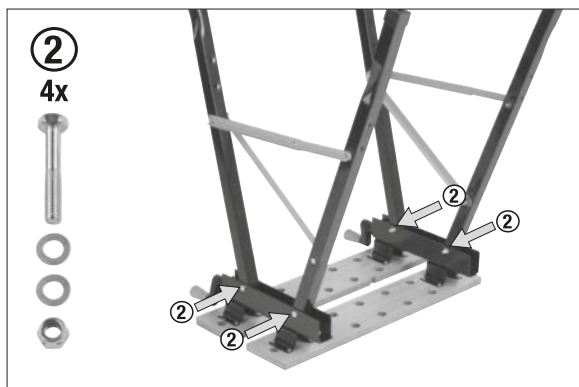
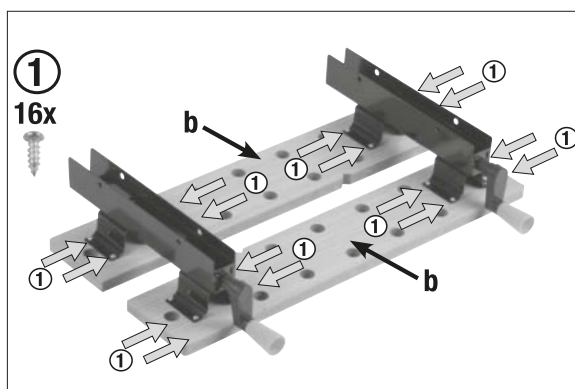
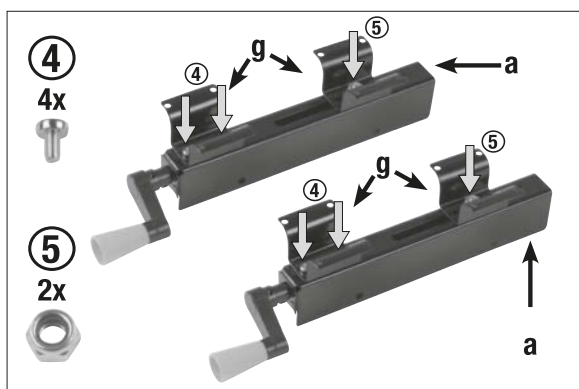
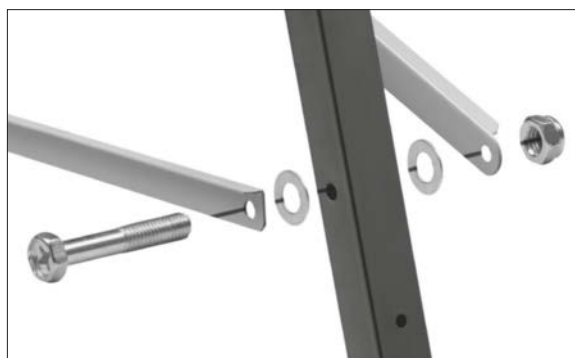
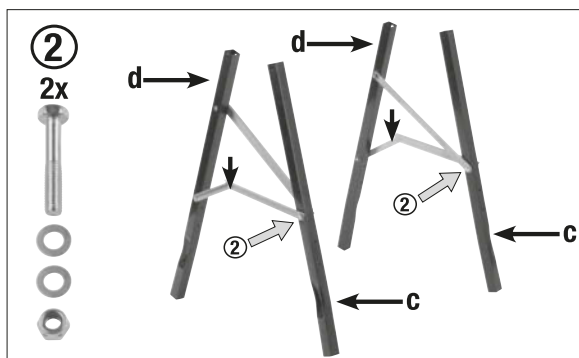
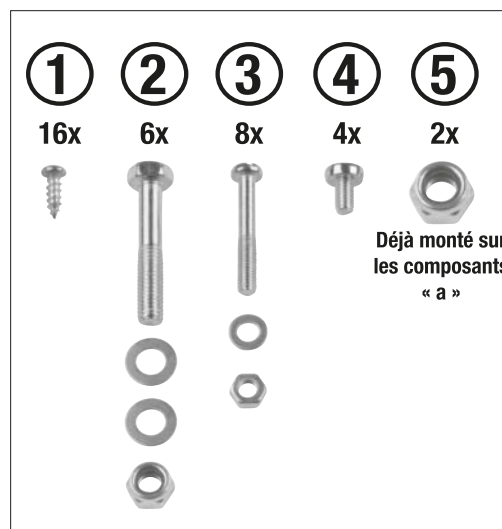
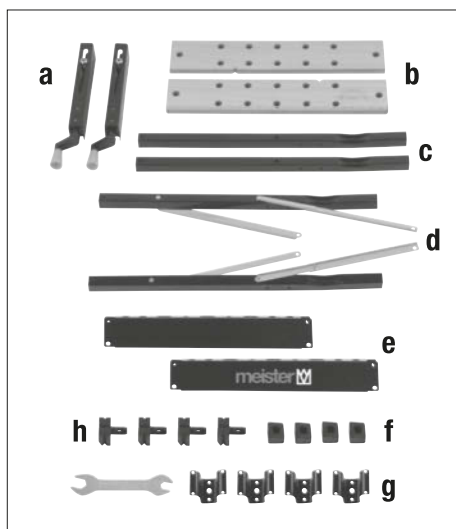

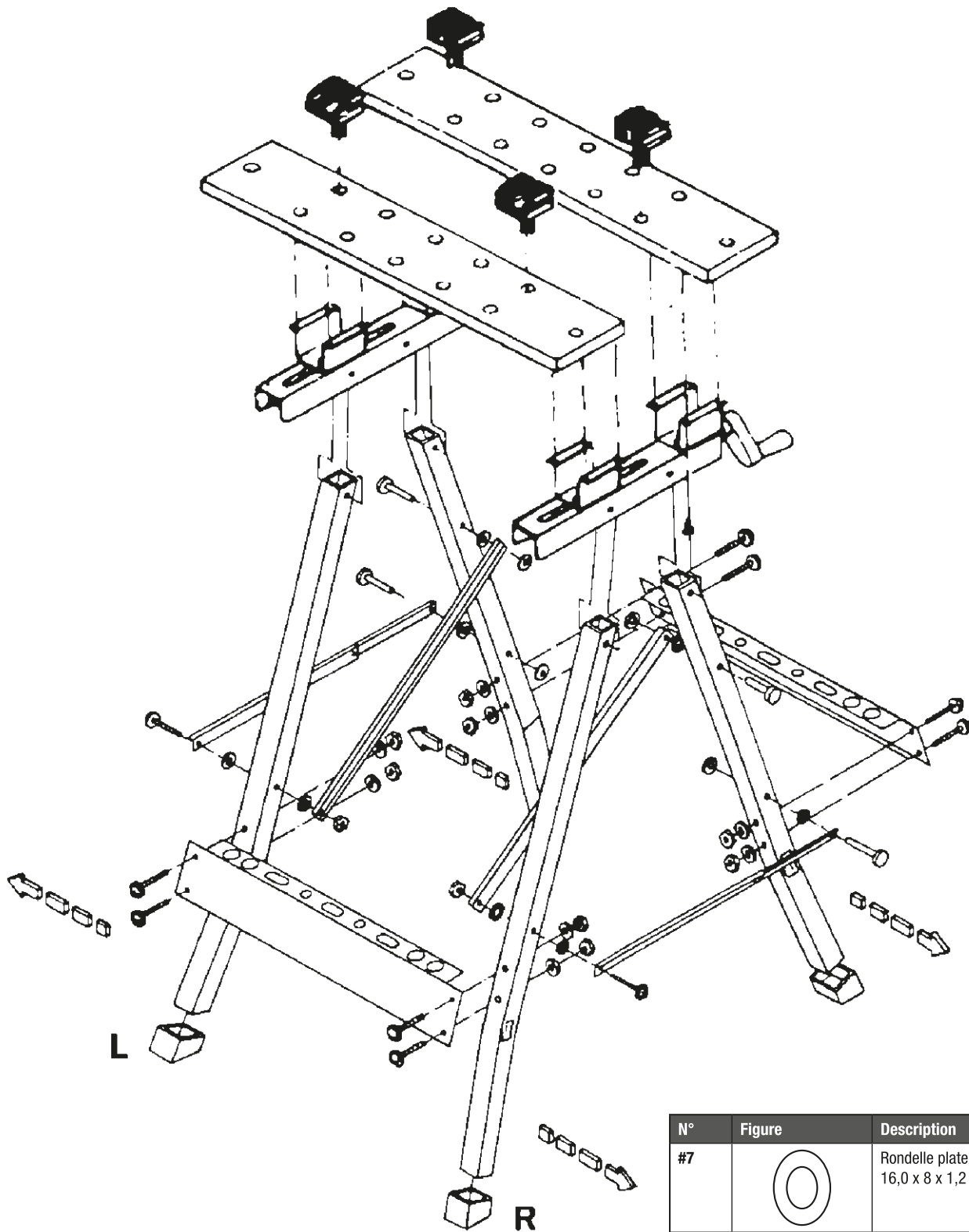

N°	Figure	Description	Nombre
#1		Plateau de table	2 pcs
#2		Bloc coulissant	2 pcs
#3		Boulon (hex.)	4 pcs
#4		Barre transversale	2 pcs
#5		Pied de table	2 pcs
#6		Pied en plastique	4 pcs

N°	Figure	Description	Nombre
#7		Rondelle plate 16,0 x 8 x 1,2	4 pcs
#8		Vis à bois 4,8 x 16 mm	16 pcs
#9		Boulon (Phillips) M6 x PH1 x 37 mm	8 pcs
#10		Écrou M6 x P1	8 pcs
#11		Écrou M8 x P1,2	4 pcs
#12		Cale	4 pcs
#13		Rondelle plate 13 x 6 x 1,2	8 pcs

GB Workbench and vice

Assembly instructions

meister 



NOTE:

- Pay attention to ensure an even and solid surface!
- Secure the workbench to prevent slipping!

Caution!

There is a risk of tipping when the workpiece protrudes!

IMPORTANT

Store for subsequent reference!

Read the instructions carefully!

Before each use, check the workbench for damages!



Nr. 9079100

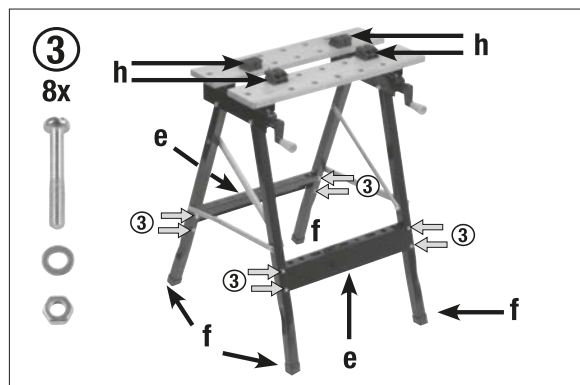
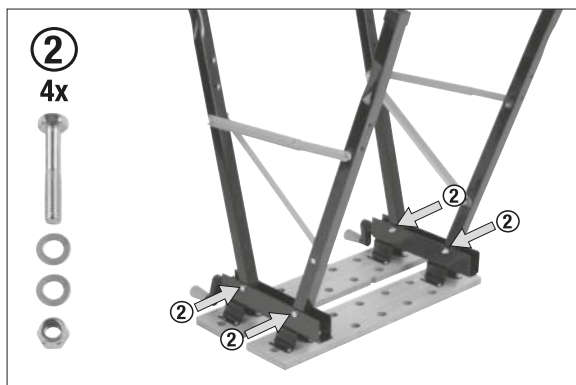
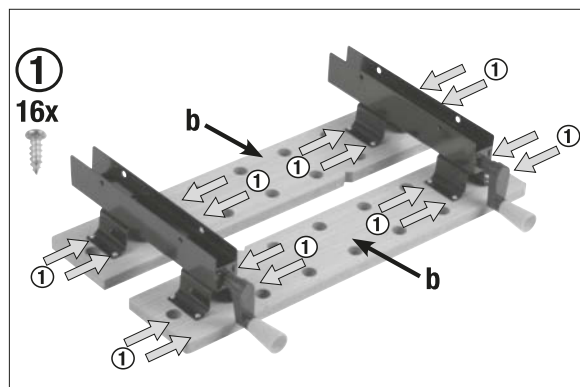
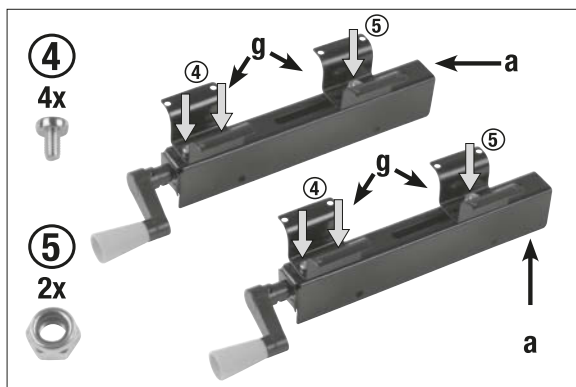
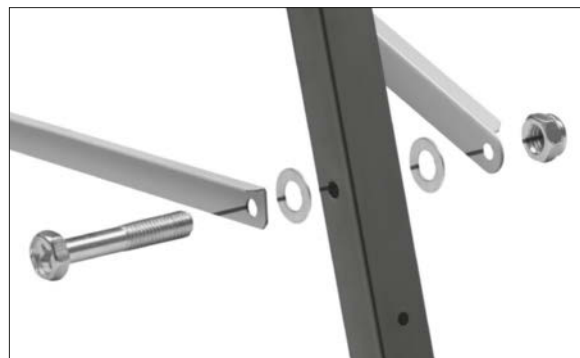
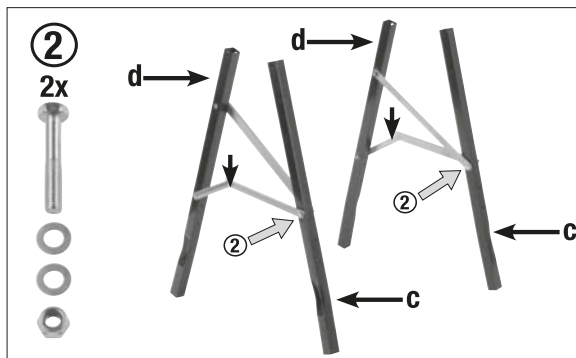
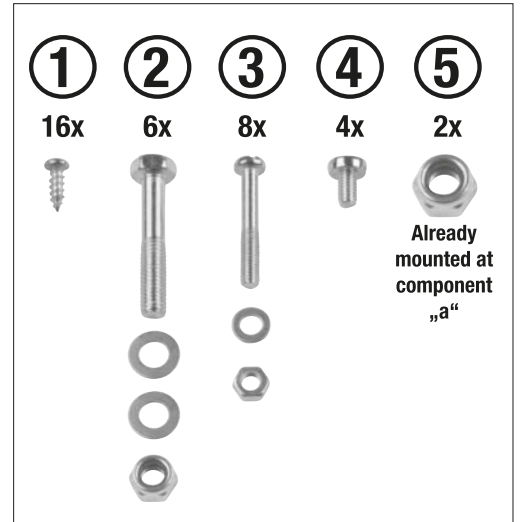
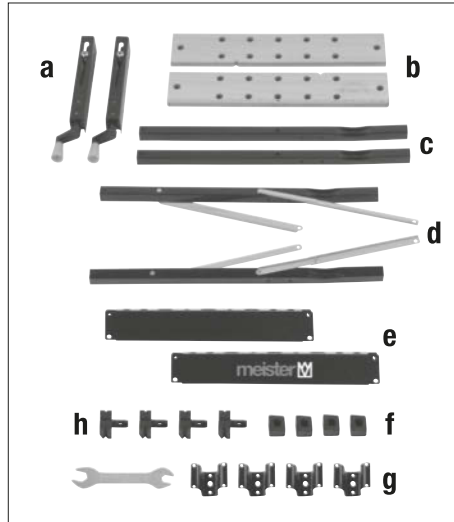

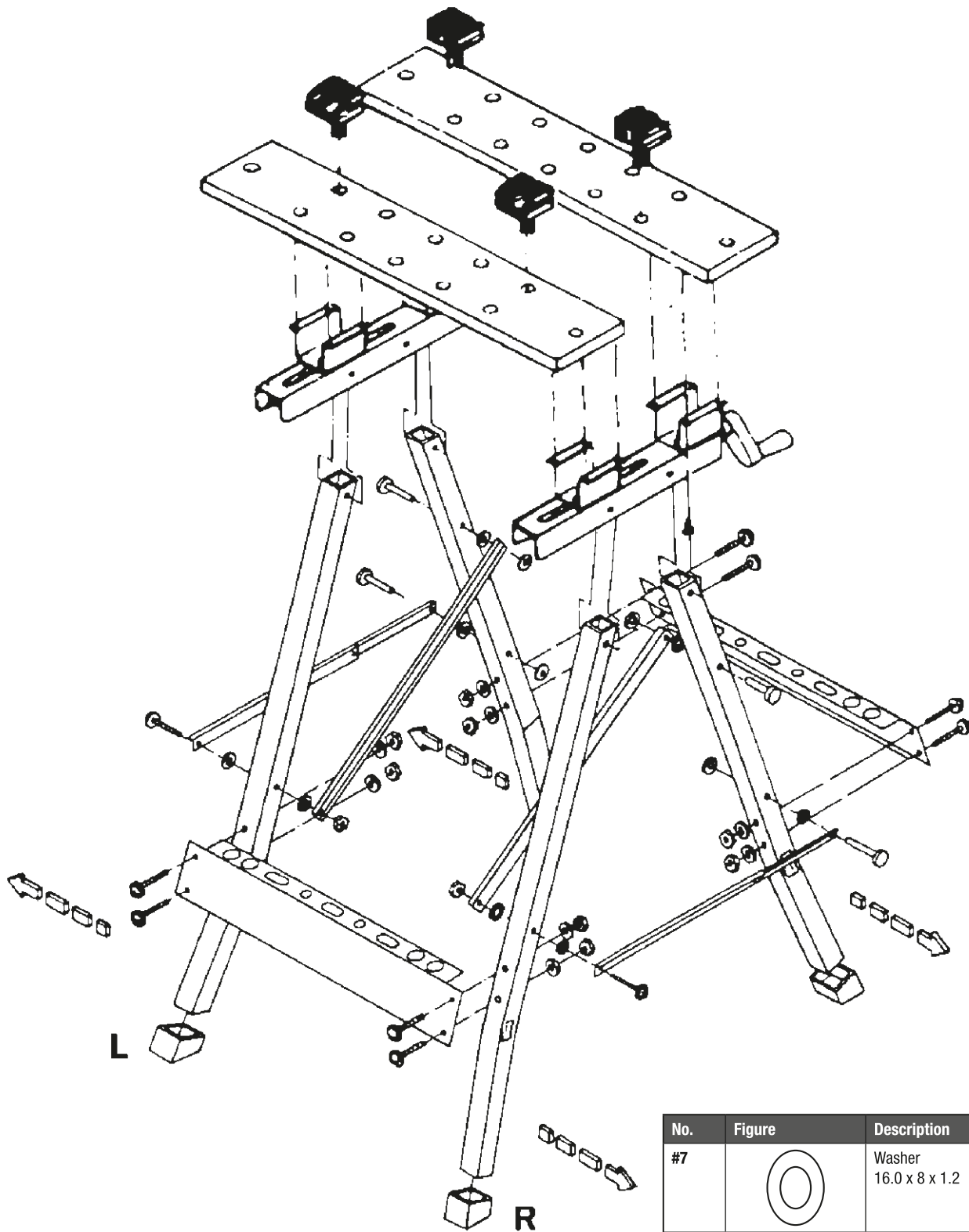

No.	Figure	Description	Quantity
#1		Table top	2 items
#2		Slide	2 items
#3		Bolt (hex.)	4 items
#4		Cross-bar	2 items
#5		Table leg	2 items
#6		Plastic foot	4 items

No.	Figure	Description	Quantity
#7		Washer 16.0 x 8 x 1.2	4 items
#8		Wood screw 4.8 x 16 mm	16 items
#9		Bolt (Phillips) M6 x PH1 x 37 mm	8 items
#10		Nut M6 x P1	8 items
#11		Nut M8 x P1.2	4 items
#12		Chock	4 items
#13		Washer 13 x 6 x 1.2	8 items

NL Werk- en spantafel

Montagehandleiding

meister 



AANWIJZING:

- Zorg voor een vlakke en stevige ondergrond!
- Beveilig de werktafel tegen wegglijden!

Let op!

Bij uitstekende werkstukken bestaat gevaar voor kantelen!

BELANGRIJK

Bewaar deze handleiding voor toekomstig gebruik!

Lees de handleiding zorgvuldig door!

Voor elk gebruik moet de werkbank worden gecontroleerd op schade!



Nr. 9079100

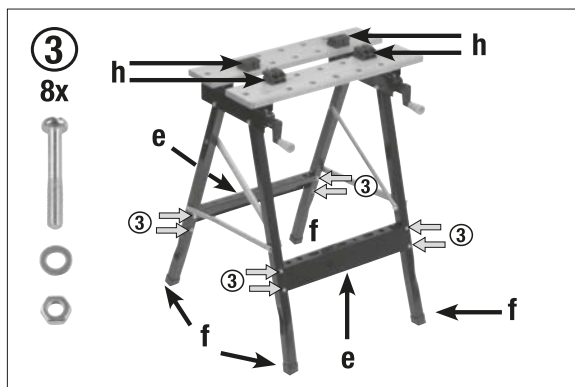
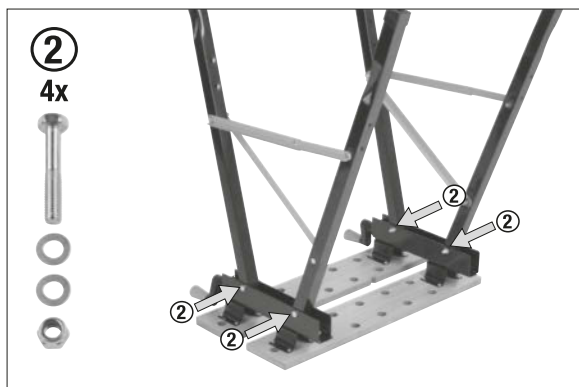
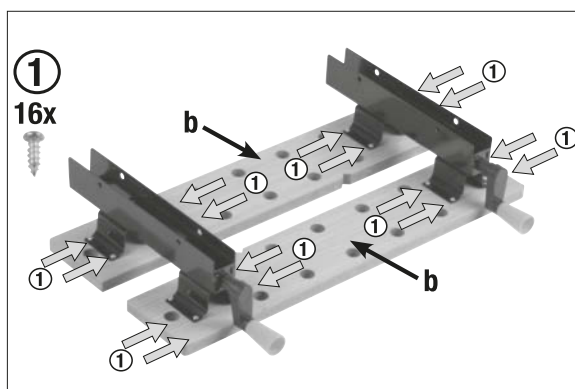
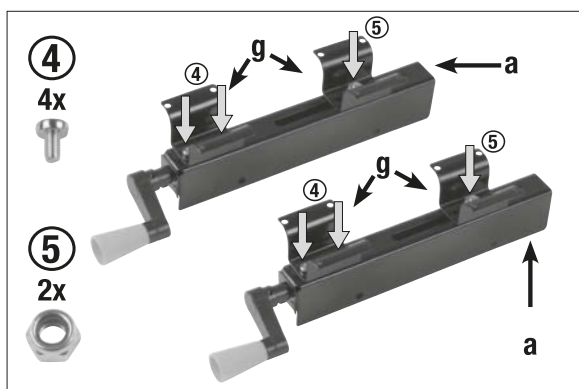
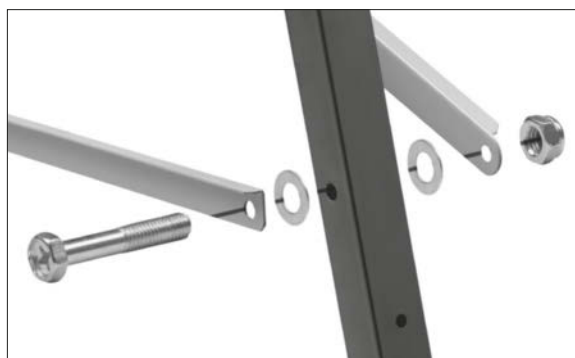
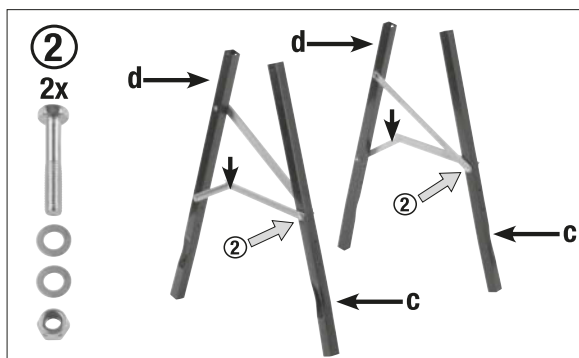
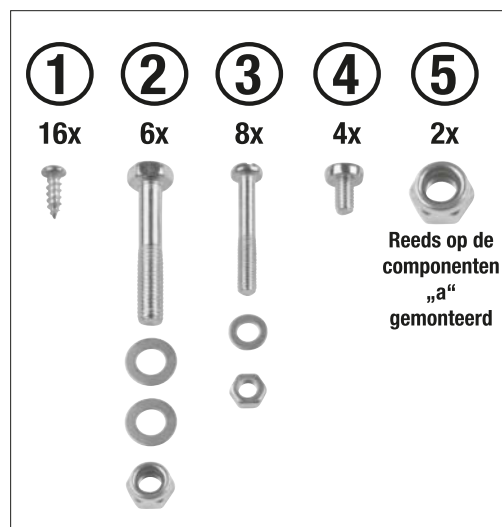
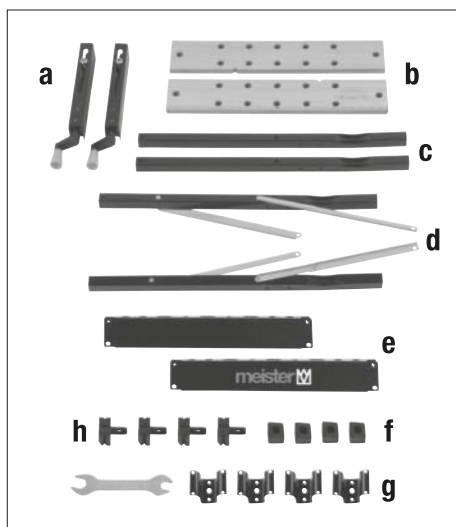

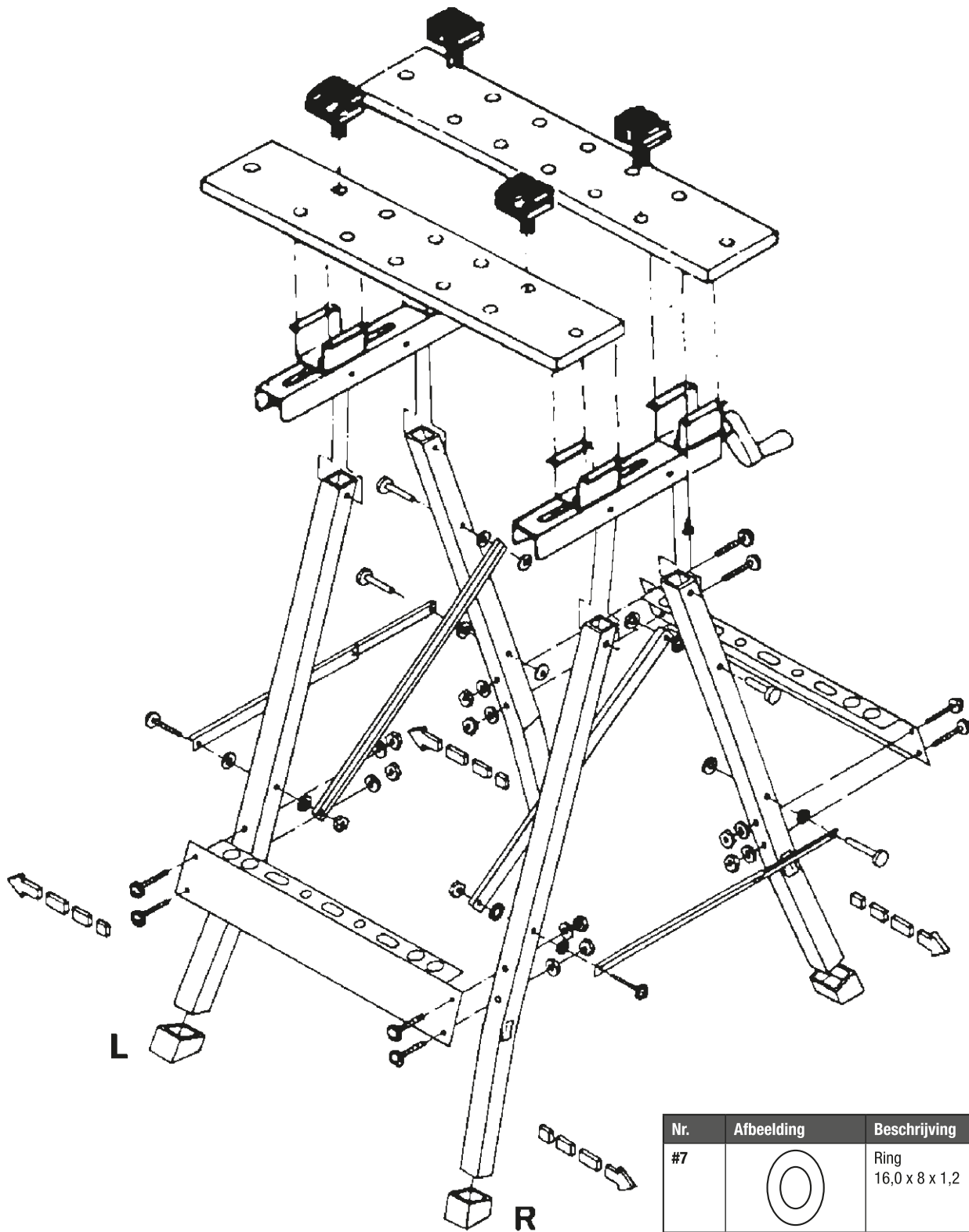

Nr.	Afbeelding	Beschrijving	Aantal
#1		Werkblad	2 stuks
#2		Schuifblok	2 stuks
#3		Bout (hex.)	4 stuks
#4		Dwarsbalk	2 stuks
#5		Staander	2 stuks
#6		Kunststof voet	4 stuks

Nr.	Afbeelding	Beschrijving	Aantal
#7		Ring 16,0 x 8 x 1,2	4 stuks
#8		Houtschroef 4,8 x 16 mm	16 stuks
#9		Bout (Phillips) M6 x PH1 x 37 mm	8 stuks
#10		Moer M6 x P1	8 stuks
#11		Moer M8 x P1,2	4 stuks
#12		Klemsteun	4 stuks
#13		Ring 13 x 6 x 1,2	8 stuks

PL Warsztatowy stół montażowy

Instrukcja montażu

meister 



WSKAZÓWKA:

- Zwracać uwagę na płaskie i stabilne podłoże!
- Zabezpieczyć blat roboczy przed przesuwaniem!

Uwaga!

Ryzyko przewrócenia z powodu pozostawionych obrabianych przedmiotów!

WAŻNA WSKAZÓWKA!

Przechowywać do późniejszego wglądu!

Należy dokładnie przeczytać instrukcję!

Przed każdym użyciem należy sprawdzić stół warsztatowy pod kątem możliwych uszkodzeń!



Nr. 9079100

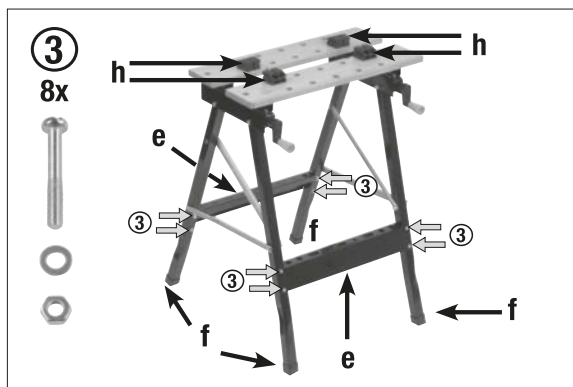
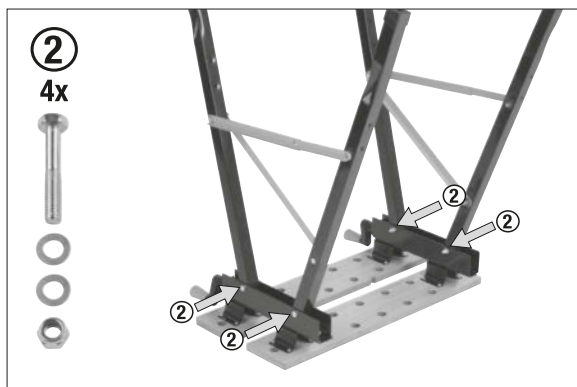
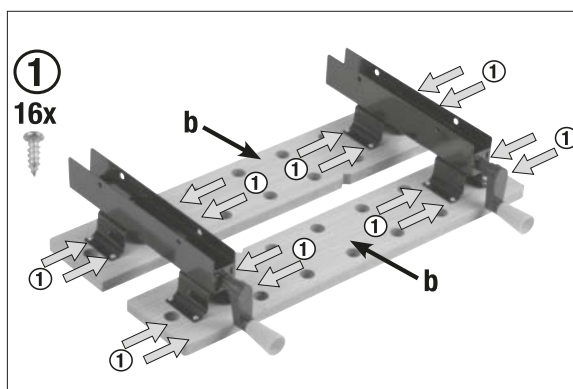
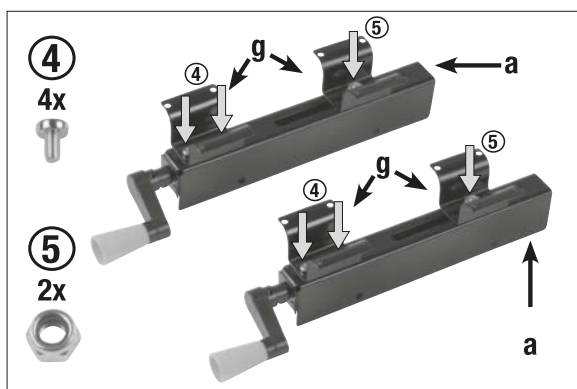
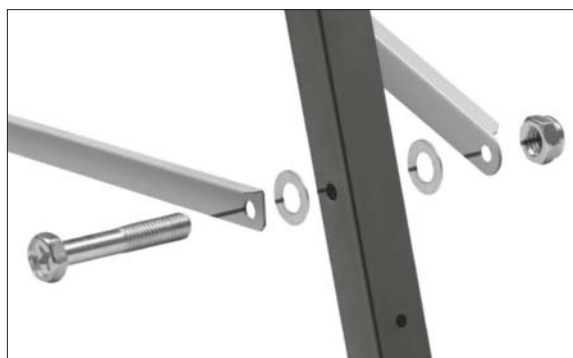
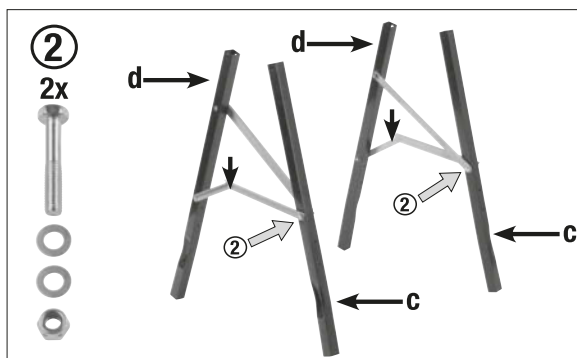
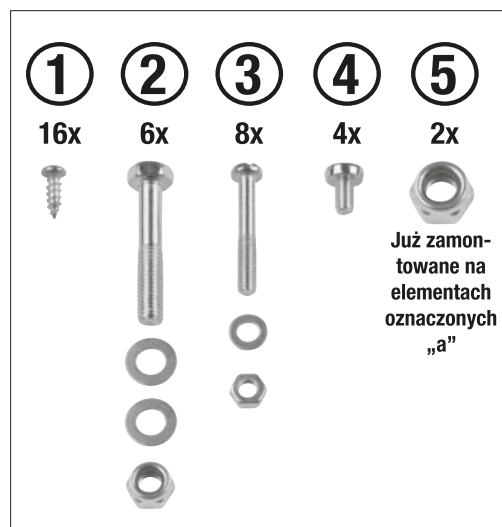
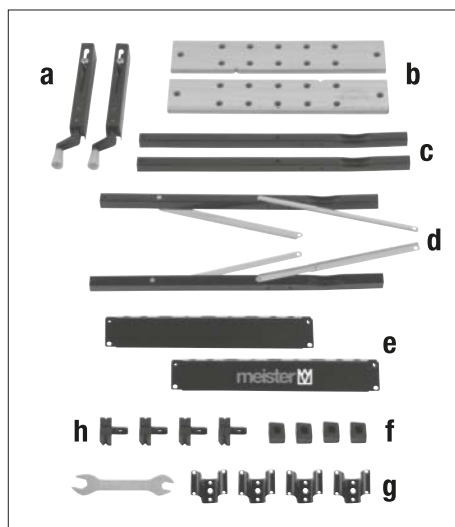

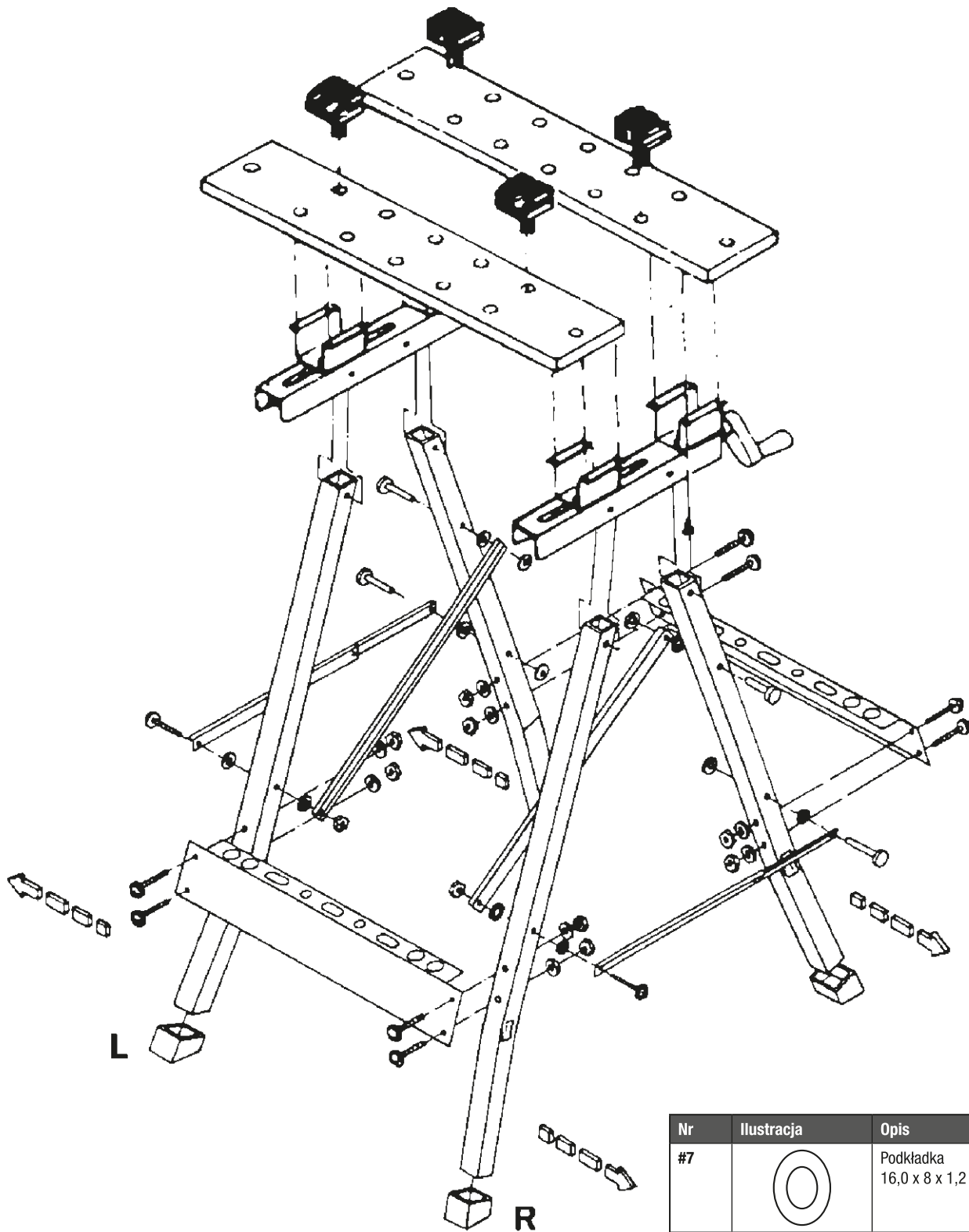

Nr	Ilustracja	Opis	Liczba
#1		Blat stołu	2 sztuki
#2		Wpust przesuwny	2 sztuki
#3		Sworzeń (sześć.)	4 sztuki
#4		Poprzeczka	2 sztuki
#5		Noga stołowa	2 sztuki
#6		Nóżka z tworzywa sztucznego	4 sztuki

Nr	Ilustracja	Opis	Liczba
#7		Podkładka 16,0 x 8 x 1,2	4 sztuki
#8		Wkręt do drewna 4,8 x 16 mm	16 sztuki
#9		Sworzeń (Phillips) M6 x PH1 x 37 mm	8 sztuki
#10		Nakrętka M6 x P1	8 sztuki
#11		Nakrętka M8 x P1,2	4 sztuki
#12		Klin	4 sztuki
#13		Podkładka 13 x 6 x 1,2	8 sztuki

TR İş tezgâhı ve tutturma tezgâhı Montaj tâlimatı

meister 



AÇIKLAMA:

- Zeminin düz ve sağlam olmasına dikkat edin!
- Tezgâhı kaymaya karşı emniyete alın!

Dikkat!

Çıkmış duran malzemelerde devrilme tehlikesi vardır!

ÖNEMLİ

İleride bakmak üzere saklayın!

Kullanma kılavuzunu dikkatle okuyun!

İş tezgâhı her kullanımdan önce hasar olup olmadığı açısından kontrol edilmelidir!



Nr. 9079100

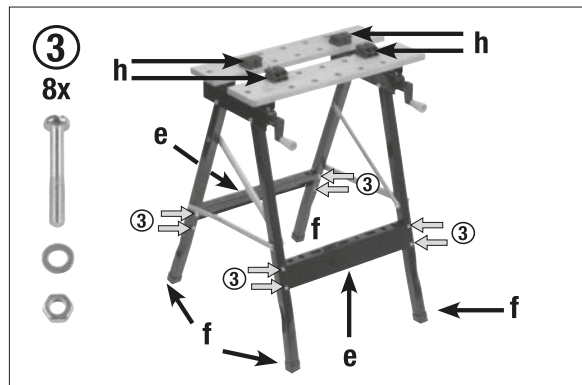
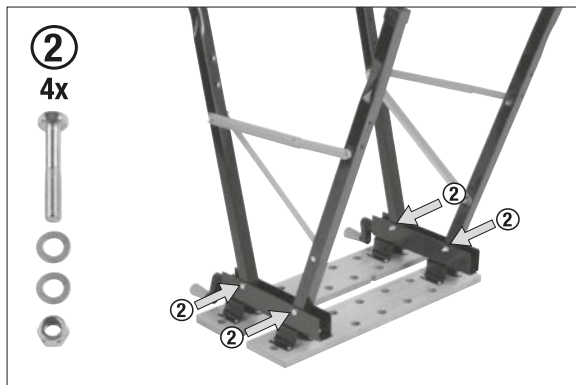
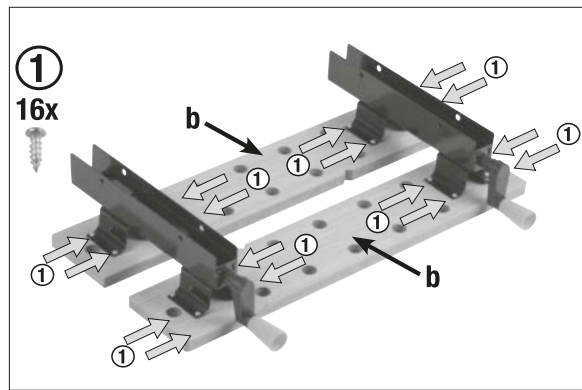
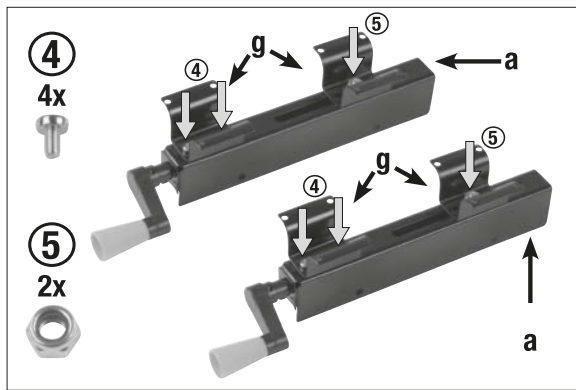
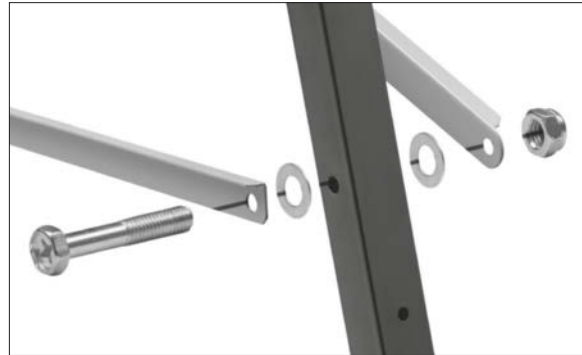
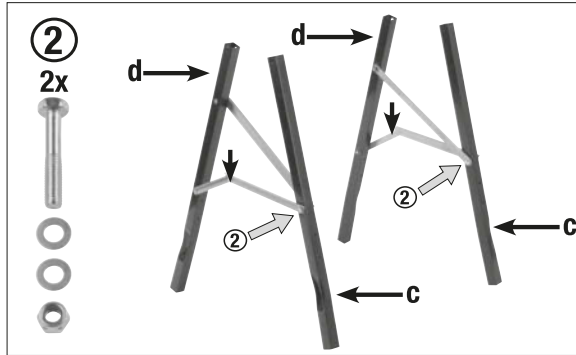
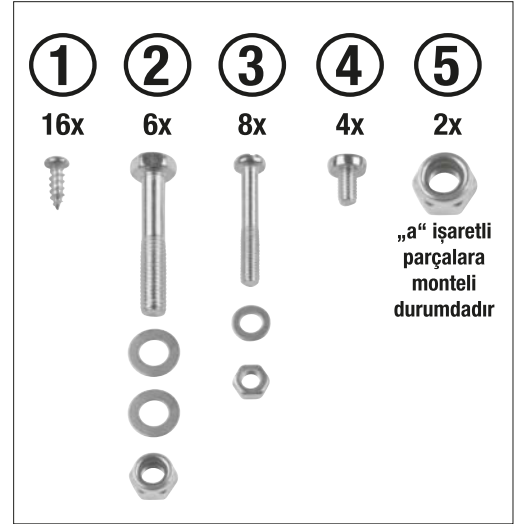
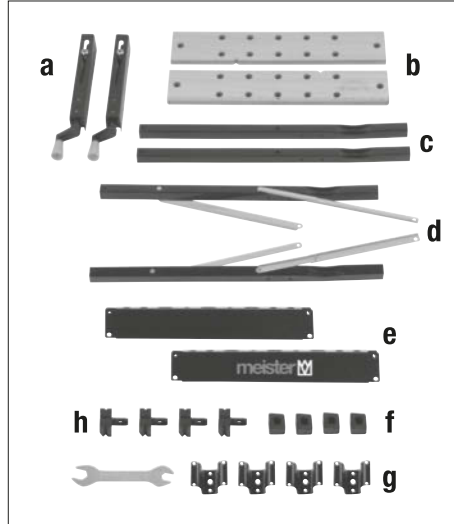

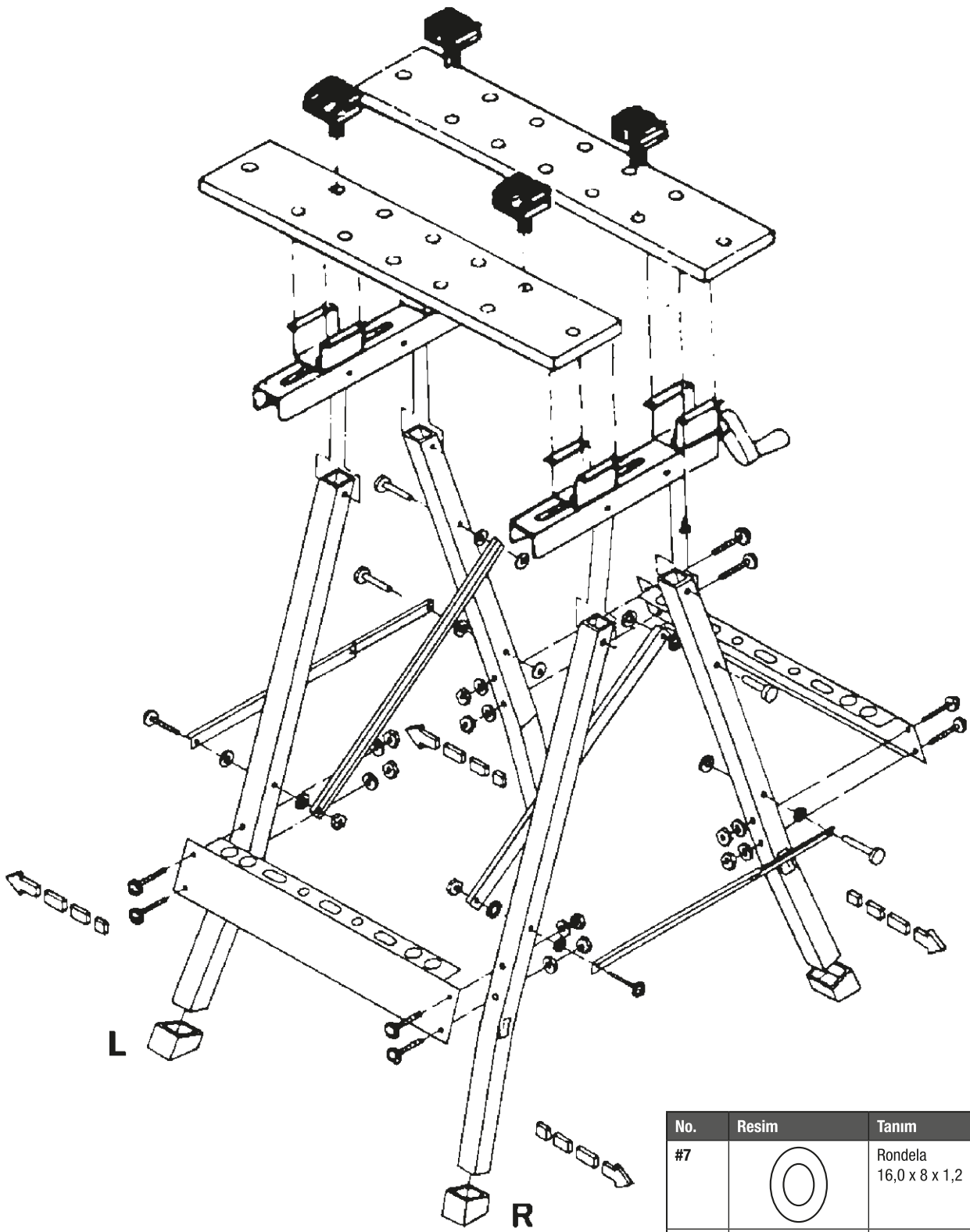

No.	Resim	Tanım	Adet
#1		Tezgâh tahtası	2 adet
#2		Kızak	2 adet
#3		Cıvata (altıgen)	4 adet
#4		Çubuk	2 adet
#5		Masa ayağı	2 adet
#6		Plastik ayak	4 adet

No.	Resim	Tanım	Adet
#7		Rondela 16,0 x 8 x 1,2	4 adet
#8		Ağaç vidası 4,8 x 16 mm	16 adet
#9		Cıvata (Phillips) M6 x PH1 x 37 mm	8 adet
#10		Somun M6 x P1	8 adet
#11		Somun M8 x P1,2	4 adet
#12		Kama	4 adet
#13		Rondela 13 x 6 x 1,2	8 adet

Service:

Conmetall Meister GmbH

Kundenservice

Warenannahme Tor 3
Oberkamper Straße 39
42349 Wuppertal

Telefon: +49 (0) 202 / 24750 430
+49 (0) 202 / 24750 431
+49 (0) 202 / 24750 432

Fax: +49 (0) 202 / 6 98 05 88

E-Mail: meister-service@conmetallmeister.de

© Copyright
Nachdruck oder Vervielfältigung – auch auszugsweise – nur mit Genehmigung der

Conmetall Meister GmbH
Hafenstraße 26
29223 Celle • GERMANY
www.conmetallmeister.de

2018/2019

Diese Druckschrift einschließlich aller ihrer Teile ist urheberrechtlich geschützt.
Jede Verwertung außerhalb der engen Grenzen des Urheberrechtsgesetzes ist ohne Zustimmung der
Conmetall Meister GmbH unzulässig und strafbar. Das gilt insbesondere für Vervielfältigungen,
Übersetzungen, Mikroverfilmungen und die Einspeisung und Verarbeitung in elektronischen Systemen.