

- |           |                                    |           |                                 |
|-----------|------------------------------------|-----------|---------------------------------|
| <b>D</b>  | <b>Montageanleitung</b>            | <b>GB</b> | <b>Assembly Instructions</b>    |
| <b>FR</b> | <b>Notice de montage</b>           | <b>IT</b> | <b>Istruzioni di montaggio</b>  |
| <b>NL</b> | <b>Handleiding voor de montage</b> | <b>PL</b> | <b>Instrukcja montażu</b>       |
| <b>CZ</b> | <b>Montážní návod</b>              | <b>SK</b> | <b>Návod na montáž</b>          |
| <b>HU</b> | <b>Szerelési útmutató</b>          | <b>RO</b> | <b>Instrukțiunile de montaj</b> |
| <b>TR</b> | <b>Montaj talimatı</b>             | <b>RU</b> | <b>Инструкция по монтажу</b>    |

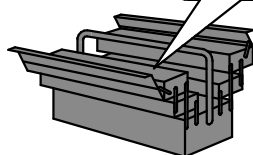
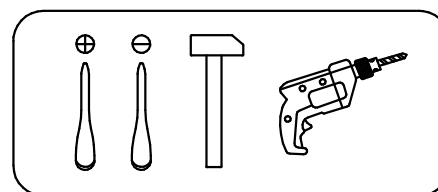
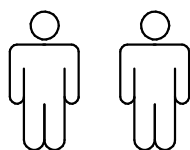

0  
10  
20  
30  
40  
50  
60  
70  
80  
90  
100  
110  
120  
130  
140  
150  
160  
170  
180  
190  
200

Service · Dienstverlening · Serwis · Servis · Сервисная служба

Name · Naam · Nazwa · İsim · Название

Nr. · No. · Номер

Typ · Type · Tip · Тип

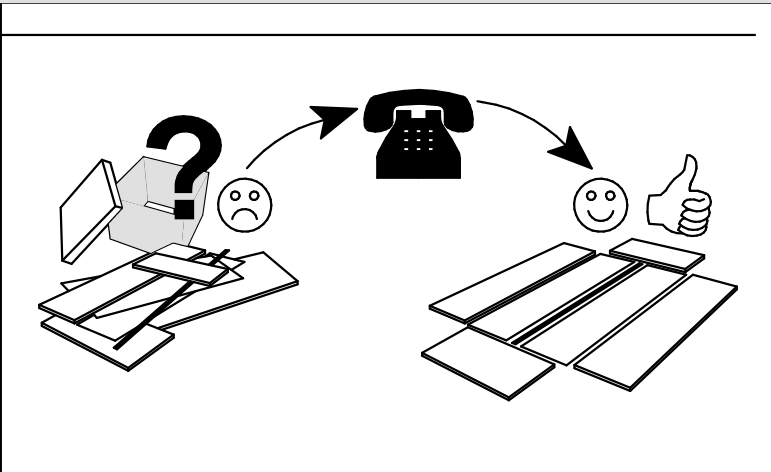
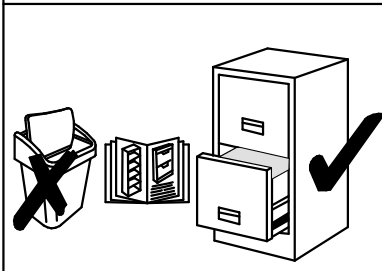

A 1 8×30 x20	B 1 15×9.5 x32	C 1 7×24 x32	D 30 3.5×15 x7	D 17 3.0×20 x34
D 47 3.5×35 x14	D 91 4.0×60 x1	D 201 4.2×19 x8	E 41 x10	G 191 x2
H 125 x3	H 79 x3	L 40 x4	M 1 x12	N 2 8×50 x1
N 41 77×32 x1	P 41 6.3×11 x8	P 62 7×50 x8	S 29 S 36 x6	X 47 x1
D 61 x4	Z 87 x1			

N	Size/MaB (mm)	Qty	✓	N	Size/MaB (mm)	Qty	✓
1	400×410	1		10	396×110	1	
2	400×390	1		11	922×364	1	
3	1660×390	1		12	150×30	3	
4	1660×390	1		13	386×315	1	
5	150×110	4		14	1005×386	1	
6	368×385	2		15	386×355	1	
7	347×337	2		16	396×175	2	
8	360×377	2		17	350×115	2	
9	396×346	1		18	350×115	2	
				19	326×115	2	

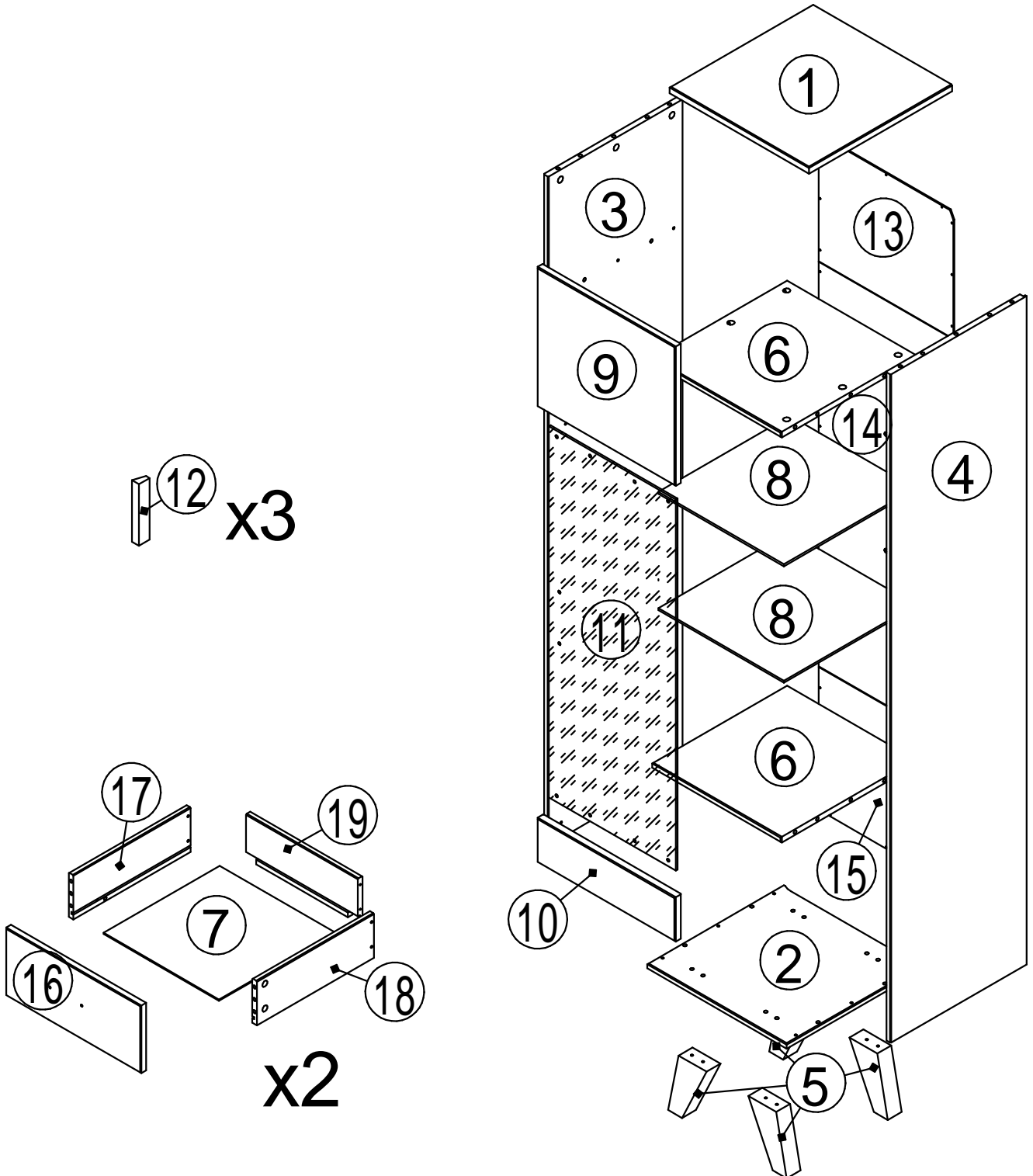
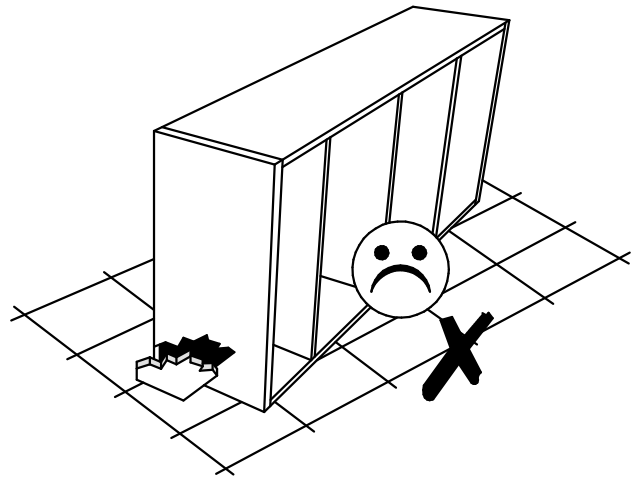
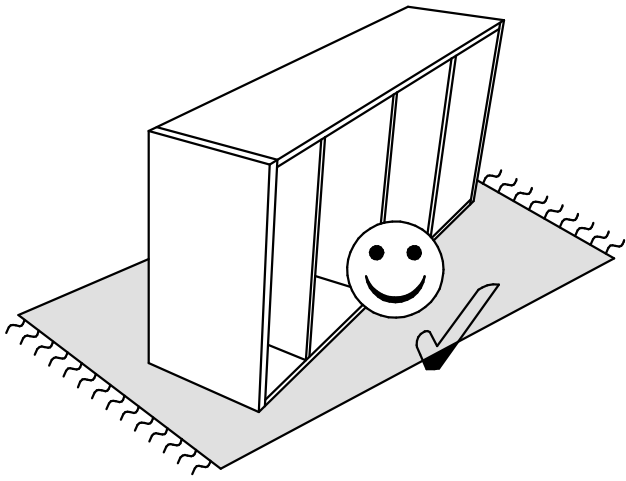

1

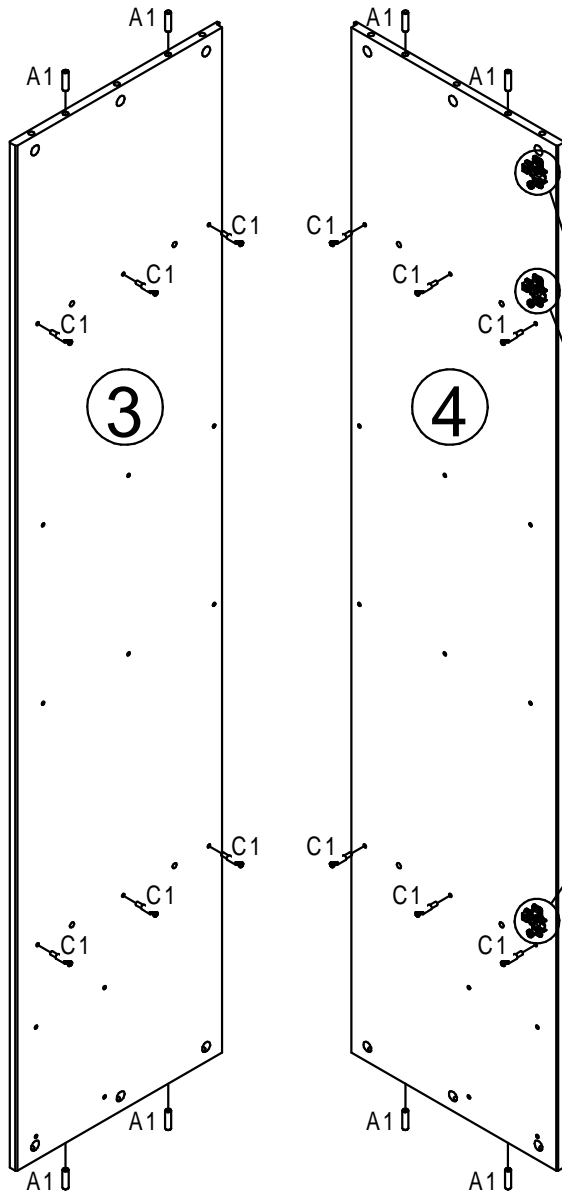



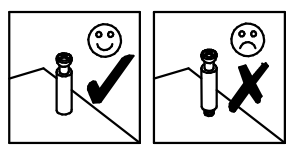
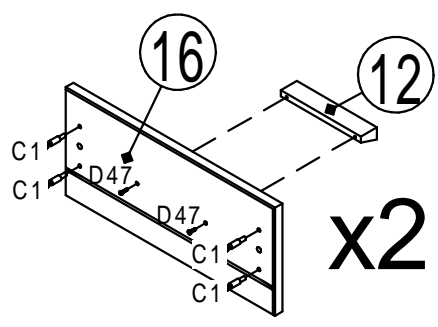
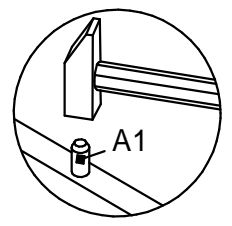
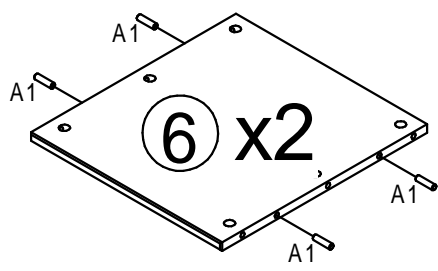
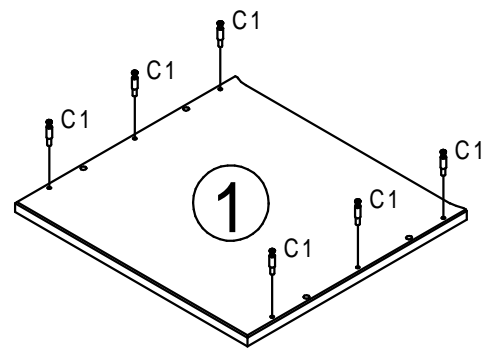
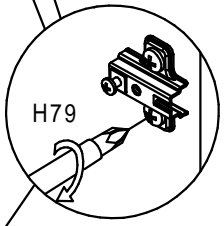

- A 1 8x30 x16
- C 1 7x24 x26
- D 47 3.5x35 x4
- H 79 x3

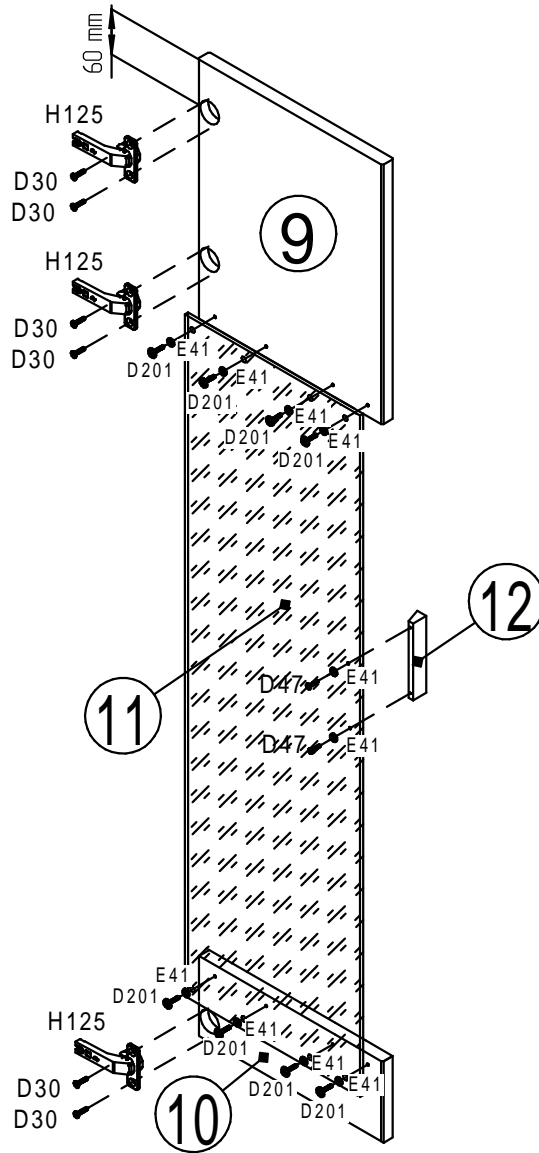

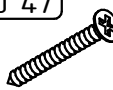

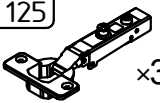

2



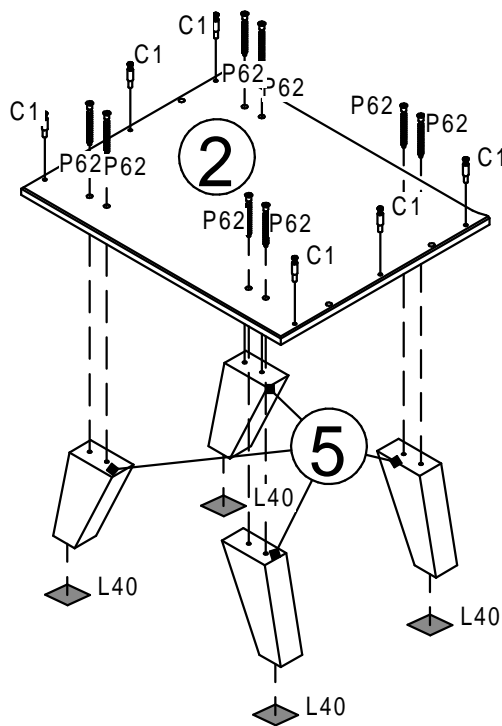

- D 47** 3.5x35  
 x2
- D 30** 3.5x15  
 x6
- H 125**  
 x3
- E 41**  
 x10
- D 201** 4.2x19  
 x8

3



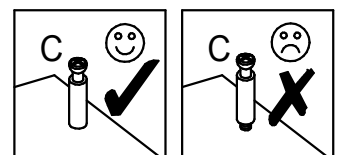
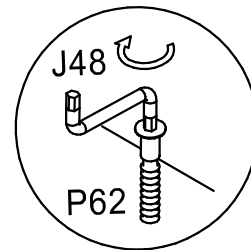

- C 1** 7x24  
 x6
- L 40**  
 x4
- P 62** 7x50  
 x8

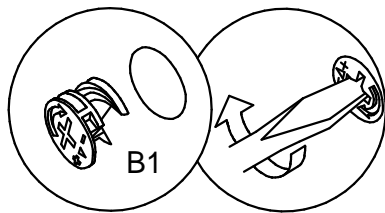
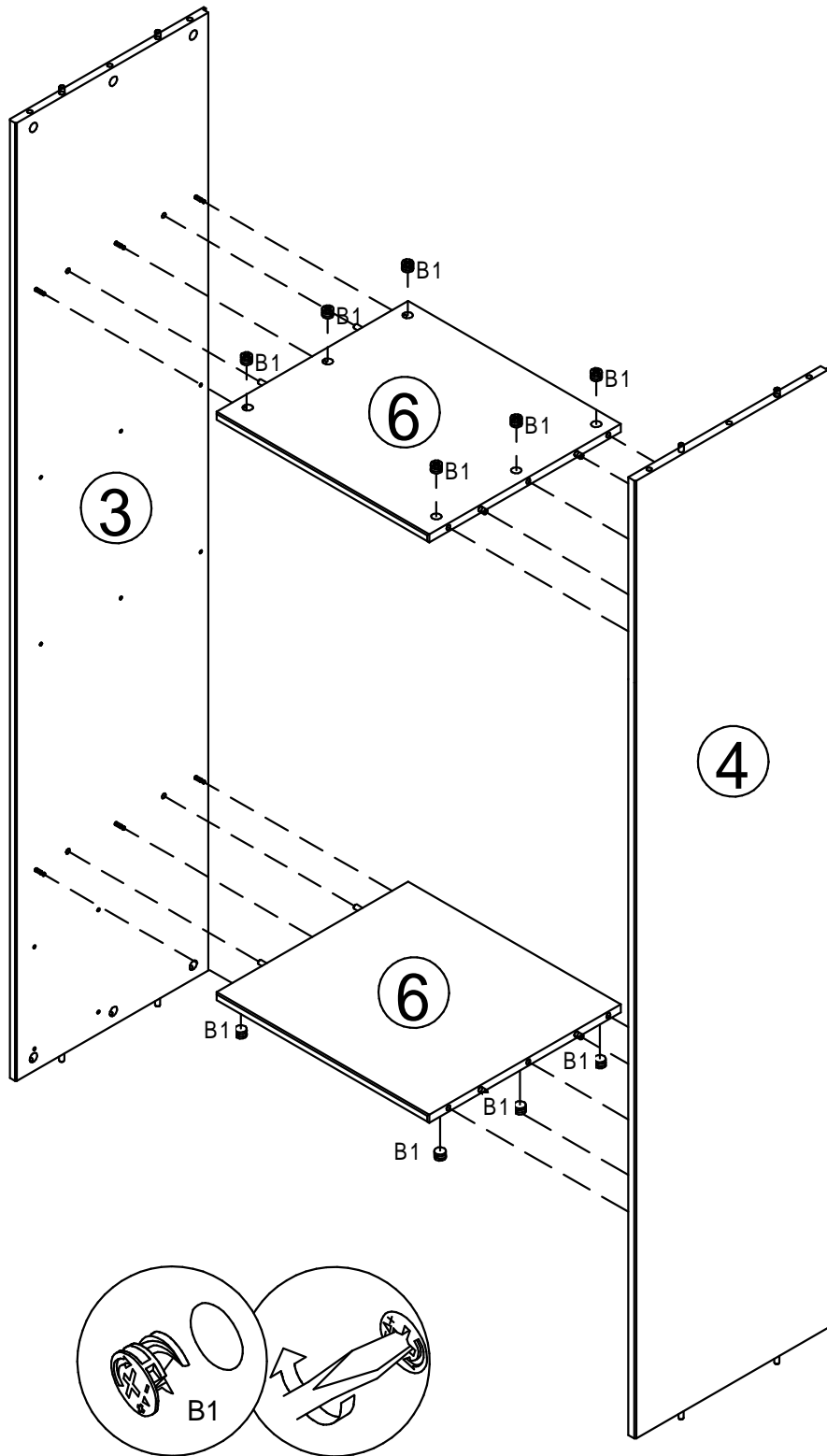

B 1	15x9.5
	x12



B 1	15x9.5
	x12

S 29	
S 36	
	x6

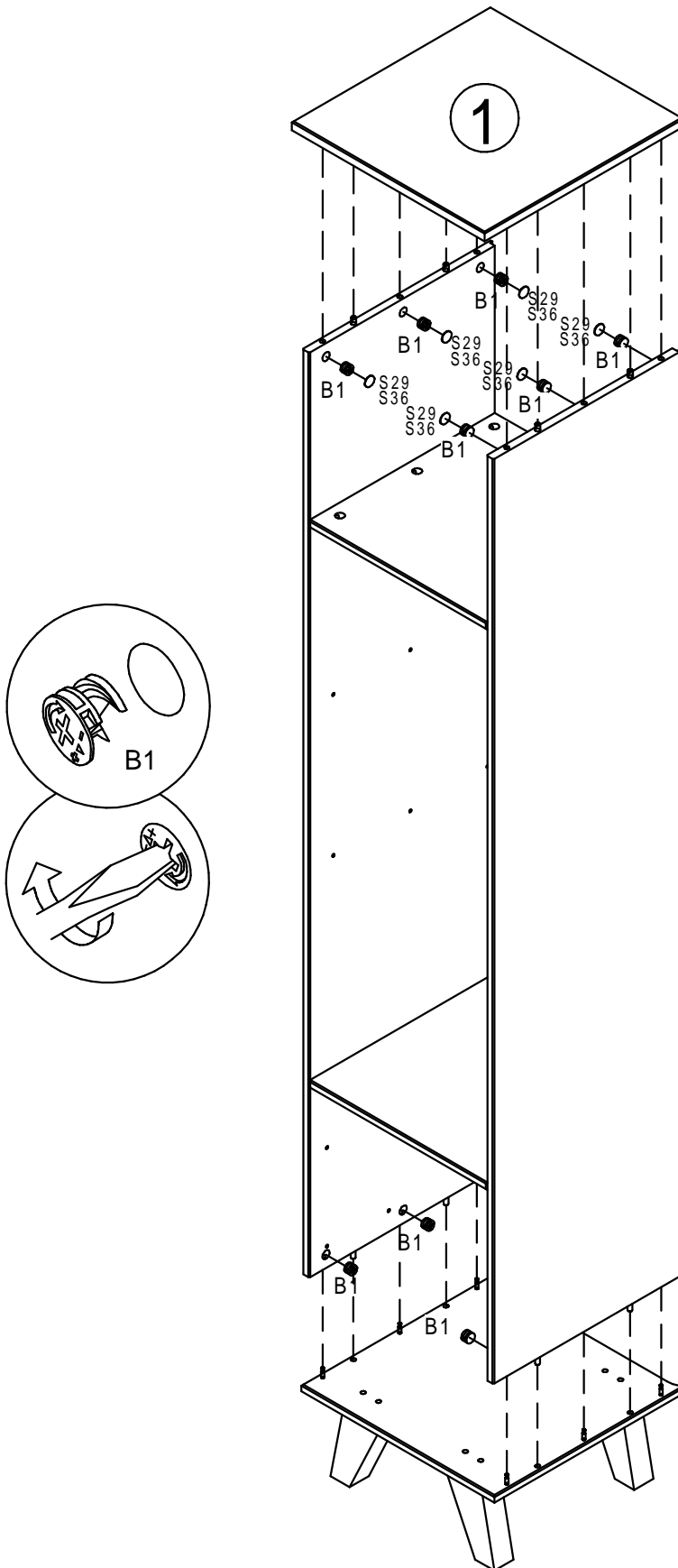

6

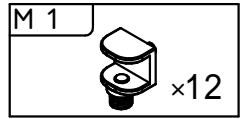
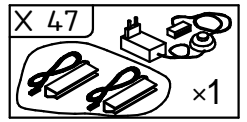
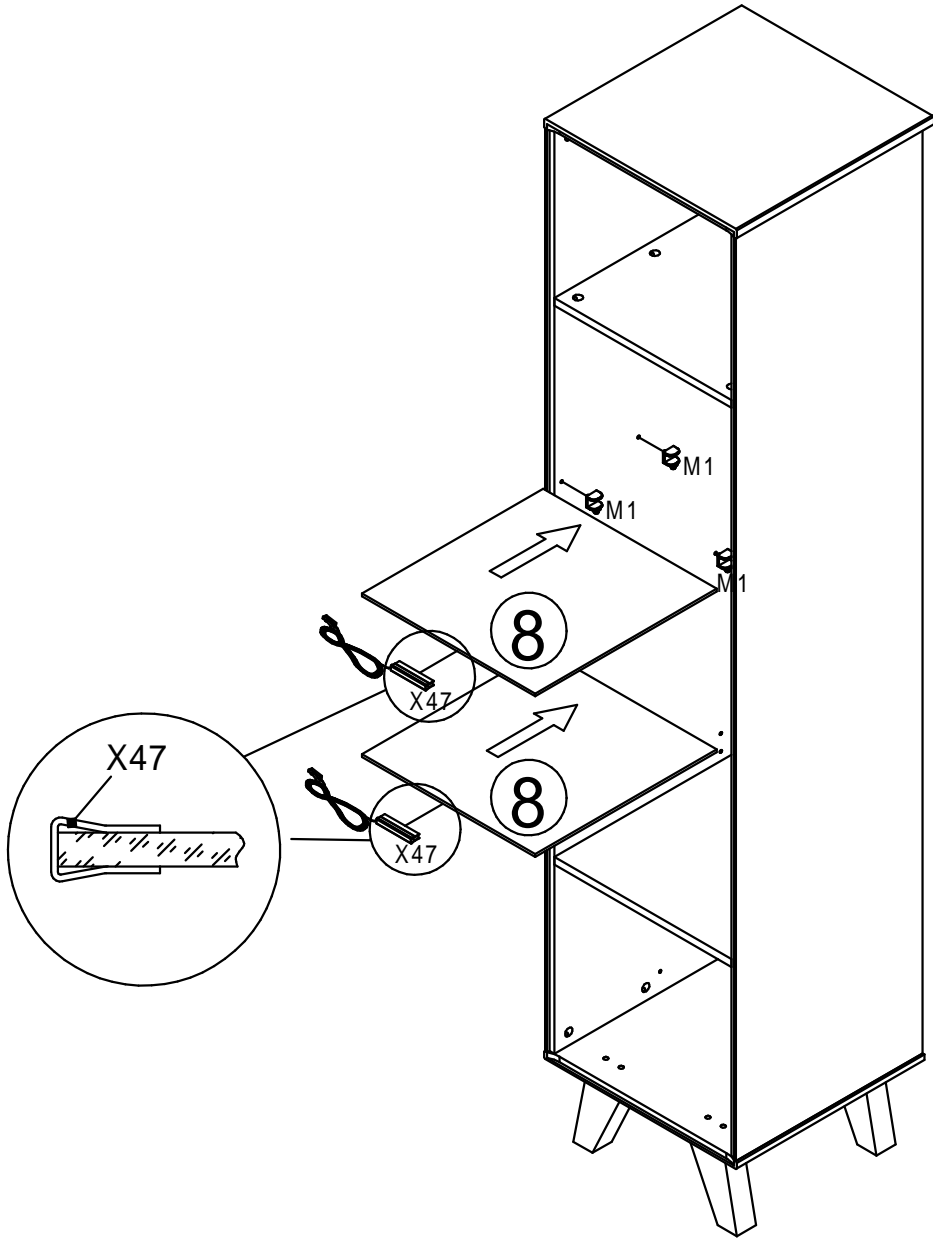

7

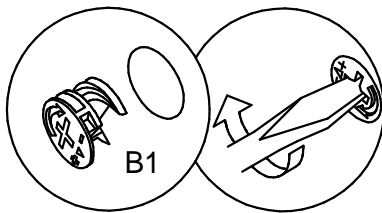
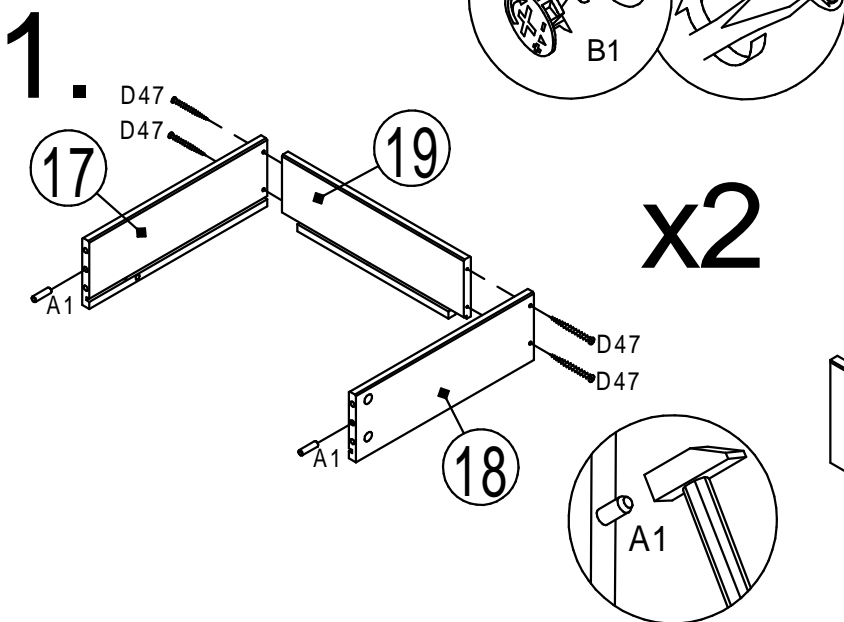

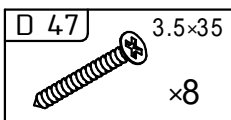
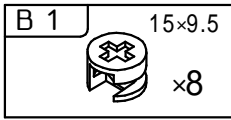
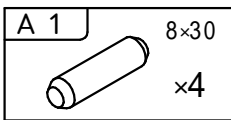
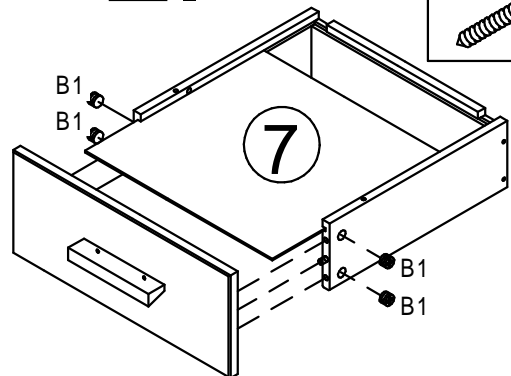

x2

2.







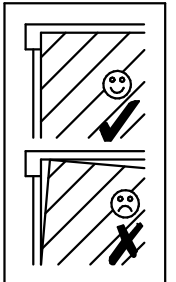
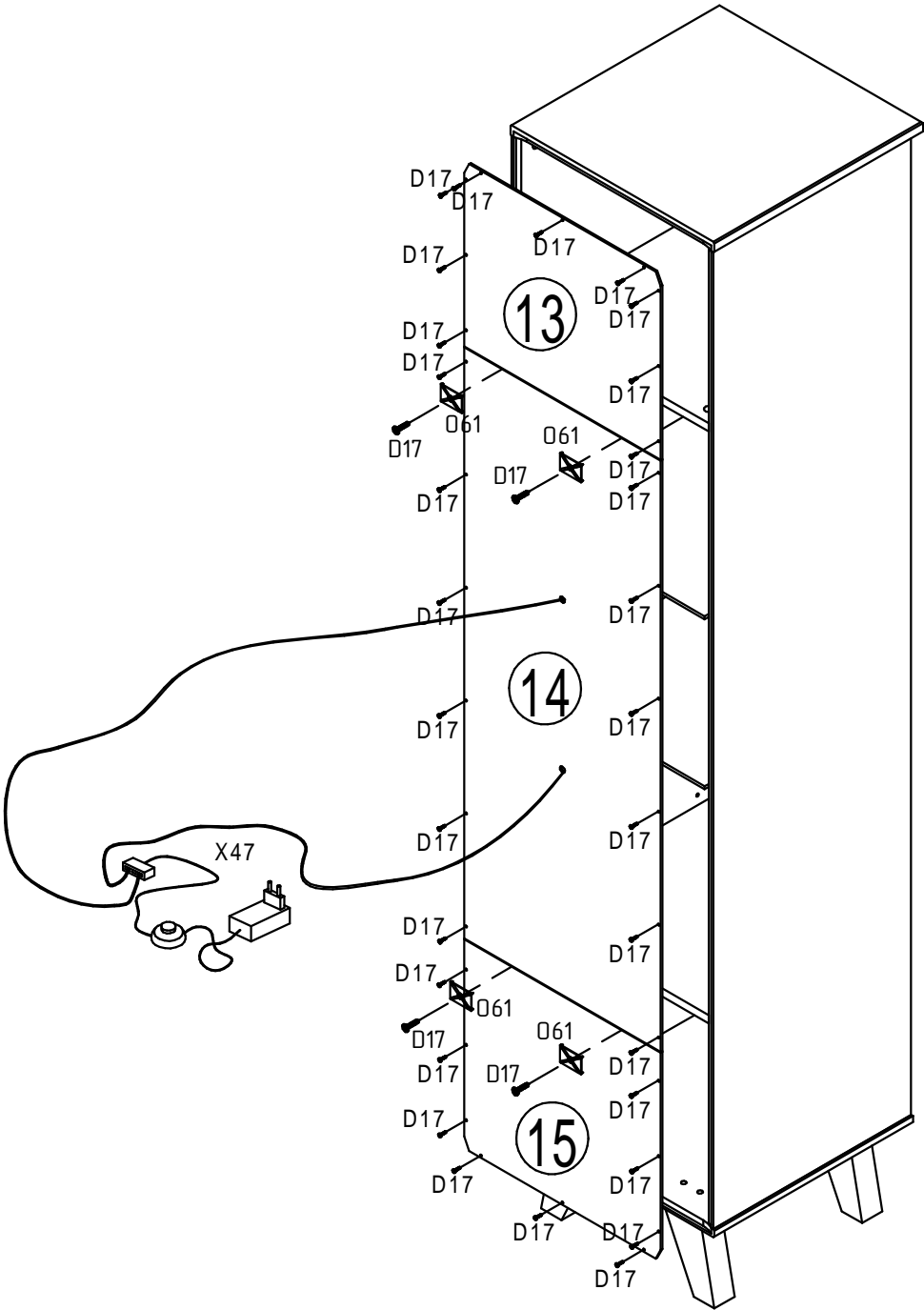

D 17 3.0x20  
  
 x34

O 61  
  
 x4

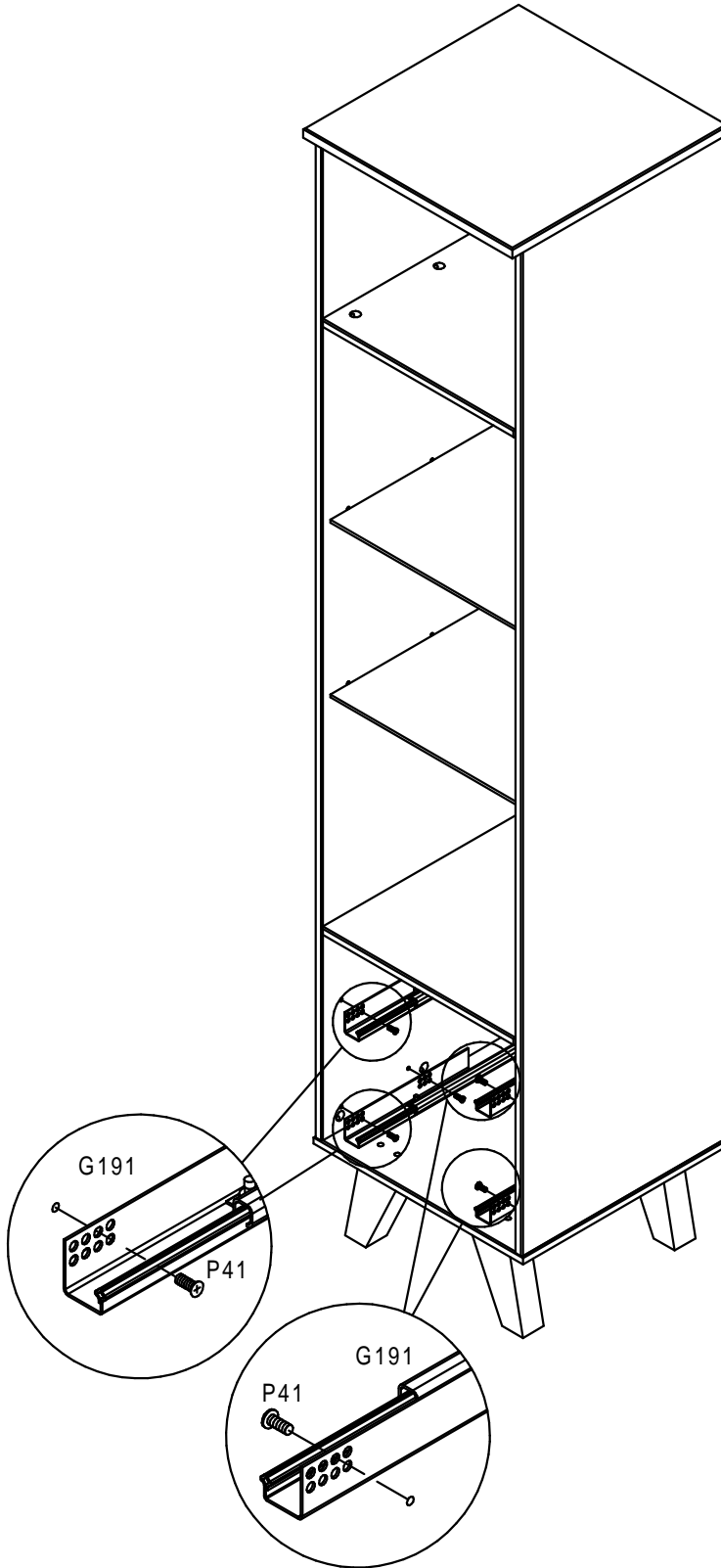
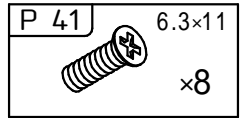
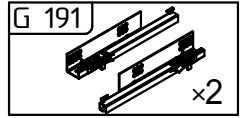
X 47  
  
 x1

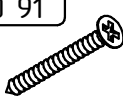

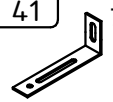

D 91	4.0x60	D 30	3.5x15
	x1		x1
Z 87		N 2	8x50
	x1		x1
		N 41	77x32
			x1

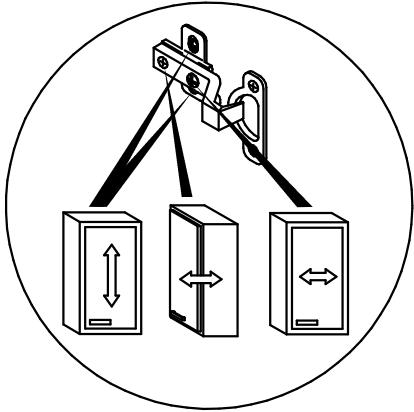
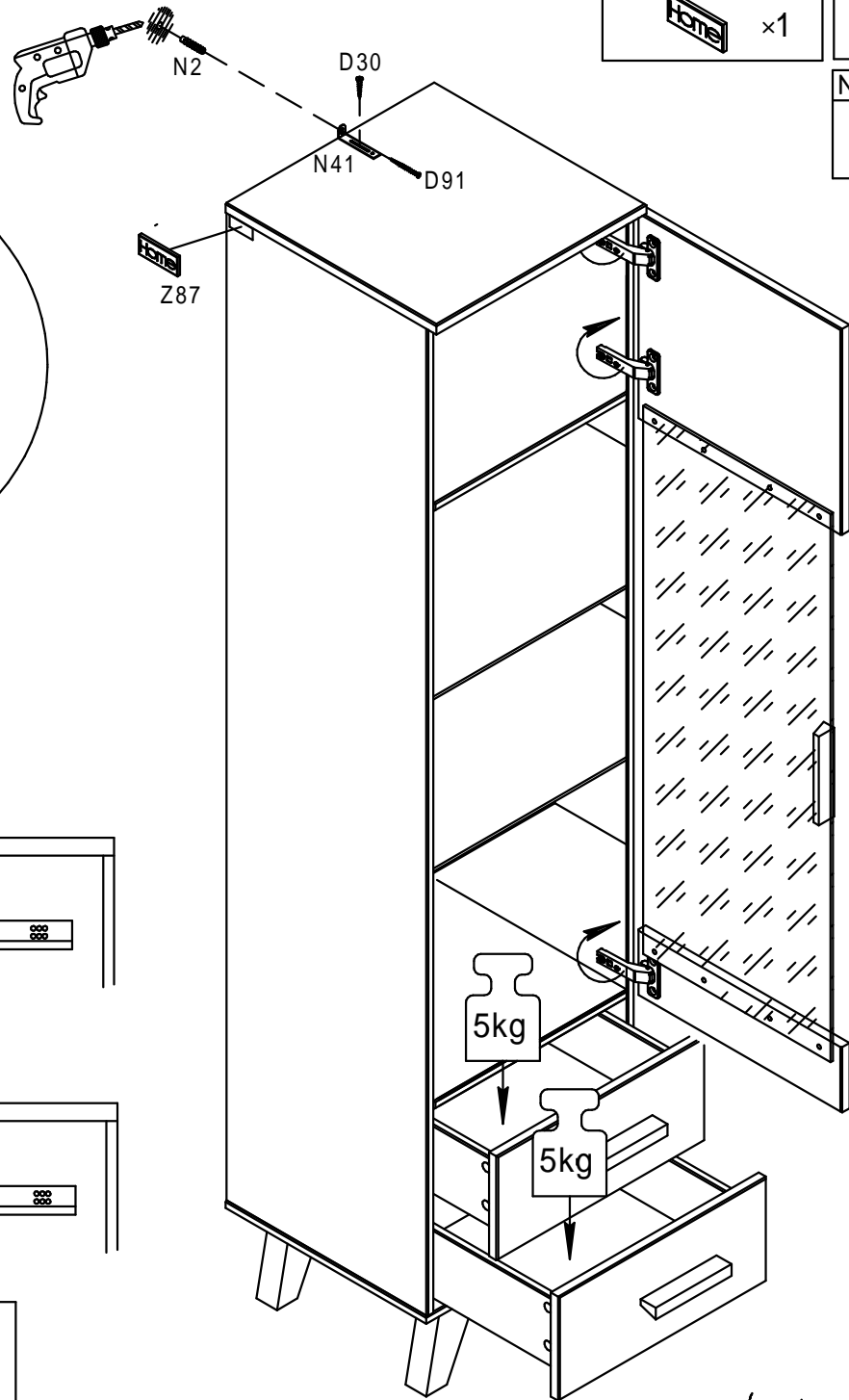

1)

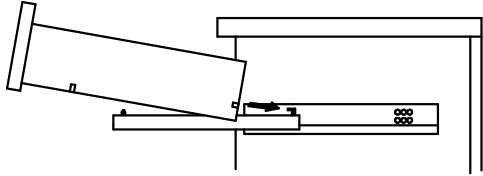

2)

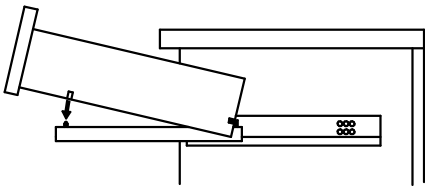

3)

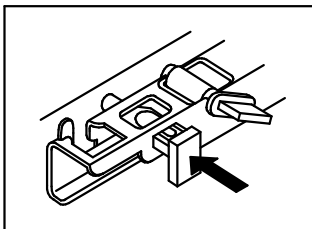

4)

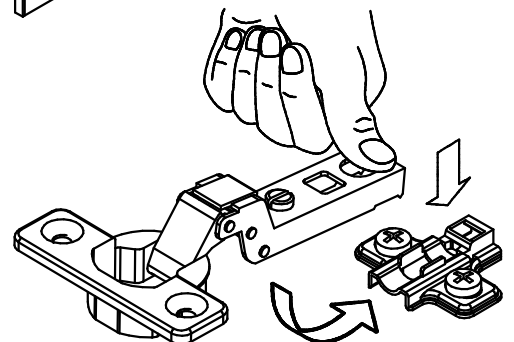
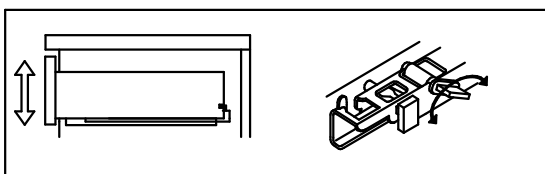

**Achtung • Attention • Attenzione  
Opgelet • Uwaga • Pozor • Figyelem  
Atenție • Dikkat • Внимание**



<b>(D)</b>	Wandbefestigung dient als Kippschutz – unbedingt anbringen! Bei einigen Wandtypen kann ein Spezialdübel erforderlich sein!
<b>(GB)</b>	The wall fastening serves to prevent tipping – be absolutely sure to mount it! For certain wall types, a special wall plug may be necessary!
<b>(FR)</b>	La fixation murale sert de protection contre le basculement – à installer impérativement ! Pour certains types de murs il faut des chevilles spéciales !
<b>(IT)</b>	Il fissaggio alla parete serve da protezione anti-ribaltamento – attaccarla assolutamente! Per alcune strutture di parete può essere necessario un tassello speciale!
<b>(NL)</b>	Bevestiging aan de muur dient als kantelbescherming – zeker en vast bevestigen! Bij enkele muurtypes is een speciale plug misschien vereist!
<b>(PL)</b>	Mocowanie do ściany jest jednocześnie zabezpieczeniem przed przewróceniem – koniecznie zamontować! Do niektórych rodzajów ścian koniecznie zastosować specjalne kołki mocujące.
<b>(CZ)</b>	Montáž na stěnu slouží jako ochrana proti převrnutí – bezpodmínečně umístěte! U některých typů stěn může být zapotřebí speciální hmoždinka!
<b>(SK)</b>	Upevnenie na stenu slúži ako ochrana proti prevráteniu – bezpodmienne použite! Pre niektoré druhy stien môže byť potrebná špeciálna hmoždinka!
<b>(HU)</b>	A terméket a falhoz kel rögzíténi, különben az felborulhat! Egyes faltípusoknál speciális tiplit kell használni!
<b>(RO)</b>	Sistemul de fixare la perete servește ca protecție la răsturnare – de montat obligatoriu! Pentru unele tipuri de pereți este posibil să fie necesar un diblu special!
<b>(TR)</b>	Duvardaki sabitleme, devrilmeye karşı bir emniyet tedbiridir ve mutlaka monte edilmelidir! Bazı duvar tiplerinde bunun için özel bir dübel gerekli olabilir!
<b>(RU)</b>	Обязательно установите крепление на стене во избежание опрокидывания! Для некоторых типов стен может потребоваться специальный дюбель!