

# Lisa 26015 / 9943

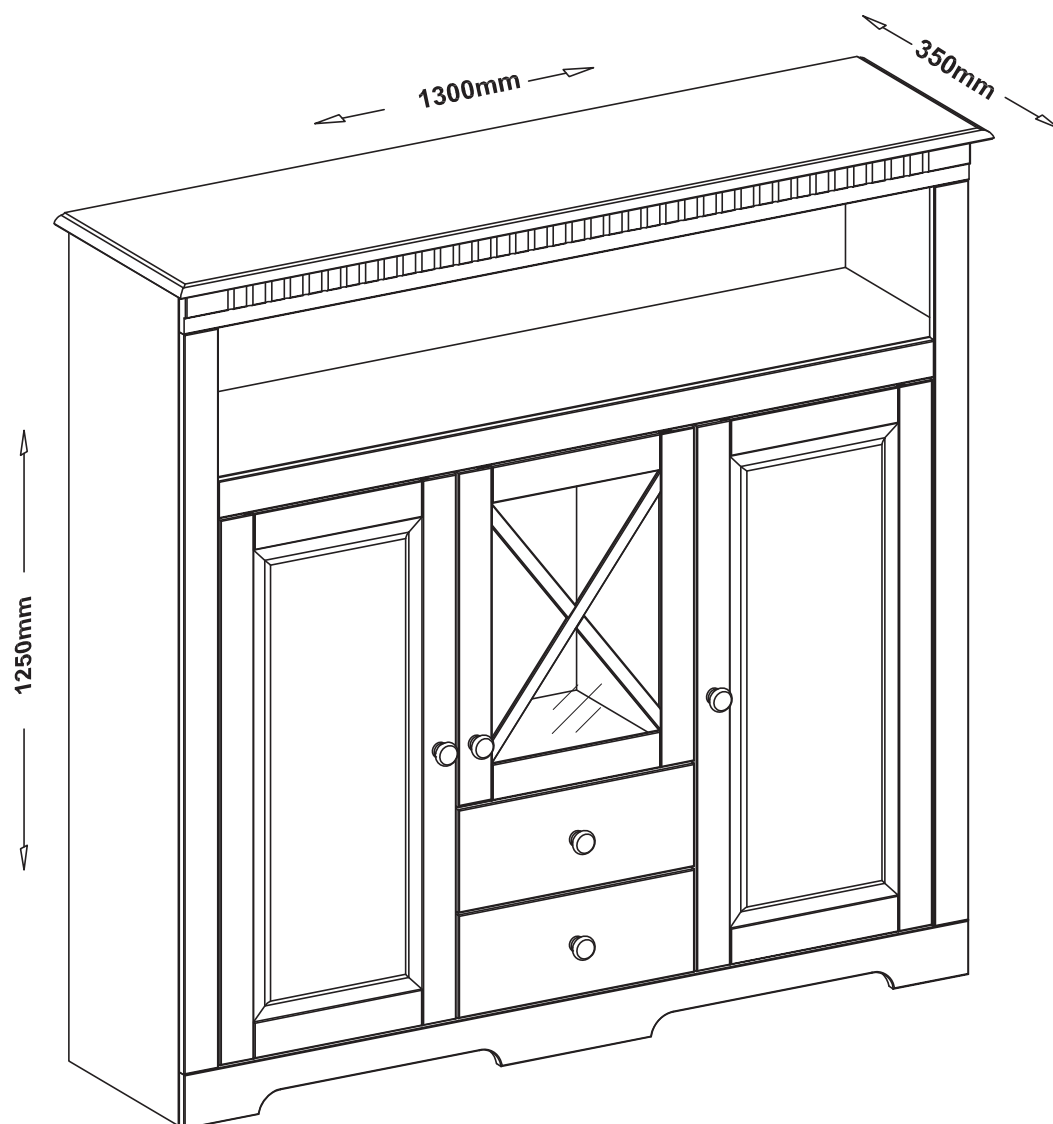

- |   |                                     |
|---|-------------------------------------|
| <b>(D)</b> Montageanleitung             | <b>(GB)</b> Assembly instructions   |
| <b>(FR)</b> Notice de montage           | <b>(IT)</b> Istruzioni di montaggio |
| <b>(NL)</b> Handleiding voor de montage | <b>(PL)</b> Instrukcja montażu      |
| <b>(CZ)</b> Montážní návod              | <b>(SK)</b> Návod na montáž         |
| <b>(HU)</b> Szerelési útmutató          | <b>(RO)</b> Instrucțiuni de montaj  |
| <b>(TR)</b> Montaj talimatı             | <b>(RU)</b> ИНСТРУКЦИЯ ПО МОНТАЖУ   |

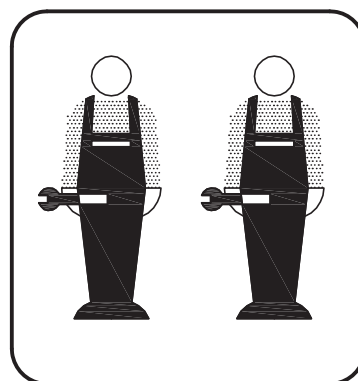
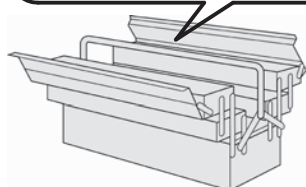
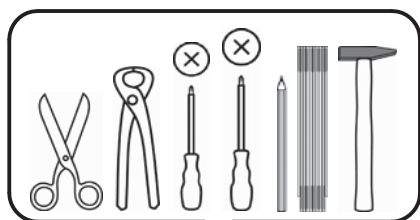

# Service • Assistenza • Dienstverlening • Serwis Servis • Szerviz • Сервисная служба

Name • Nom • Nome • Naam •  
Nazwa • Jméno • Názov • Név •  
Denumire • Ísim • Название

Nr. • No. • N° • Номер • Č • Sz

Typ • Type • Tip • Tipus • Тиро •  
Тип

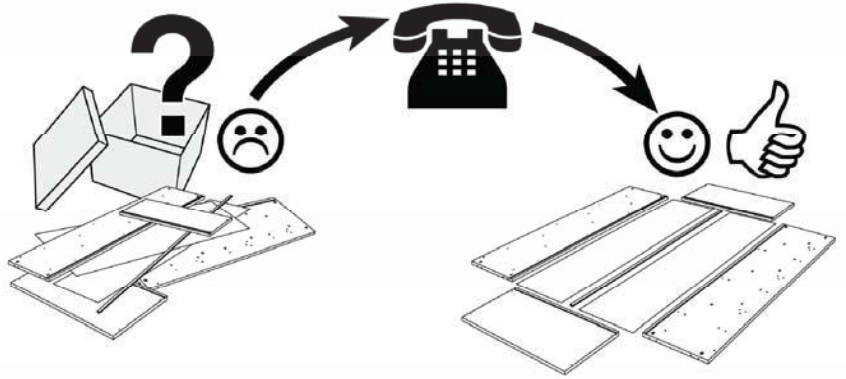
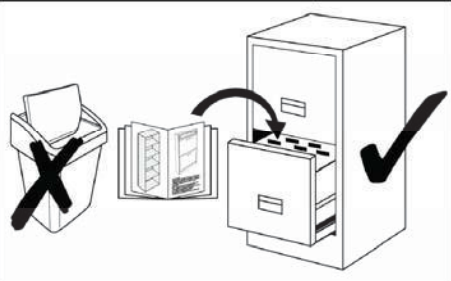

0  
10  
20  
30  
40  
50  
60  
70  
80  
90  
100  
110  
120  
130  
140  
150  
160  
170  
180  
190  
200

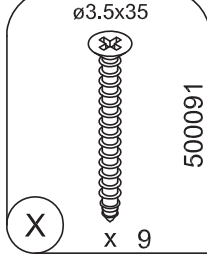
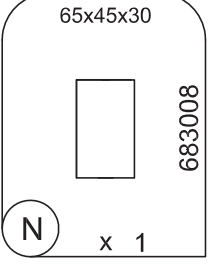
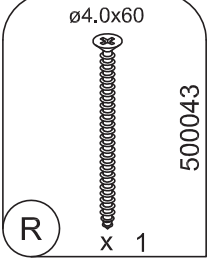
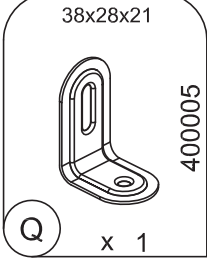
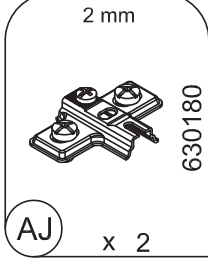
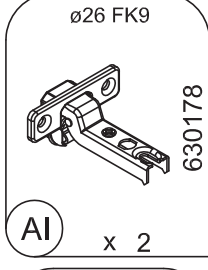
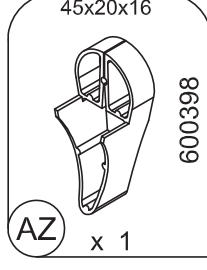
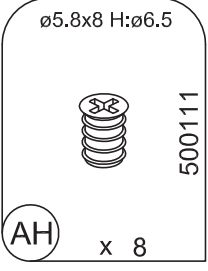
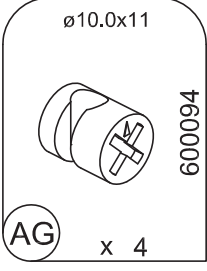
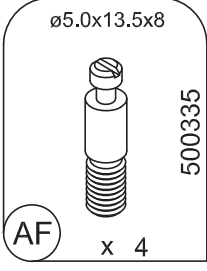
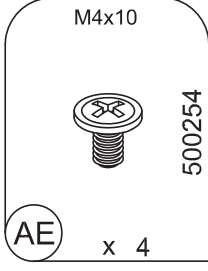
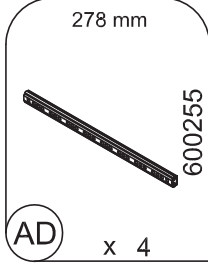
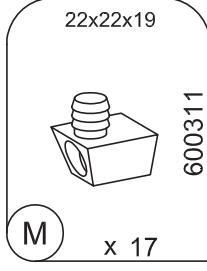
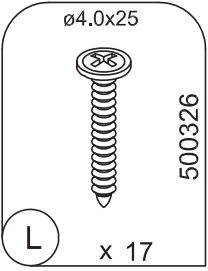
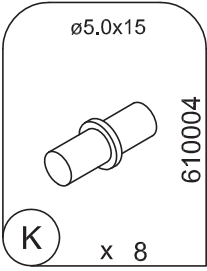
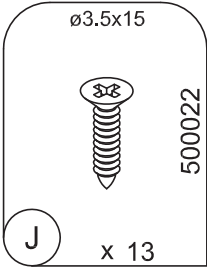
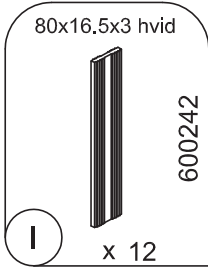
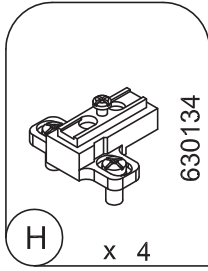
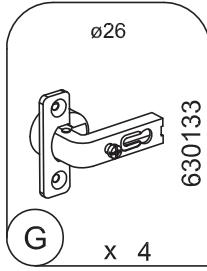
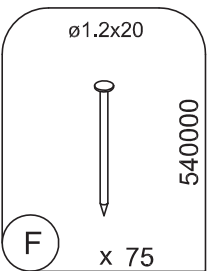
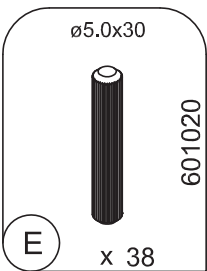
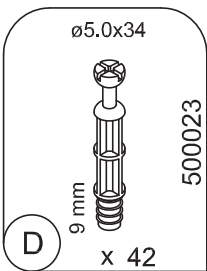
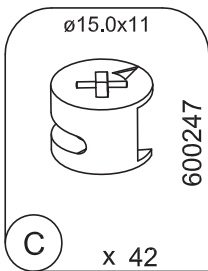
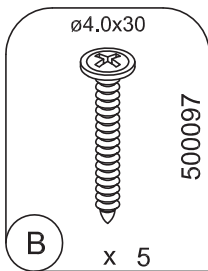
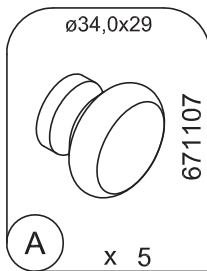

D Leim  
GB Glue  
FR Colle  
IT Colla  
NL Lijm  
PL Klej  
CZ Lepidlo  
SK Glej  
HU Enyv  
RO Adeziv  
TR Tutkal  
RU Клей

300001

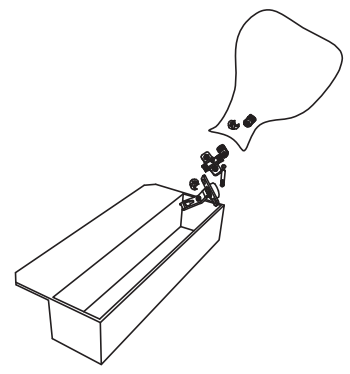
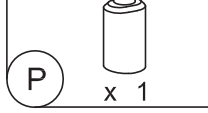

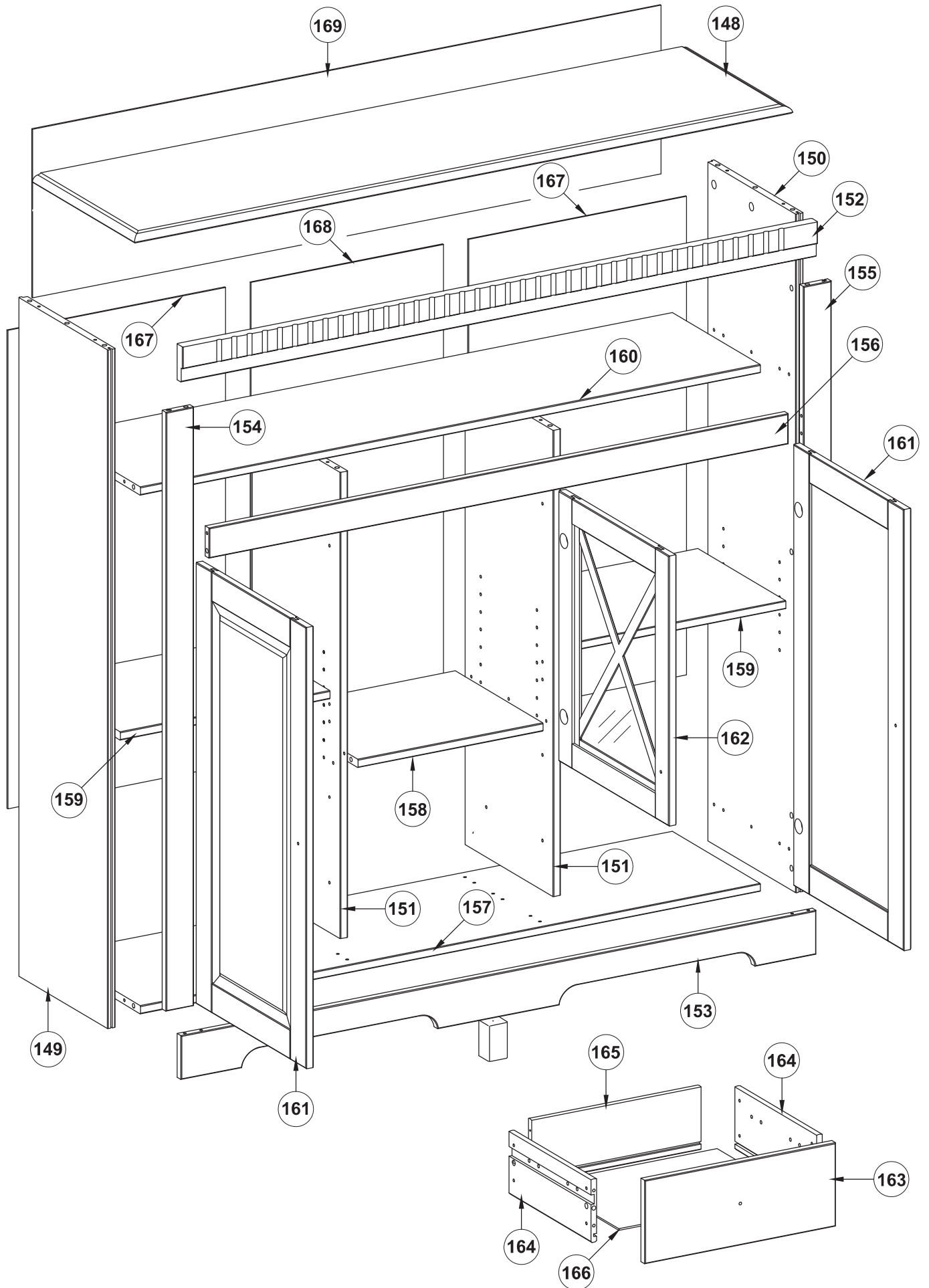

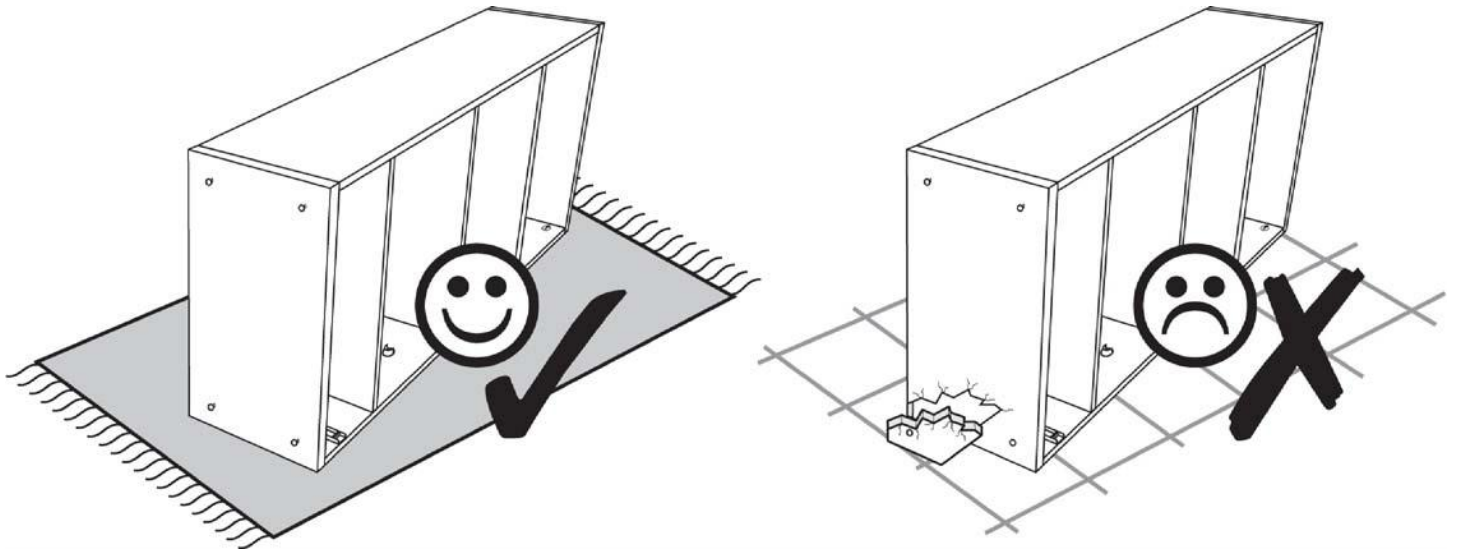

01

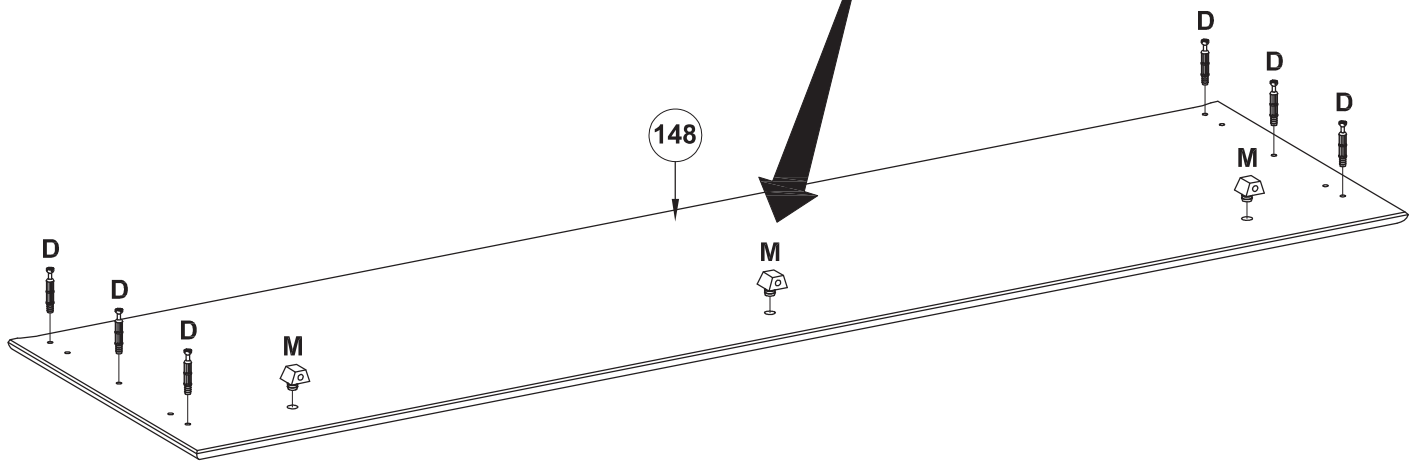
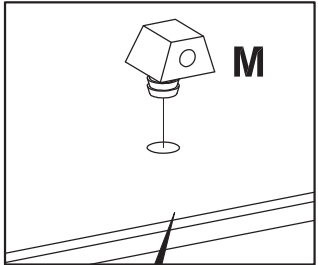
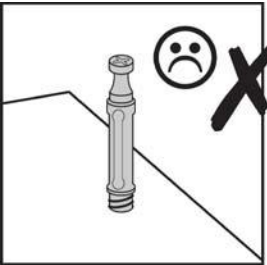
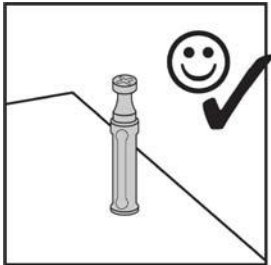
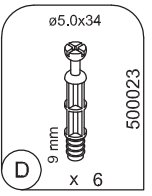
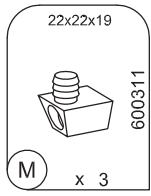
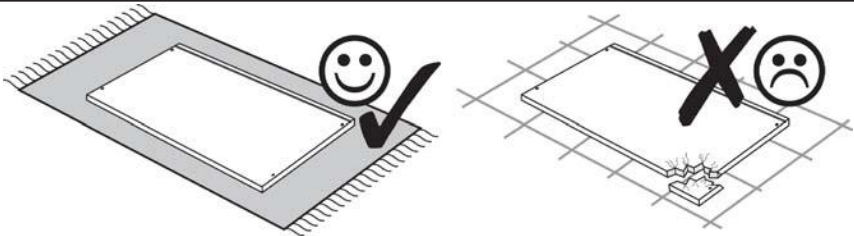

02

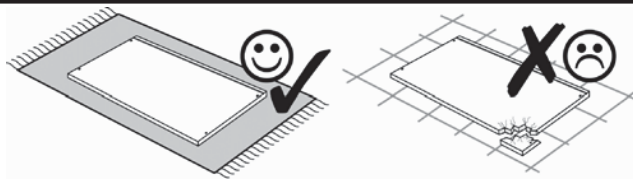

- D Leim
  - GB Glue
  - FR Colle
  - IT Colla
  - NL Lijm
  - PL Klej
  - CZ Lepidlo
  - SK Glej
  - HU Enyv
  - RO Adeziv
  - TR Tutkal
  - RU Клей
- 300001

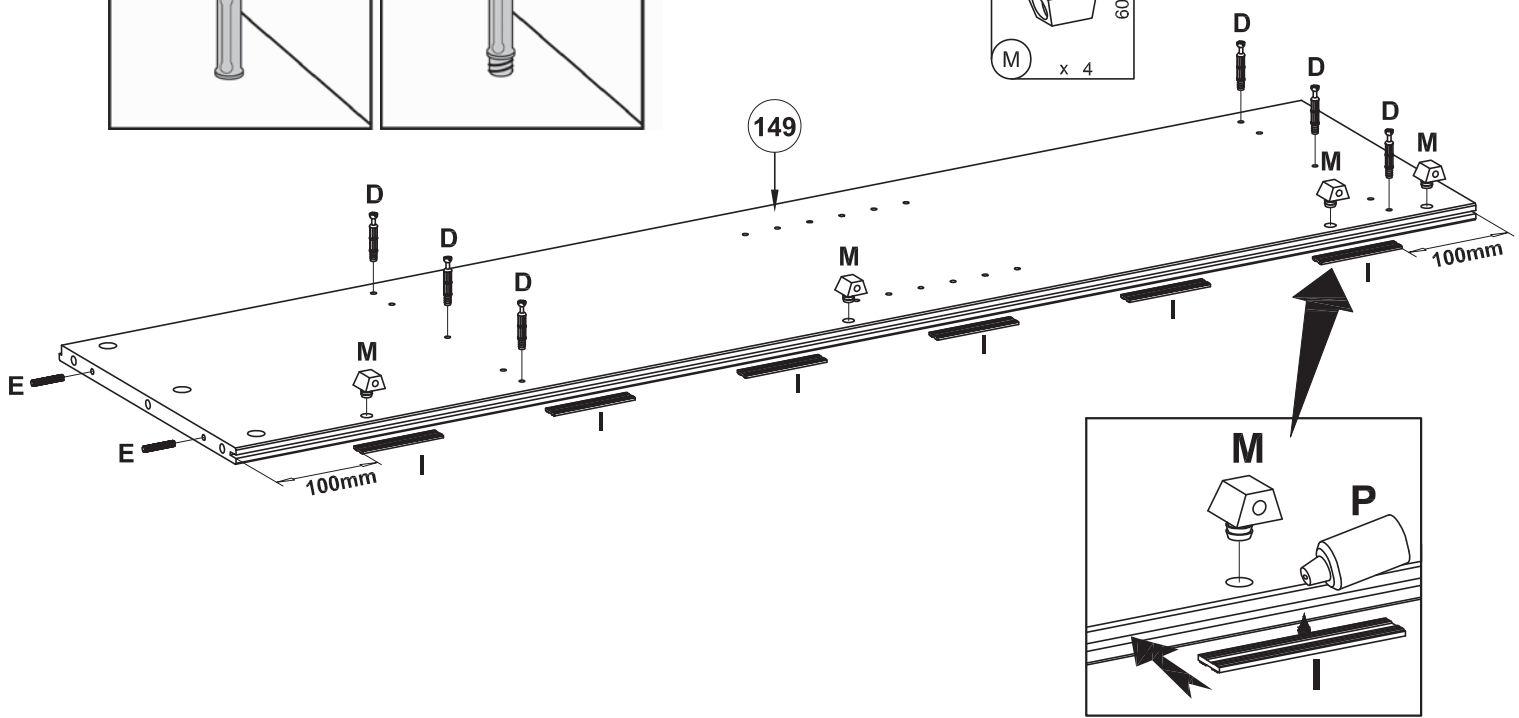
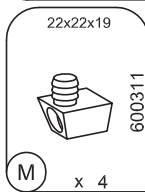
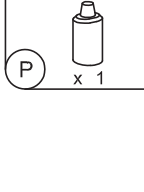
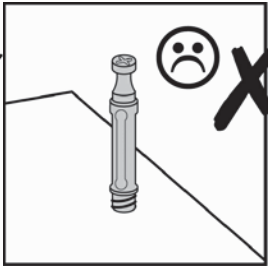
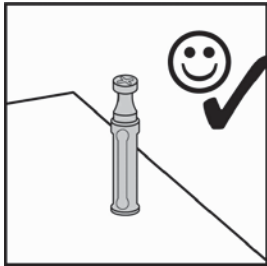
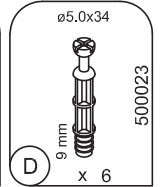
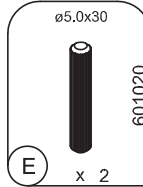
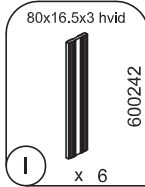

03

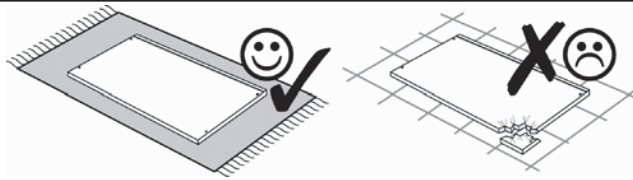

- D Leim
  - GB Glue
  - FR Colle
  - IT Colla
  - NL Lijm
  - PL Klej
  - CZ Lepidlo
  - SK Glej
  - HU Enyv
  - RO Adeziv
  - TR Tutkal
  - RU Клей
- 300001

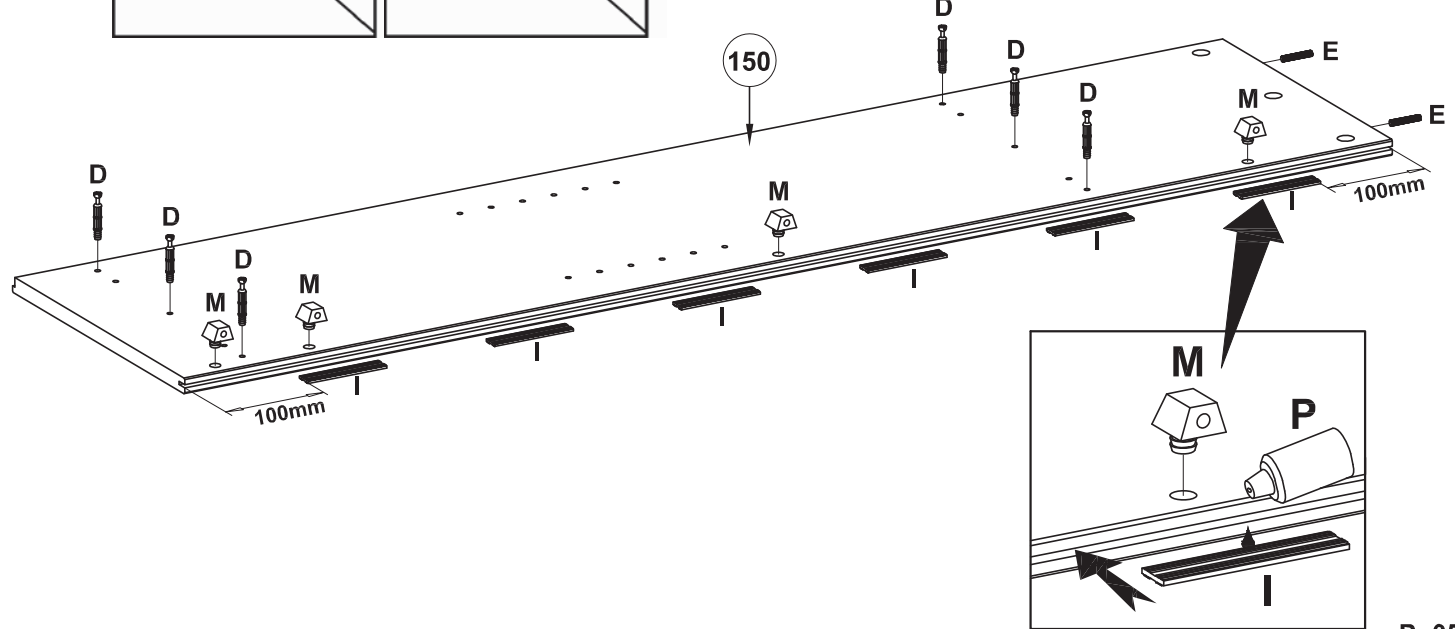
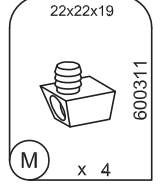
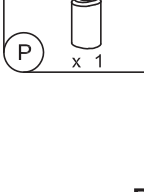
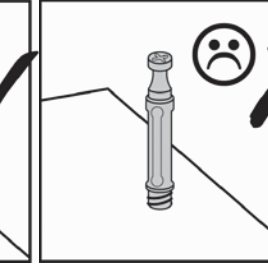
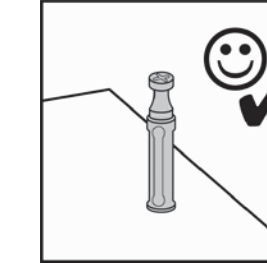
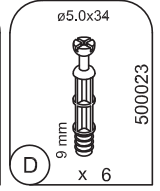
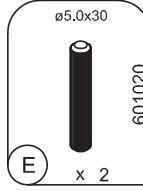
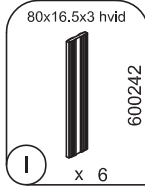

04

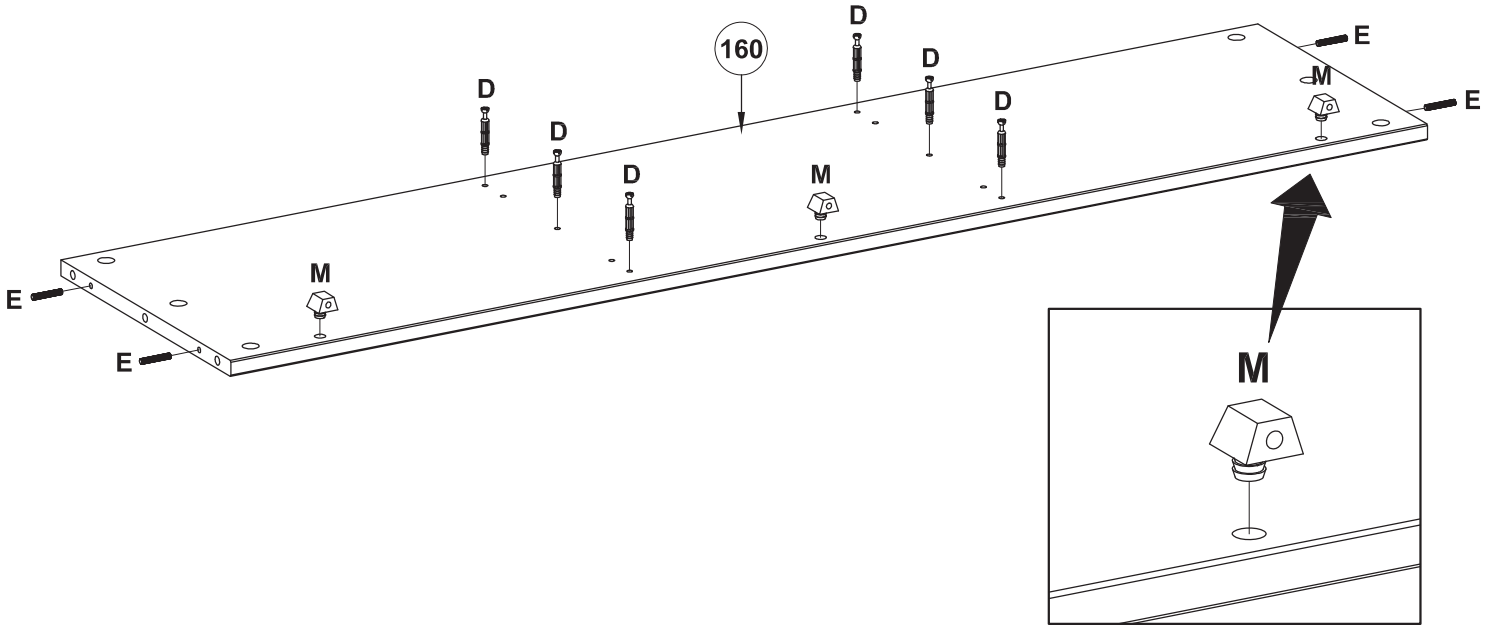
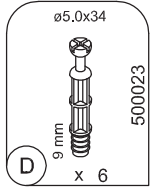
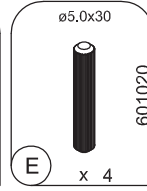
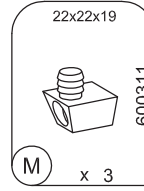
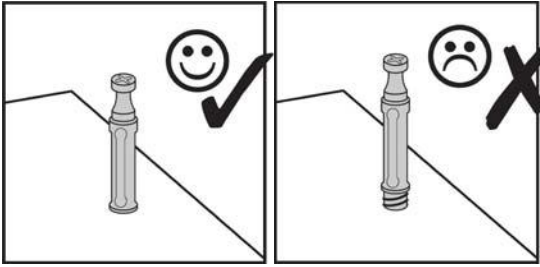

05

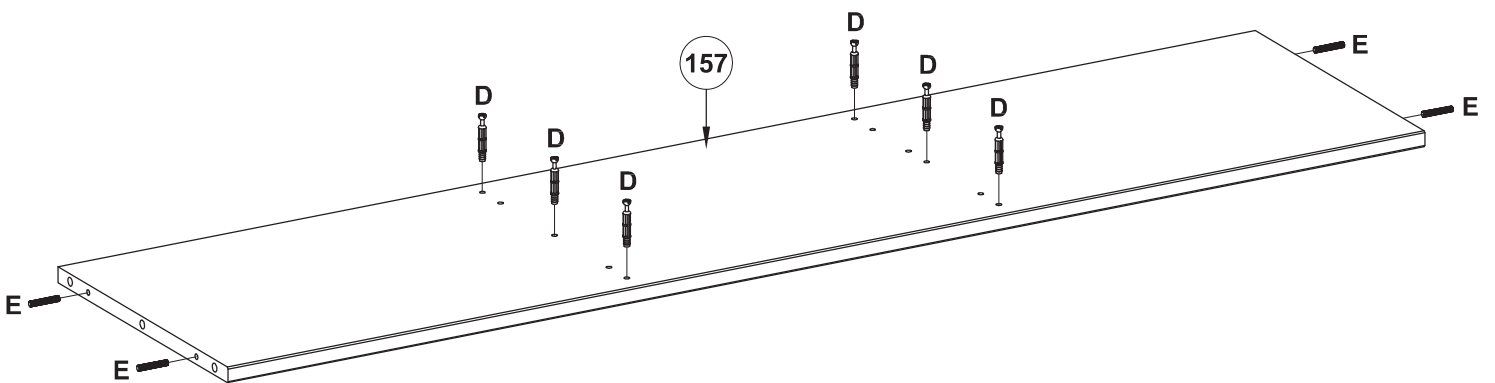
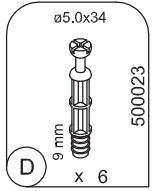
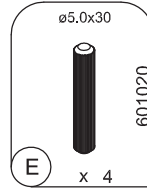
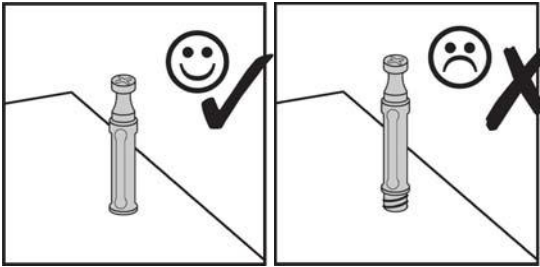



06

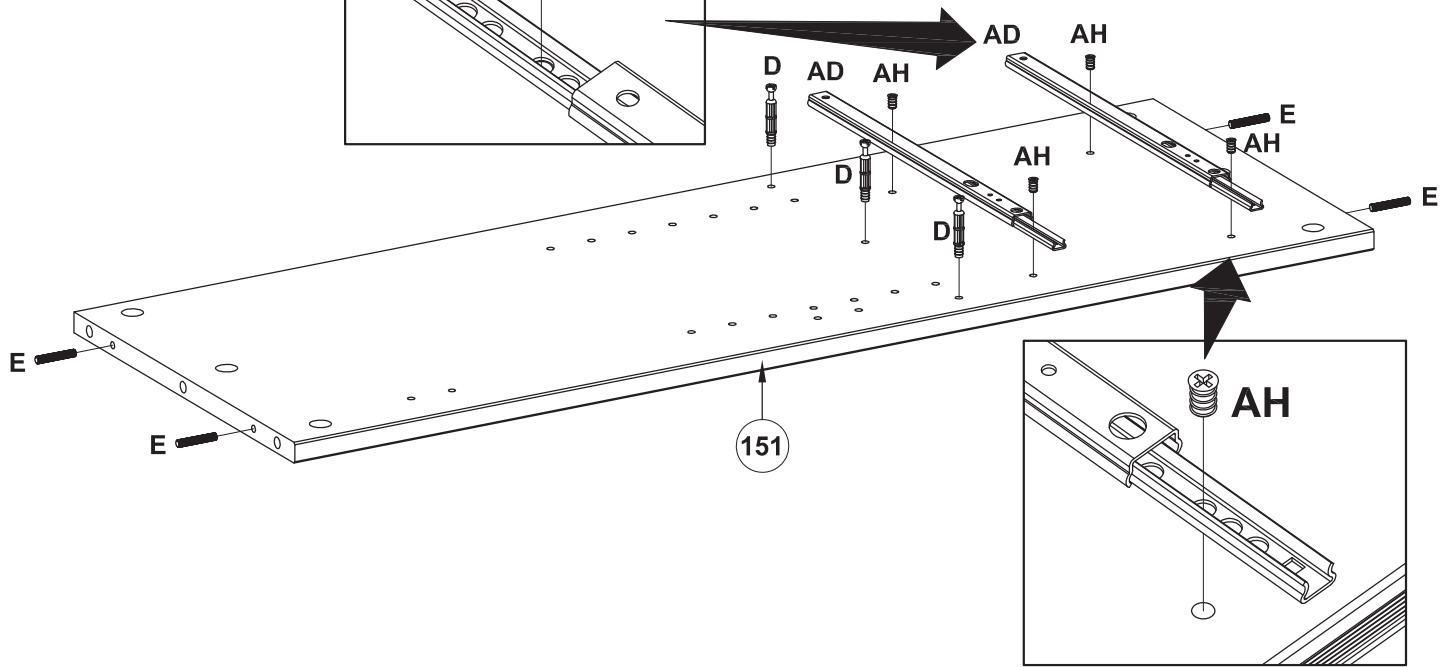
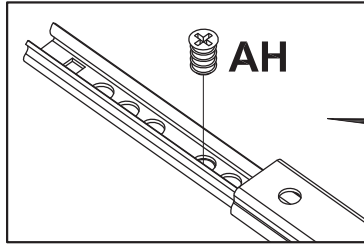
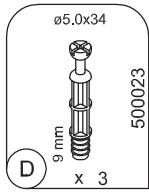
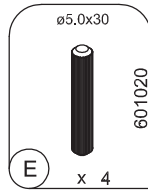
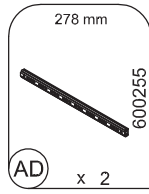
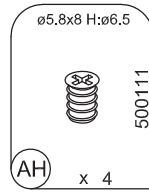
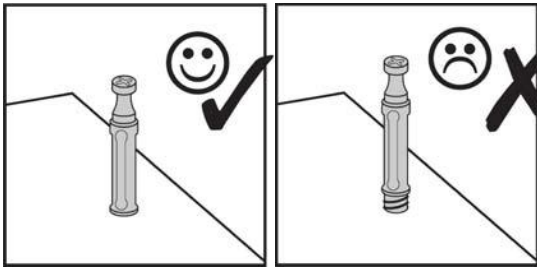

07

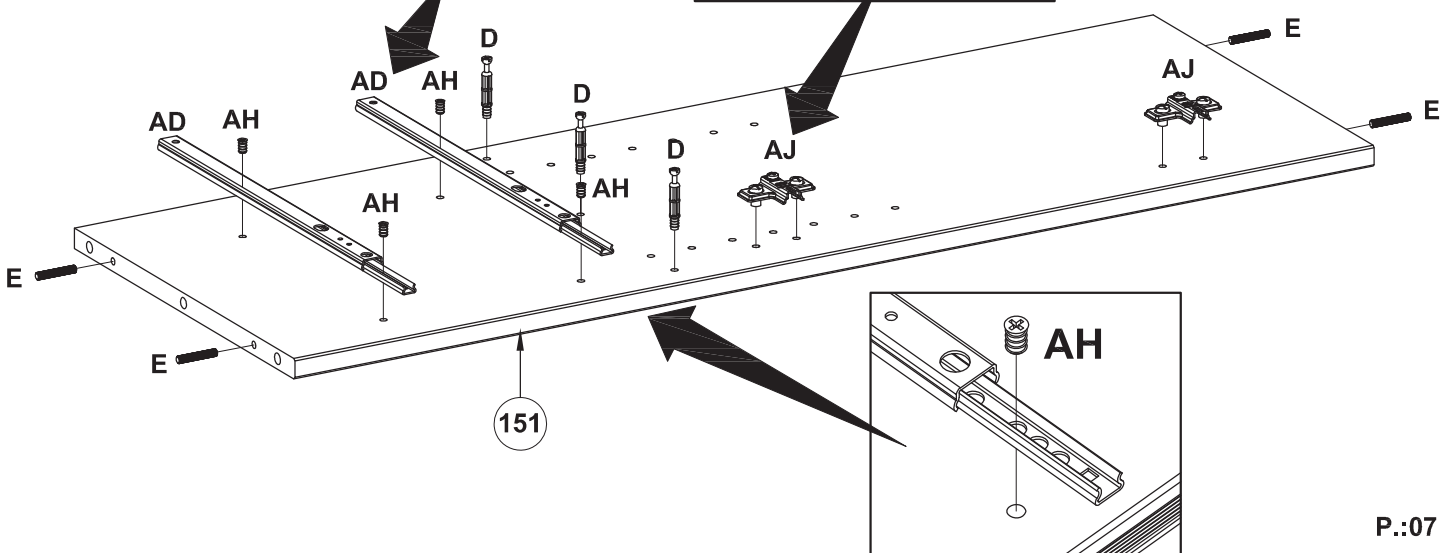
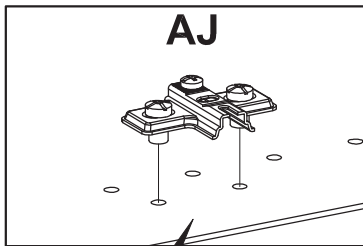
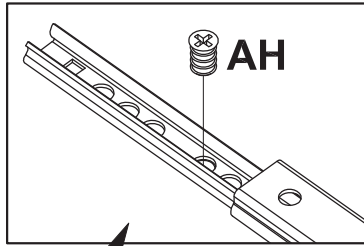
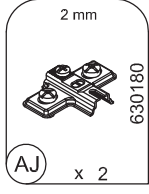
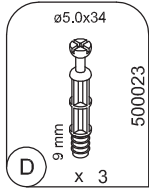
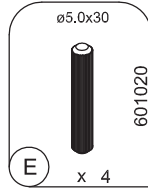
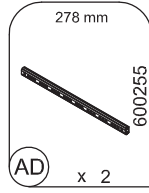
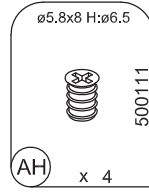
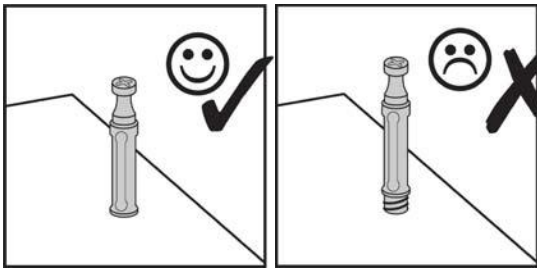

08

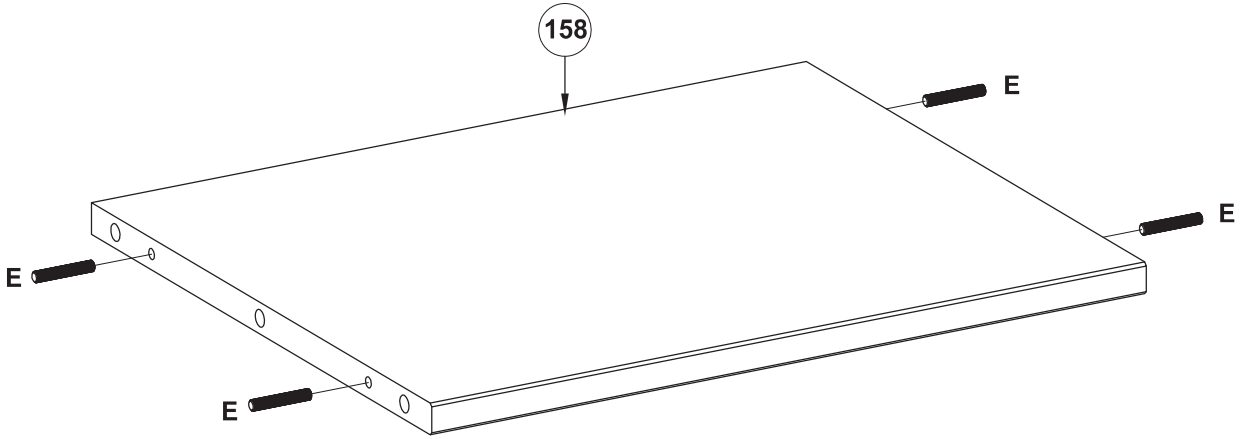
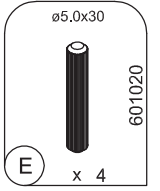

09

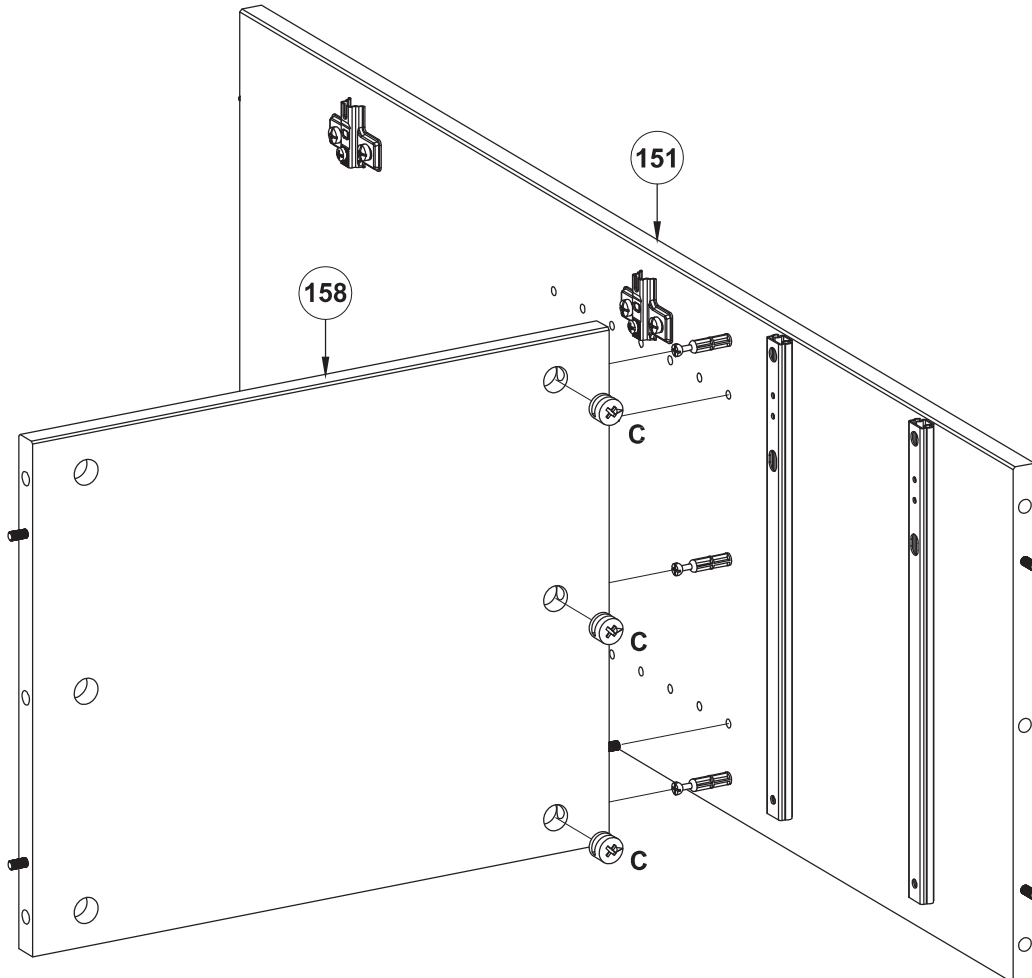
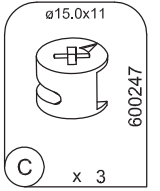



10

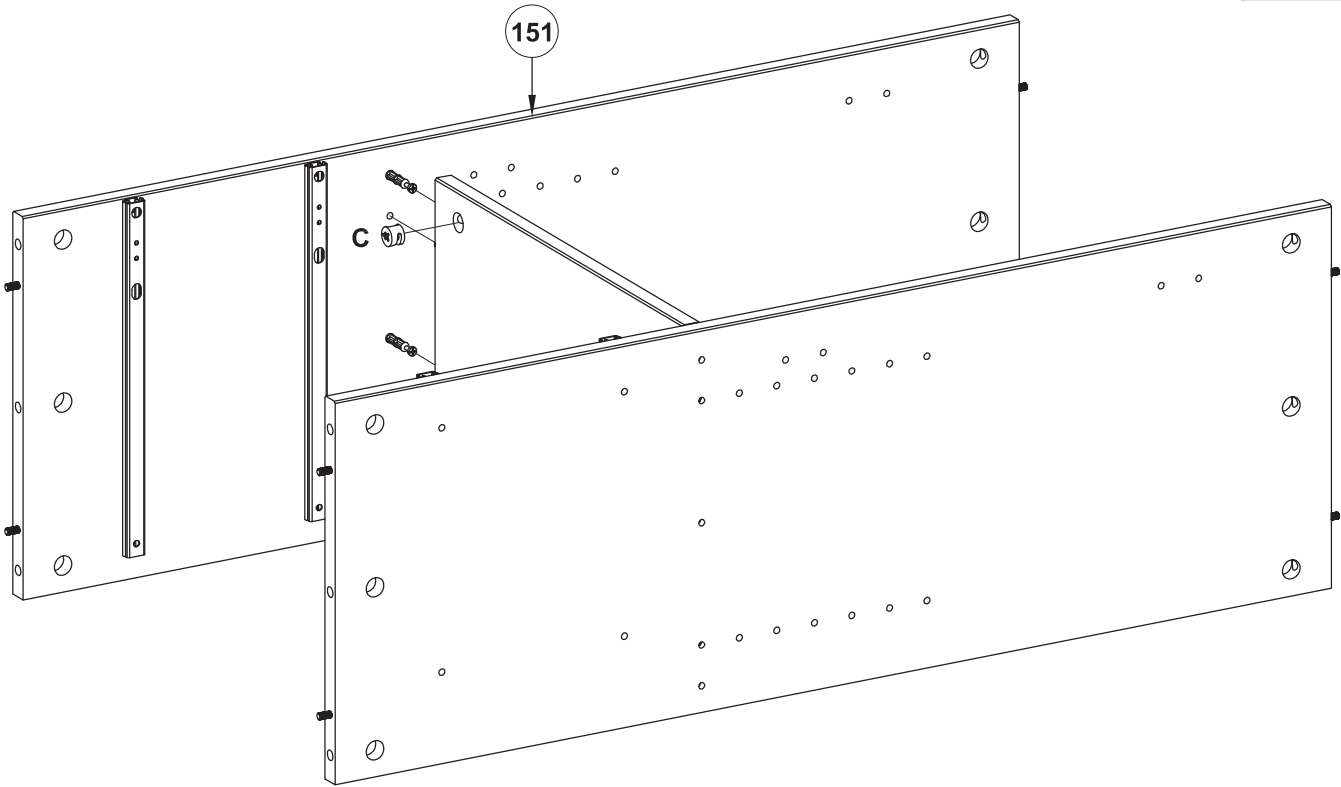
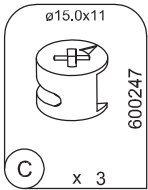

11

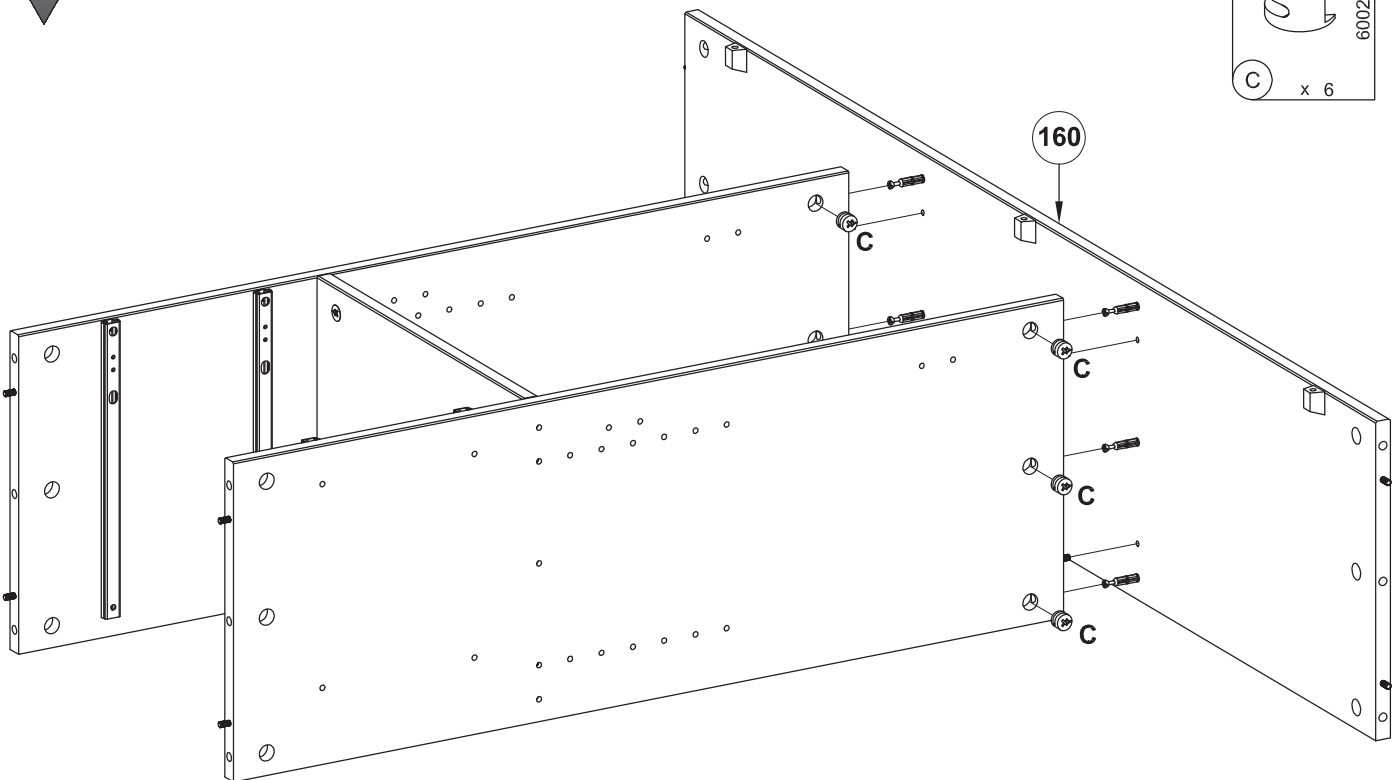
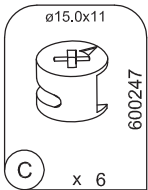

12

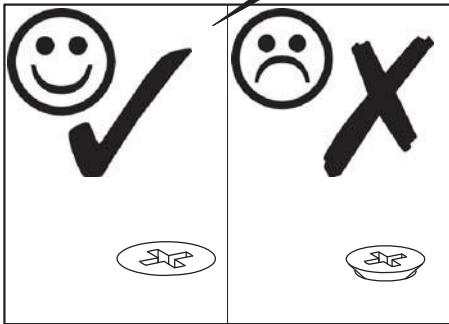
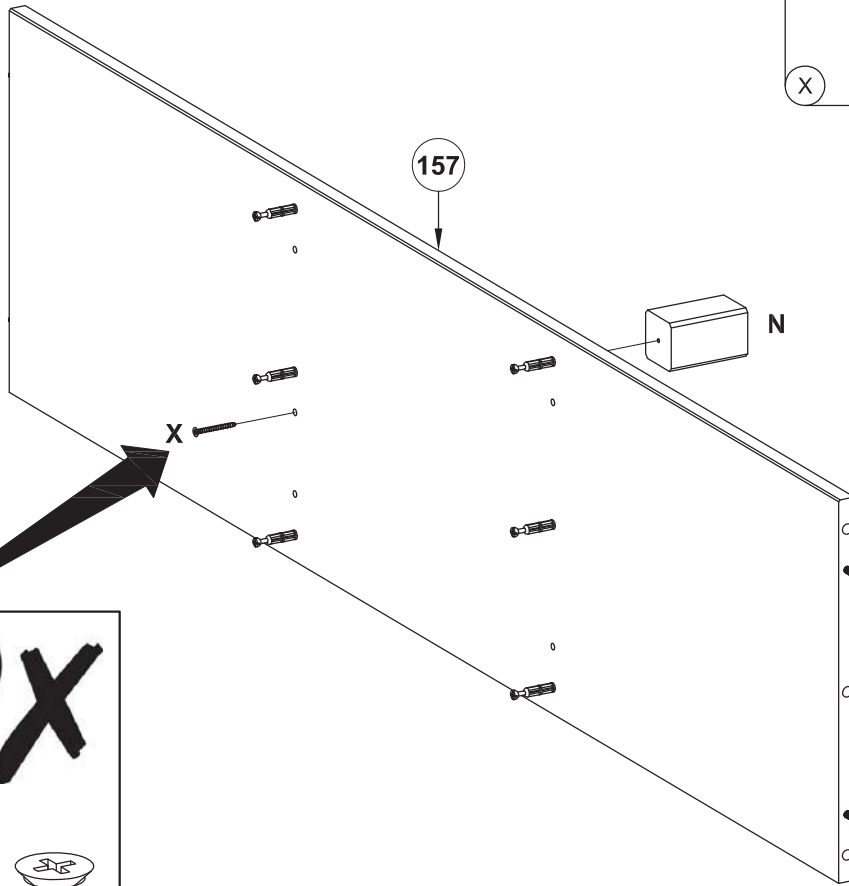
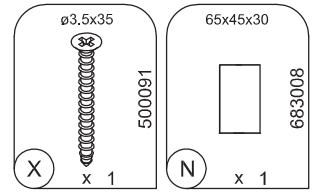

13

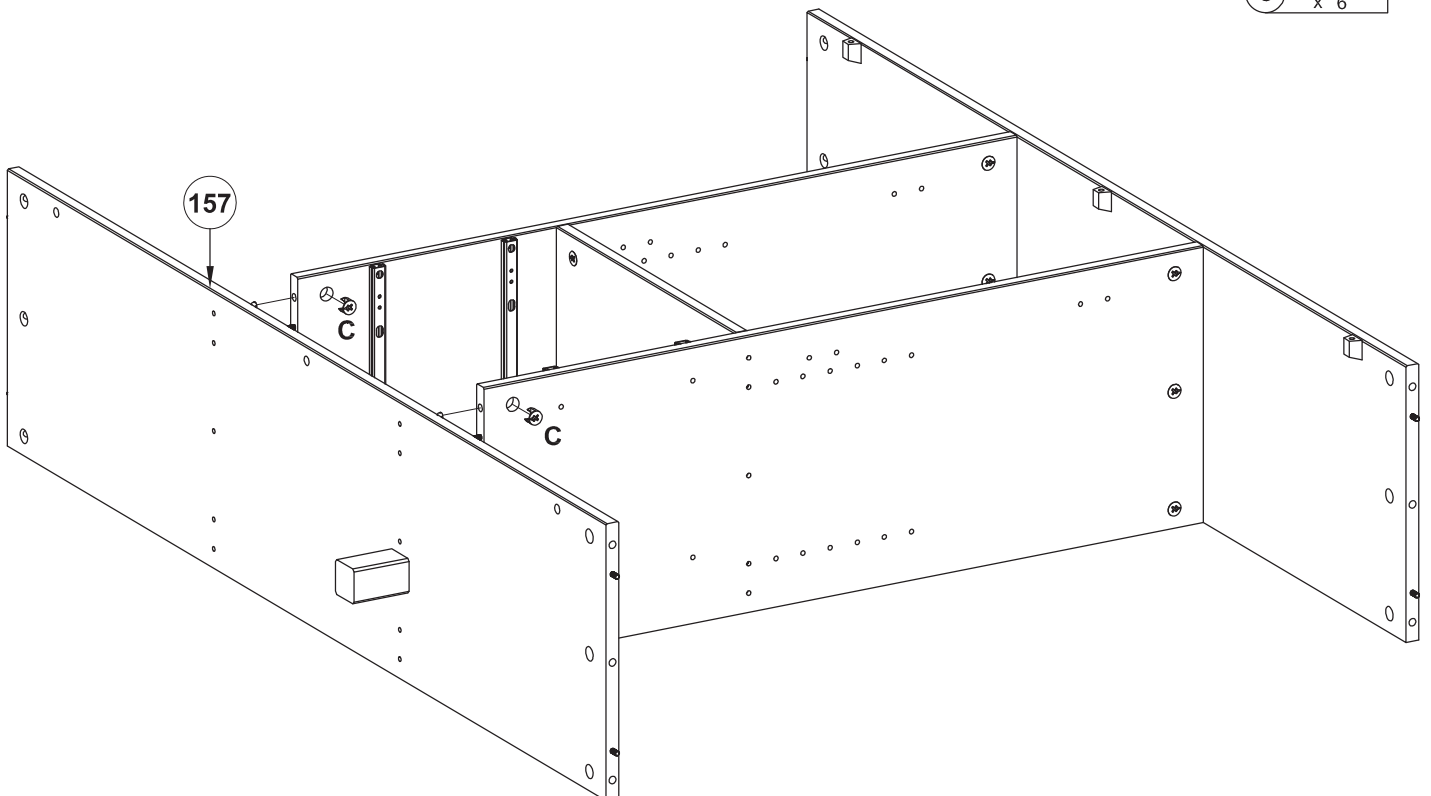
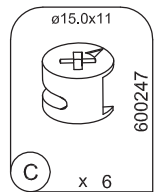

14

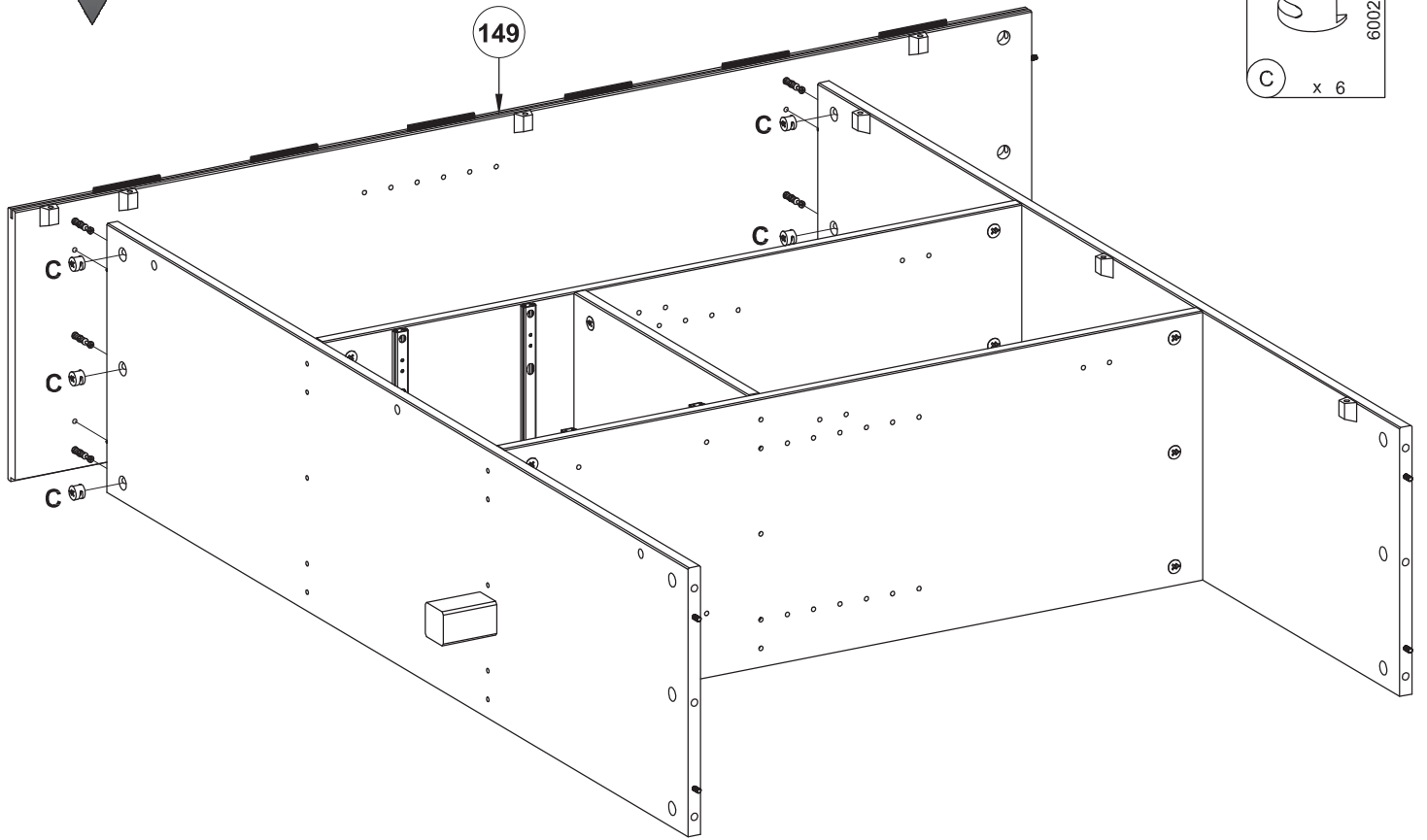

15

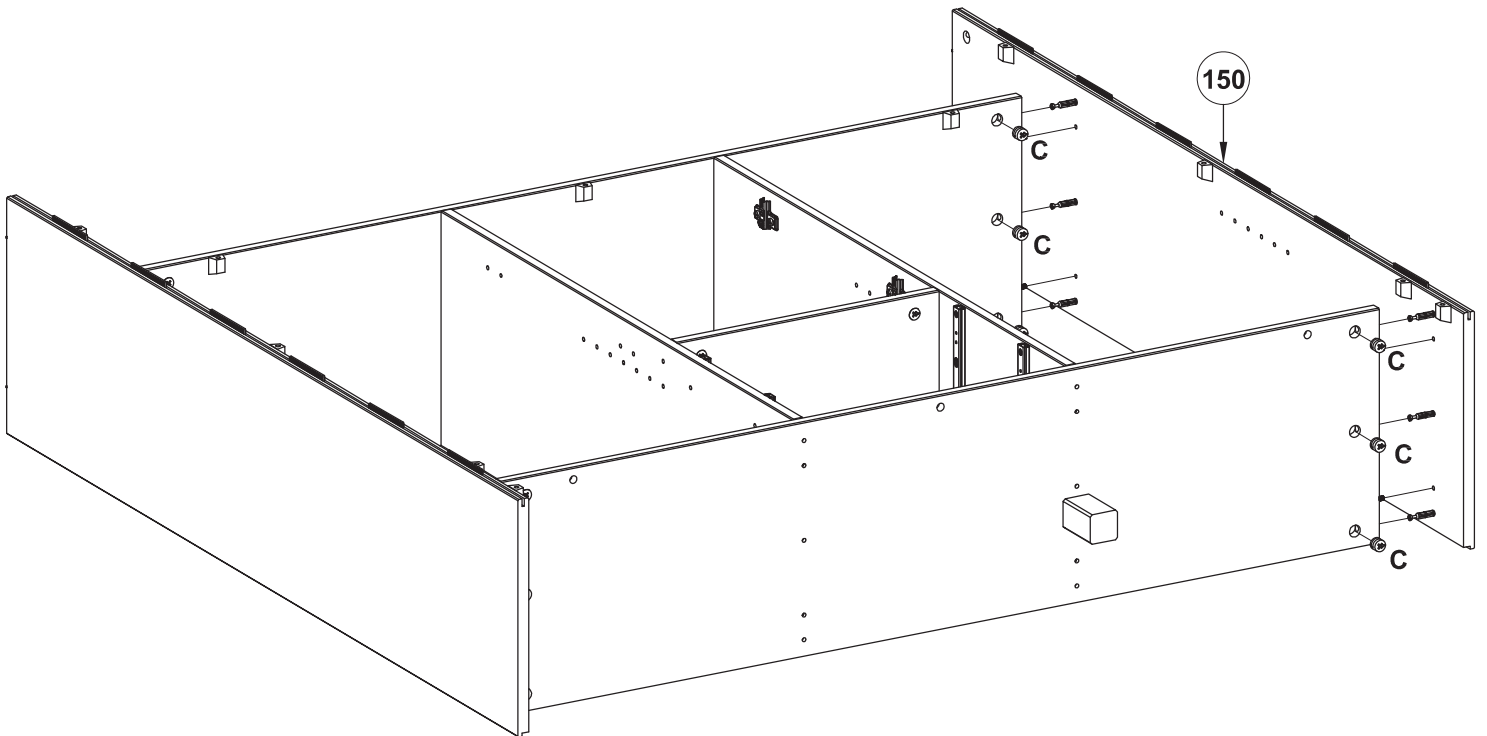

16

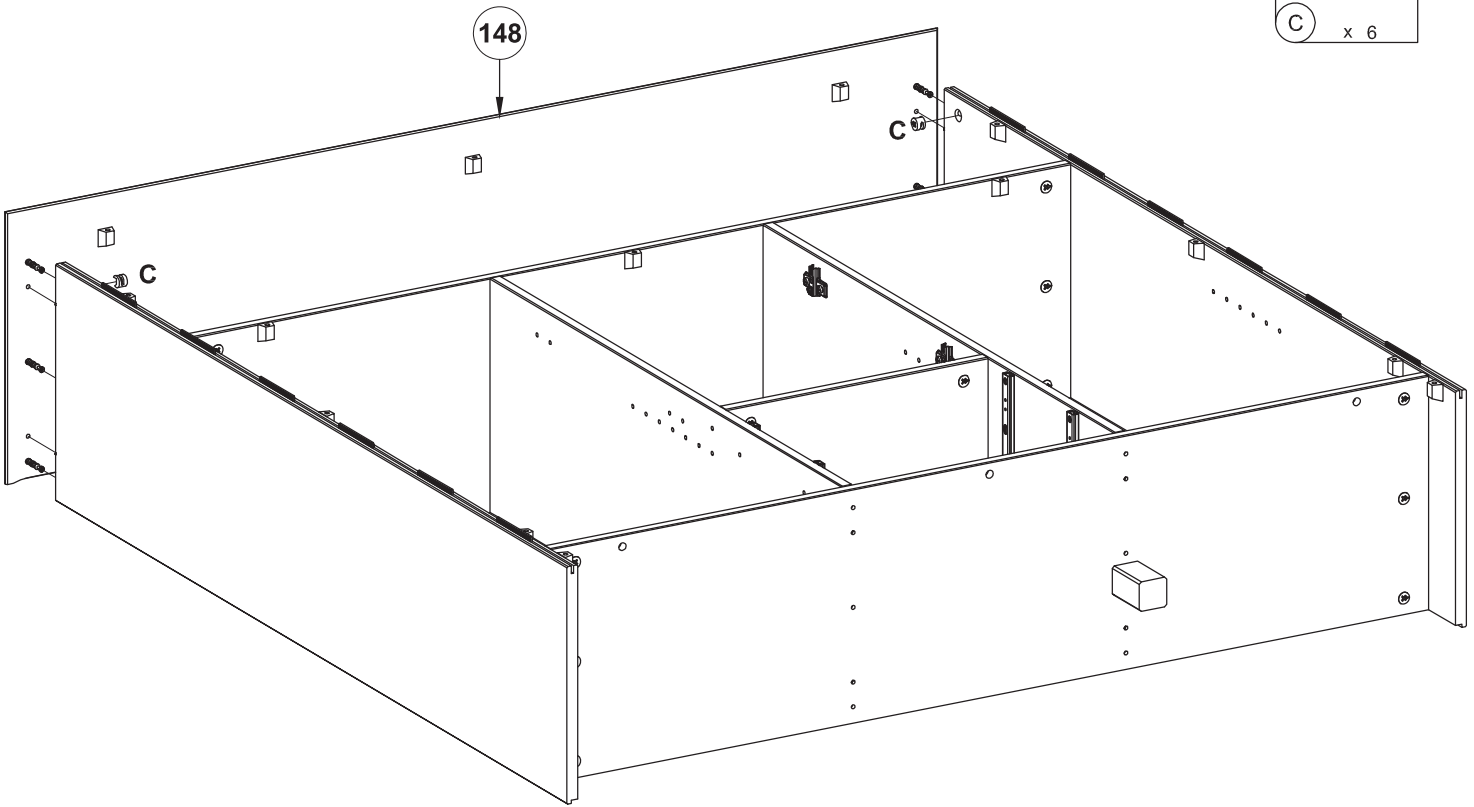
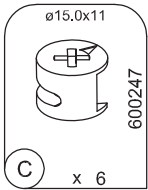

17

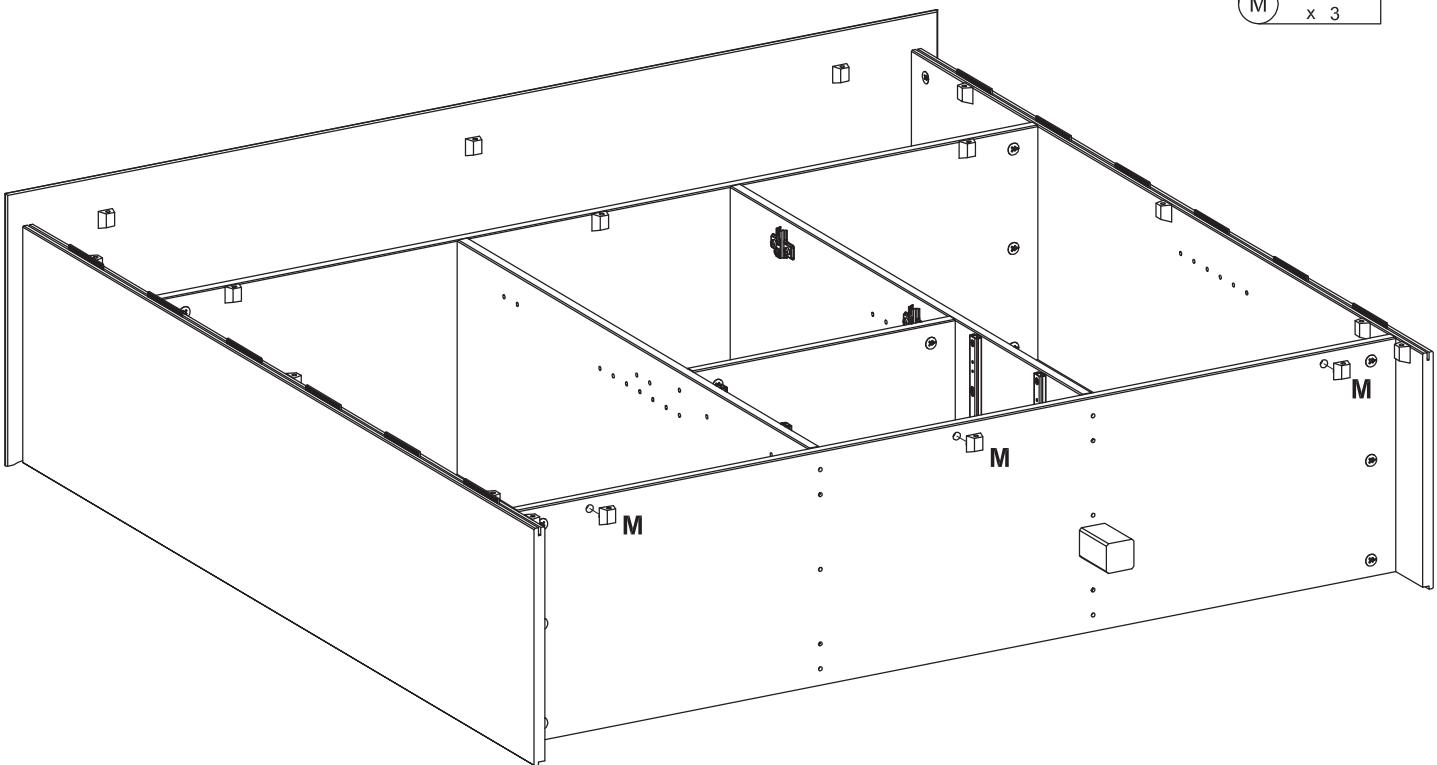
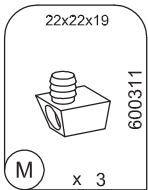

18

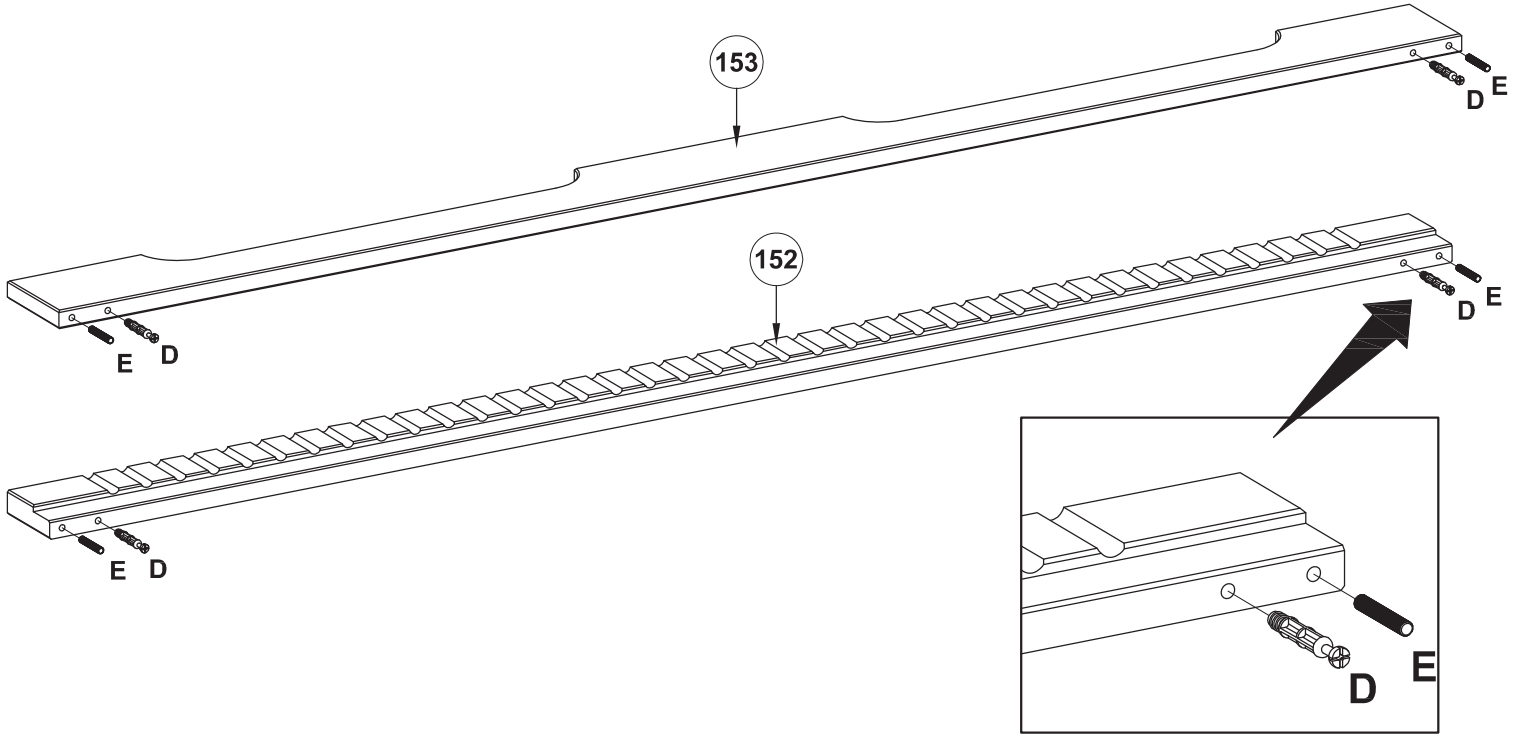
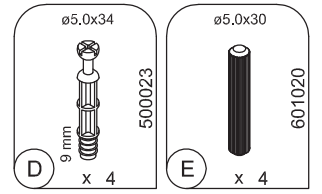
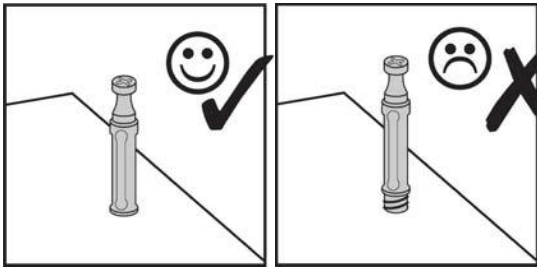

19

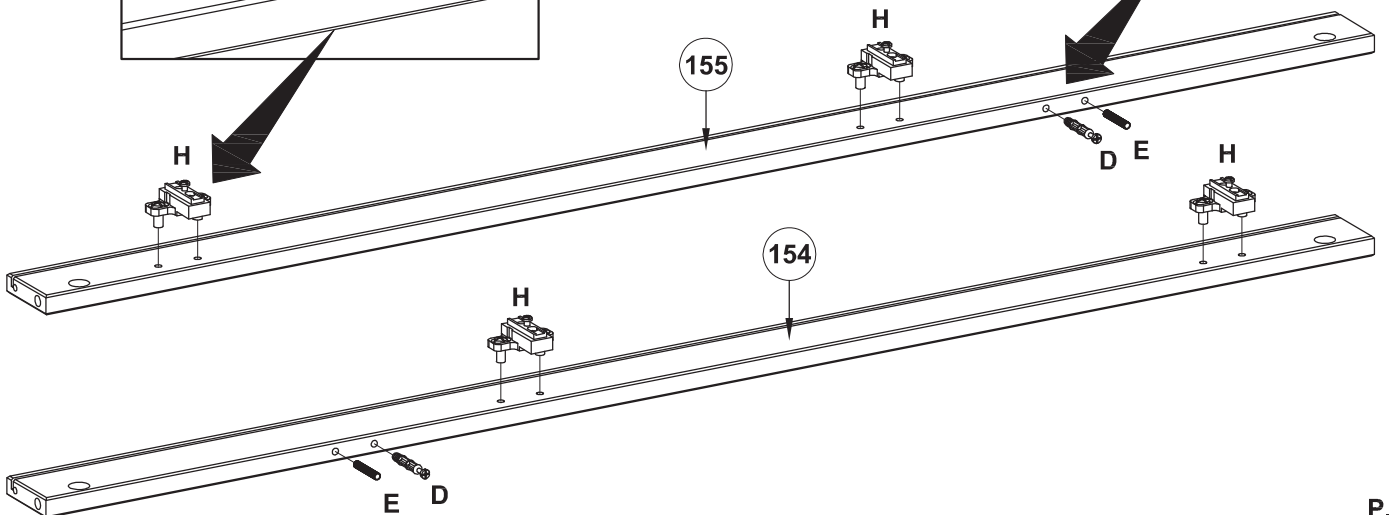
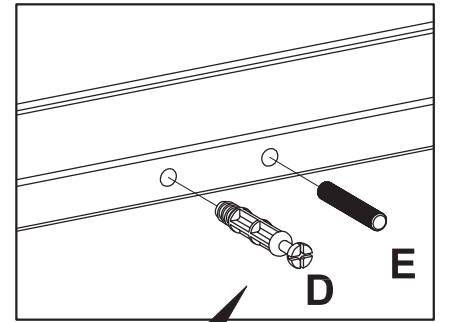
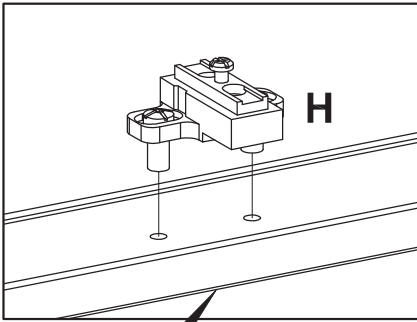
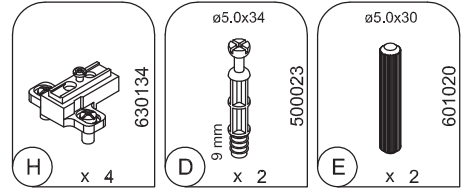
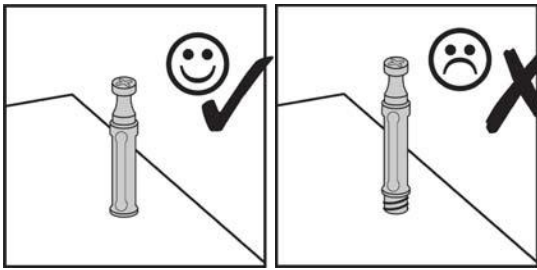

20

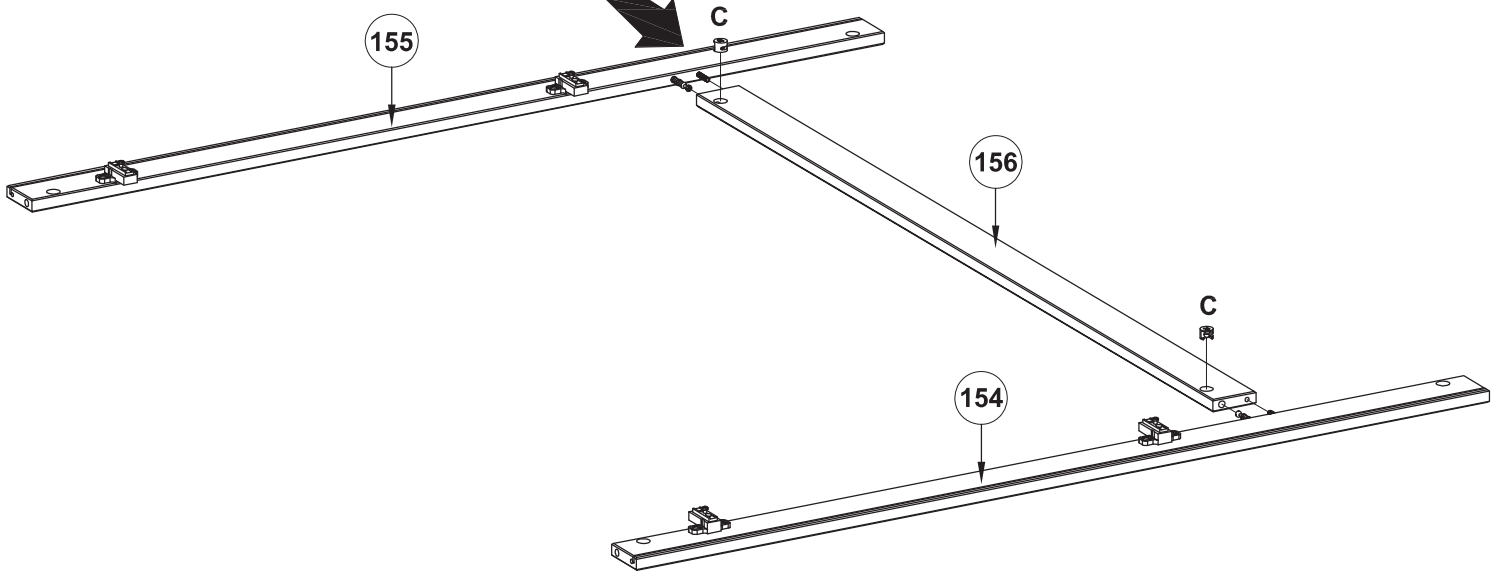
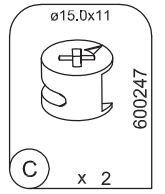
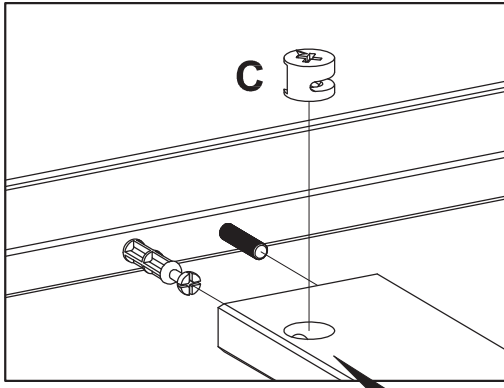

21

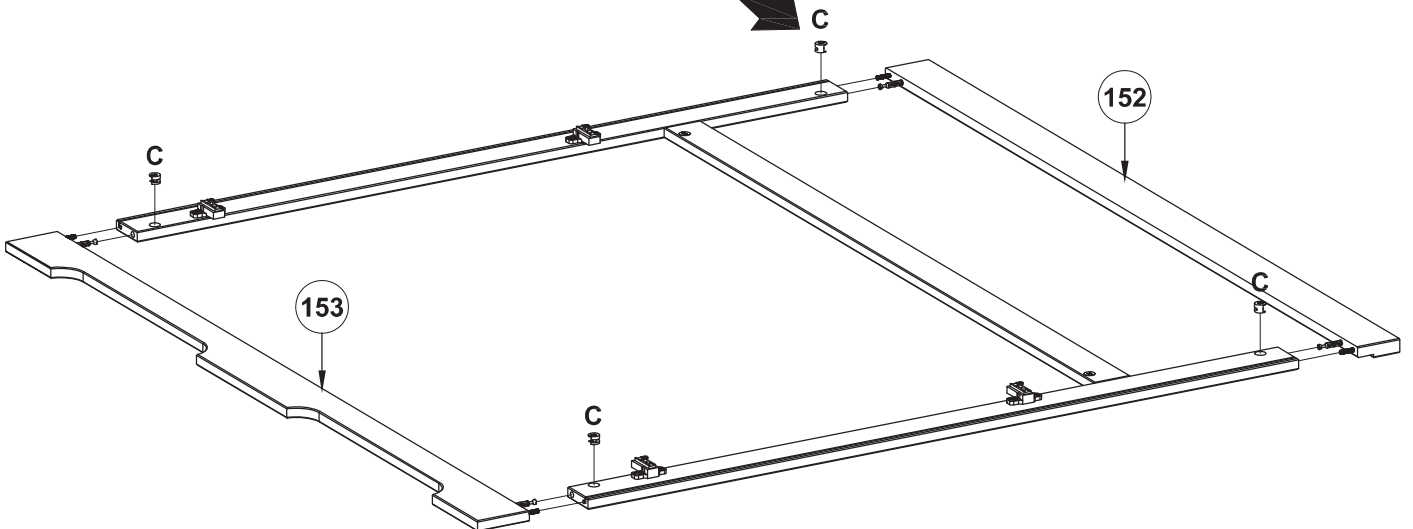
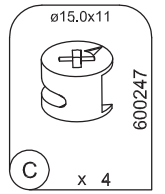
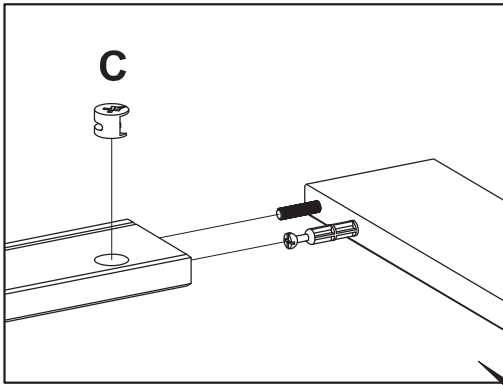

22

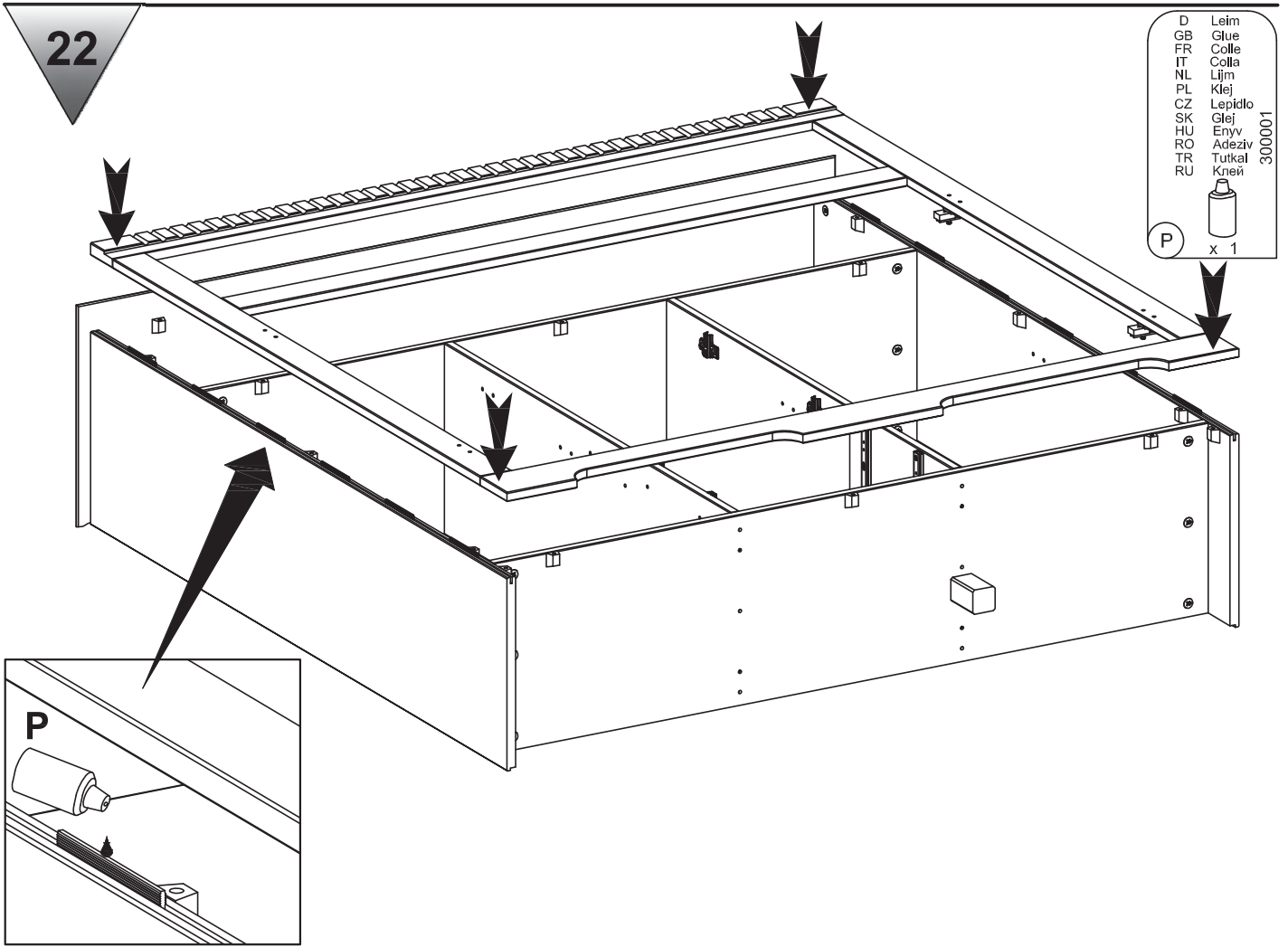

23

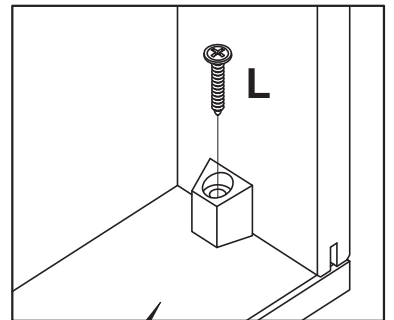
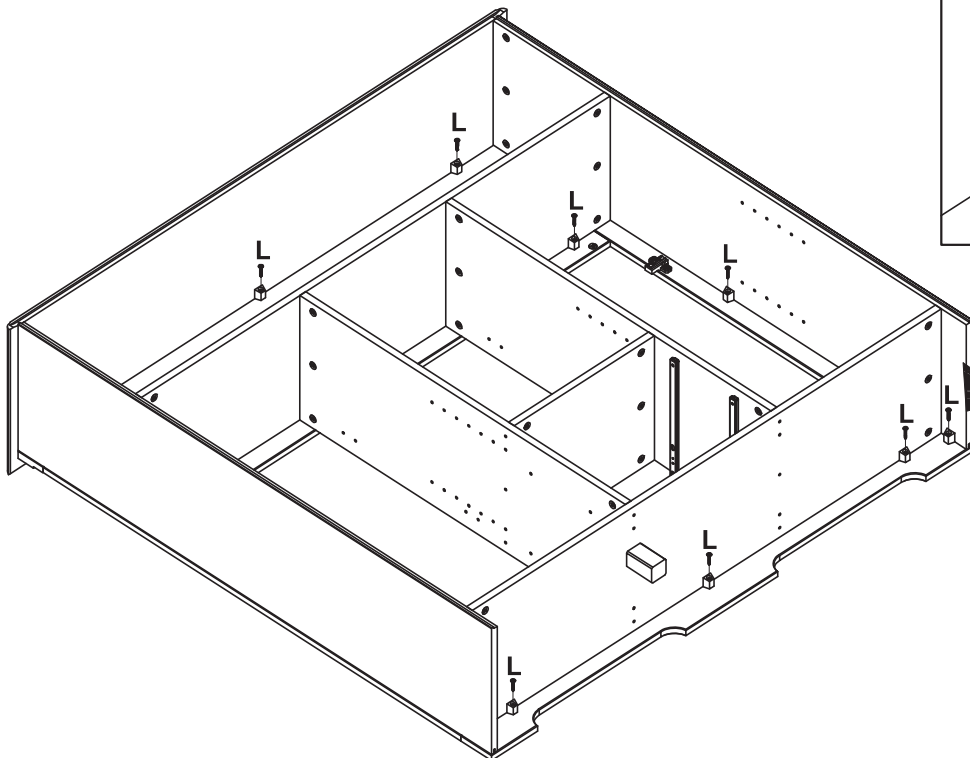
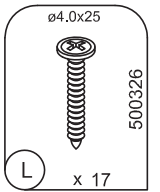
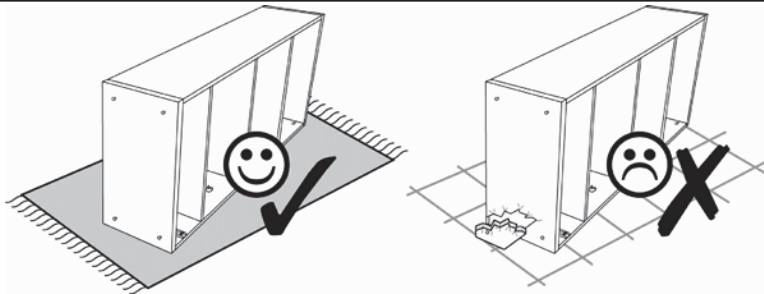



24

ø5.0x15



610004

(K)

x 8

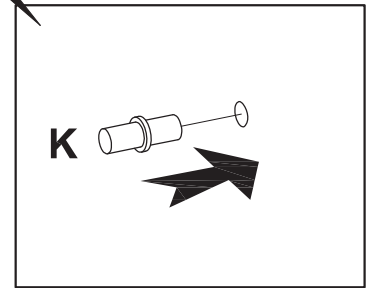
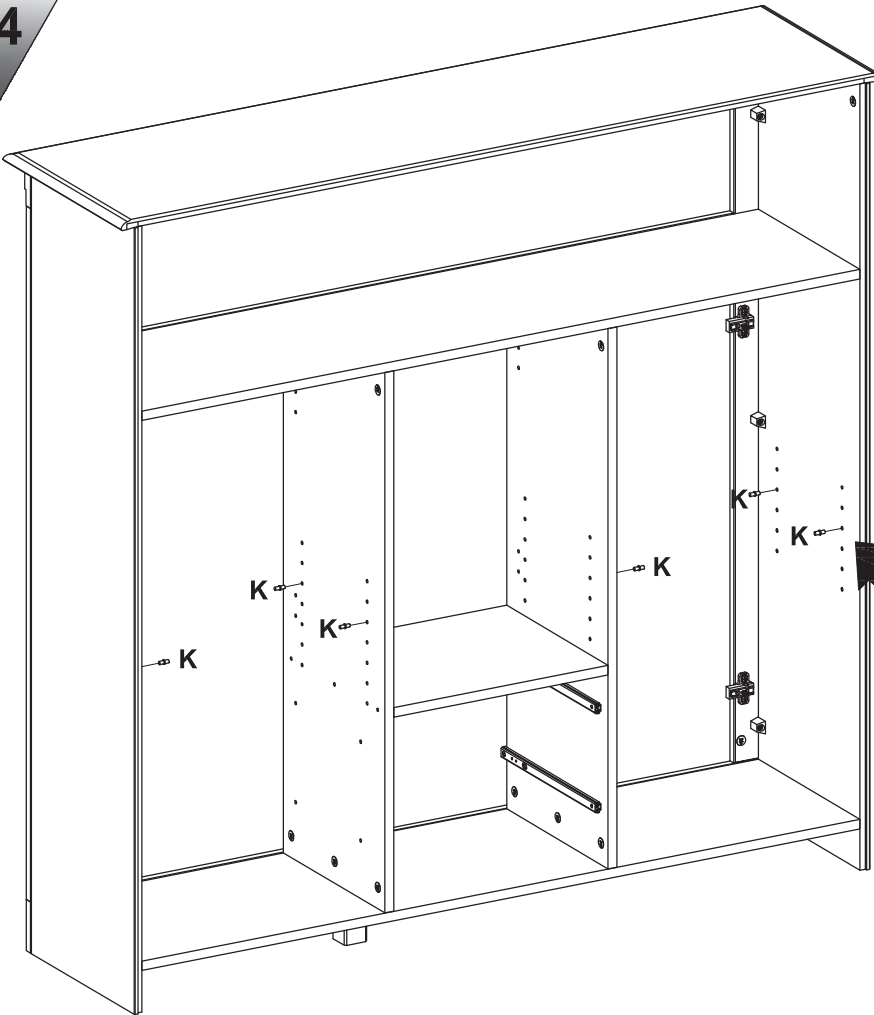

25

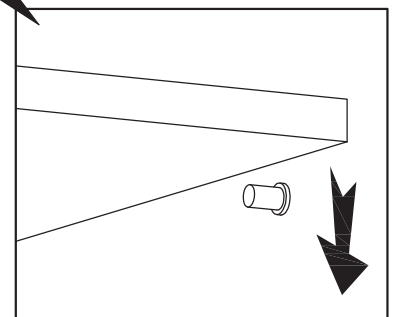
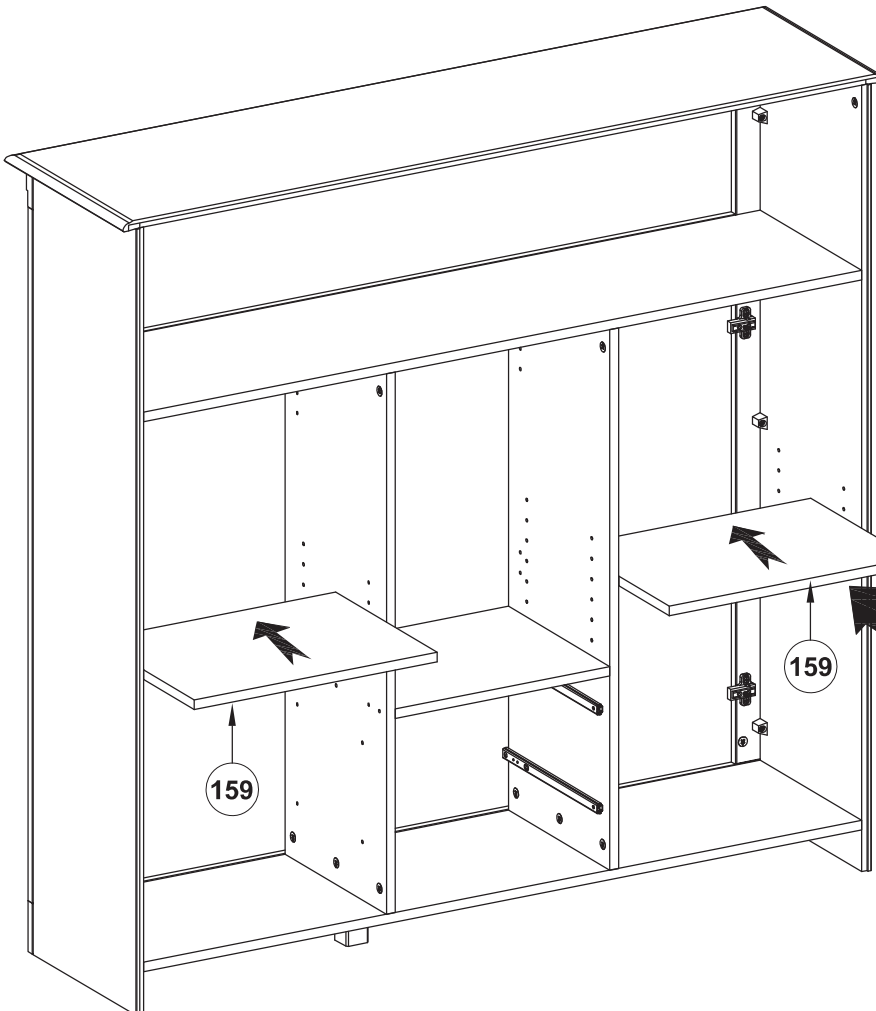

26

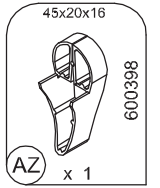
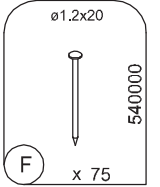
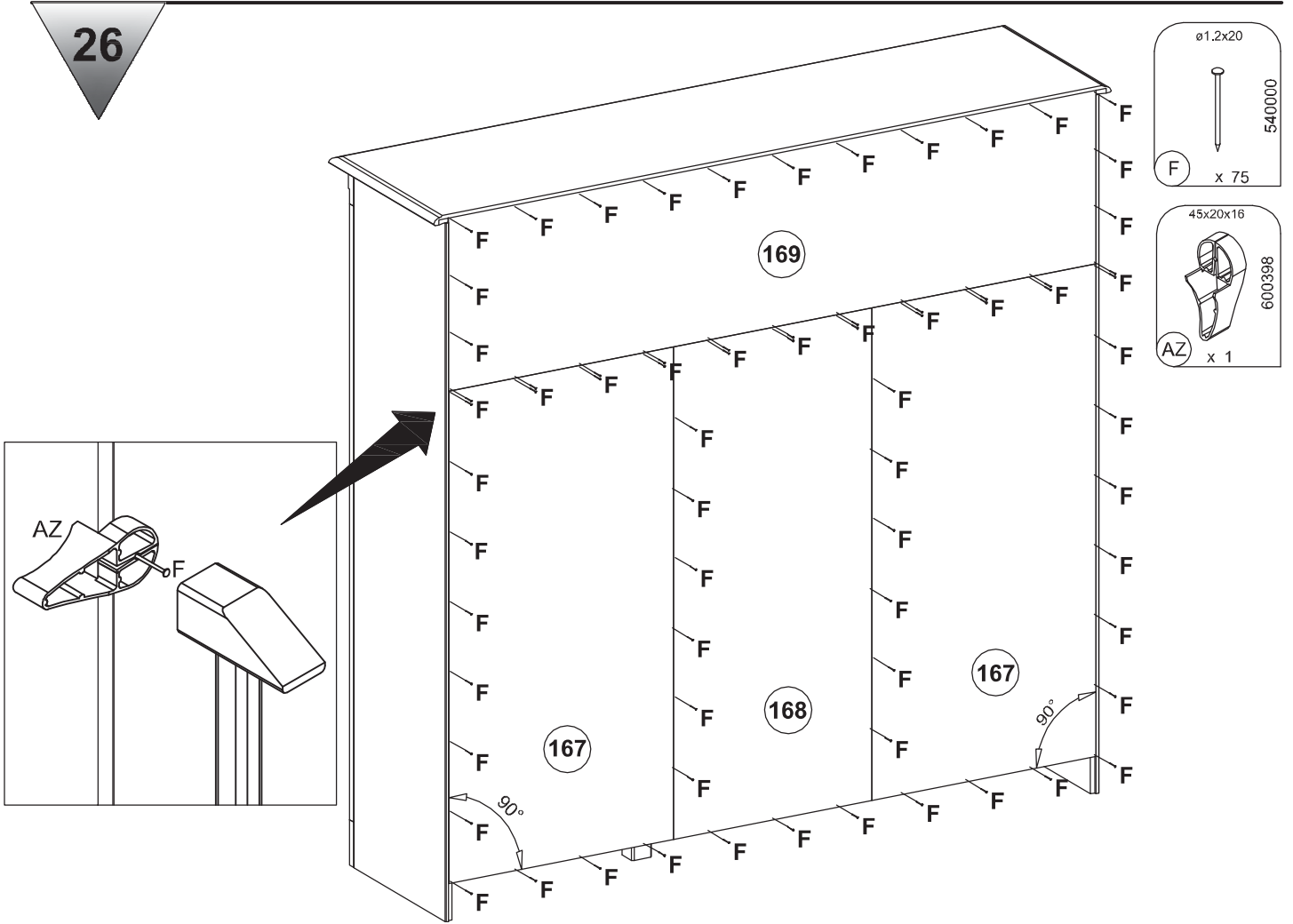

27

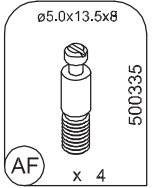
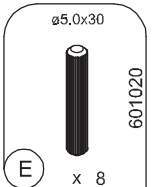
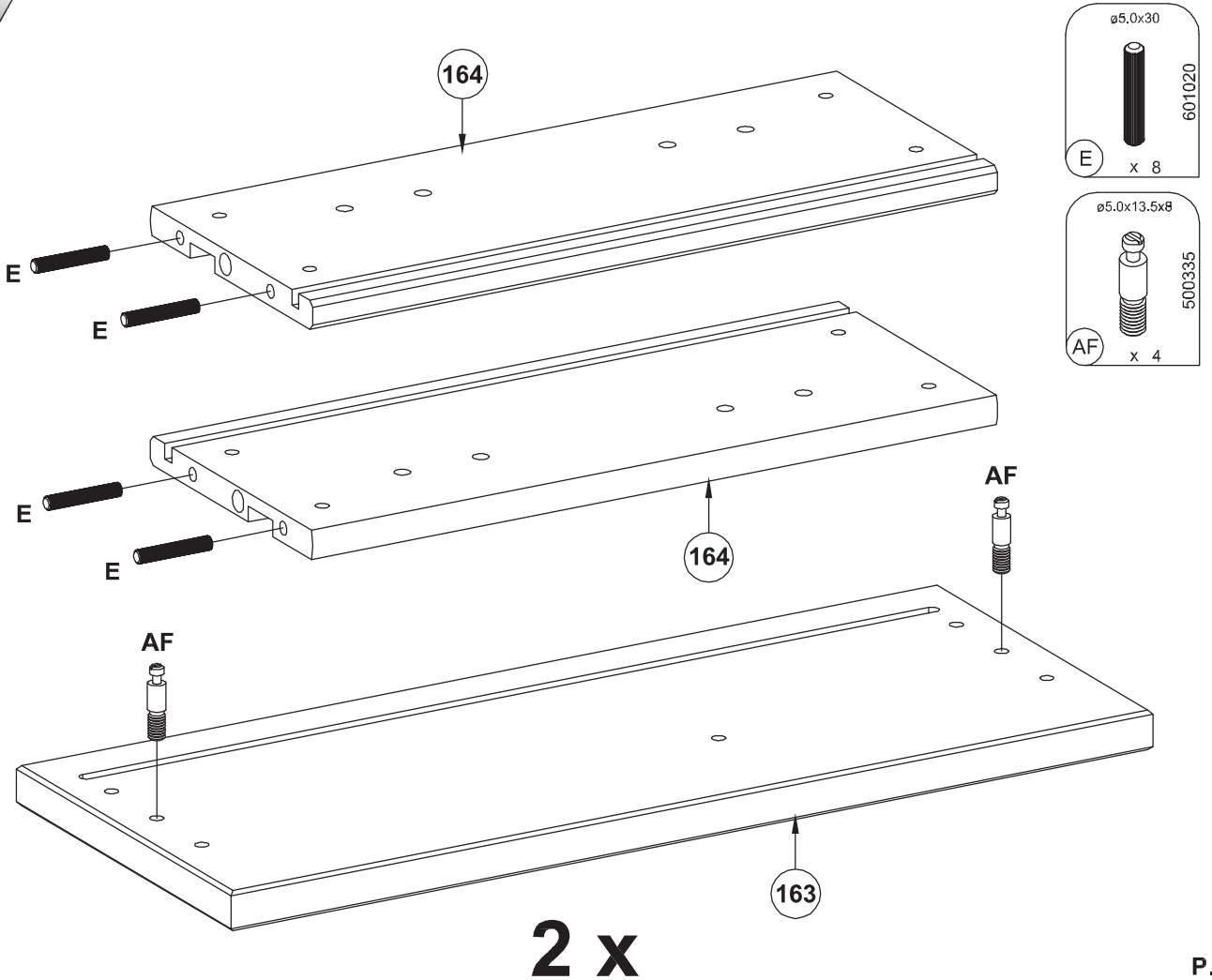

2 x

28

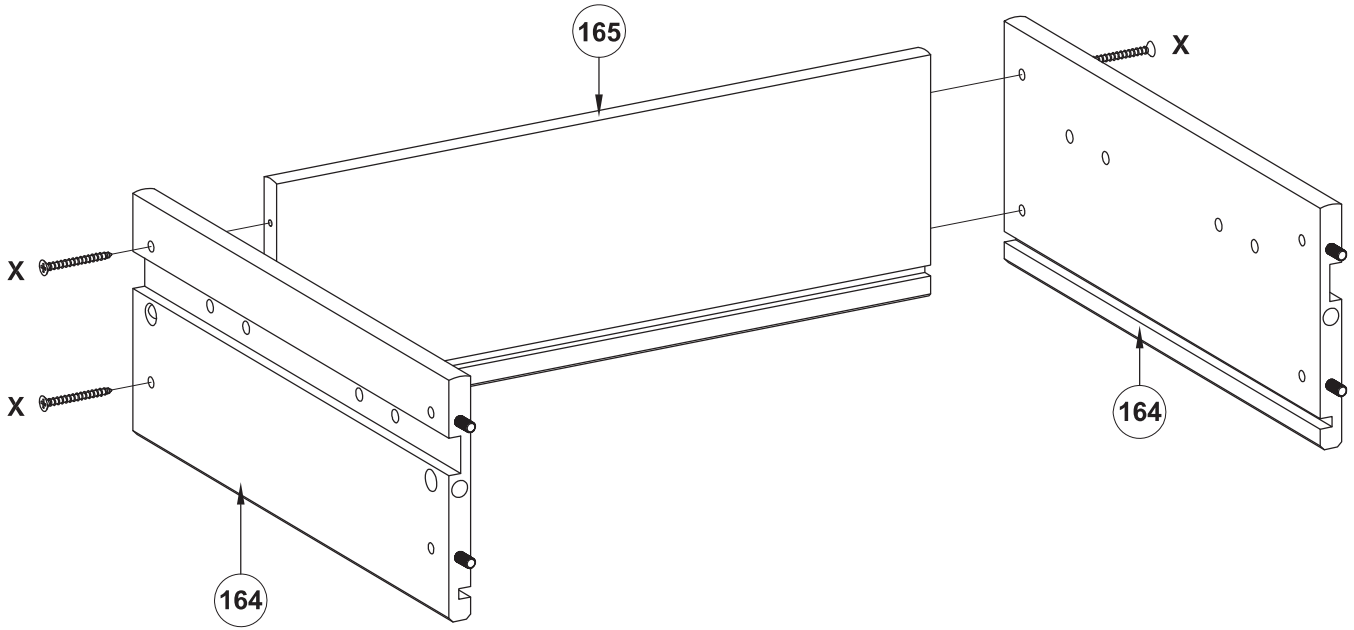
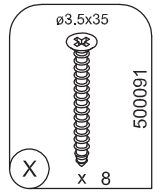

2 x

29

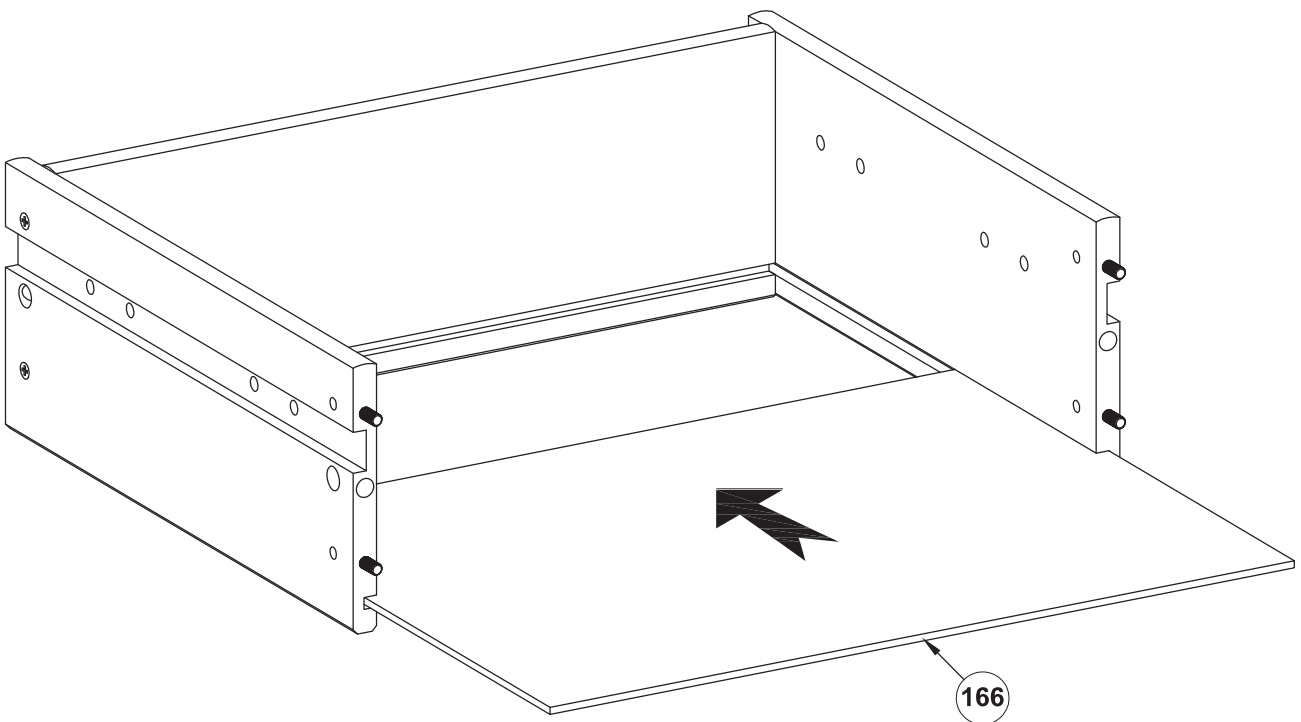

2 x

30

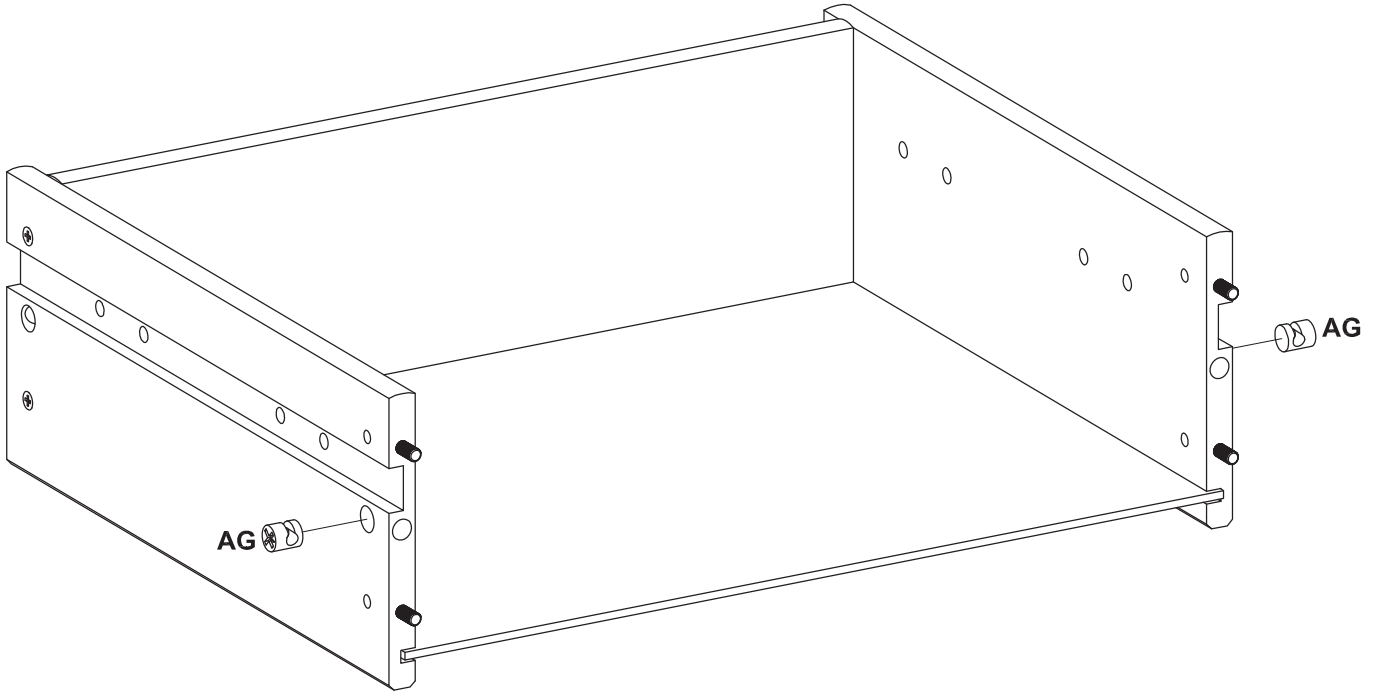
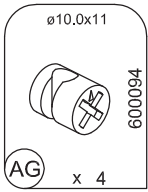

2 x

31

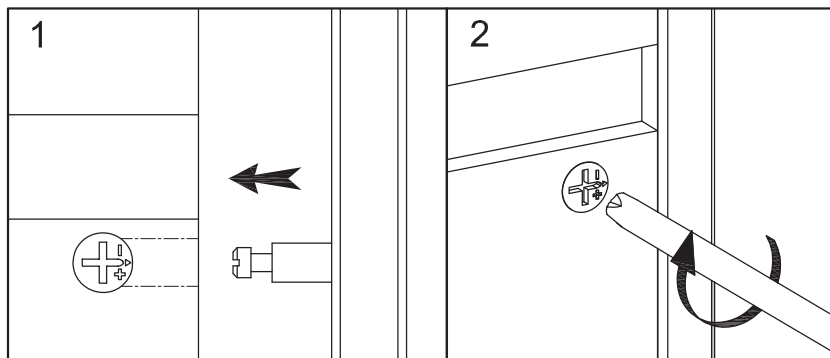
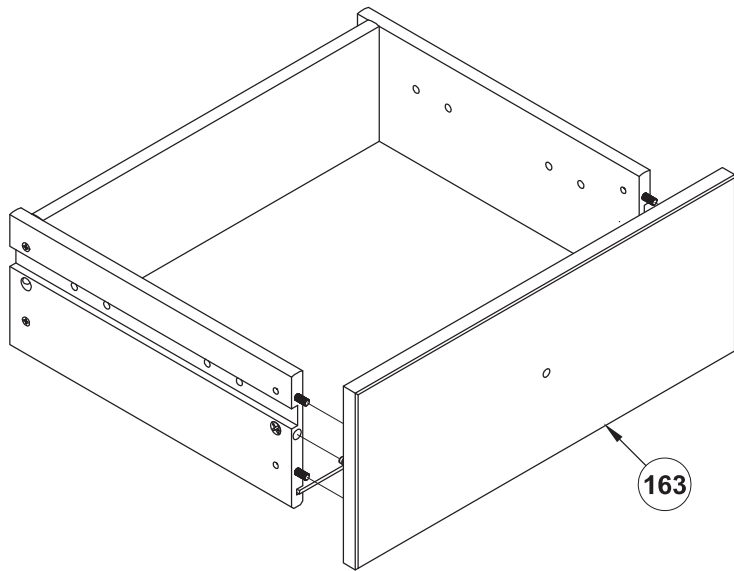

2 x

32

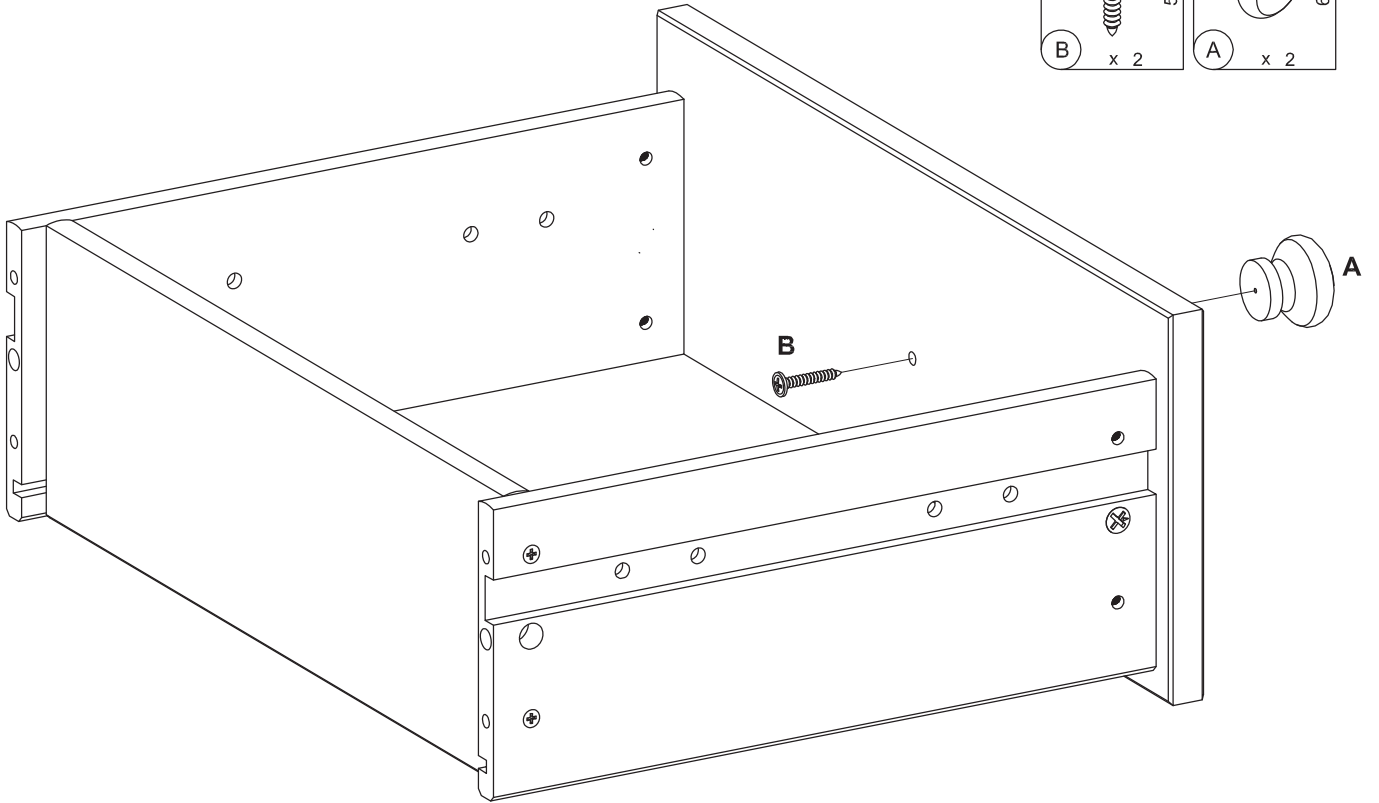
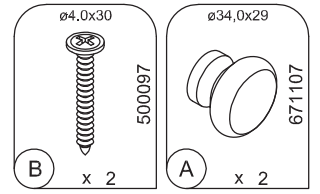

2 x

33

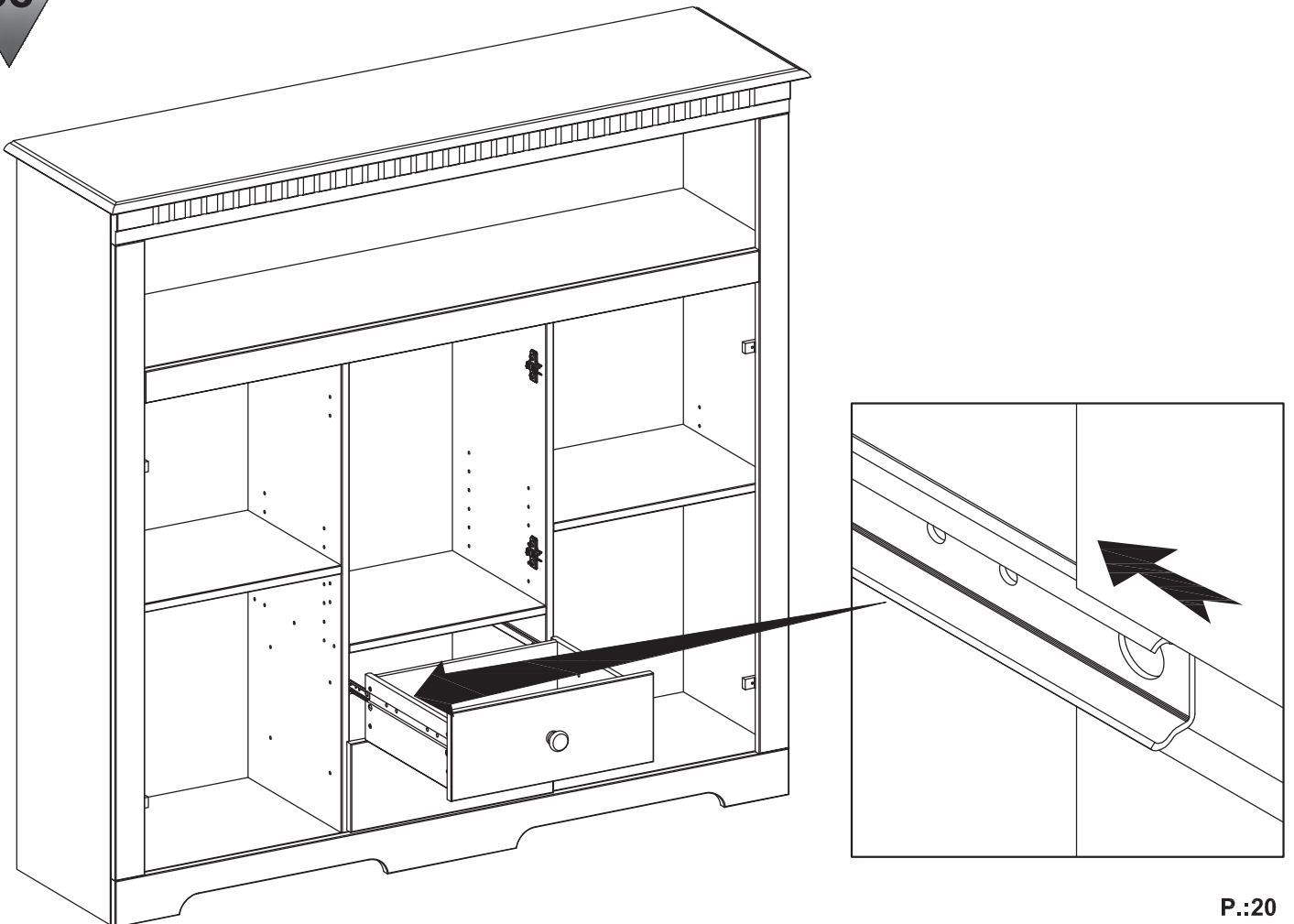

34

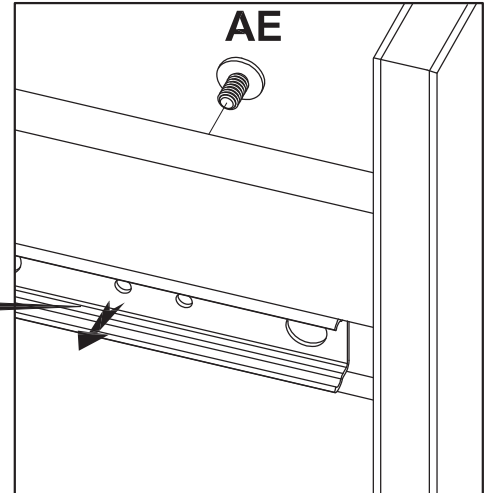
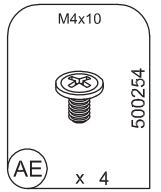
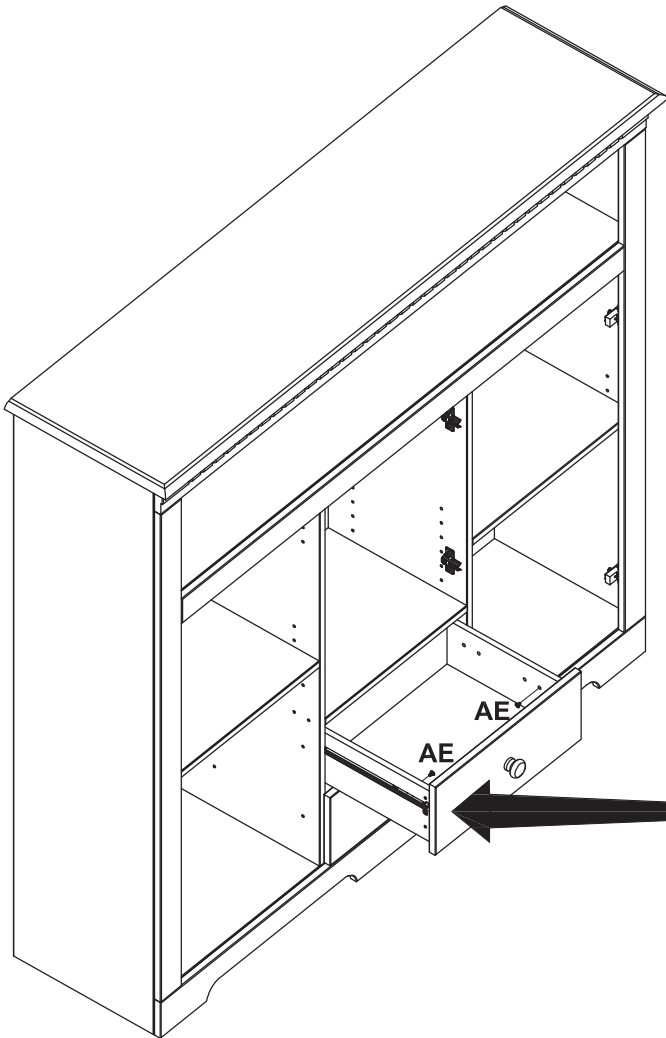

35

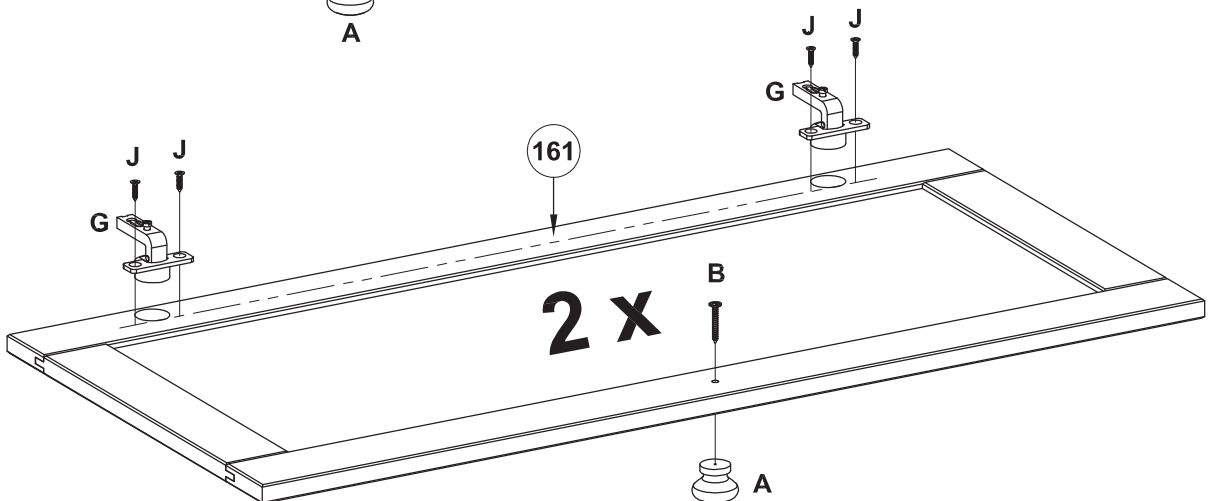
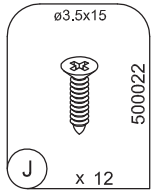
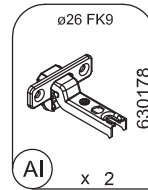
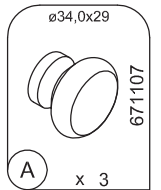
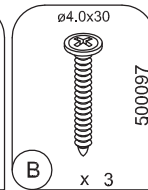
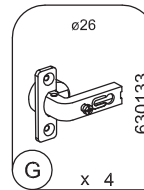
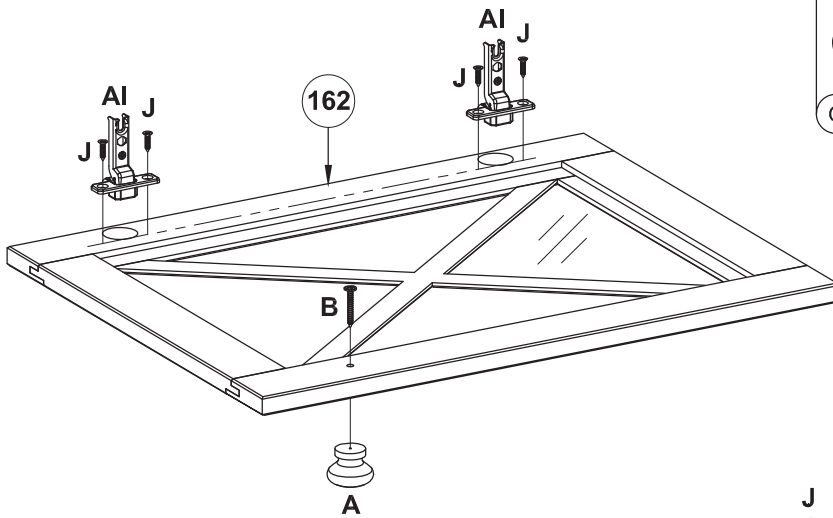

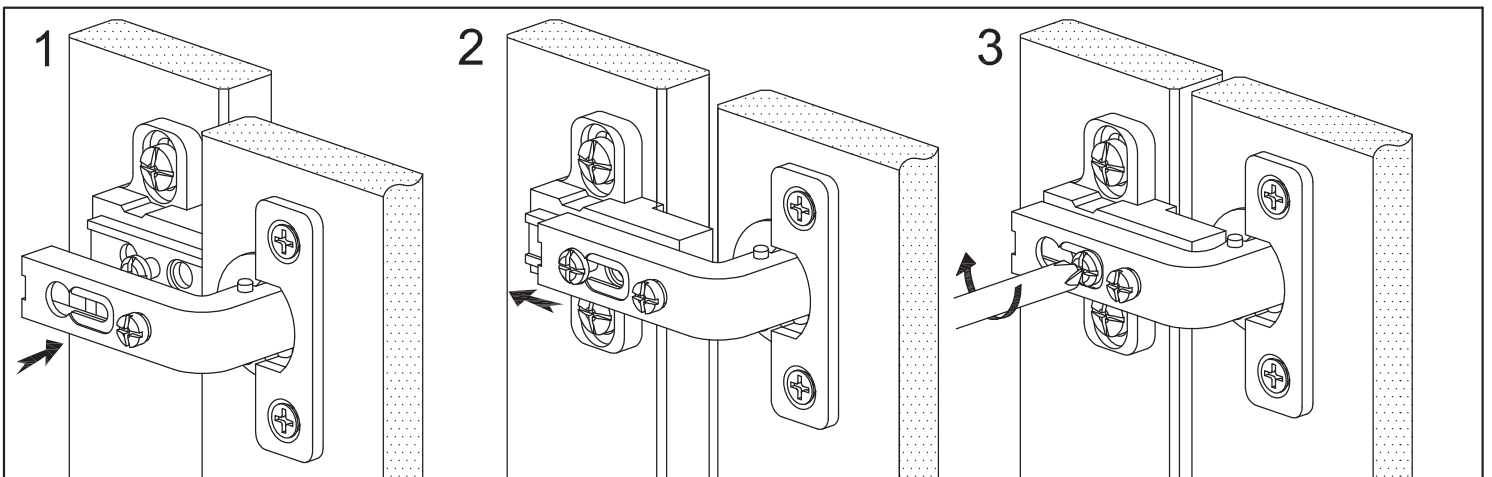
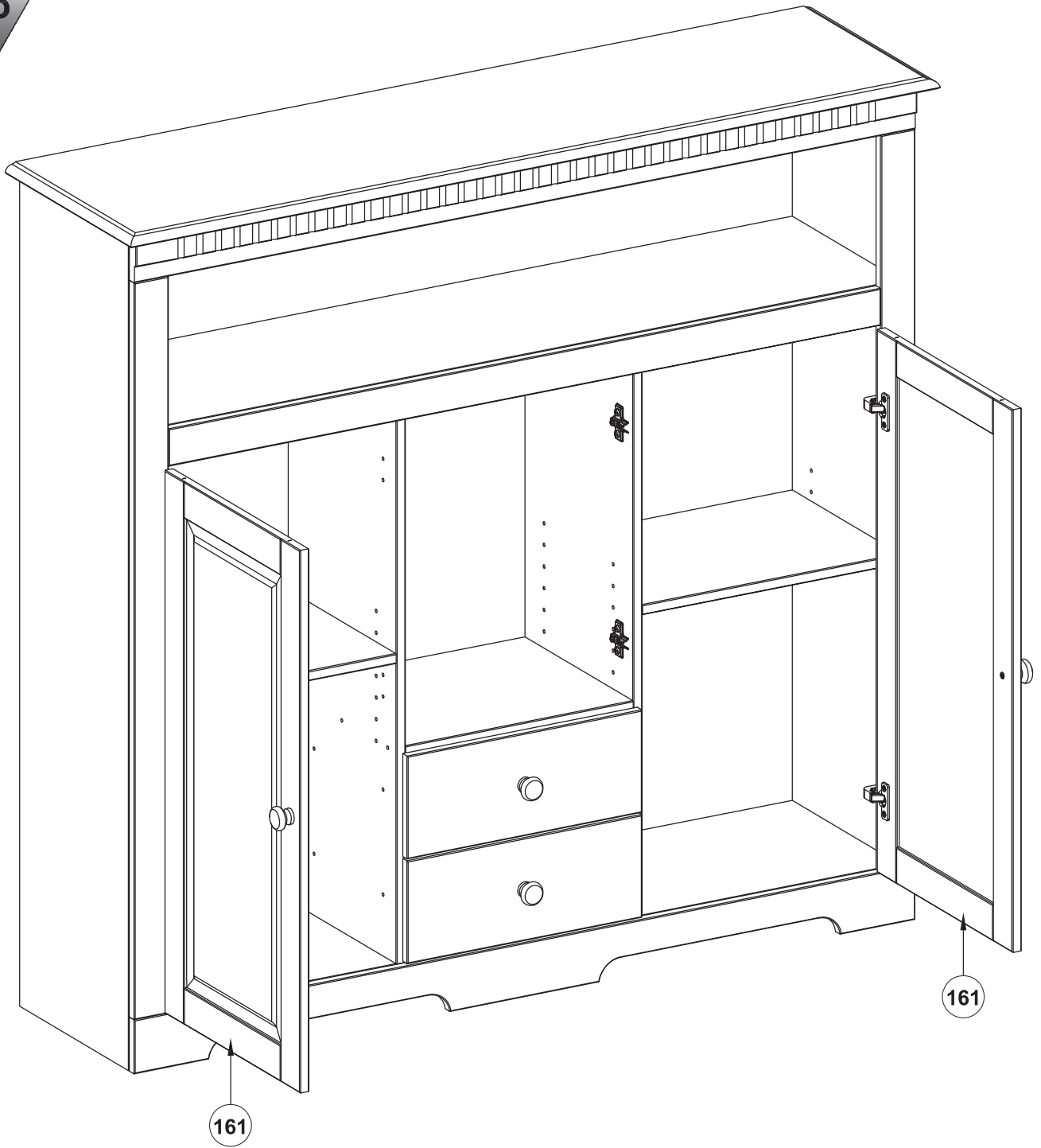



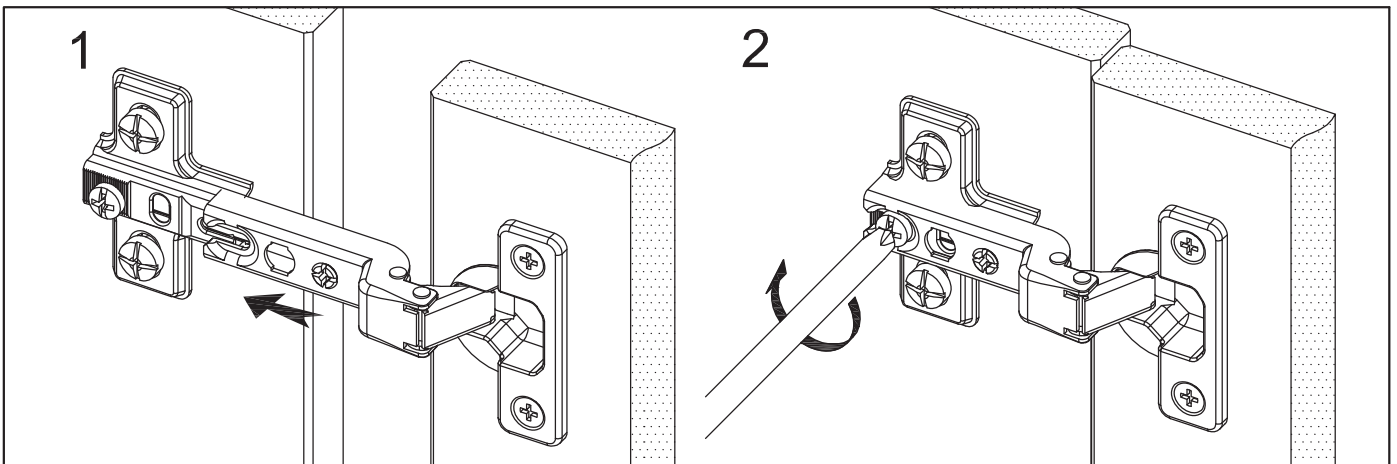
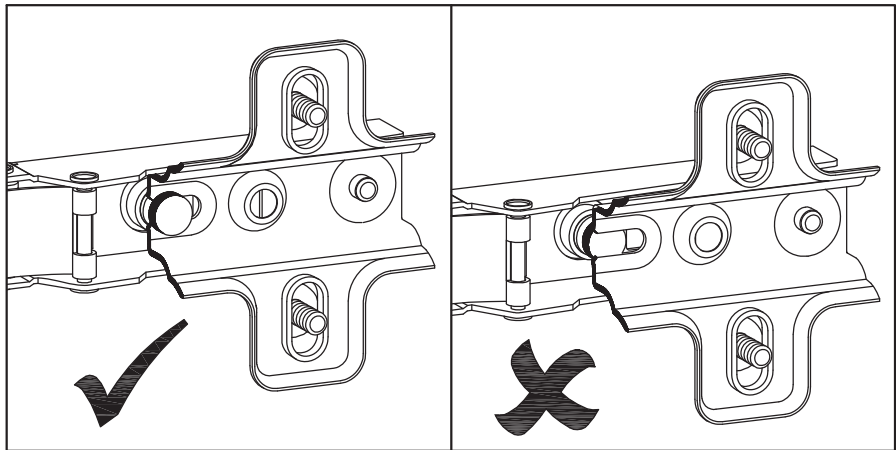
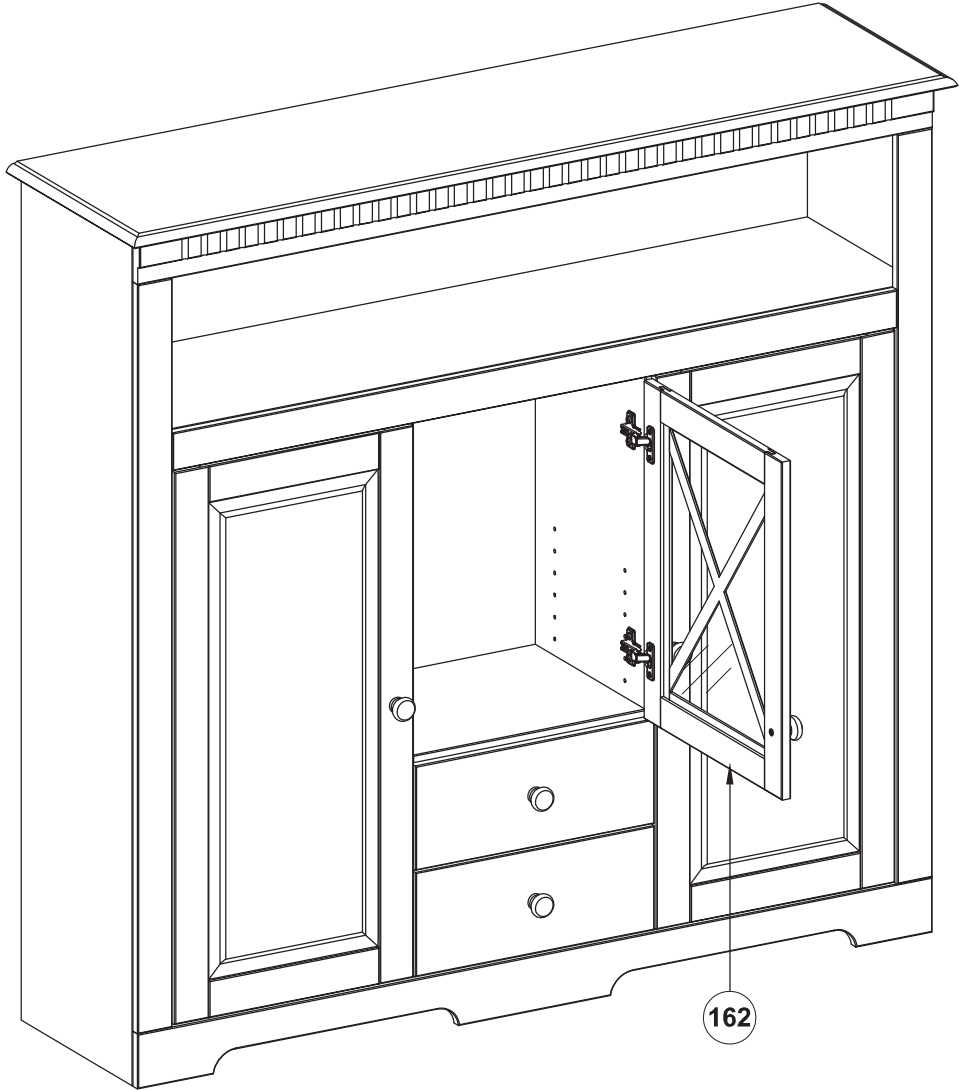

Türen einstellen (Scharniere justieren)  
Adjusting the doors (adjusting the hinges)

Régler les portes (ajuster les charnières)

Sistemare le porte (regolare le cerniere)

Deuren instellen (scharnieren afstellen)

Nastawić drzwi (wyregulować zawiasy)

Vyrovnejte dvířka (seřid'te závěsy)

Nastavenie dverí (nastavenie závesov)

Állítsa be az ajtókat (állítsa be a zsanérokot)

Reglare ușii (ajustare balamale)

Капıların ayarlanması (menteşelerin seviye ayarı)

Регулировка Дверей (регулировка шарнира)

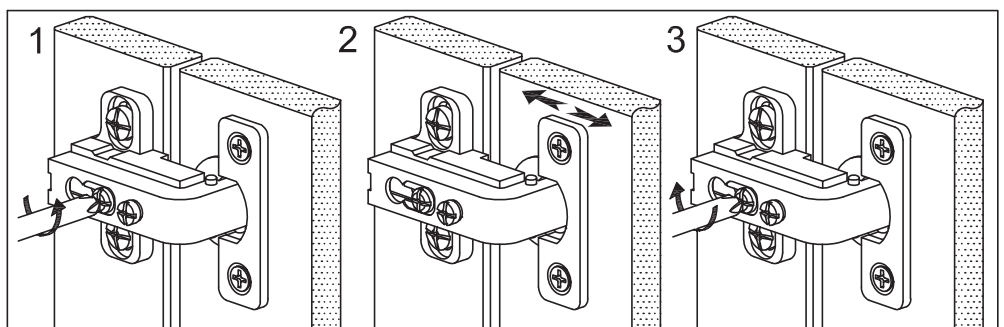
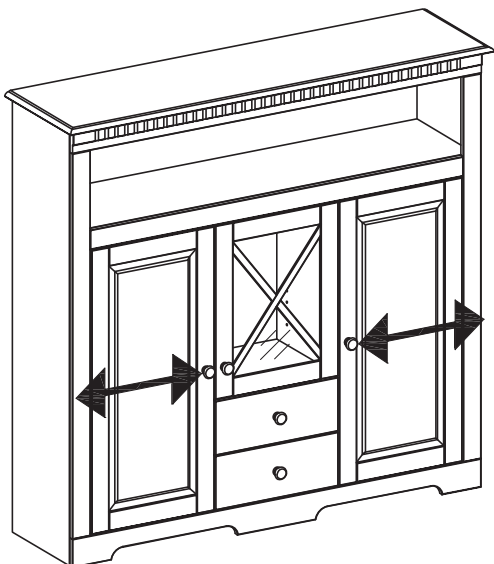
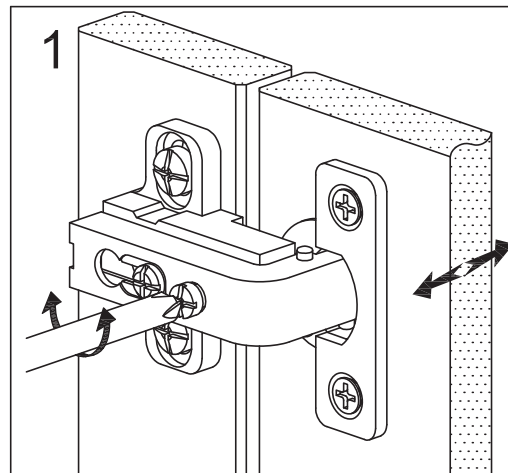
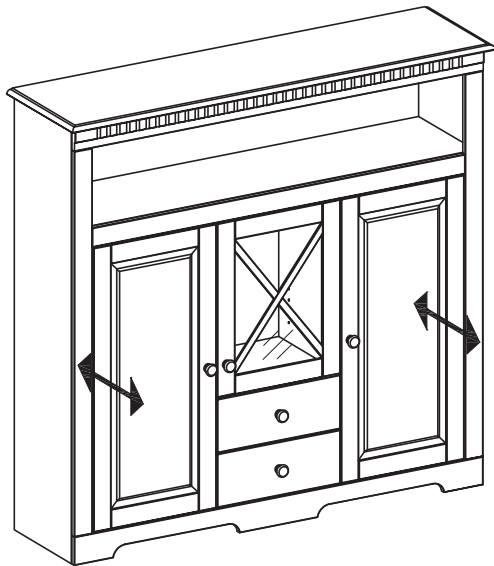
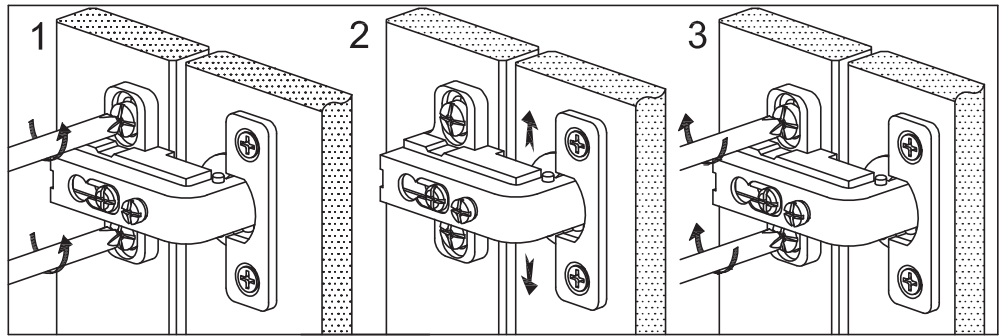
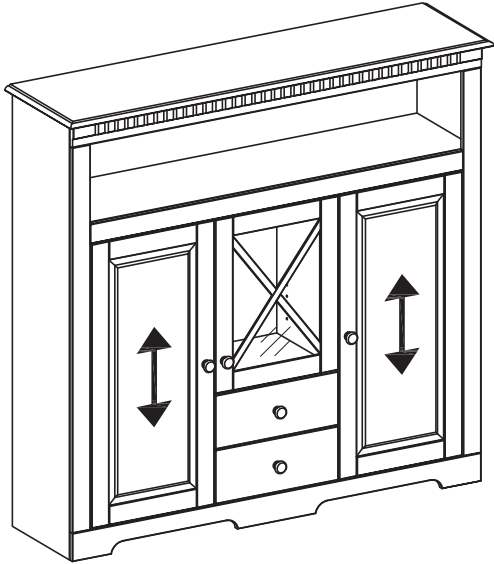

Türen einstellen (Scharniere justieren)  
Adjusting the doors (adjusting the hinges)

Régler les portes (ajuster les charnières)

Sistemare le porte (regolare le cerniere)

Deuren instellen (scharnieren afstellen)

Nastawić drzwi (wyregulować zawiasy)

Vyrovnejte dvířka (seřid'te závěsy)

Nastavenie dverí (nastavenie závesov)



Állítsa be az ajtókat (állítsa be a zsanérokot)

Reglare uși (ajustare balamale)

Капıların ayarlanması (menteşelerin seviye ayarı)

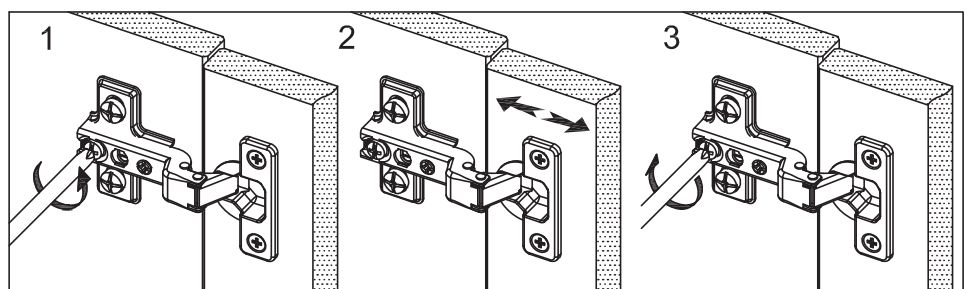
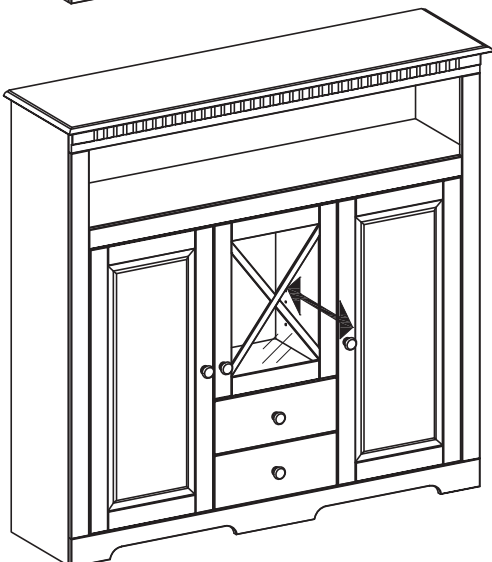
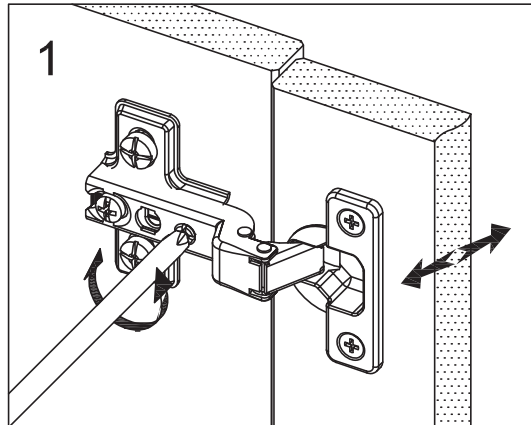
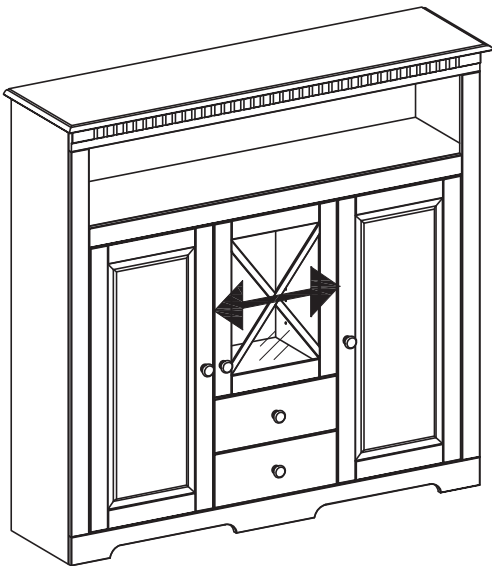
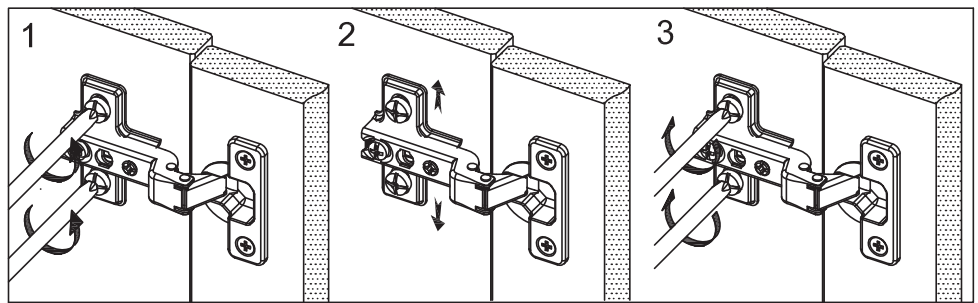
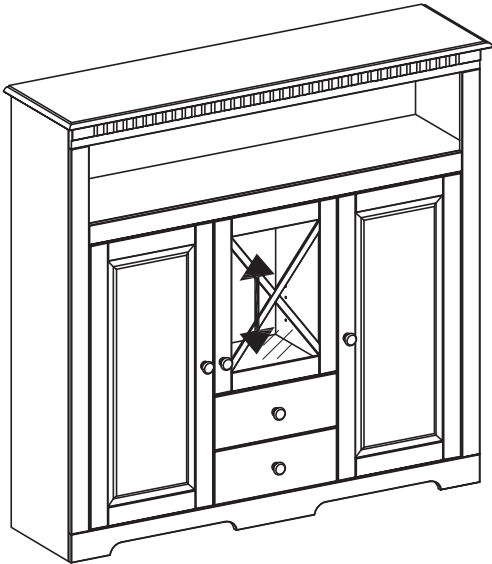
Регулировка Дверей (регулировка шарнира)



 <b>Achtung • Attention • Attenzione</b> <b>Opgelet • Uwaga • Pozor • Figyelem</b> <b>Atenție • Dikkat • Внимание</b> 	
<b>(D)</b>	Wandbefestigung dient als Kippschutz – unbedingt anbringen! Bei einigen Wandtypen kann ein Spezialdübel erforderlich sein!
<b>(GB)</b>	The wall fastening serves to prevent tipping – be absolutely sure to mount it! For certain wall types, a special wall plug may be necessary!
<b>(FR)</b>	La fixation murale sert de protection contre le basculement – à installer impérativement ! Pour certains types de murs il faut des chevilles spéciales !
<b>(IT)</b>	Il fissaggio alla parete serve da protezione anti-ribaltamento – attaccarla assolutamente! Per alcune strutture di parete può essere necessario un tassello speciale!
<b>(NL)</b>	Bevestiging aan de muur dient als kantelbescherming – zeker en vast bevestigen! Bij enkele muurtypen is een speciale plug misschien vereist!
<b>(PL)</b>	Mocowanie do ściany jest jednocześnie zabezpieczeniem przed przewróceniem – koniecznie zamontować! Do niektórych rodzajów ścian konieczne zastosować specjalne kołki mocujące.
<b>(CZ)</b>	Montáž na stěnu slouží jako ochrana proti převrnutí – bezpodmínečně umístěte! U některých typů stěn může být zapotřebí speciální hmoždinka!
<b>(SK)</b>	Upevnenie na stenu slúži ako ochrana proti prevráteniu – bezpodmienečne použite! Pre niektoré druhy stien môže byť potrebná špeciálna hmoždinka!
<b>(HU)</b>	A terméket a falhoz kel rögzíteni, különben az felborulhat! Egyes faltípusoknál speciális tiplit kell használni!
<b>(RO)</b>	Sistemul de fixare la perete servește ca protecție la răsturnare – de montat obligatoriu! Pentru unele tipuri de pereți este posibil să fie necesar un diblu special!
<b>(TR)</b>	Duvardaki sabitleme, devrilmeye karşı bir emniyet tedbiridir ve mutlaka monte edilmelidir! Bazı duvar tiplerinde bunun için özel dibel gerekli olabilir!
<b>(RU)</b>	Обязательно установите крепление на стене во избежание опрокидывания! Для некоторых типов стен может потребоваться специальный дюбель!

