

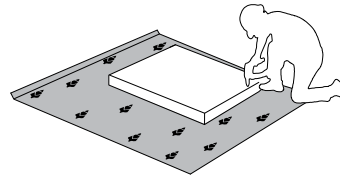

**VAŽNO – PŘE UPOTREBE PAŽLJIVO PROČÍTAJTE I SAČUVAJTE UPUTSTVO**  
**IMPORTANT – READ CAREFULLY – RETAIN FOR FUTURE REFERENCE**  
**WICHTIG – SORGFÄLTIG LESEN UND AUFBEWAHREN**  
**ВАЖНО – ПРОЧИТИТЕ ВНИМАТЕЛЬНО – СОХРАНИТЬ ДЛЯ ДАЛЬНЕЙШЕГО ИСПОЛЬЗОВАНИЯ**  
**WAŻNE – PRZED UŻYCIEM NALEŻY DOKŁADNIE ZAPOZNAĆ SIĘ Z NINIEJSZĄ INSTRUKCJĄ I ZACHOWAĆ JĄ**  
**BELANGRIJK – LEES VOOR GEBRUIK DE INSTRUCTIES ZORGVULDIG DOOR EN BEWAAR ZE**  
**IMPORTANTE – PRIMA DELL'USO, LEGGERE ATTENTAMENTE E CONSERVARE LE ISTRUZIONI**  
**IMPORTANT – AVANT UTILISATION, LISEZ ATTENTIVEMENT ET CONSERVEZ LES INSTRUCTIONS**  
**ÖNEMLI – KULLANMADAN ÖNCE TALIMATLARI DİKKATLİCE OKUYUN VE SAKLAYIN**  
**IMPORTANT – ÎNAINTE DE UTILIZARE, CITIȚI CU ATENȚIE ȘI PĂSTRAȚI INSTRUCȚIUNILE**  
**DŮLEŽITÉ – PŘED POUŽITÍM SI PEČLIVĚ PŘEČTĚTE A USCHOVEJTE POKYNY**  
**DŐLEŽITÉ – PRED POUŽITÍM SI POZORNE PREČÍTAJTE A USCHOVAJTE NÁVOD**  
**FONTOS – HASZNÁLAT ELŐTT FIGYELMESEN OLVASSA EL ÉS ŐRIZZE MEG AZ UTASÍTÁSOKAT**

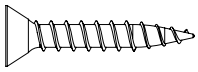

22. 04. 2024

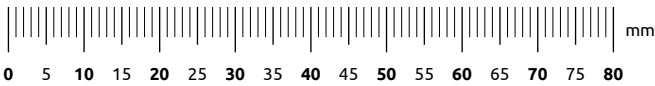
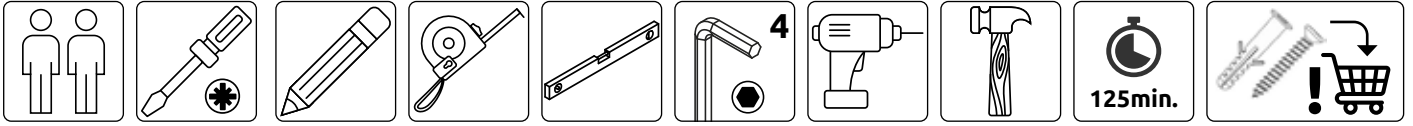
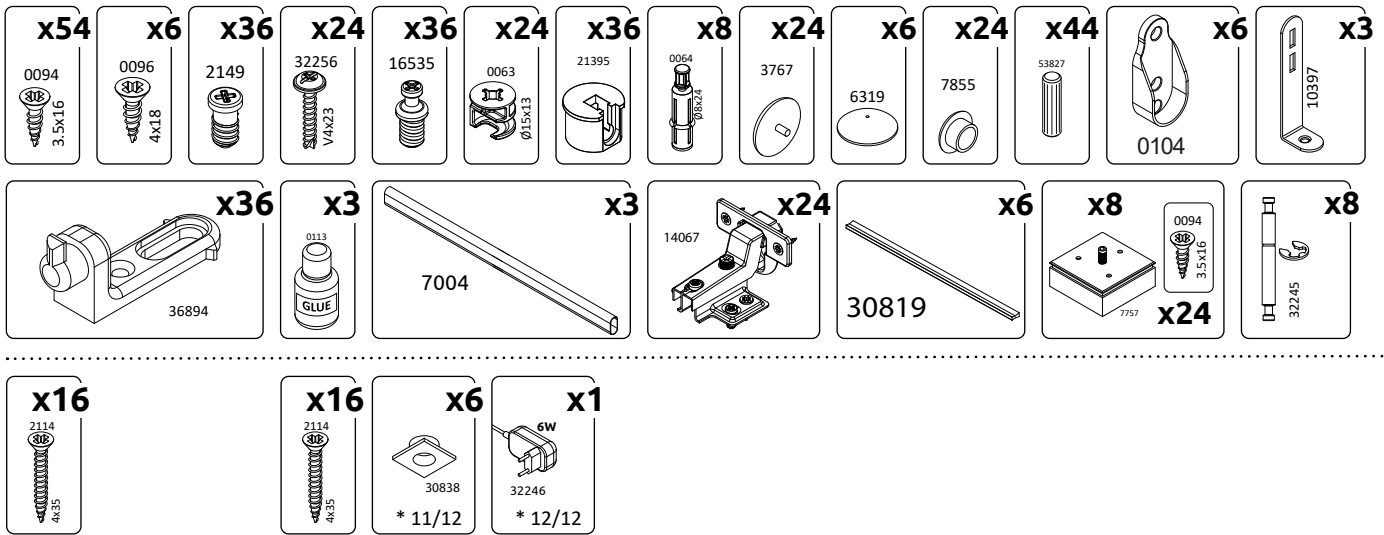

\* opt P6A/PN

\* opt P6B/PN

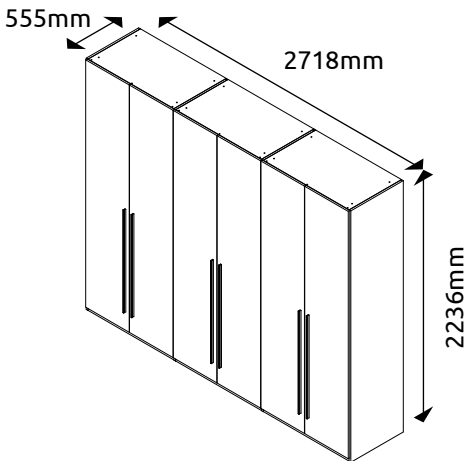

**P6/PN**  
LWH - 2718x555x2236

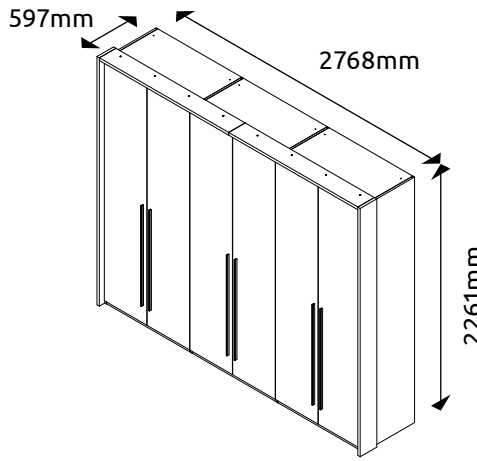

**P6A/PN**  
LWH - 2768x597x2261

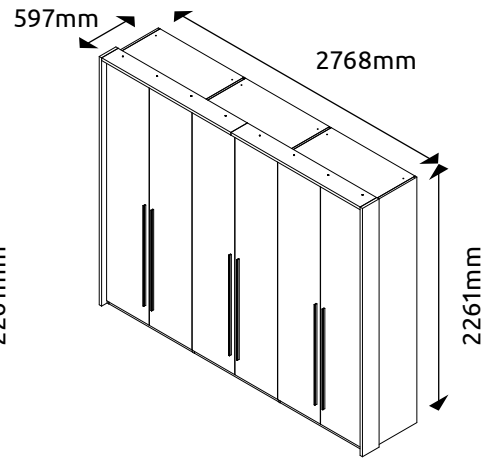

**P6B/PN**  
LWH - 2768x597x2261

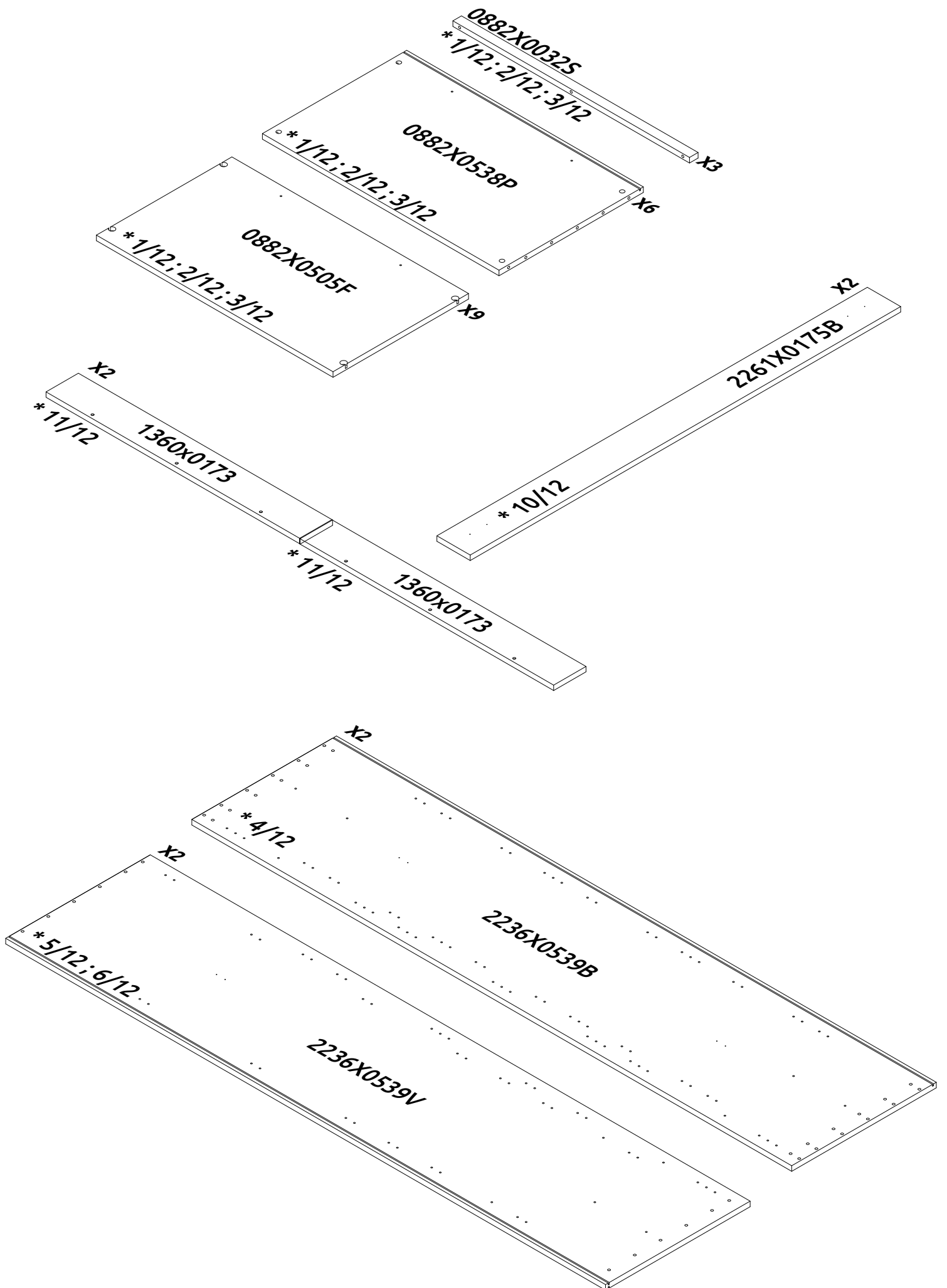

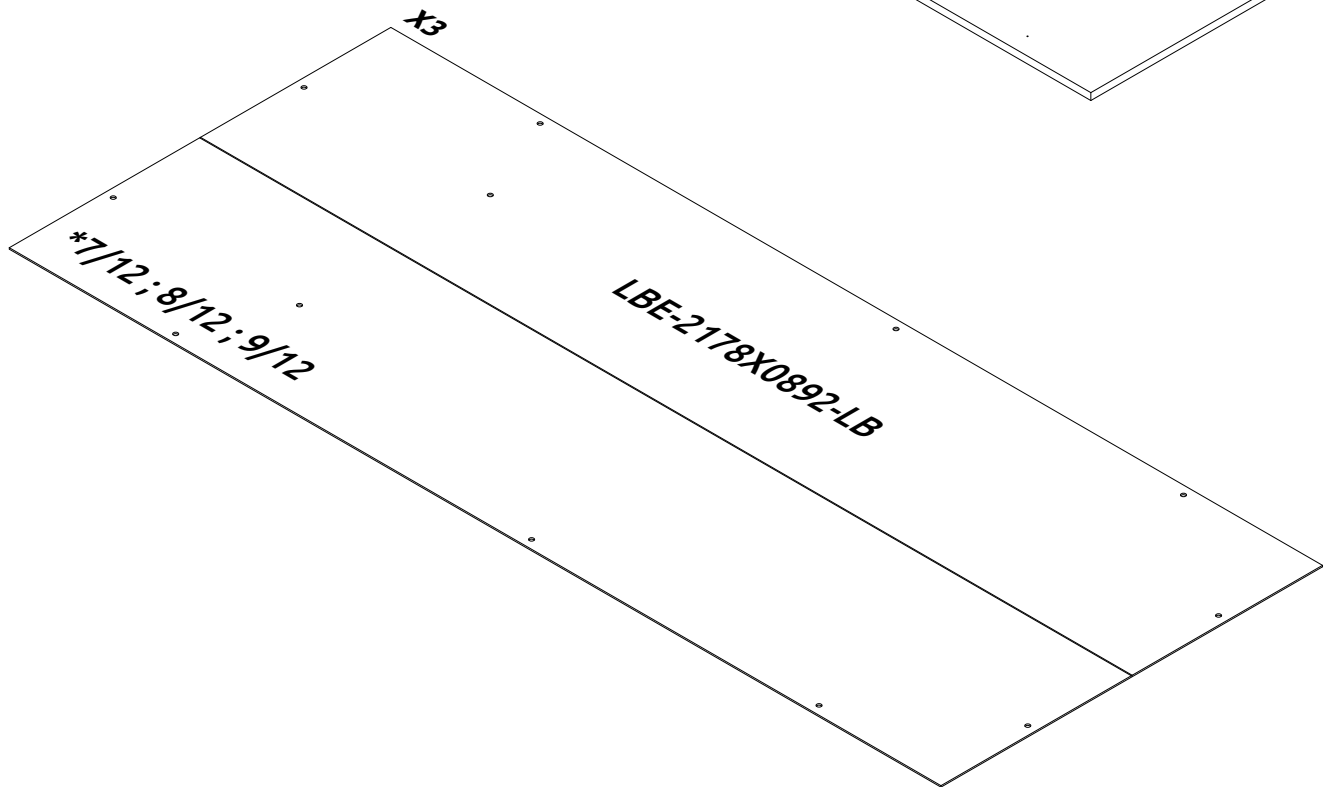
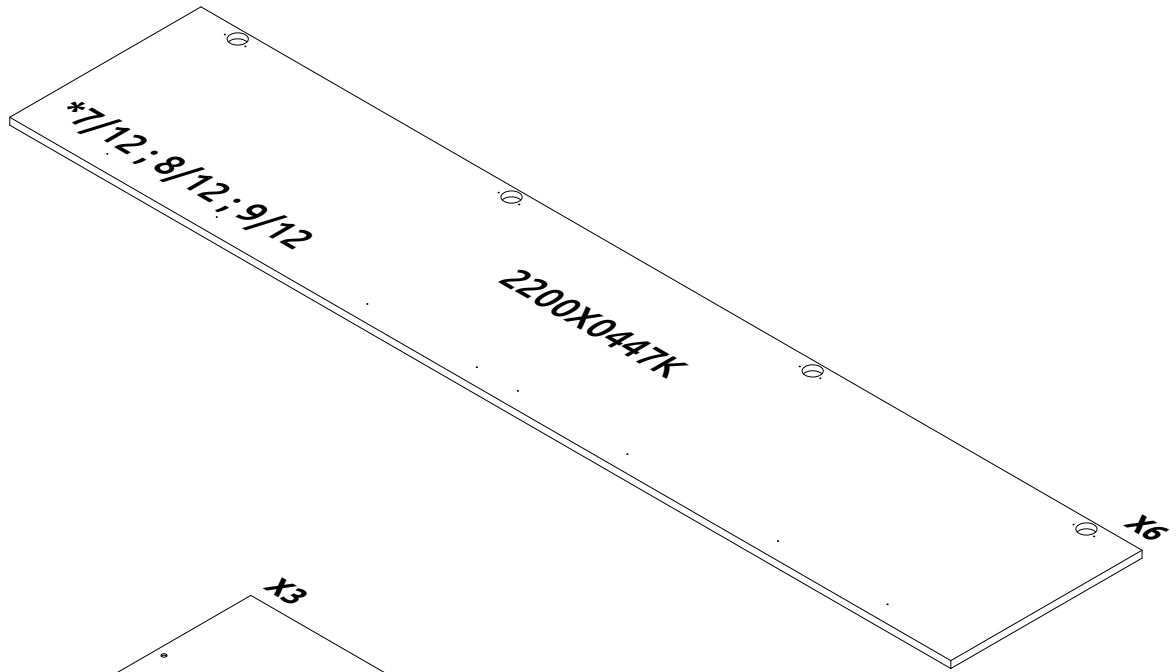

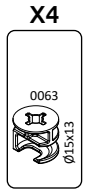

**1**

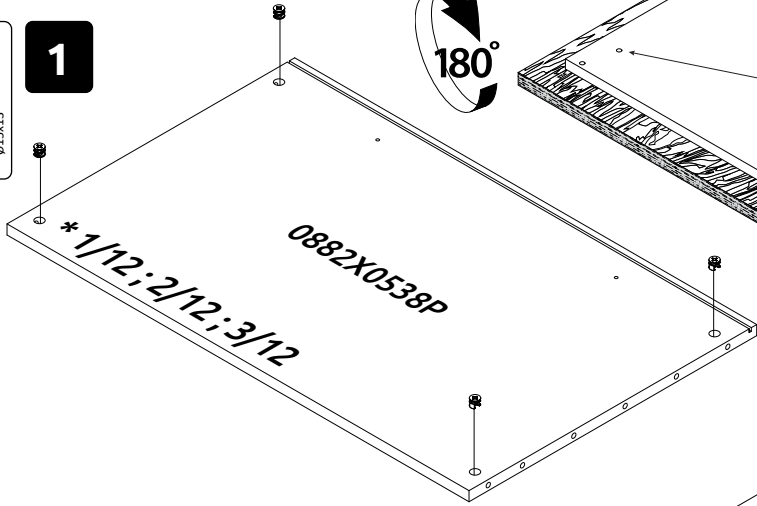

**2**

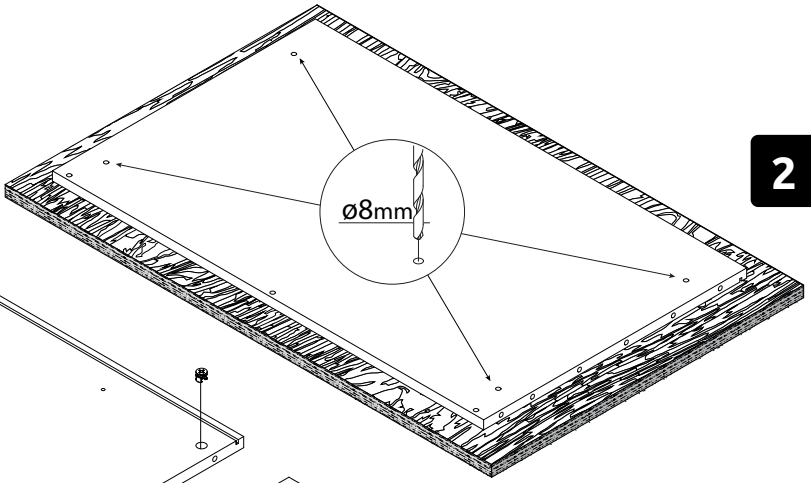

**3**

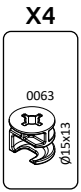
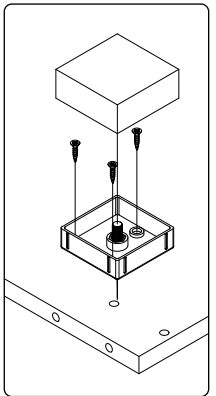
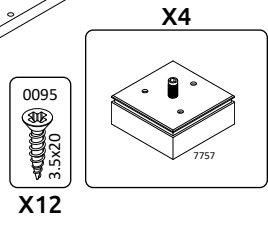
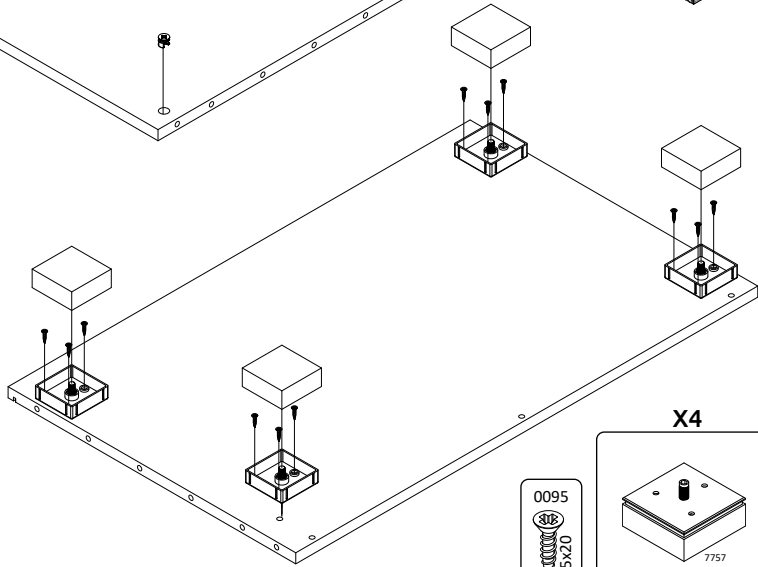

**4**

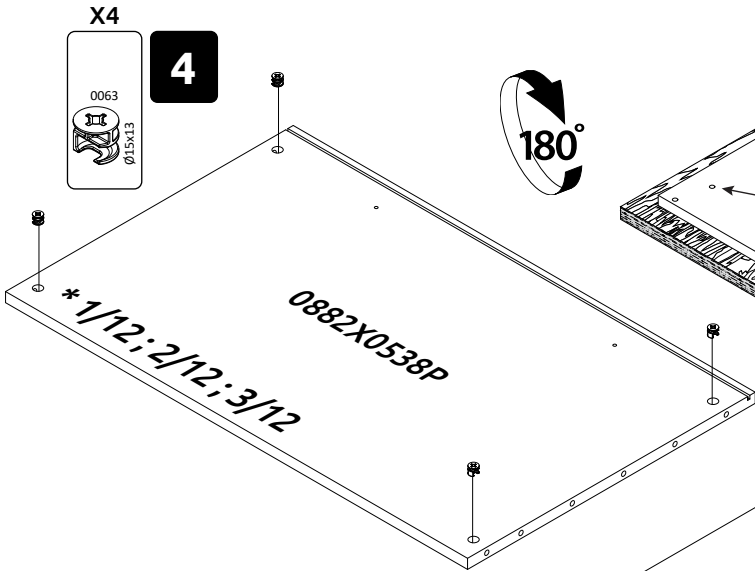

**5**

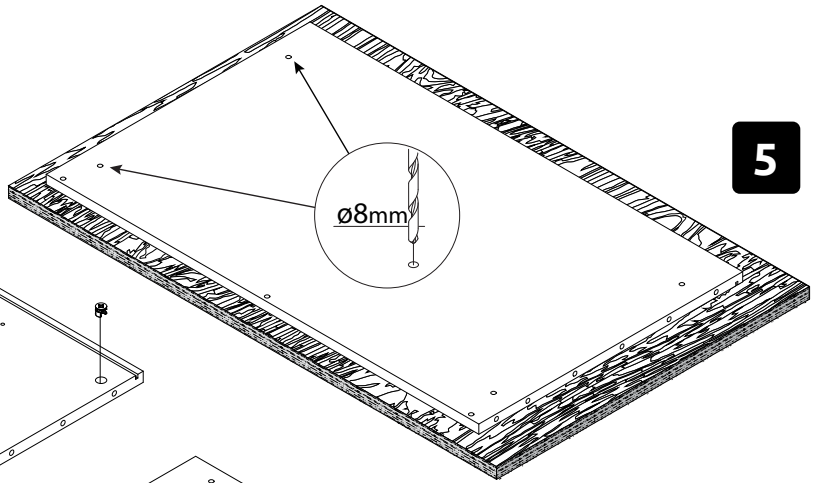

**6**

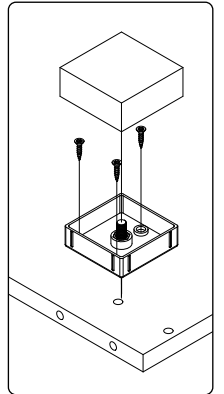
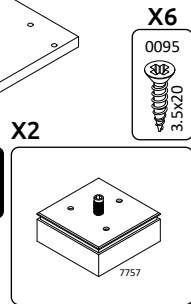
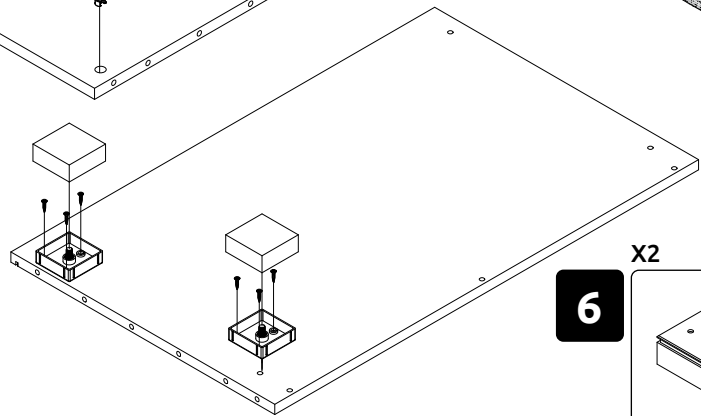

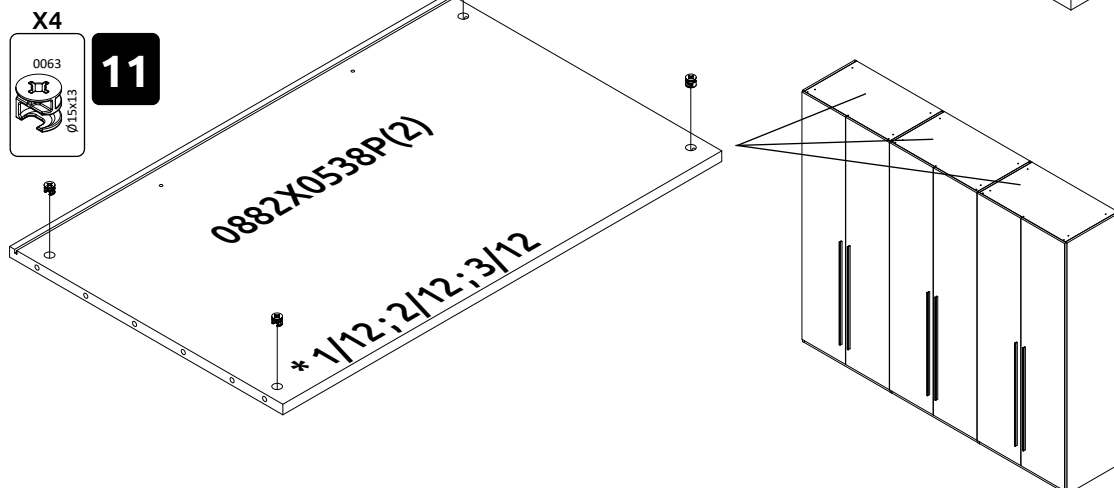
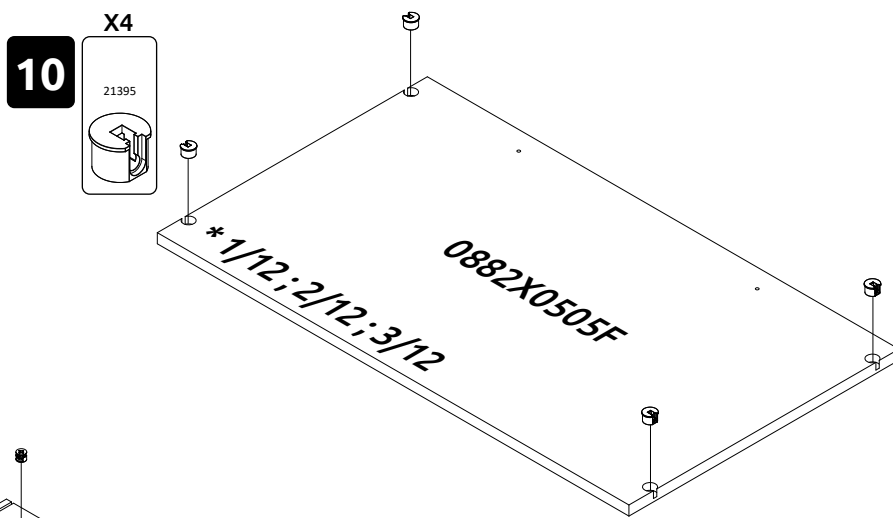
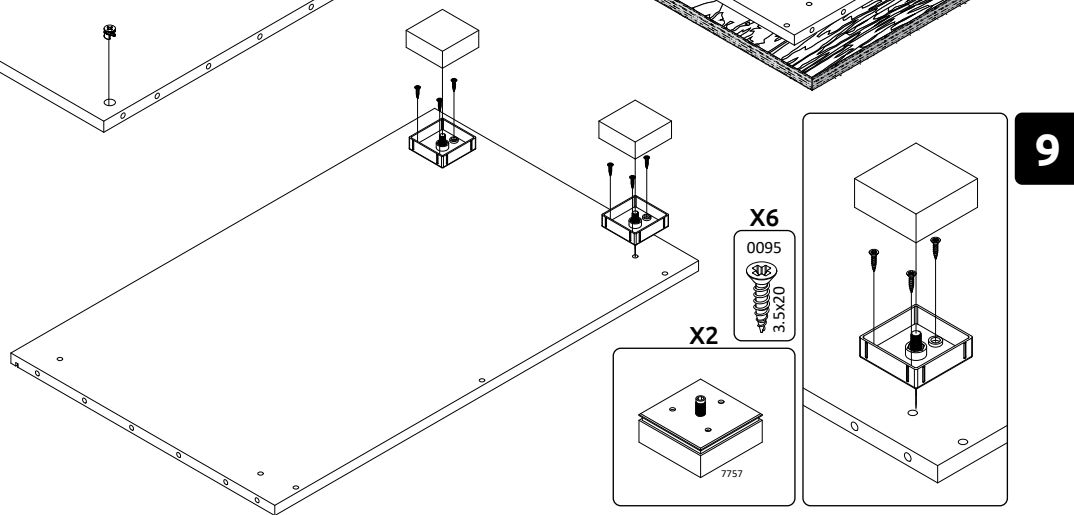
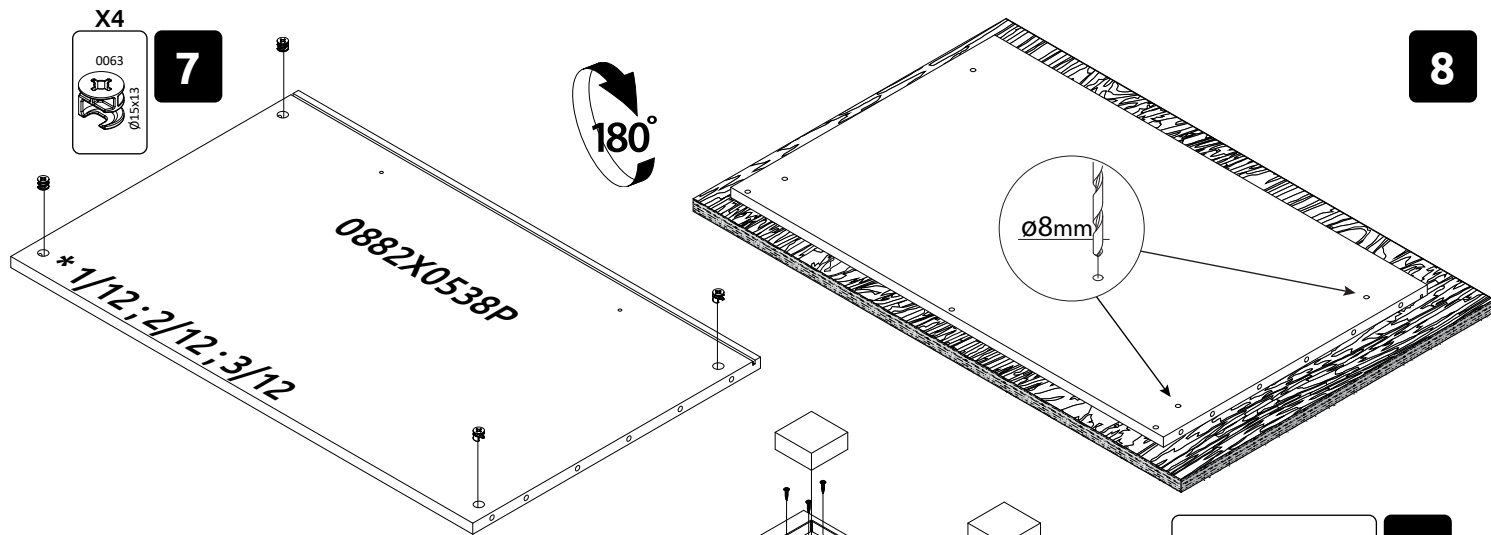

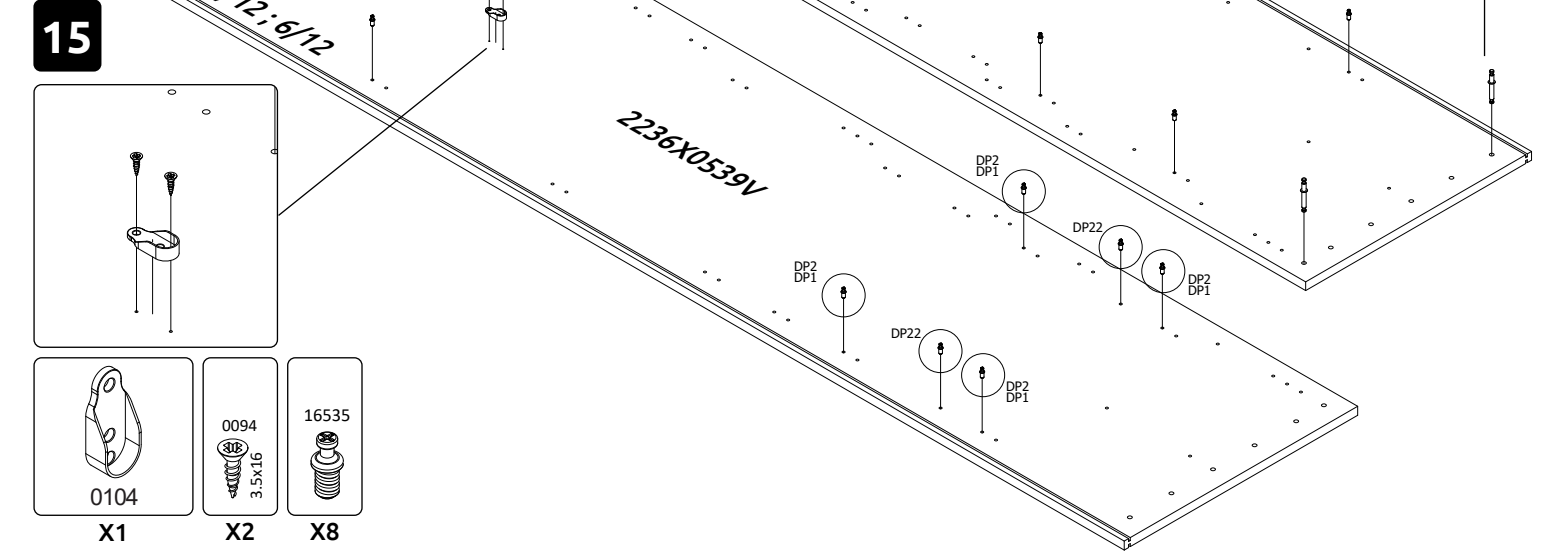
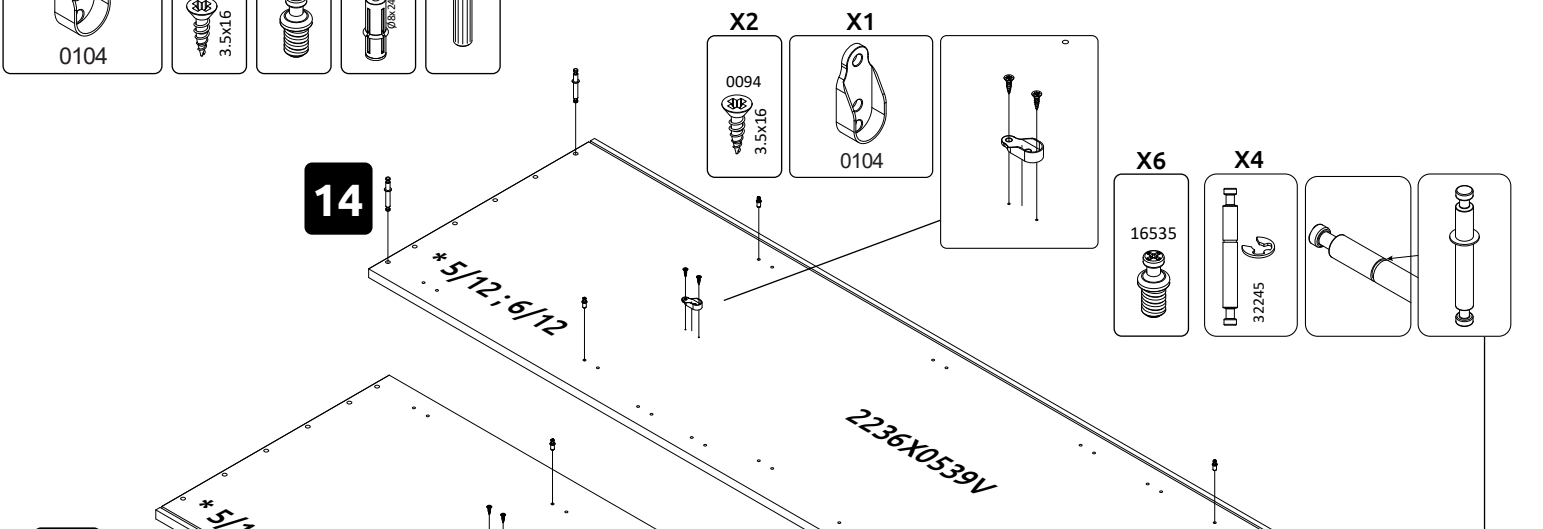
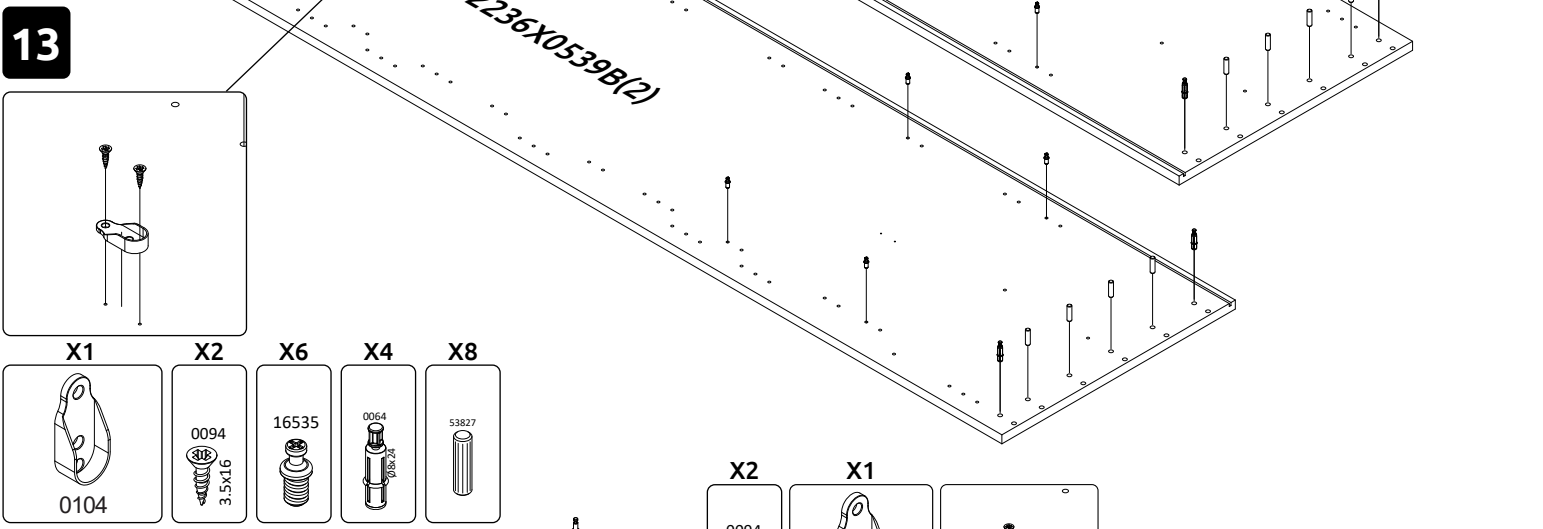
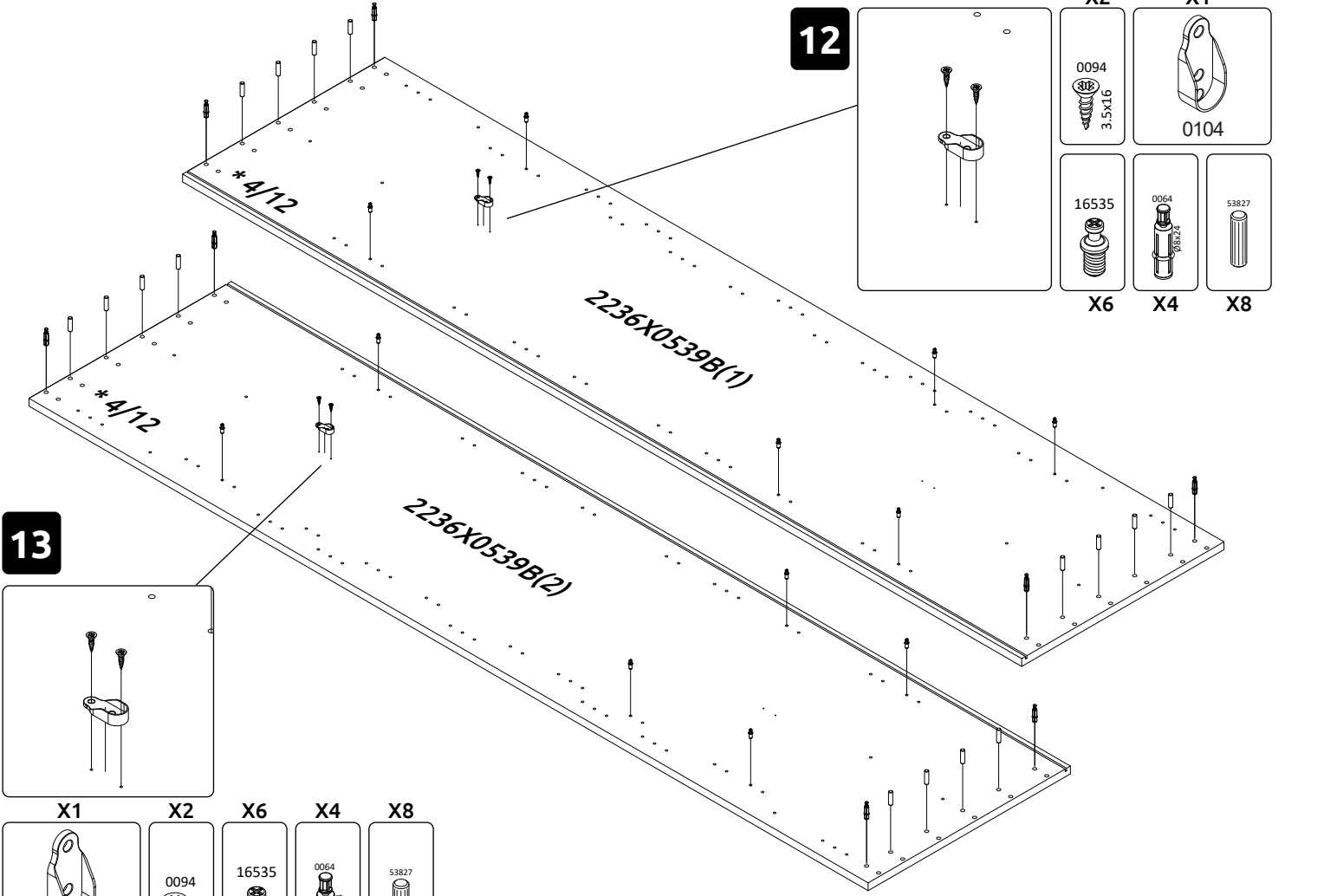

16

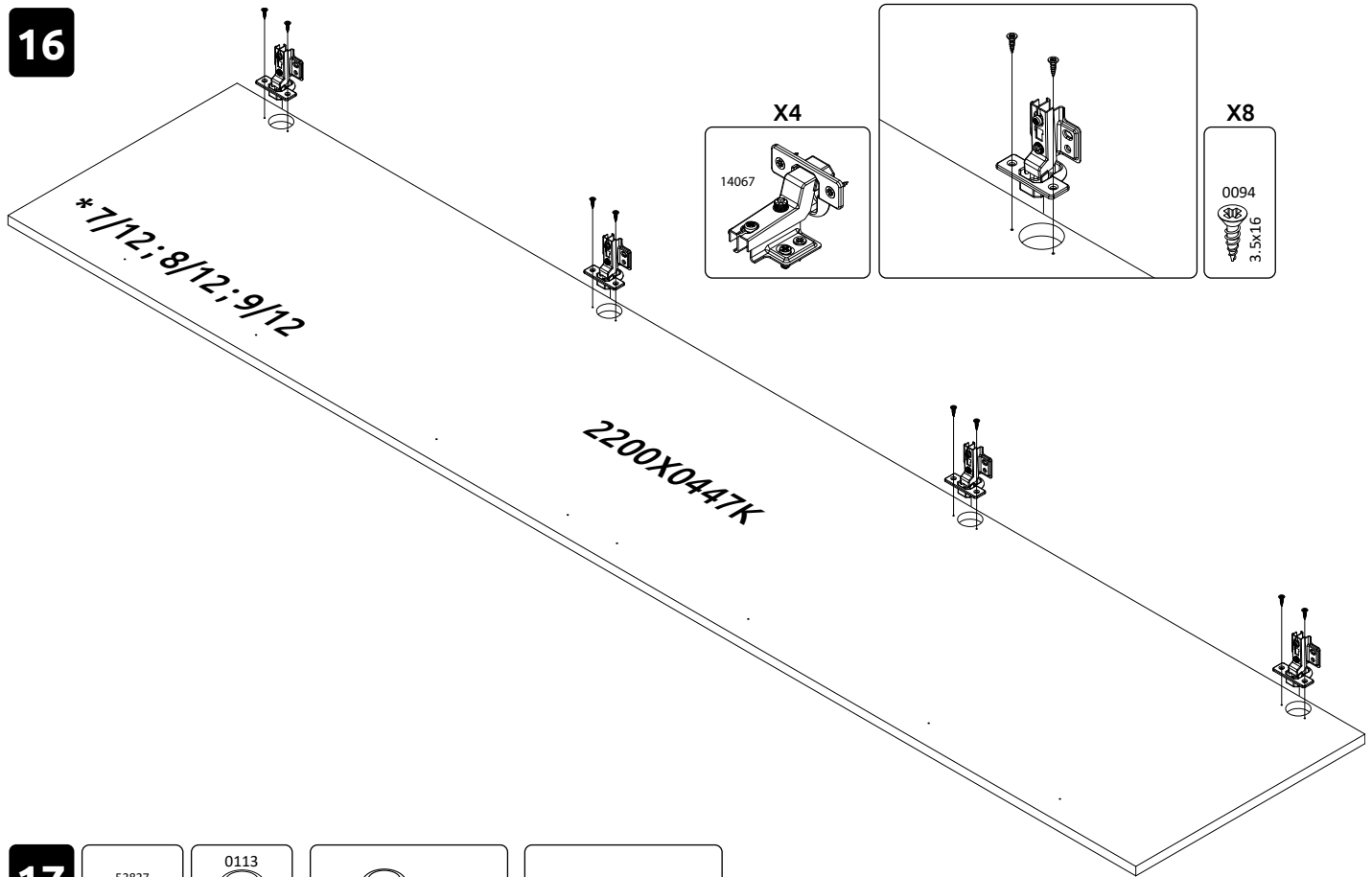

17

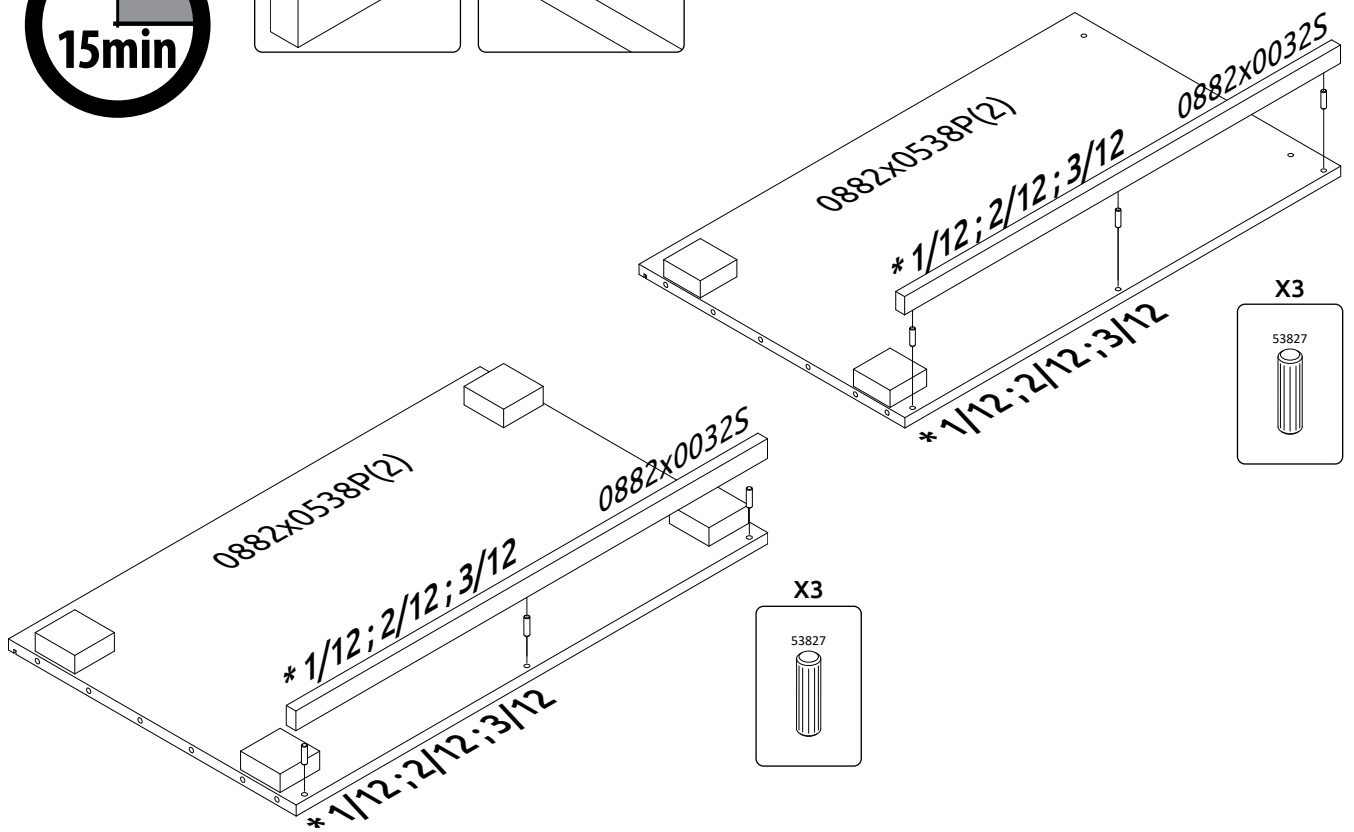
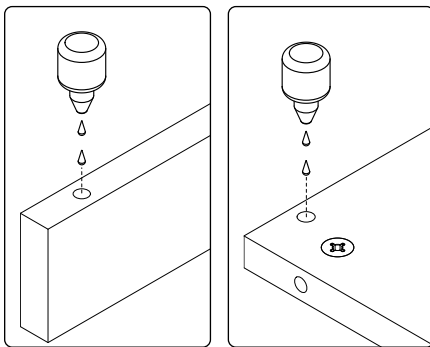
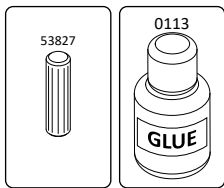

18

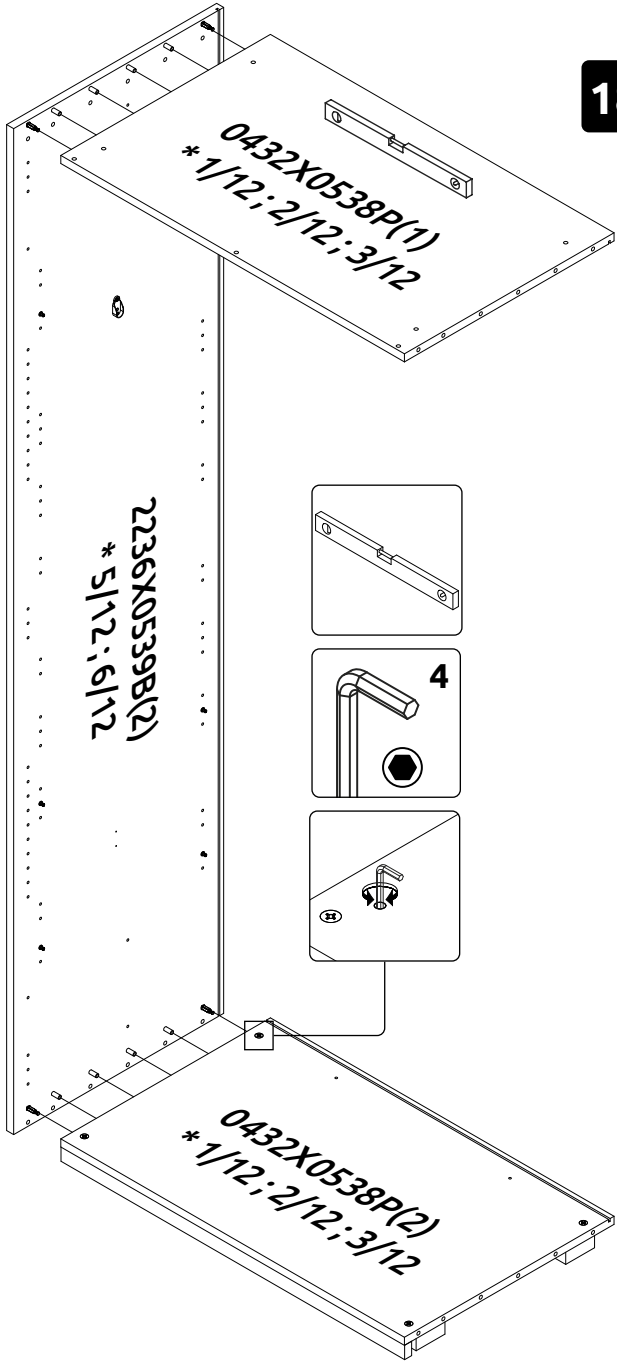
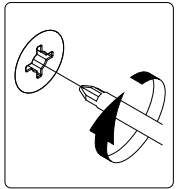

19

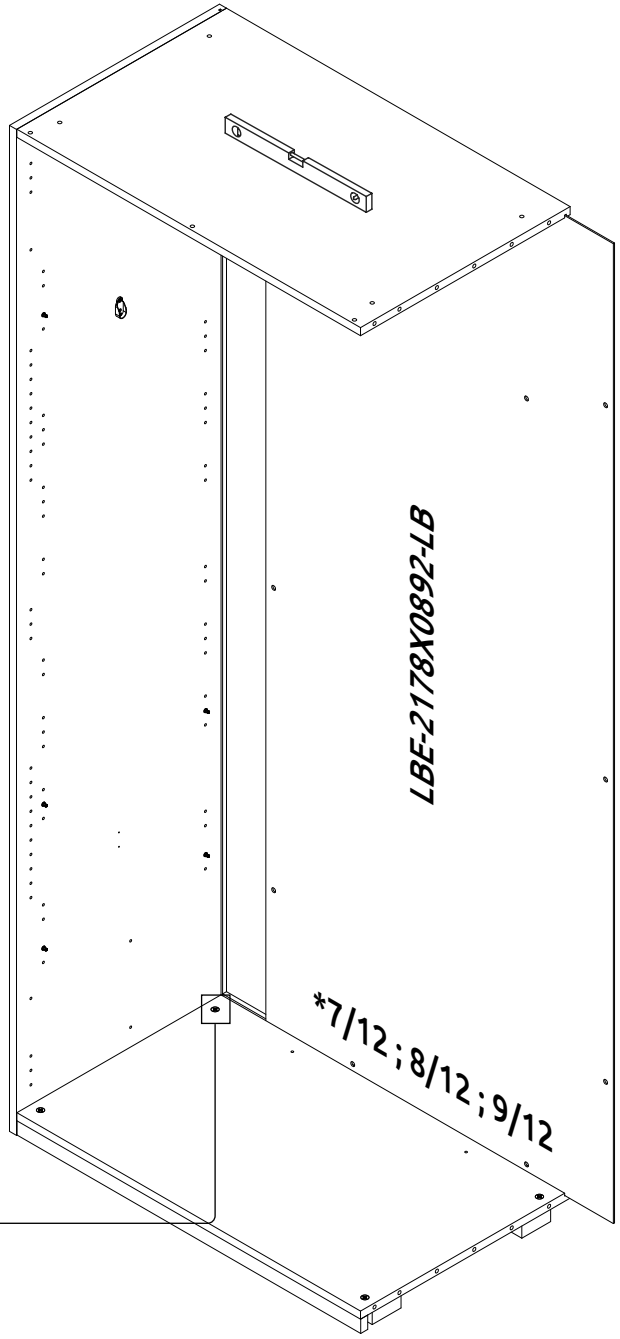
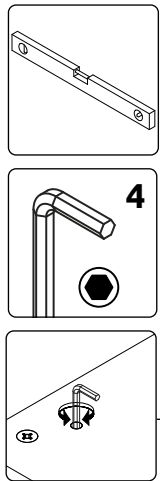



20

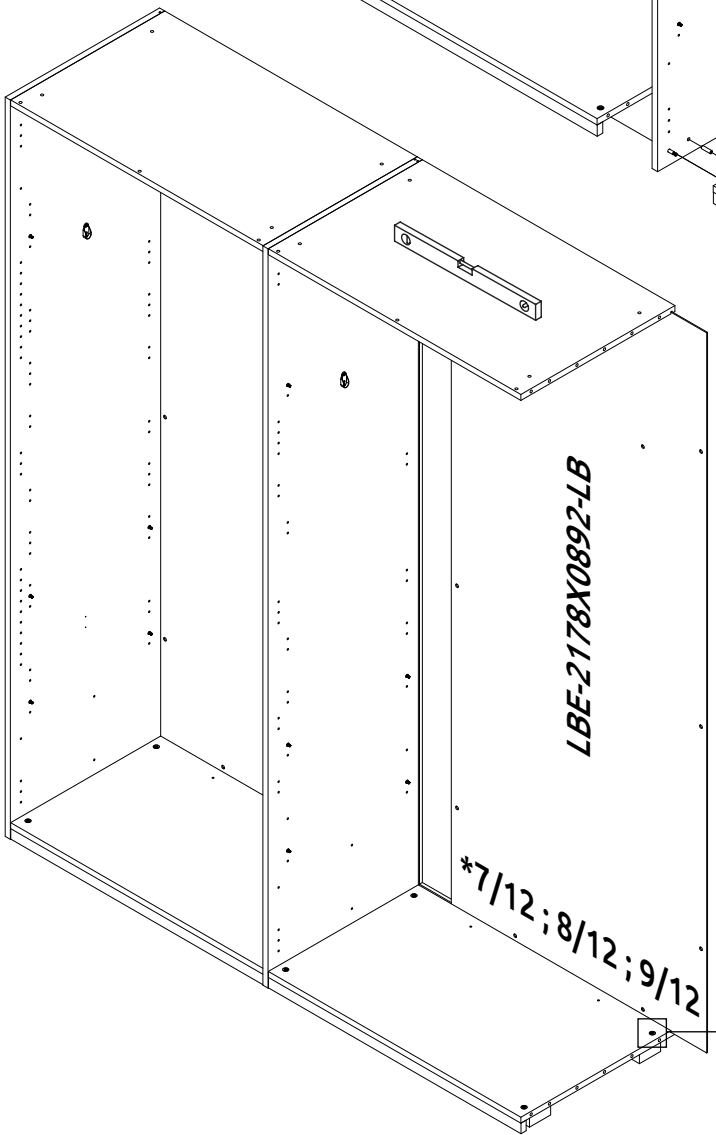
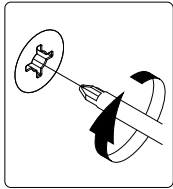
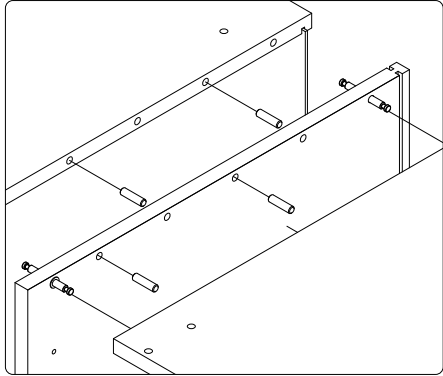
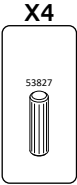
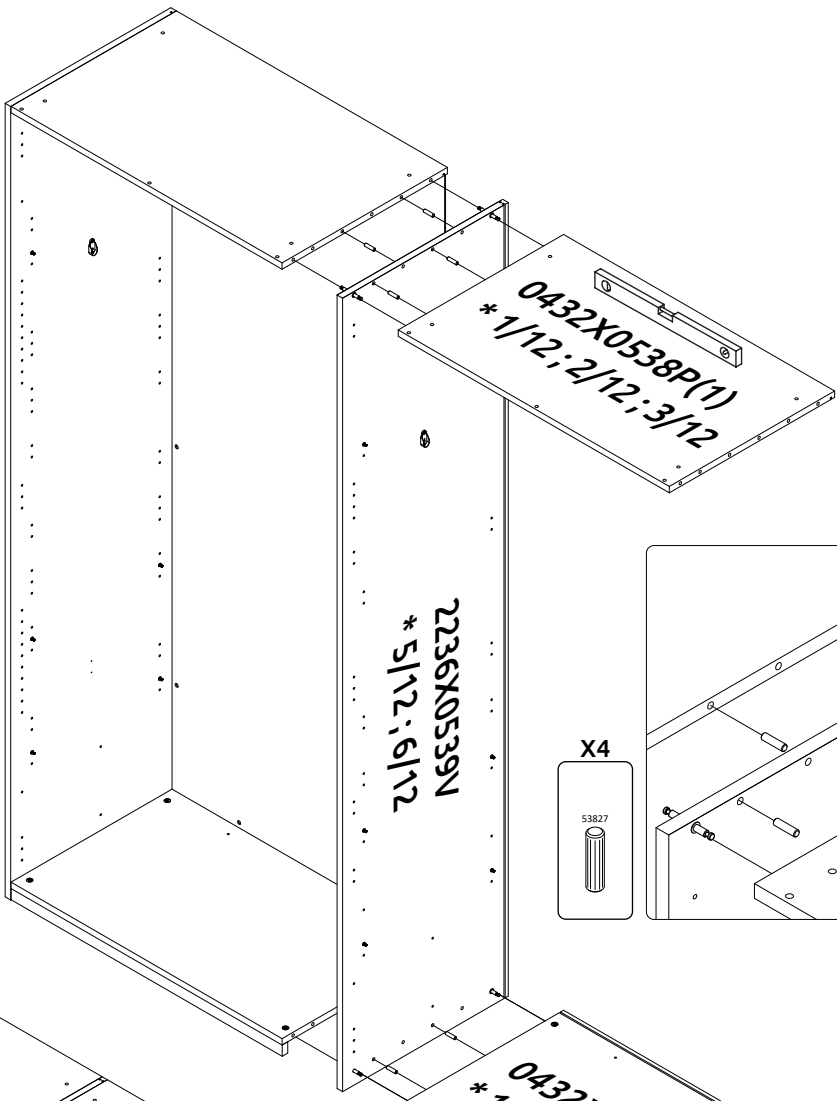

21

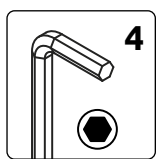
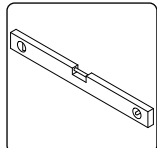
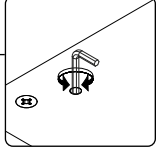
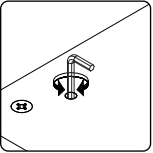
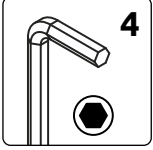
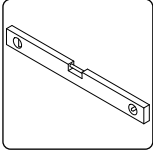

22

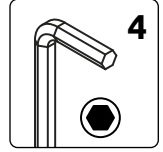
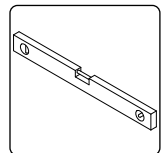
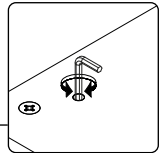
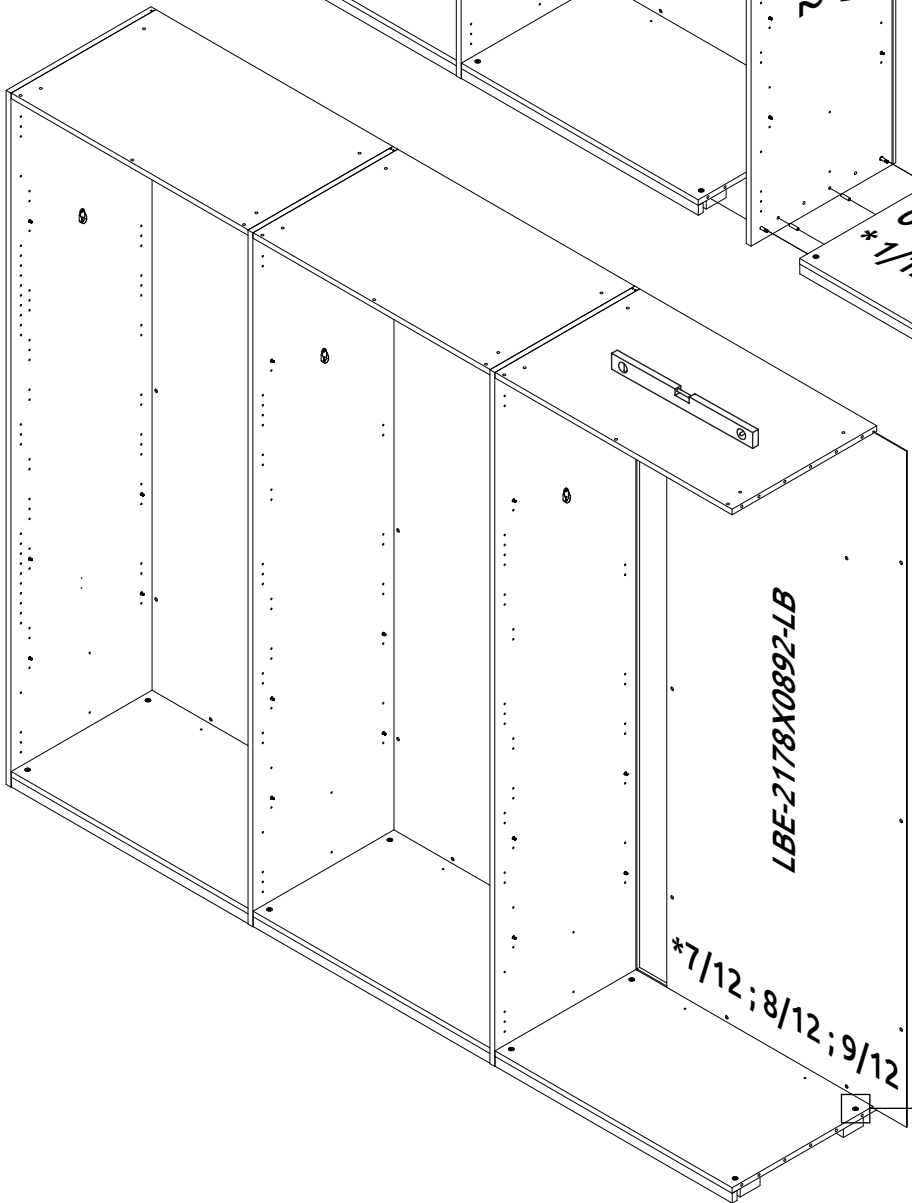
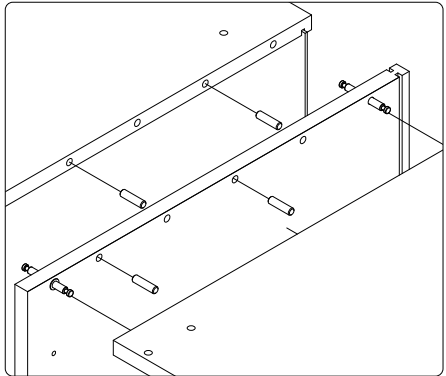
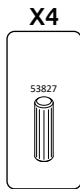
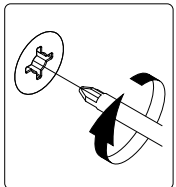
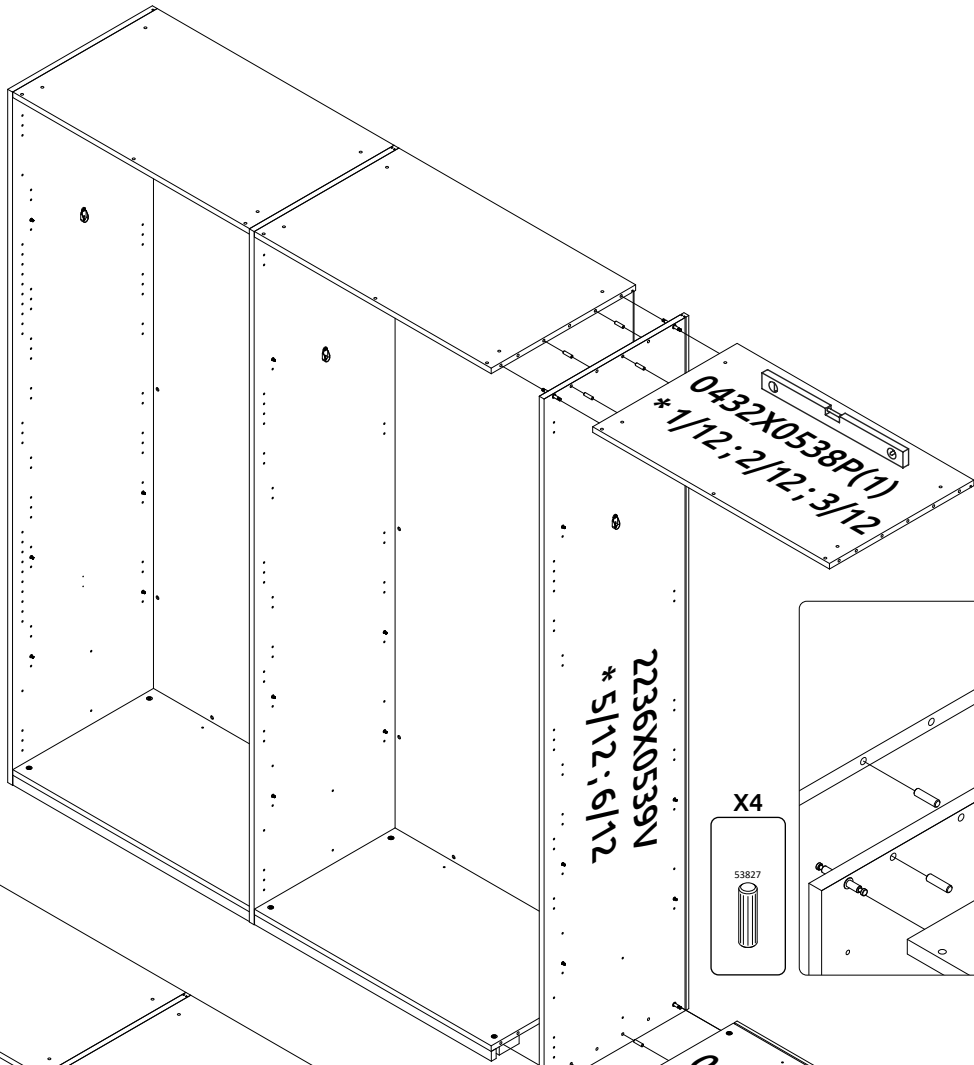
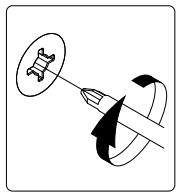

23

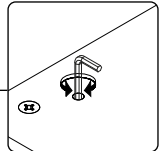
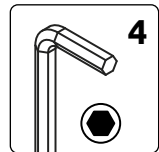
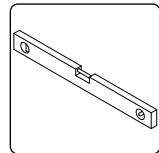

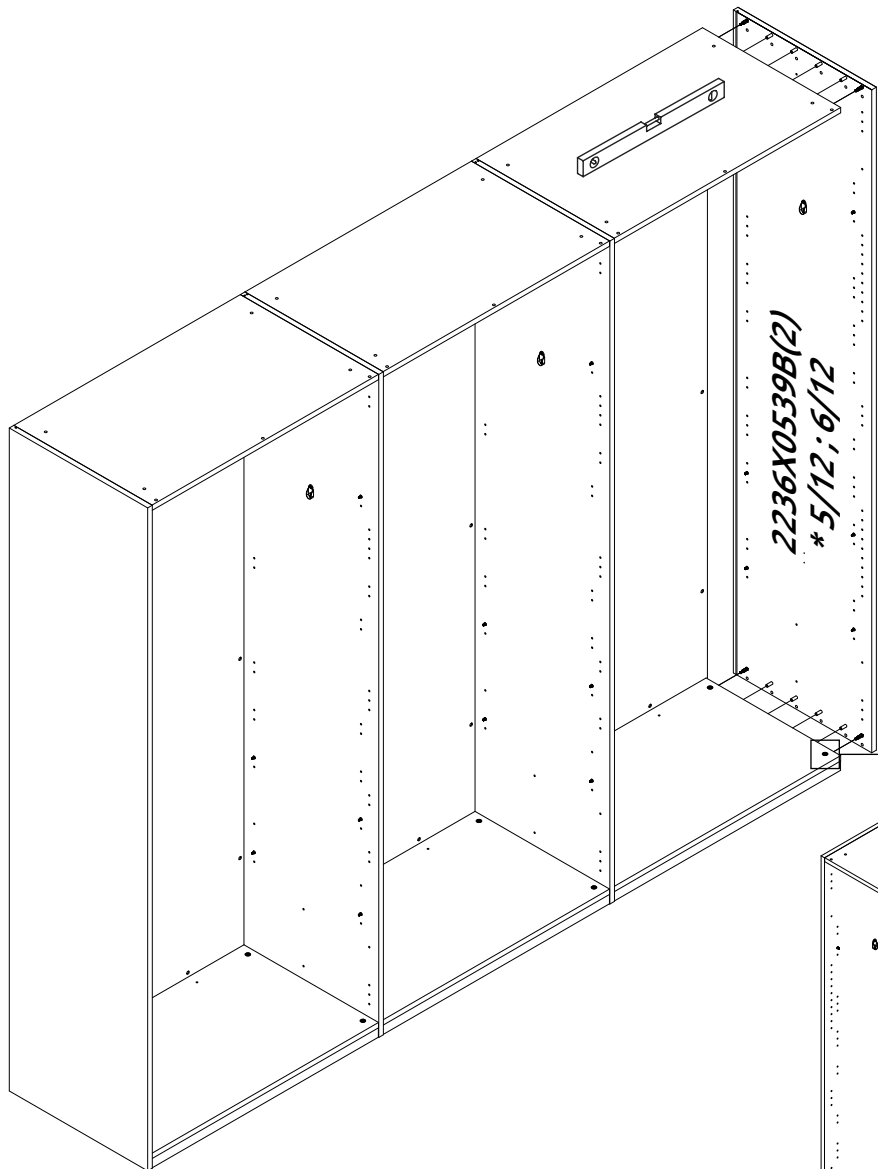

**24**

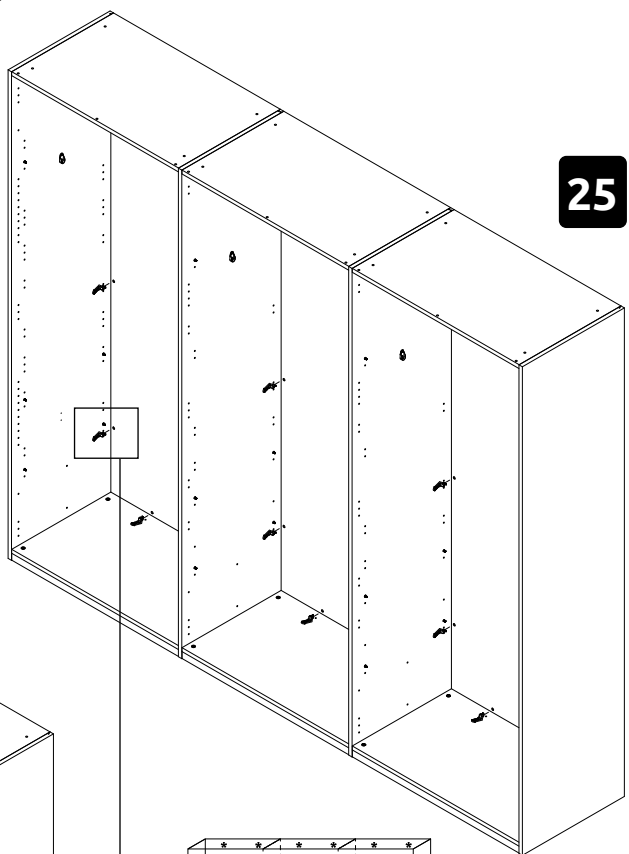
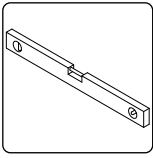
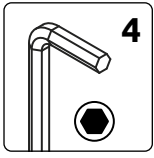
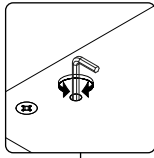
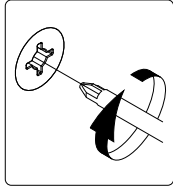

**25**

**26**

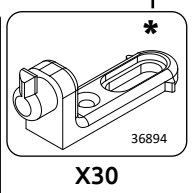
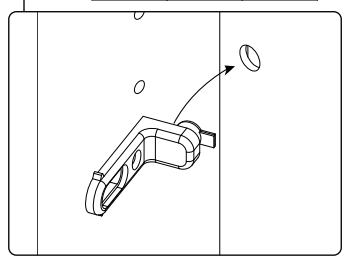
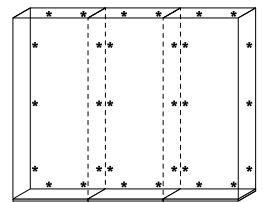
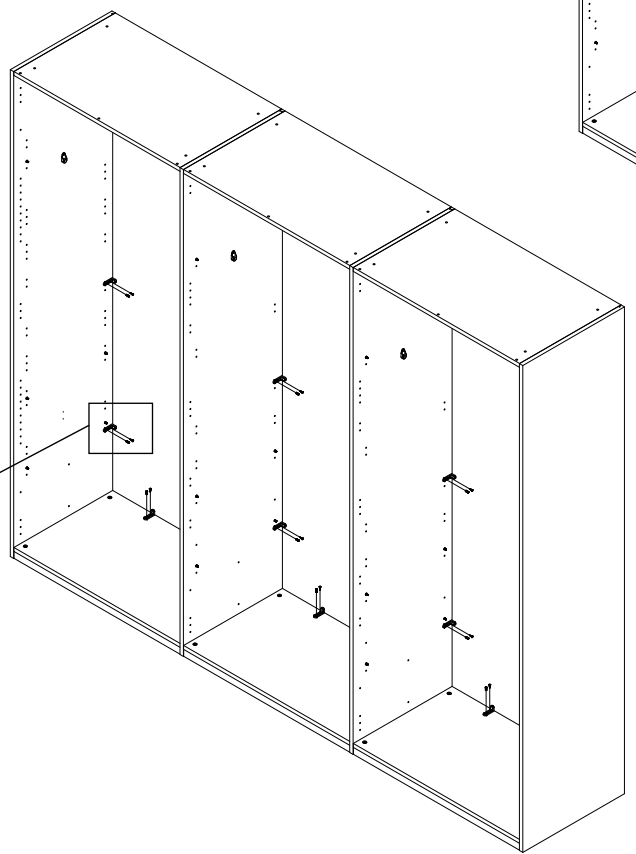
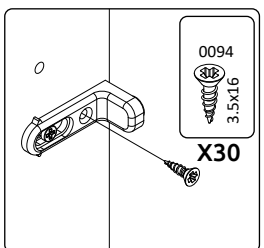
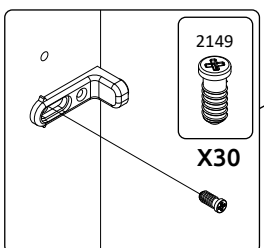
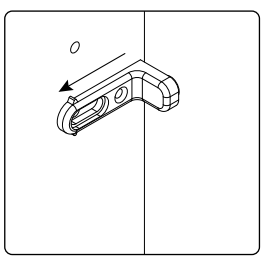

27

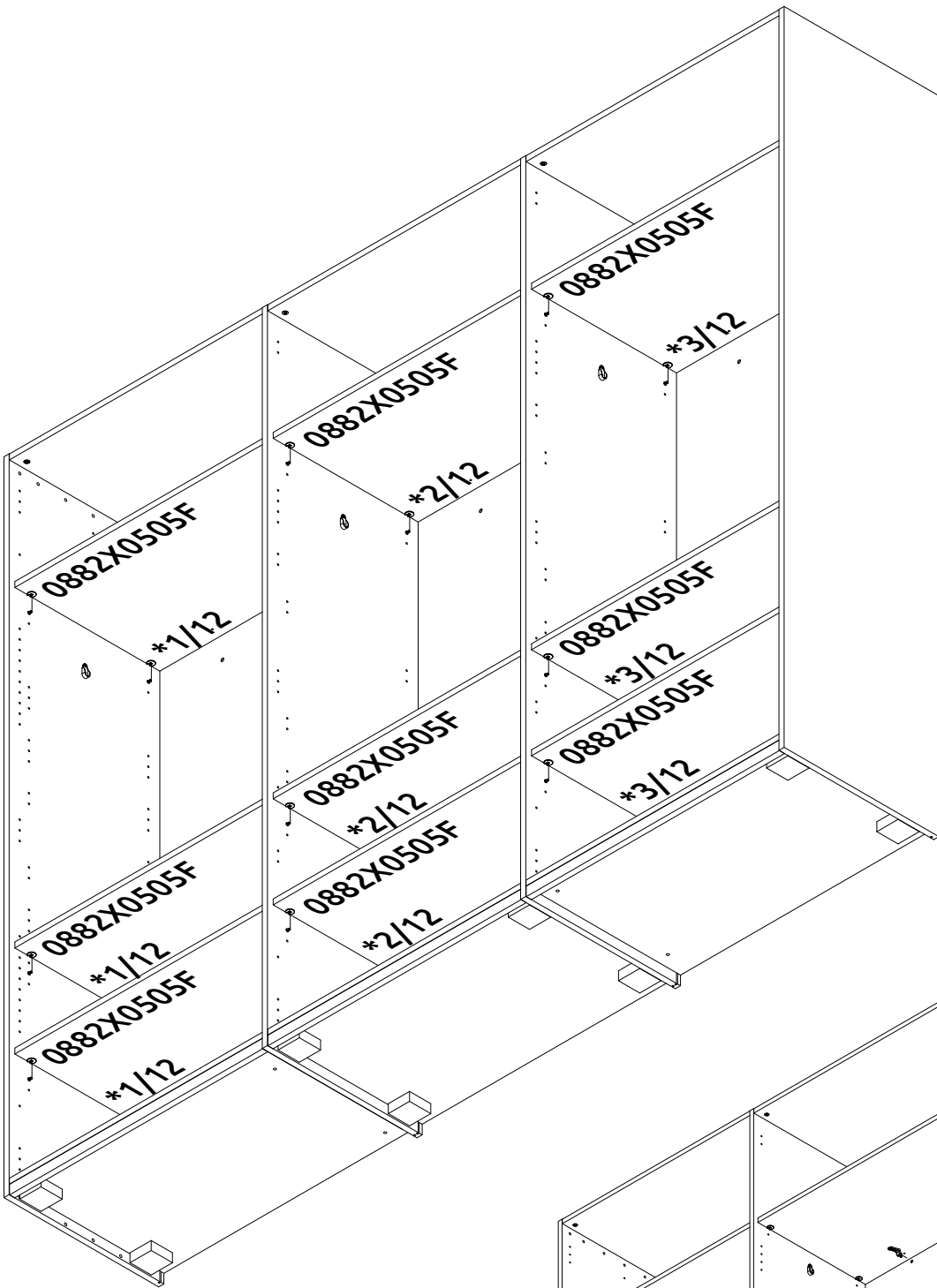

28

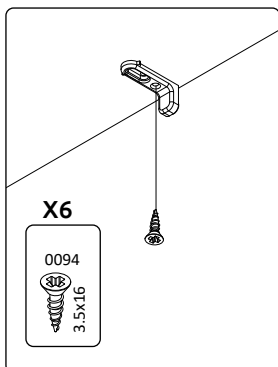
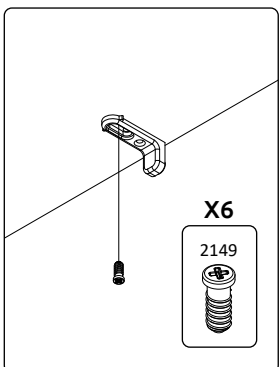
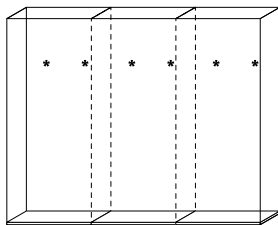
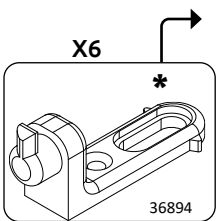
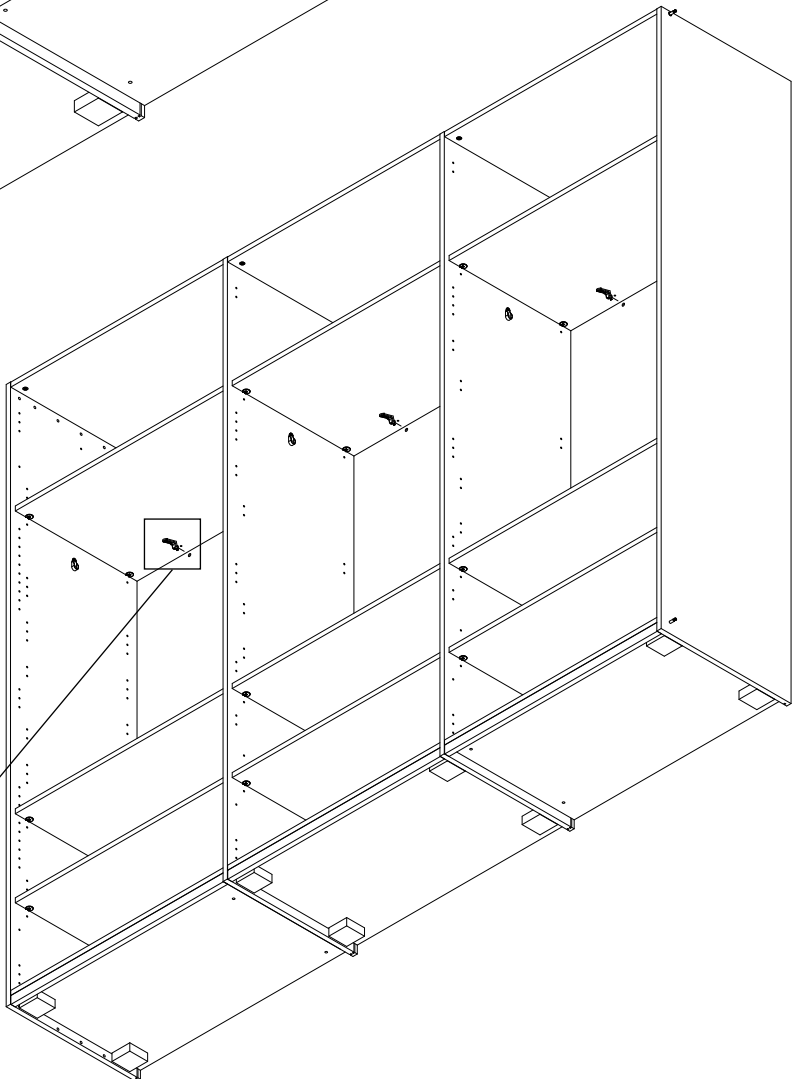

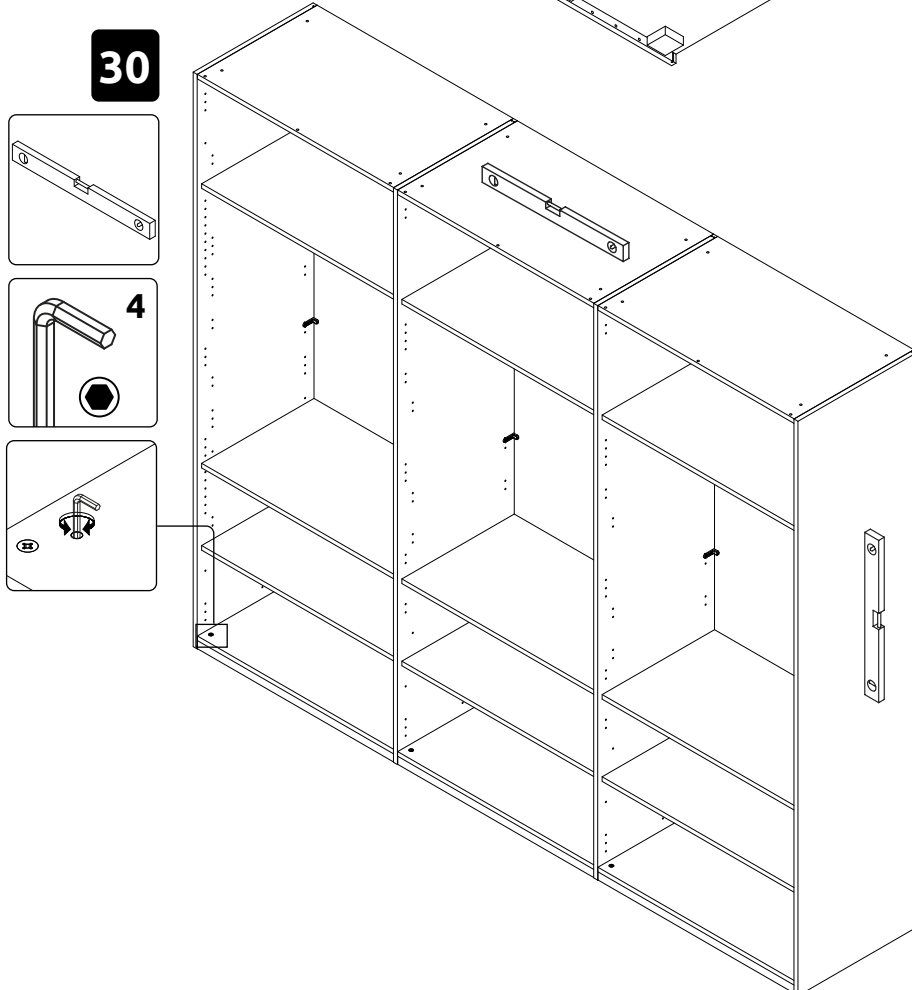
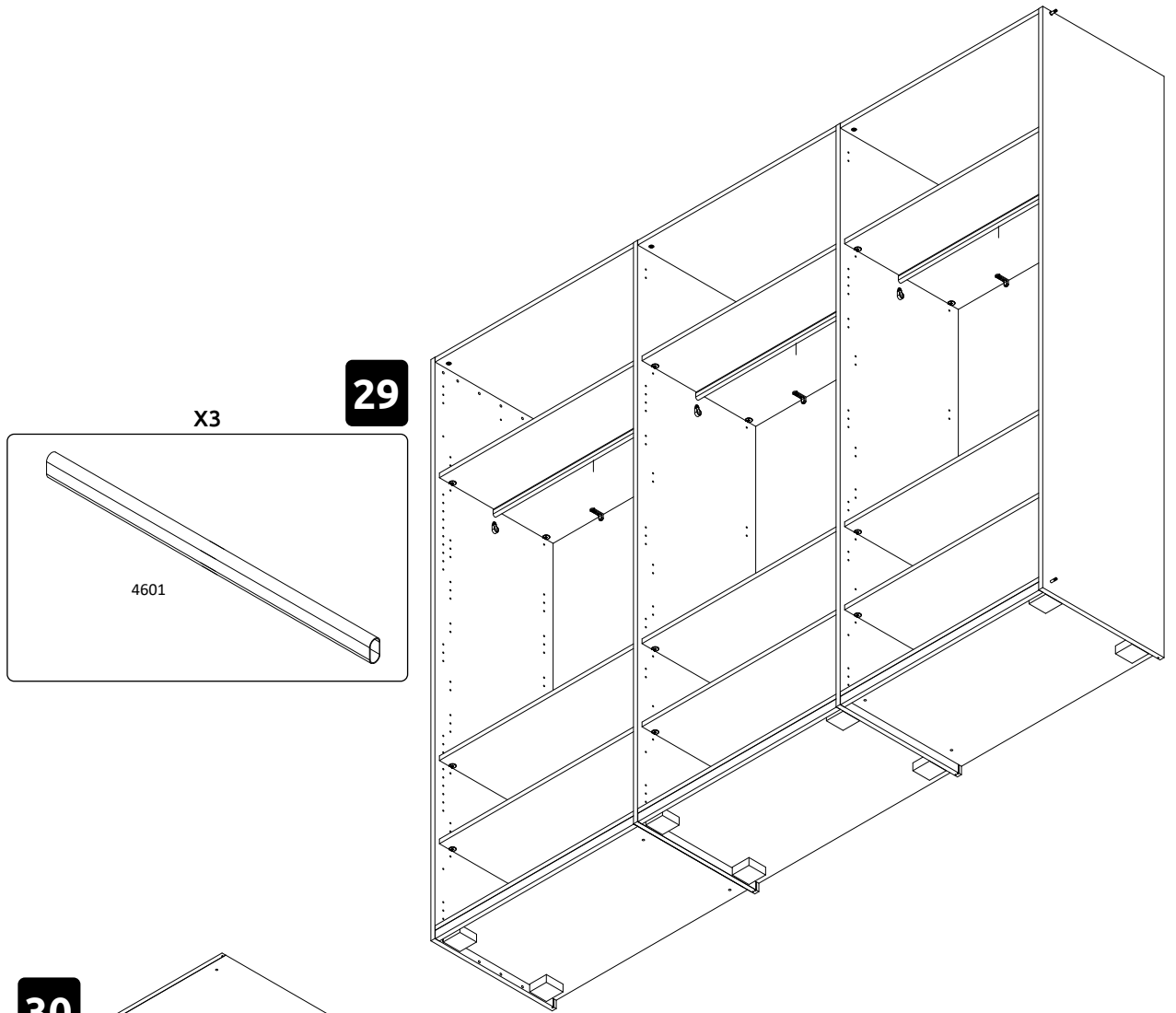

**31**

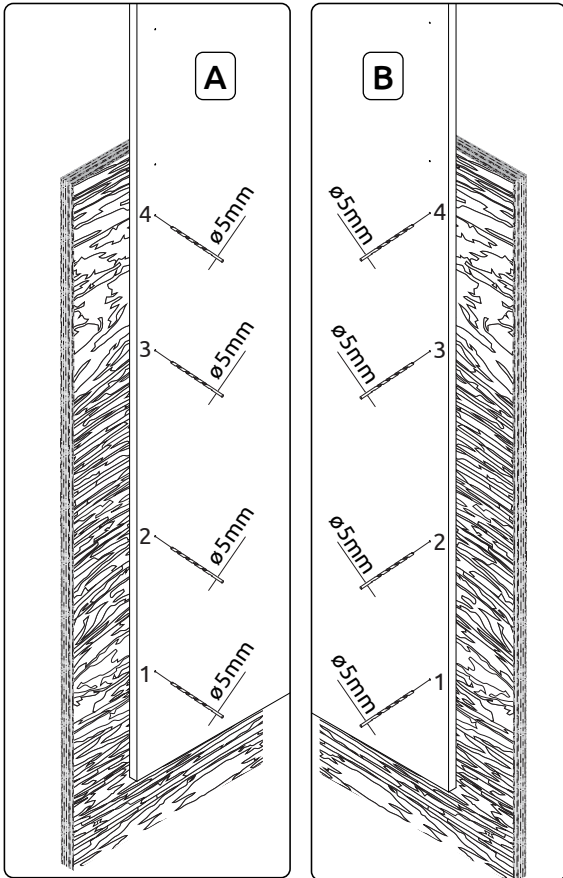

**A**

**B**

- 2200X0447K(1)    2200X0447K(2)
- 2200X0447K(3)    2200X0447K(4)
- 2200X0447K(5)    2200X0447K(6)

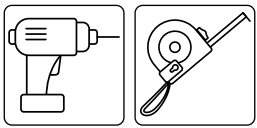

\* opt P6/PN

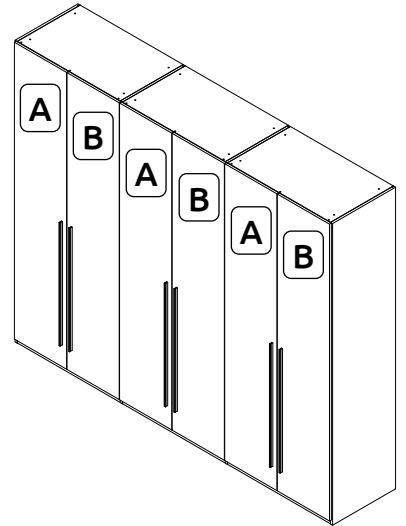

**32**

\* opt P6/PN

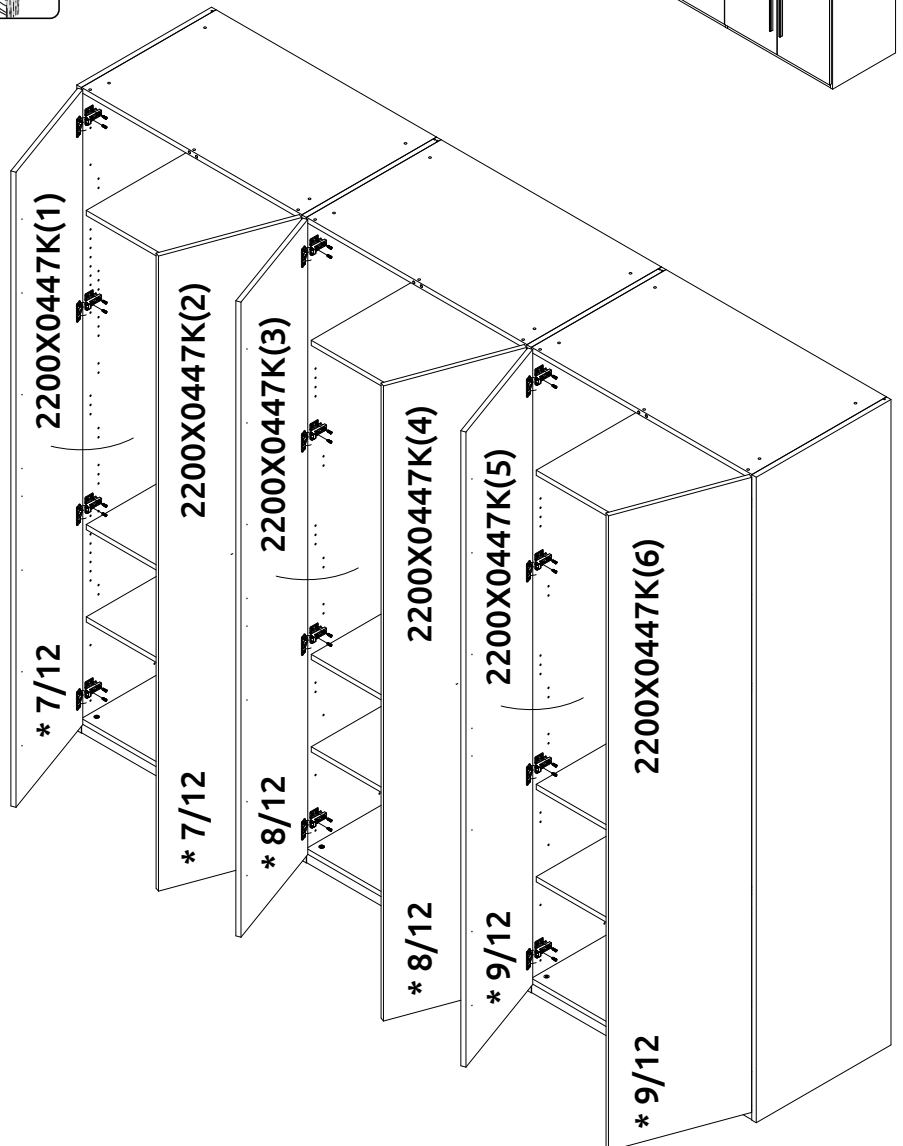
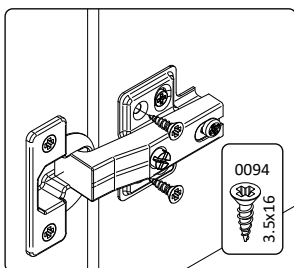
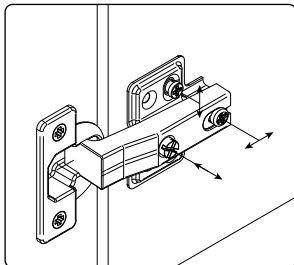
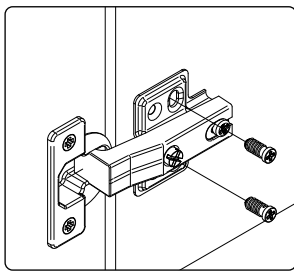

**33**

\* opt P6/PN

**X6**

6319

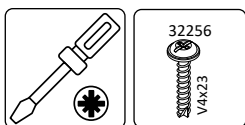
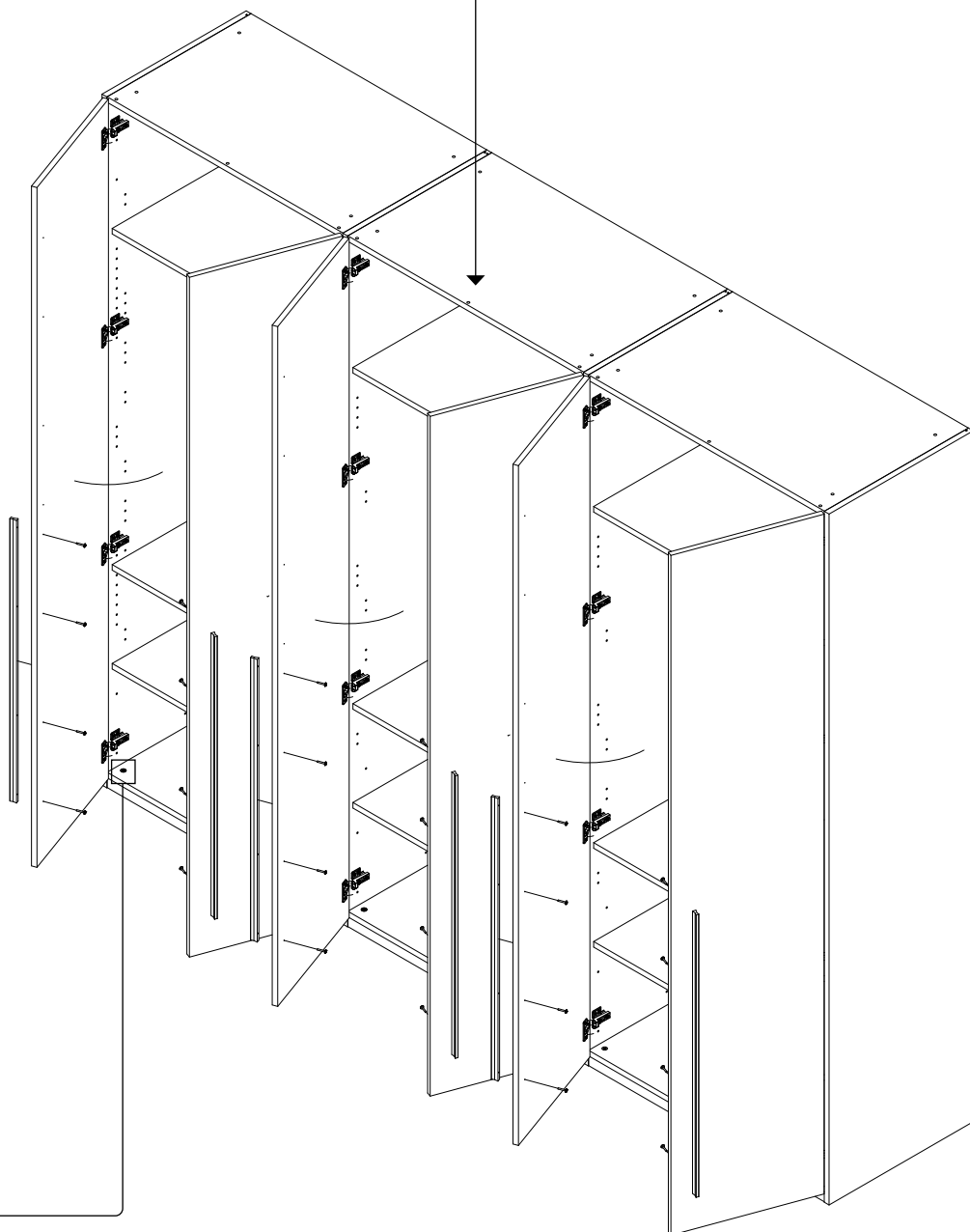
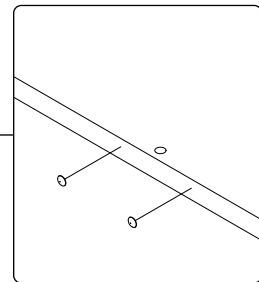

32256

V4x23

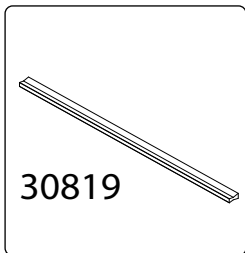

30819

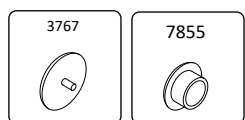
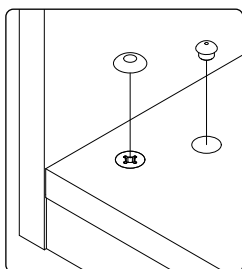

3767

7855

X12

X8

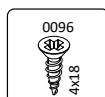
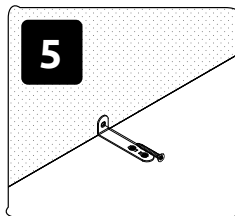
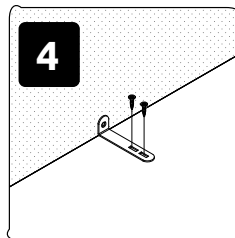
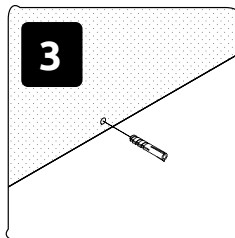
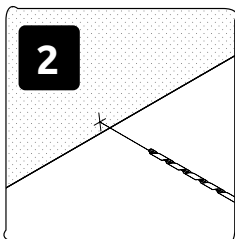
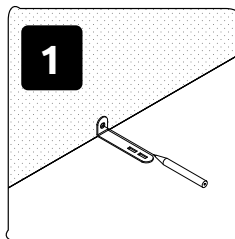
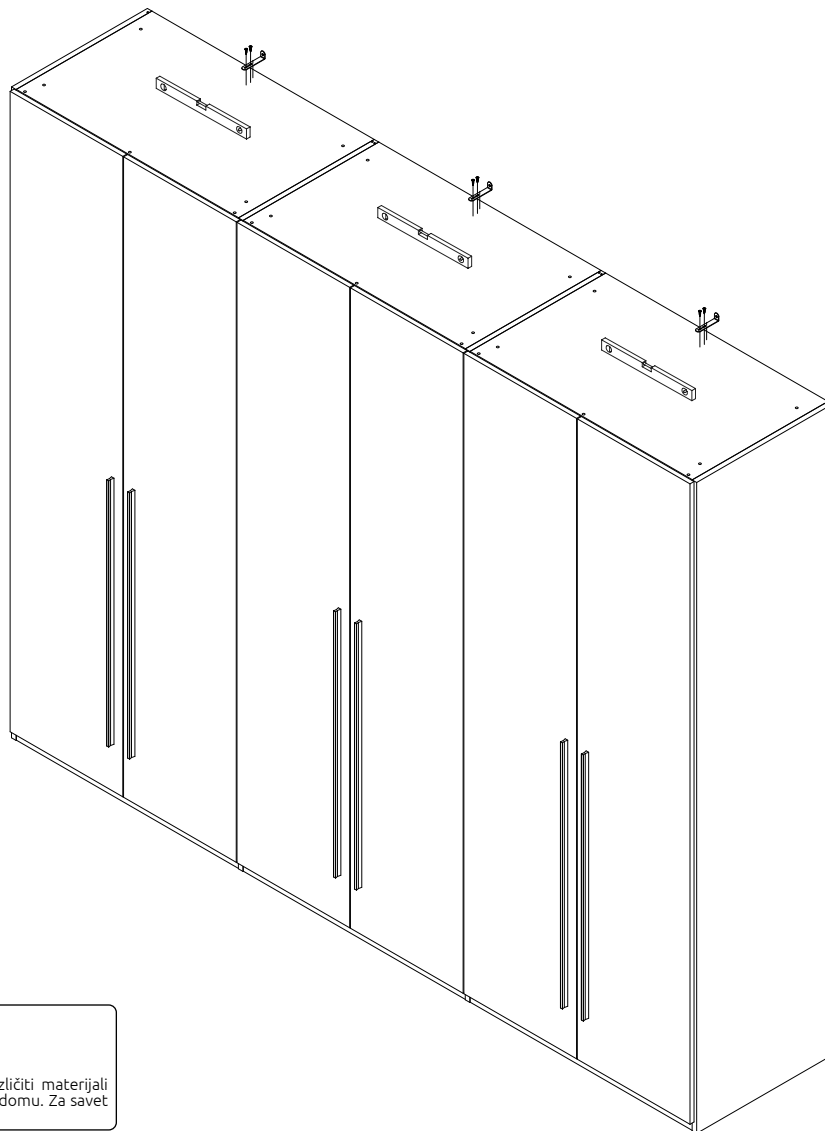
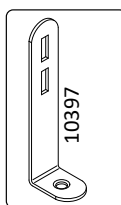
**34****\* opt P6/PN****X6****X3****SRPSKI**

Bitno! Pažljivo pročitajte! Sačuvajte za ubuduće.

**UPOZORENJE!**

Nisu dati okovi, tiplovi i šrafovi za pričvršćivanje jer se zidovi razlikuju i različiti materijali zahtevaju i različite okove. Upotrebite one koji su pogodni za zidove u vašem domu. Za savet koje okove da upotrebite, obratite se u lokalnoj gvozdari.

**ENGLISH**

Important information! Read carefully! Keep this information for further reference.

**WARNING!**

Fixing devices for the wall are not included since different wall materials require different types of fixing devices. Use fixing devices suitable for the walls in your home. For advice on suitable fixing systems, contact your local specialized dealer.

**DEUTSCH**

Wichtige Information! Bitte sorgfältig lesen und aufbewahren!

**ACHTUNG HINWEIS!**

Beschläge für die Wandbefestigung sind nicht beigegeben, da sie von der jeweiligen Wandbeschaffenheit abhängig sind. Benutzen Sie ausschließlich Befestigungsbeschläge, die für die heimischen Wände geeignet sind. Bei diesbezüglichen Fragen ziehen Sie den örtlichen Fachhandel zu Rate.

**РУССКИЙ**

Важная информация! Внимательно прочитайте! Сохраните эту информацию.

**ВНИМАНИЕ**

Крепежные средства для крепления к стене не прилагаются, для разных материалов стен требуются различные крепления. Используйте крепежные средства, подходящие для материала стен в Вашем доме. Если Вы не уверены, какой тип крепления подходит к данному материалу, обратитесь в специализированный магазин.

**FRENCH**

Important! Lire attentivement! Économisez pour l'avenir.

**AVERTISSEMENT!**

La quincaillerie, les chevilles et les vis ne sont pas fournis pour la fixation au mur, car les murs sont différents et nécessitent une quincaillerie différente. Utilisez ceux qui conviennent aux murs de votre maison. Pour obtenir des conseils sur le matériel à utiliser, contactez votre quincaillerie locale.

**ITALIAN**

Importante! Leggi attentamente! Risparmia per il futuro.

**AVVERTIMENTO!**

Non vengono forniti ferramenta, tasselli e viti per il fissaggio al muro, in quanto le pareti sono diverse e richiedono ferramenta diversa. Usa quelli adatti alle pareti della tua casa. Per consigli su quale hardware utilizzare, contattare il negozio di ferramenta locale.

**SLOVAKIAN**

Dôležit! Čítaj pozorne! Uložíť do budúcnosti.

**VAROVÁNIE!**

Kovány, hmoždinky a skrutky sa nedodávajú na pripevnenie na stenu, pretože steny sú rôzne a vyžadujú si iný hardvér. Použite tie, ktoré sú vhodné na steny vo vašej domácnosti. Ak potrebujete radu, aký hardvér použiť, obráťte sa na miestne železiarstvo.

**CZECH**

Důležité! Čtěte pozorně! Ušetřete na budoucnost.

**VAROVÁNÍ!**

Kovány, hmoždinky a šrouby nejsou součástí dodávky pro upevnění na stěnu, protože stěny jsou různé a vyžadují jiný hardware. Použijte ty, které se hodí na stěny ve vaší domácnosti. Chcete-li poradit, jaký hardware použít, kontaktujte místní železářství.

**HUNGARIAN**

Fontos! Olvasd figyelmesen! Mentse a jövőre.

**FIGYELMEZTETÉS!**

A falra rögzítéshez nem tartozék a vasalat, a tiplik és a csavar, mivel a falak különbözőek, és más-más hardvert igényelnek. Használja azokat, amelyek alkalmasak otthona falaira. A megfelelő hardver használatára vonatkozó tanácsért forduljon a helyi hardverbolthoz.

**NETHERLAND**

Belangrijk! Lees aandachtig! Sparen voor de toekomst.

**WAARSCHUWING!**

Er zijn geen bevestigingsmiddelen, pluggen en schroeven meegeleverd voor bevestiging aan de muur, omdat de muren verschillend zijn en ander bevestigingsmateriaal vereisen. Gebruik degene die geschikt zijn voor de muren in uw huis. Neem voor advies over welke hardware u moet gebruiken contact op met uw plaatselijke ijzerhandel.

**TURKISH**

Önemli! Dikkatlice oku! Gelecek için tasarruf edin.

**UYARI!**

Duvarlar farklı olduğundan ve farklı donanım gerektirdiğinden duvara sabitlemek için donanım, dübel ve vidalar sağlanmamaktadır. Evinizin duvarlarına uygun olanları kullanın. Hangi donanım kullanılacağına ilişkin tavsiye için yerel donanım mağazanıza başvurun.

**ROMANIAN**

Important! Citește cu atenție! Salvează pentru viitor.

**AVERTIZARE!**

Feroneria, diblurile și șuruburile nu sunt prevăzute pentru fixarea pe perete, deoarece pereții sunt diferiți și necesită feronerie diferită. Folosește-le pe cele potrivite pentru pereții casei tale. Pentru sfaturi despre hardware-ul de utilizat, contactați magazinul local de hardware.

**POLSKI**

Ważne! Uważnie przeczytać! Zachować do wykorzystania w przyszłości.

**OSTRZEŻENIE!**

Elementy do mocowania w ścianie: kotwy i wkręty do nich, nie zostały dostarczone w opakowaniu ponieważ ściany są wykonane z różnych materiałów, które wymagają różnych elementów montażowych. Prosimy zakupić i zastosować te, które są odpowiednie do ścian w Państwa mieszkaniu. Aby uzyskać poradę, jakie elementy mocujące zastosować, należy skontaktować się ze sprzedawcami w wyspecjalizowanym sklepie.





37

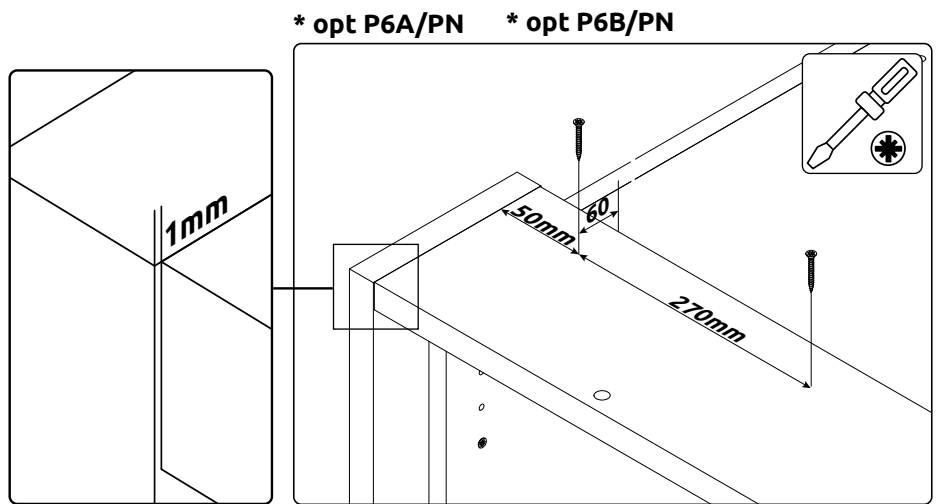
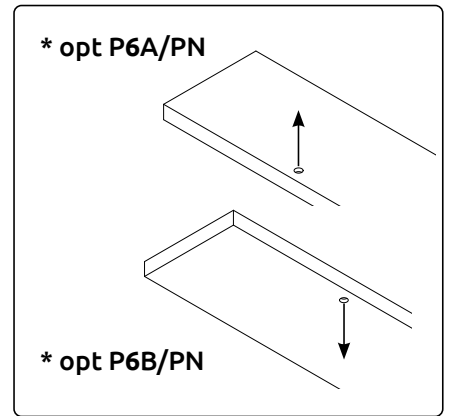
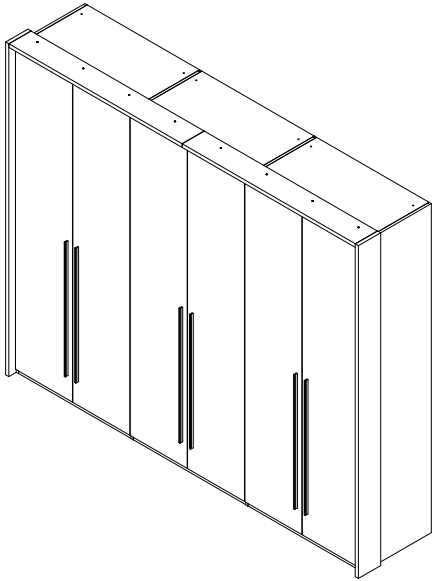

\* opt P6B/PN

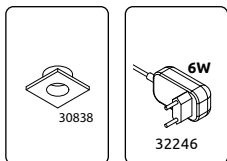

X6

X1

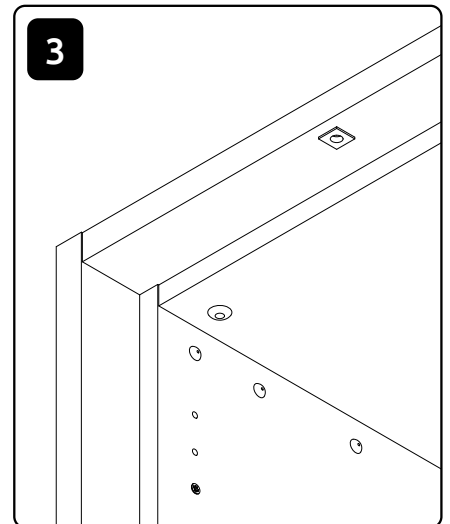
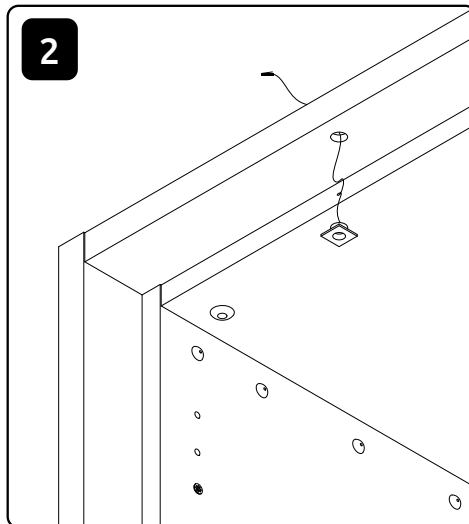
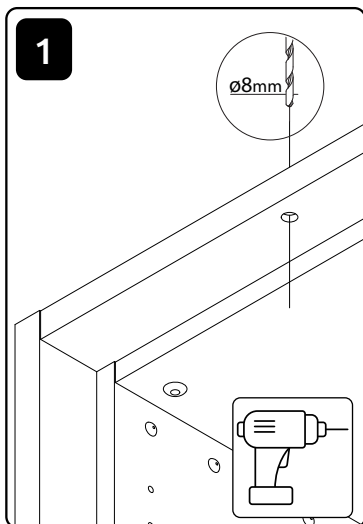

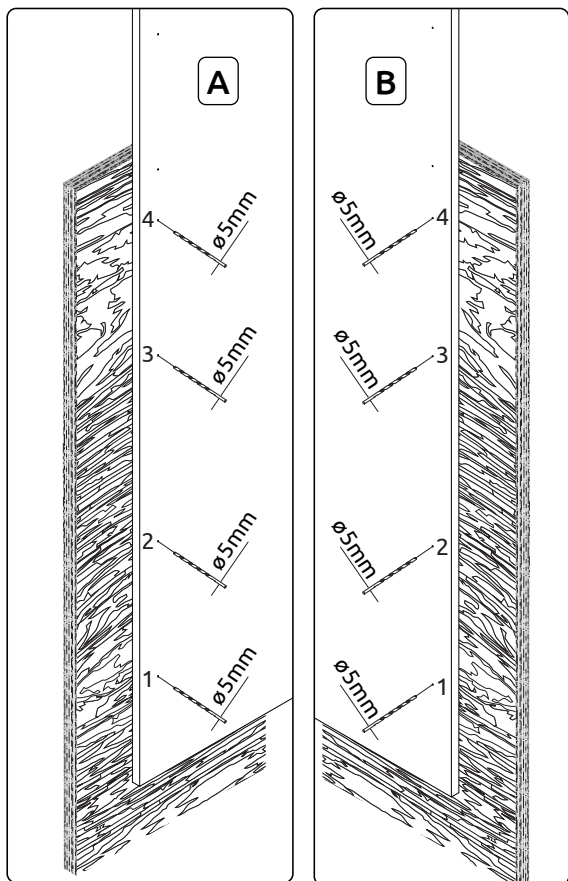

**38**

\* opt P6A/PN  
\* opt P6B/PN

**A**

**B**

- 2200X0447K(1)    2200X0447K(2)
- 2200X0447K(3)    2200X0447K(4)
- 2200X0447K(5)    2200X0447K(6)

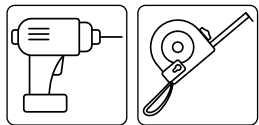
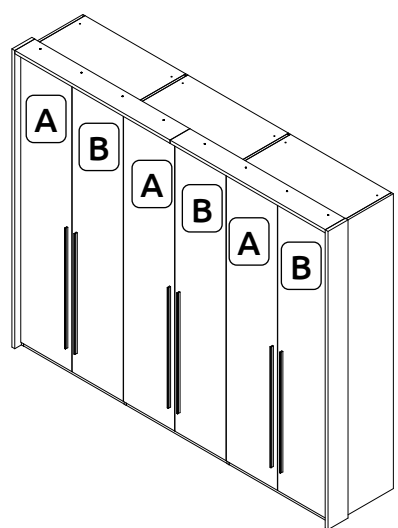

**39**

\* opt P6A/PN  
\* opt P6B/PN

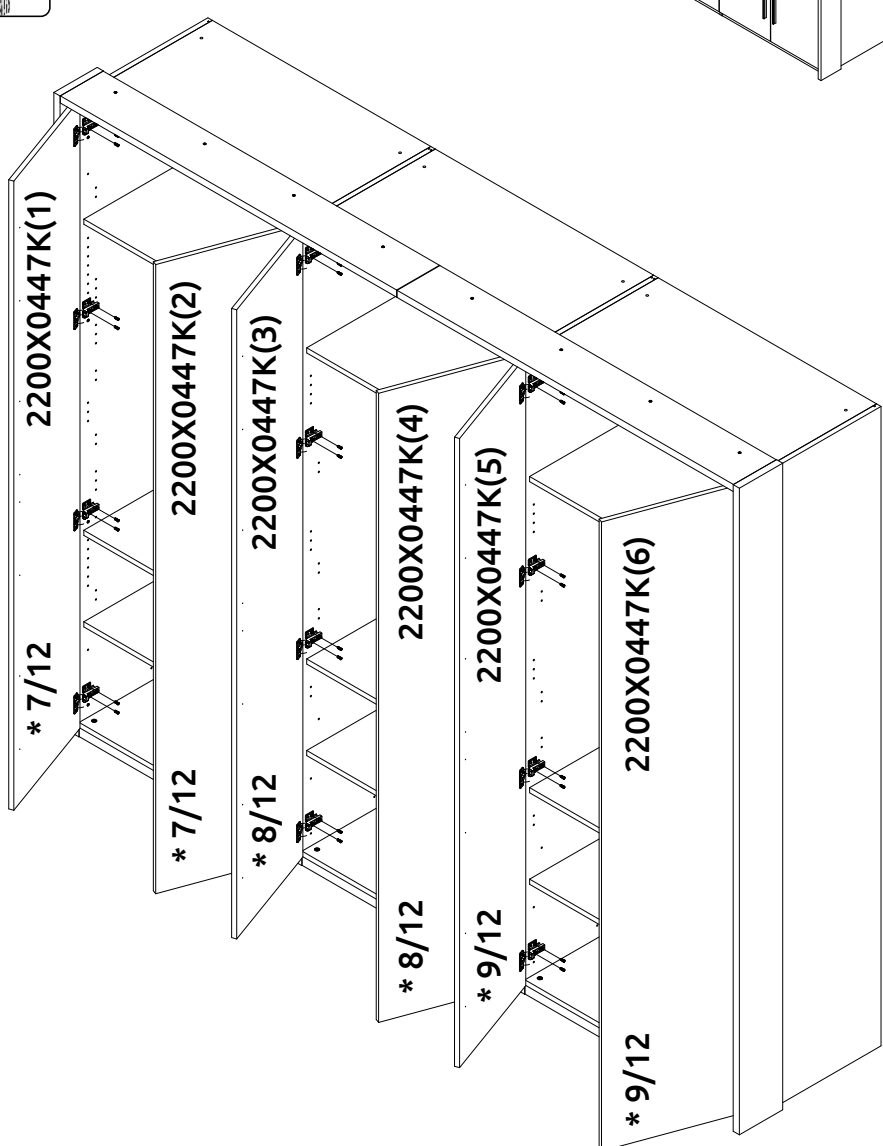
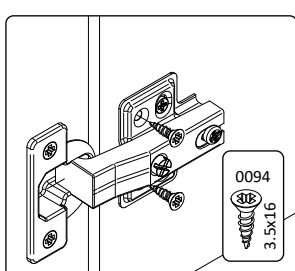
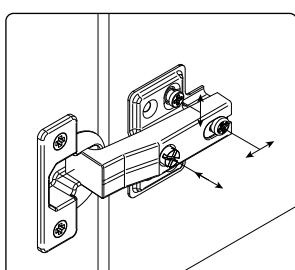
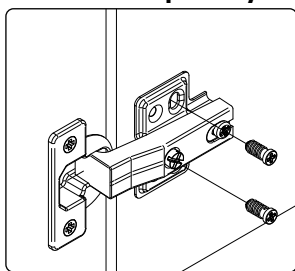

**40**

\* opt P6A/PN  
\* opt P6B/PN

**X6**

6319

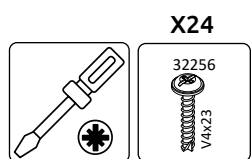
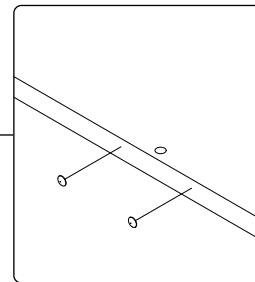

**X24**

32256  
V4x23

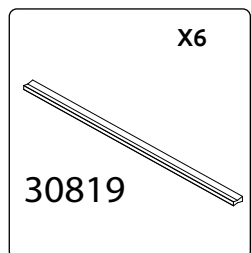

**X6**

30819

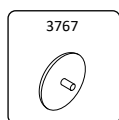
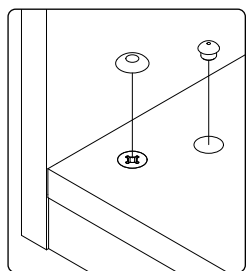

**X12**



7855

**X8**

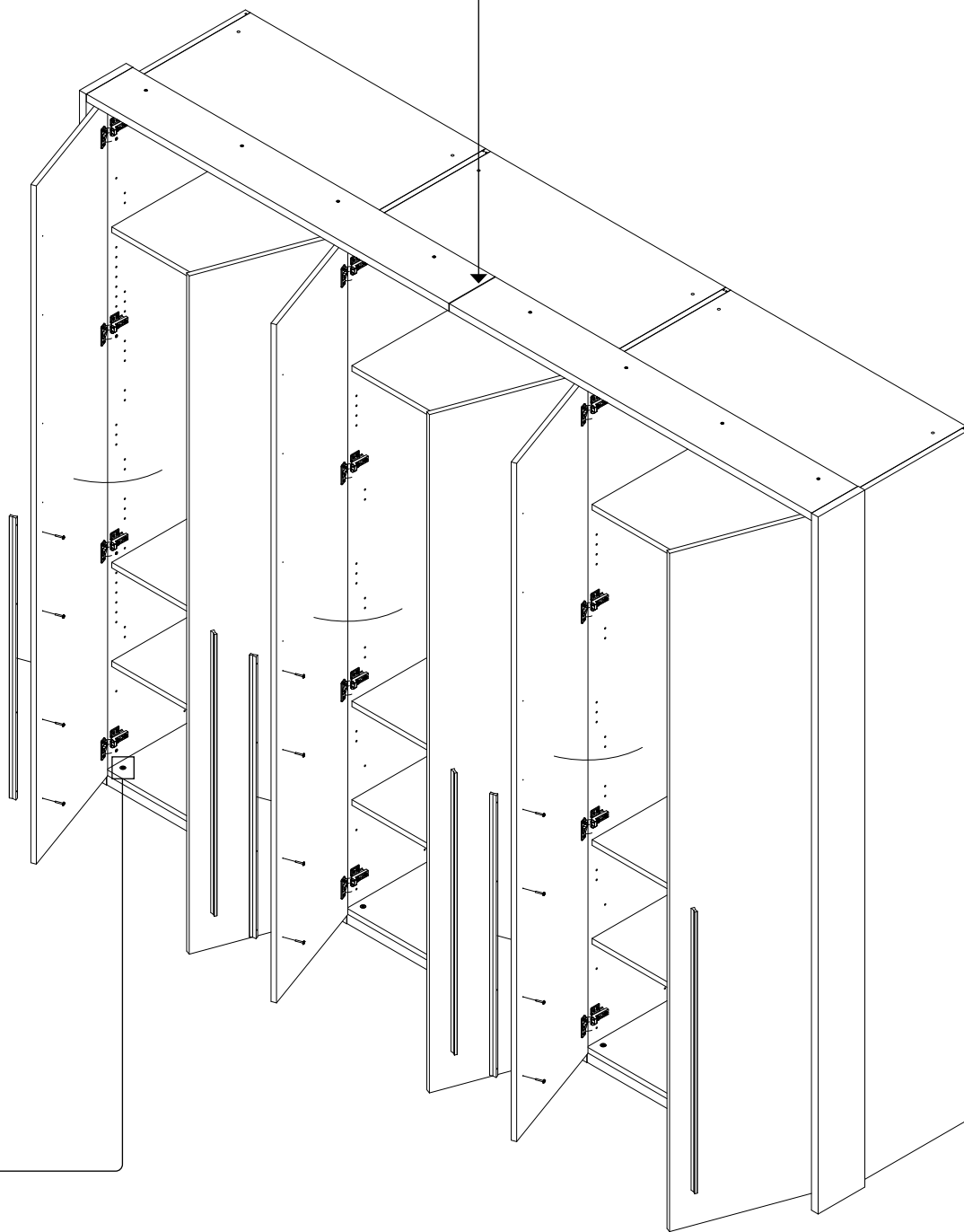

**41**

\* opt P6A/PN  
\* opt P6B/PN

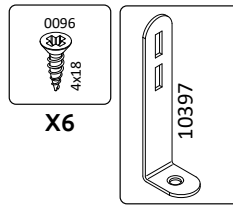
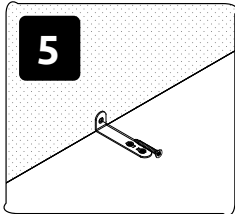
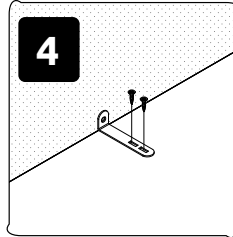
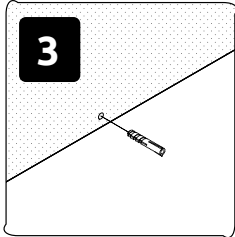
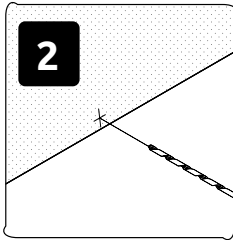
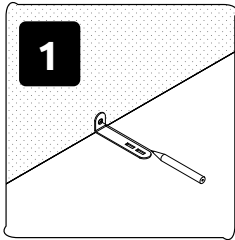
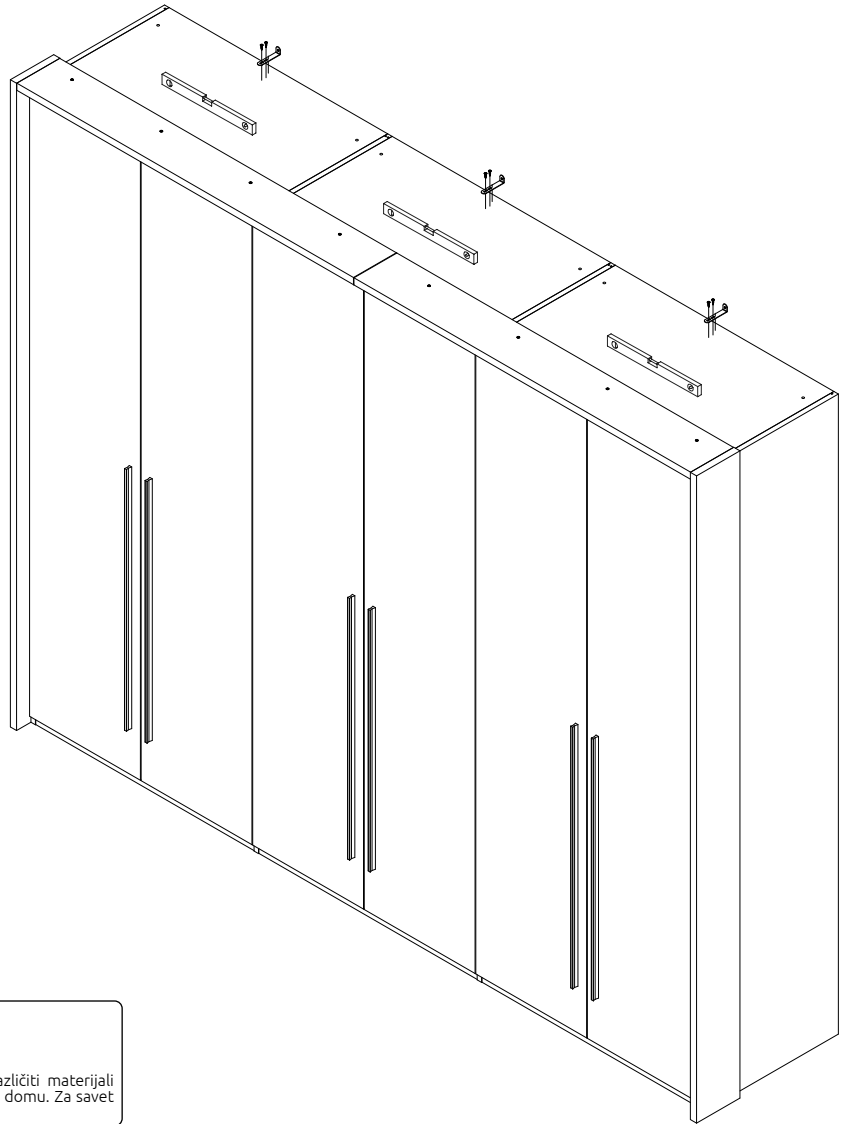
**X6****10397****X3****SRPSKI**

Bitno! Pažljivo pročitajte! Sačuvajte za ubuduće.

**UPOZORENJE!**

Nisu dati okovi, tiplovi i šrafovi za pričvršćivanje jer se zidovi razlikuju i različiti materijali zahtevaju i različite okove. Upotrebite one koji su pogodni za zidove u vašem domu. Za savet koje okove da upotrebite, obratite se u lokalnoj gvozdari.

**ENGLISH**

Important information! Read carefully! Keep this information for further reference.

**WARNING!**

Fixing devices for the wall are not included since different wall materials require different types of fixing devices. Use fixing devices suitable for the walls in your home. For advice on suitable fixing systems, contact your local specialized dealer.

**DEUTSCH**

Wichtige Information! Bitte sorgfältig lesen und aufbewahren!

**ACHTUNG HINWEIS!**

Beschläge für die Wandbefestigung sind nicht beige-packt, da sie von der jeweiligen Wandbeschaffenheit abhängig sind. Benutzen Sie ausschließlich Befestigungsbeschläge, die für die heimischen Wände geeignet sind. Bei diesbezüglichen Fragen ziehen Sie den örtlichen Fachhandel zu Rate.

**РУССКИЙ**

Важная информация! Внимательно прочитайте! Сохраните эту информацию.

**ВНИМАНИЕ**

Крепежные средства для крепления к стене не прилагаются, для разных материалов стен требуются различные крепления. Используйте крепежные средства, подходящие для материала стен в Вашем доме. Если Вы не уверены, какой тип креплений подходит к данному материалу, обратитесь в специализированный магазин.

**FRENCH**

Important! Lire attentivement! Économisez pour l'avenir.

**AVERTISSEMENT!**

La quincaillerie, les chevilles et les vis ne sont pas fournis pour la fixation au mur, car les murs sont différents et nécessitent une quincaillerie différente. Utilisez ceux qui conviennent aux murs de votre maison. Pour obtenir des conseils sur le matériel à utiliser, contactez votre quincaillerie locale.

**ITALIAN**

Importante! Leggi attentamente! Risparmia per il futuro.

**AVVERTIMENTO!**

Non vengono forniti ferramenta, tasselli e viti per il fissaggio al muro, in quanto le pareti sono diverse e richiedono ferramenta diversa. Usa quelli adatti alle pareti della tua casa. Per consigli su quale hardware utilizzare, contattare il negozio di ferramenta locale.

**SLOVAKIAN**

Dôležitá! Čítaj pozorne! Ulož si do budúcnosti.

**VAROVÁNIE!**

Kovanie, hmoždinky a skrutky sa nedodávajú na prípevnenie na stenu, pretože steny sú rôzne a vyžadujú si iný hardvér. Použite tie, ktoré sú vhodné na steny vo vašej domácnosti. Ak potrebujete radu, aký hardvér použiť, obráťte sa na miestne železiarstvo.

**CZECH**

Důležité! Čtěte pozorně! Ušetřete na budoucnost.

**VAROVÁNÍ**

Kování, hmoždinky a šrouby nejsou součástí dodávky pro upevnění na stěnu, protože stěny jsou různé a vyžadují jiný hardware. Použijte ty, které se hodí na stěny ve vaší domácnosti. Chcete-li poradit, jaký hardware použít, kontaktujte místní železářství.

**HUNGARIAN**

Fontos! Olvasd figyelmesen! Mentse a jövőre.

**FIGYELMEZTETÉS!**

A falra rögzítéshez nem tartozék a vasalat, a tiplik és a csavar, mivel a falak különbözőek, és más-más hardvert igényelnek. Használja azokat, amelyek alkalmasak otthona falaira. A megfelelő hardver használatára vonatkozó tanácsért forduljon a helyi hardverbolthoz.

**NETHERLAND**

Belangrijk! Lees aandachtig! Sparen voor de toekomst.

**WAARSCHUWING!**

Er zijn geen bevestigingsmiddelen, pluggen en schroeven meegeleverd voor bevestiging aan de muur, omdat de muren verschillend zijn en ander bevestigingsmateriaal vereisen. Gebruik degene die geschikt zijn voor de muren in uw huis. Neem voor advies over welke hardware u moet gebruiken contact op met uw plaatselijke ijzerhandel.

**TURKISH**

Önemli! Dikkatlice oku! Gelecek için tasarruf edin.

**UYARI!**

Duvarlar farklı olduğundan ve farklı donanım gerektirdiğinden duvara sabitlemek için donanım, dübel ve vidalar sağlanmamaktadır. Evinizin duvarlarına uygun olanları kullanın. Hangi donanımın kullanılacağına ilişkin tavsiye için yerel donanım mağazanıza başvurun.

**ROMANIAN**

Important! Citește cu atenție! Salvează pentru viitor.

**AVERTIZARE!**

Feroneria, diblurile și șuruburile nu sunt prevăzute pentru fixarea pe perete, deoarece pereții sunt diferiți și necesită feronerie diferită. Folosește-le pe cele potrivite pentru pereții casei tale. Pentru sfaturi despre hardware-ul de utilizat, contactați magazinul local de hardware.

**POLSKI**

Ważne! Uważnie przeczytać! Zachować do wykorzystania w przyszłości.

**OSTRZEŻENIE!**

Elementy do mocowania w ścianie: kotwy i wkrety do nich, nie zostały dostarczone w opakowaniu ponieważ ściany są wykonane z różnych materiałów, które wymagają różnych elementów montażowych. Prosimy zakupić i zastosować te, które są odpowiednie do ścian w Państwa mieszkaniu. Aby uzyskać poradę, jakie elementy mocujące zastosować, należy skontaktować się ze sprzedawcami w wyspecjalizowanym sklepie.