

SOJAG

QUESTIONS? 49 0 65 71 95 117 0

Assembly Manual / Guide d'assemblage / Manual de ensamblaje / 조립설명서 / Montageanleitung

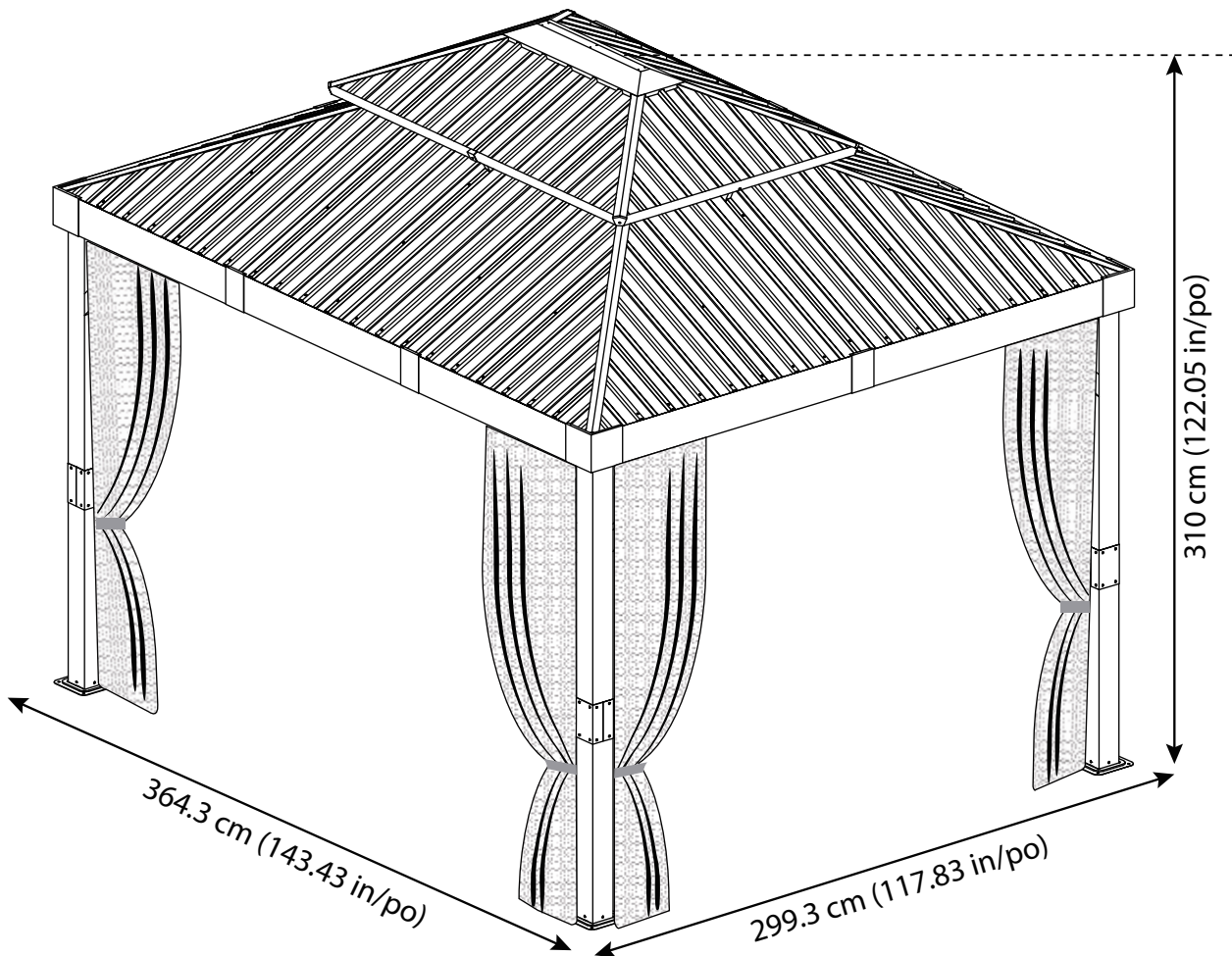

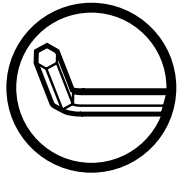

Use the hex keys in the box. / Utilisez les clés hexagonales fournies dans la boîte. / Utilice las llaves hexagonales en la caja. / 상자에 육각 키를 사용 하십시오. / Verwenden Sie die Sechskantschlüssel in der Box.

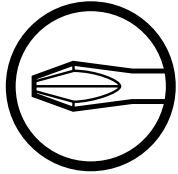

Please use a Phillips screwdriver. / Utilisez un tournevis de type Phillips / Por favor, use un destornillador Phillips. / 십자 드라이버를 사용 하십시오. / Bitte verwenden Sie einen Kreuzschraubenzieher.



You may need to use a drill for this step. / Vous pouvez avoir besoin d'utiliser une perceuse pour cette étape. / Puede que tenga que utilizar un taladro para este paso. / 이 단계에선 드릴을 사용해야 할 수도 있습니다. / Für diesen Schritt können Sie einen Bohrer verwenden.



Wearing protective gloves is recommended. / Le port de gants de protection est recommandé / El uso de guantes de protección se recomienda. / 보호 장갑을 착용 하는 것이 좋습니다. / Das Tragen von Schutzhandschuhen wird empfohlen.



Two or more people are required at this stage. / Deux personnes ou plus sont nécessaires à cette étape. / Dos o más personas se requieren en esta etapa. / 이 단계에서는 두 명 이상 이 필요합니다. / Für diesen Bauschritt sind 2 oder mehr Personen erforderlich.



Do not tighten screws all the way for now. / Ne pas visser fermement pour l'instant. / No atornille con firmeza por ahora. / 아직 나사를 단단히 조이지 마십시오. / Bitte die Schrauben zum jetzigen Zeitpunkt noch nicht fest anziehen.

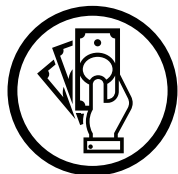

Sold separately. / Vendus séparément. / vendido en las opciones. / 옵션 판매 / Optional erhältlich



Optional step / Étape optionnelle / Paso opcional / 선택적 단계 / Optionaler Schritt

S X12 (+2)

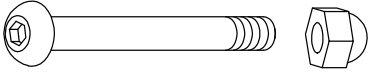

T X64 (+6)

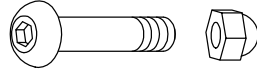

U1 X4 (+1)

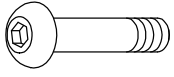

V X339 (+10)

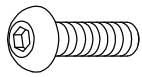

Wa X2



W2 X1

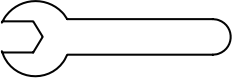

X X32 (+3)

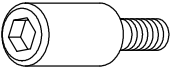

X1 X8 (+2)

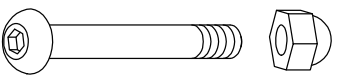

Y X28 (+3)

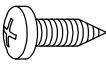

Y1 X8 (+2)

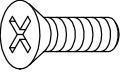

Z X1

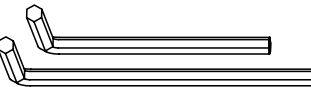

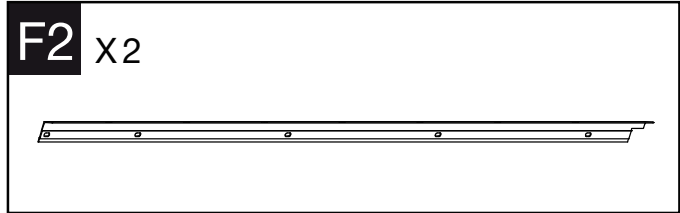
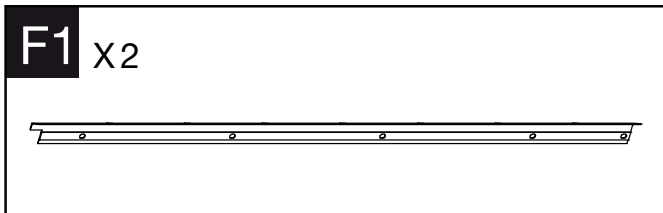
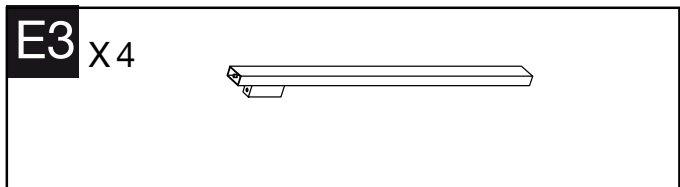
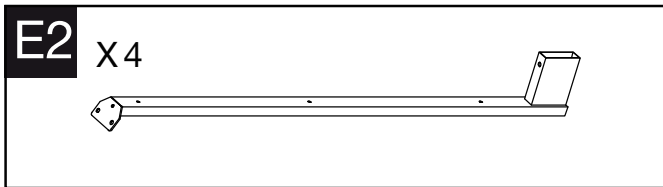
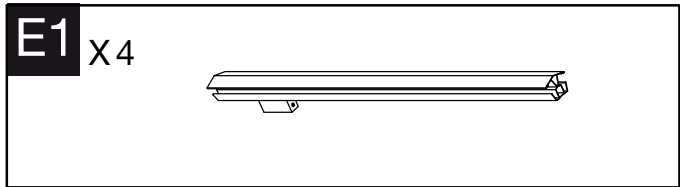
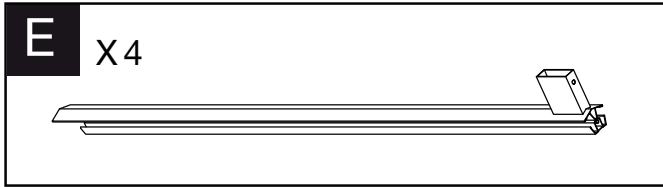
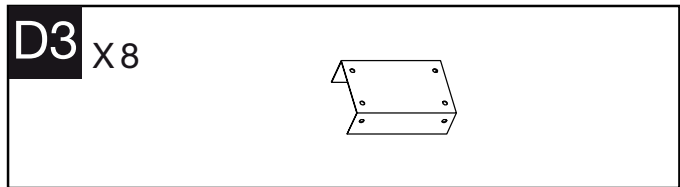
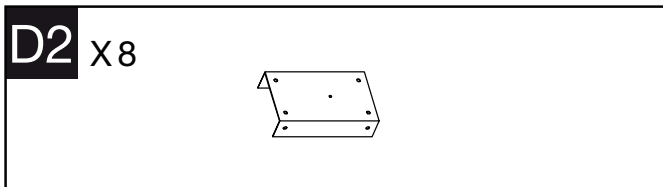
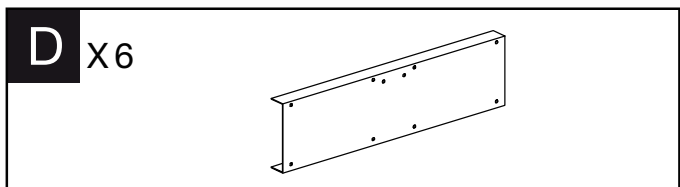
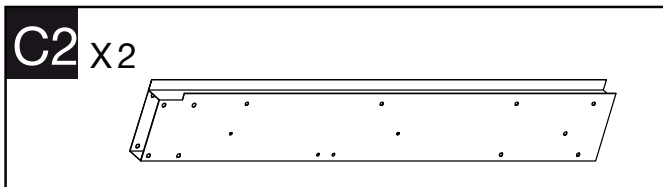
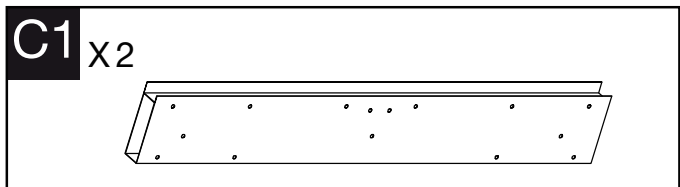
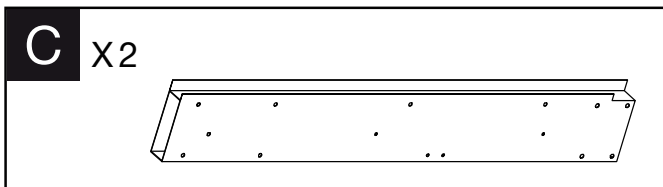
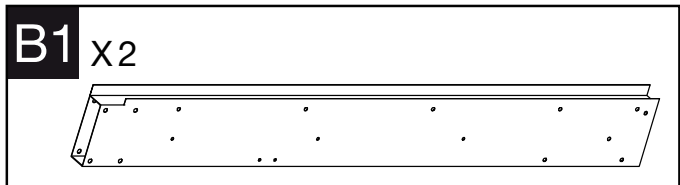
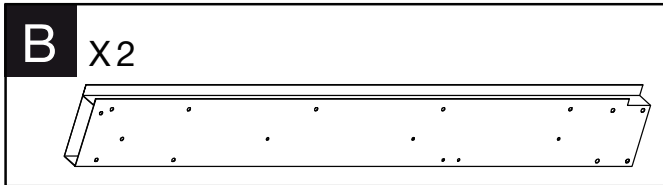
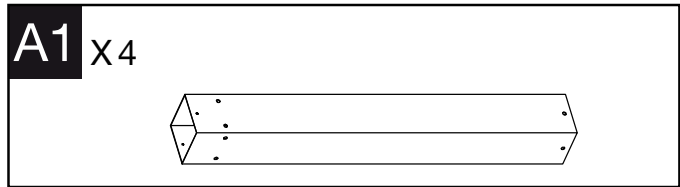
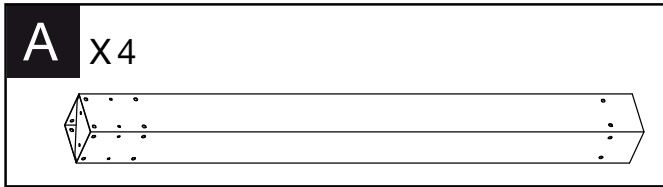

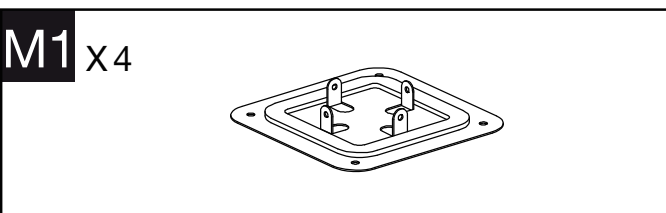
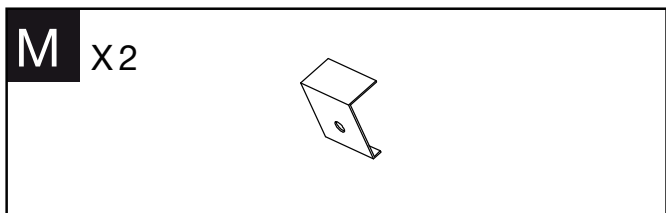
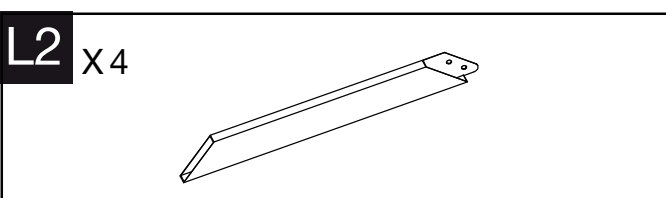
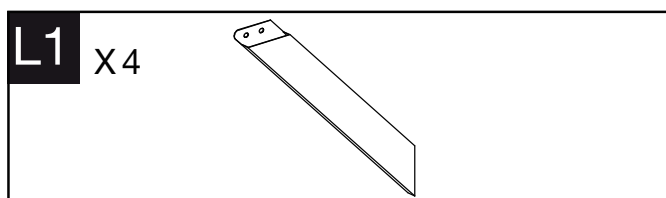
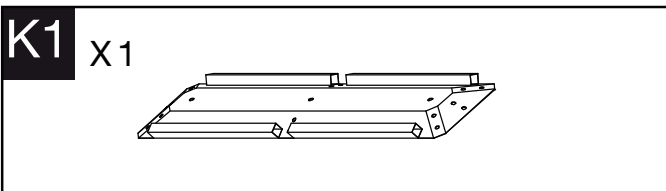
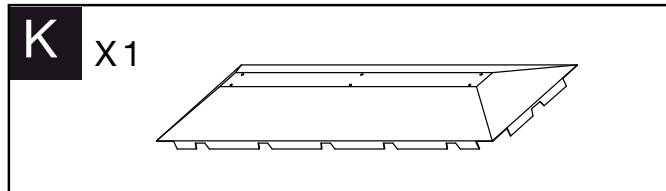
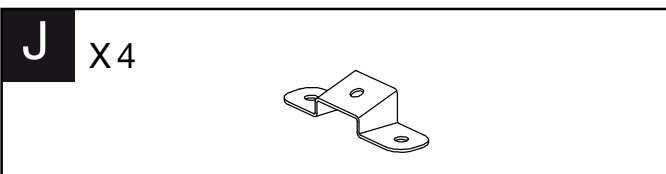
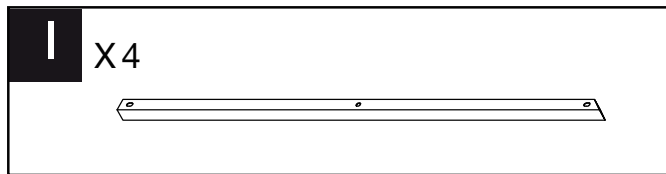
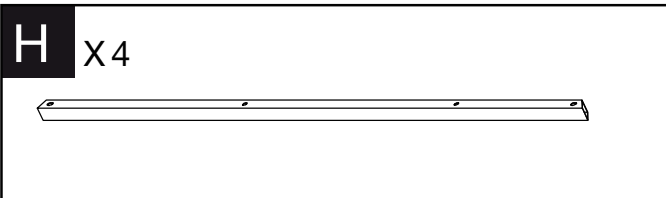
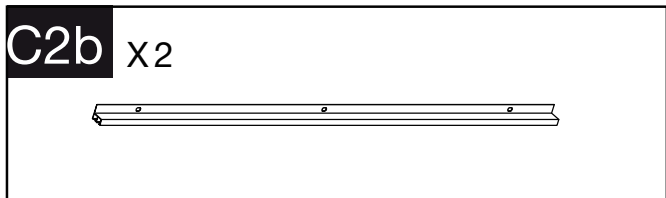
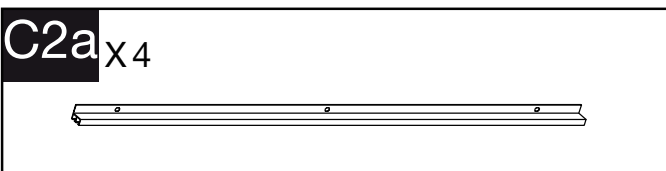
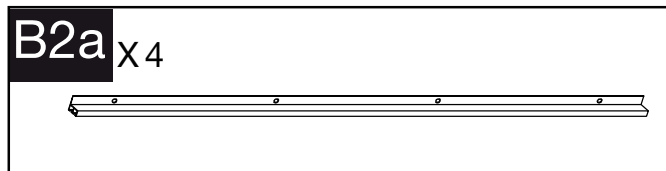
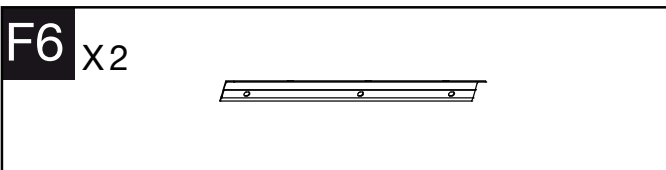
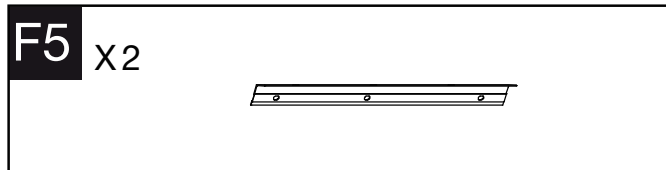
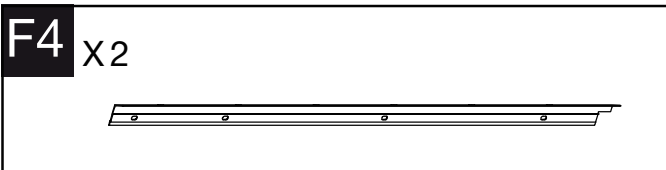
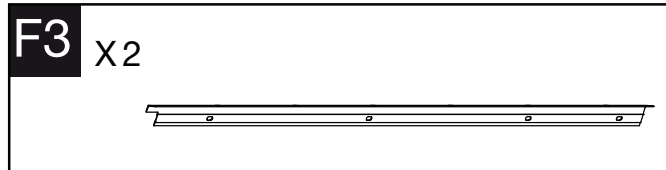

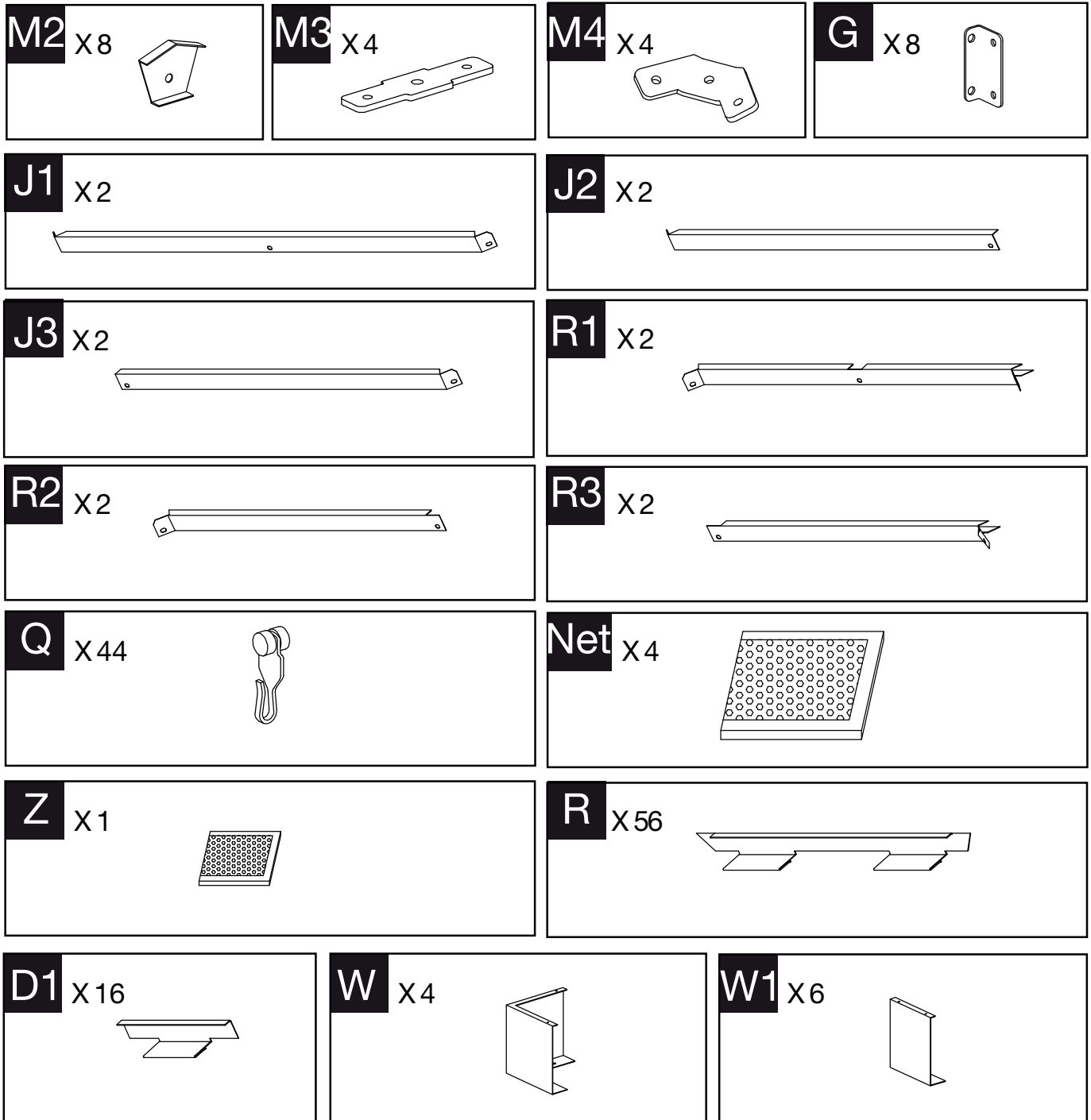

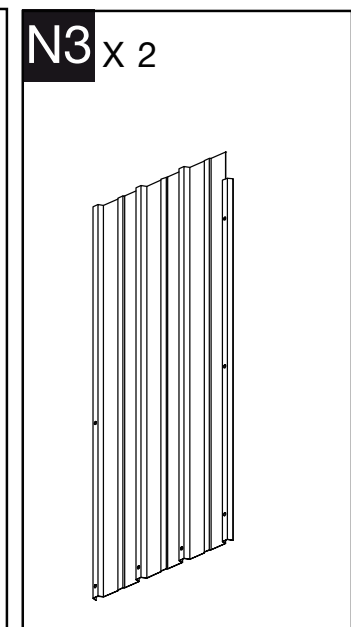
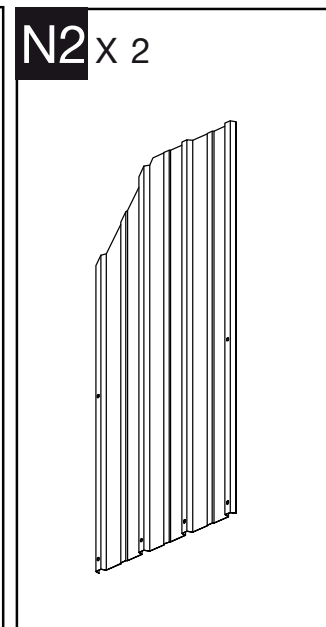
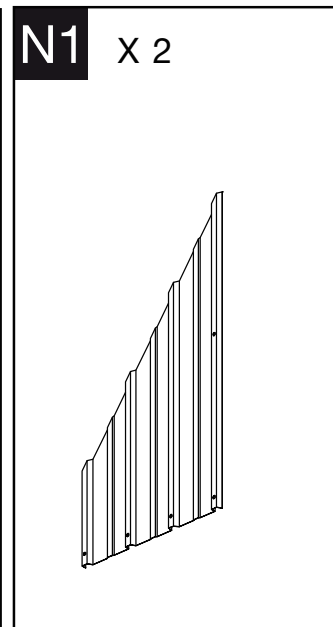
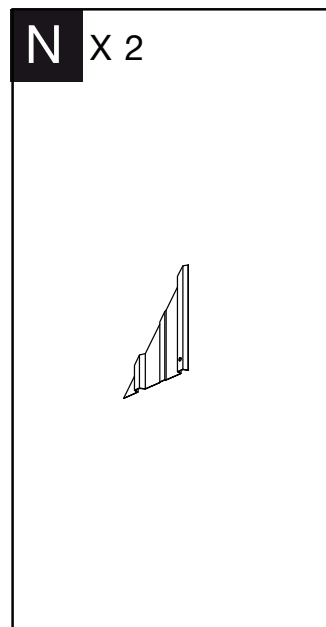
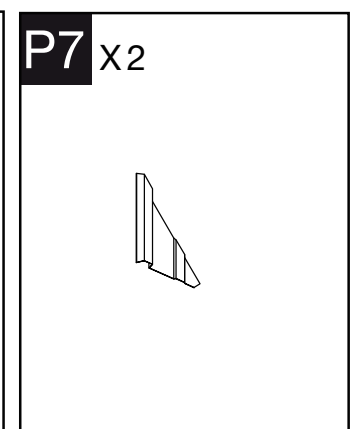
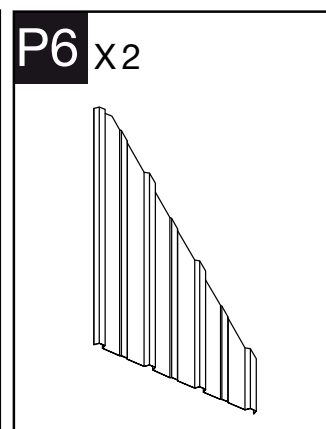
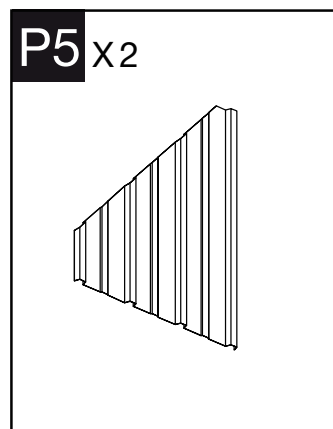
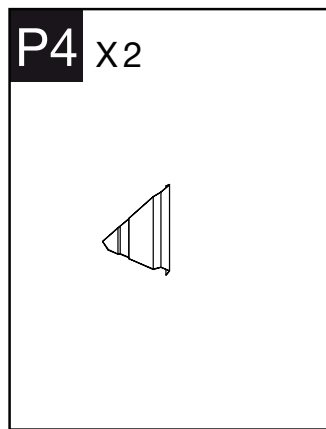
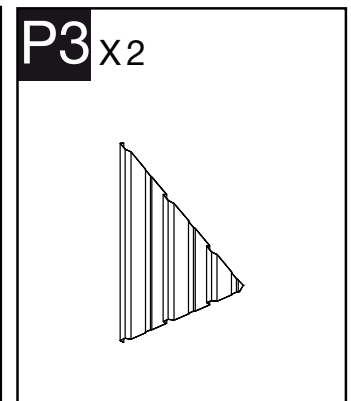
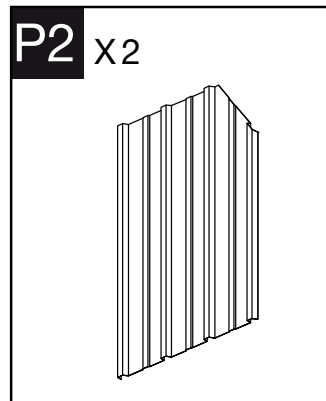
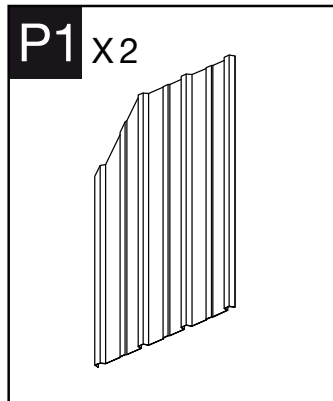
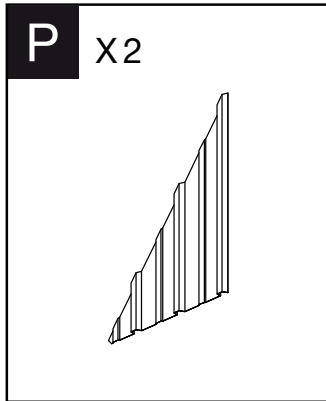

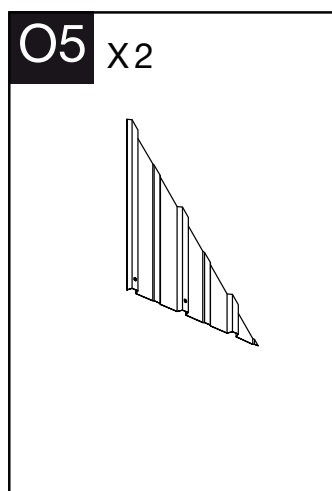
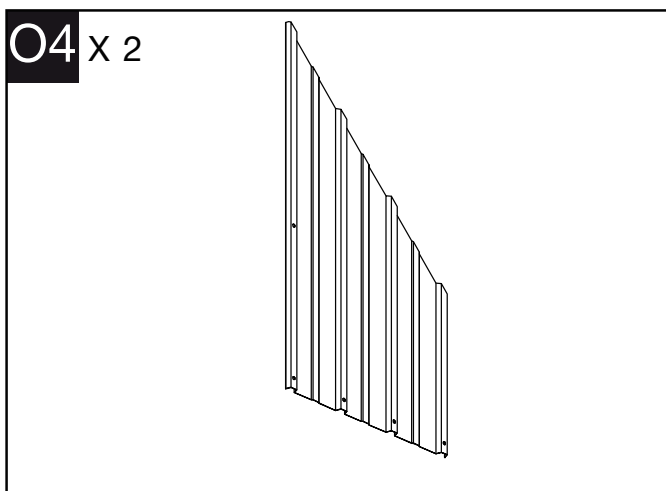
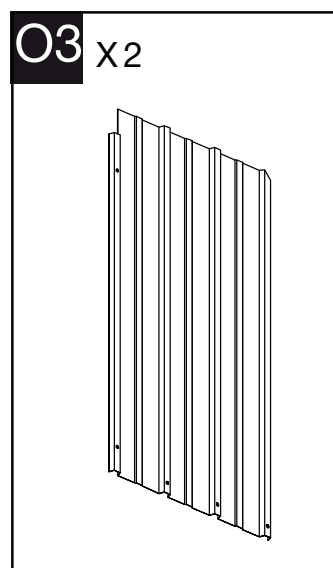
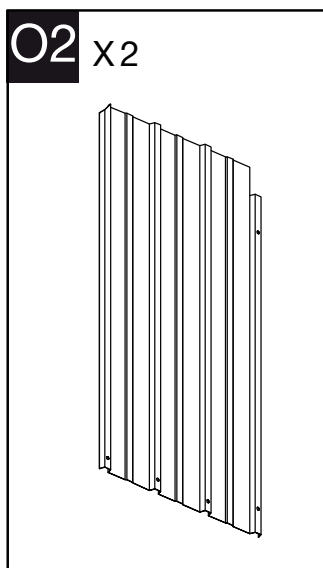
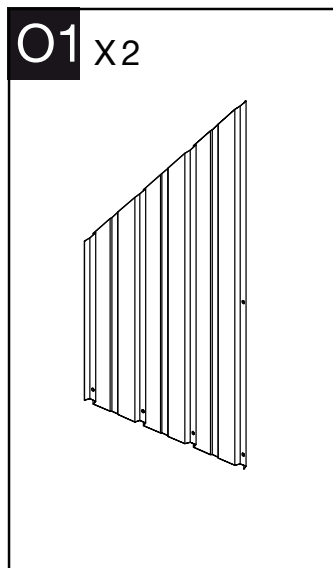
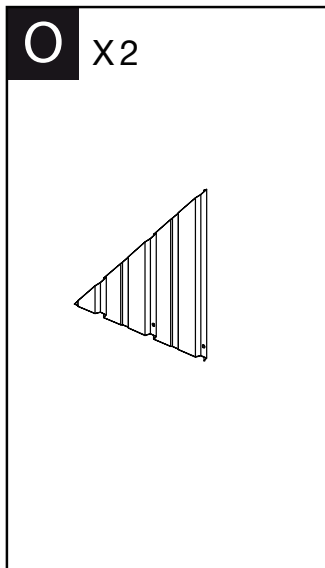
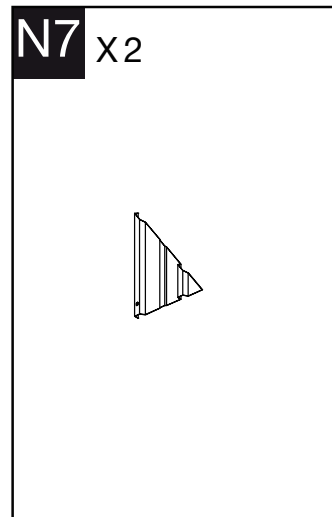
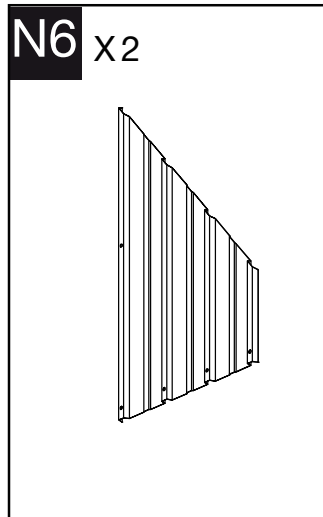
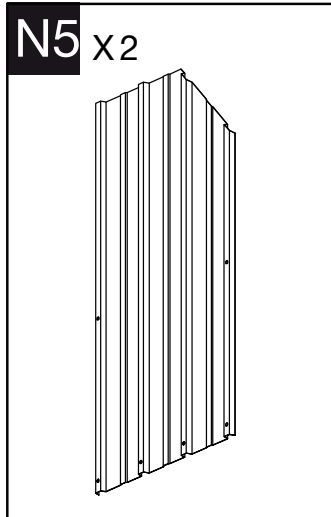
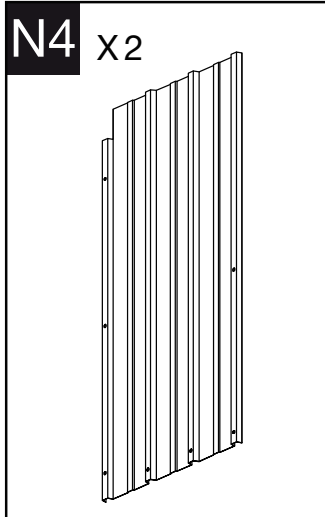

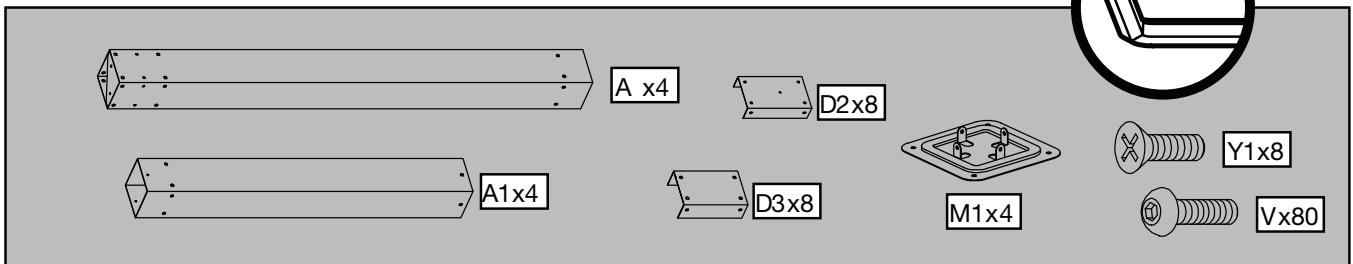
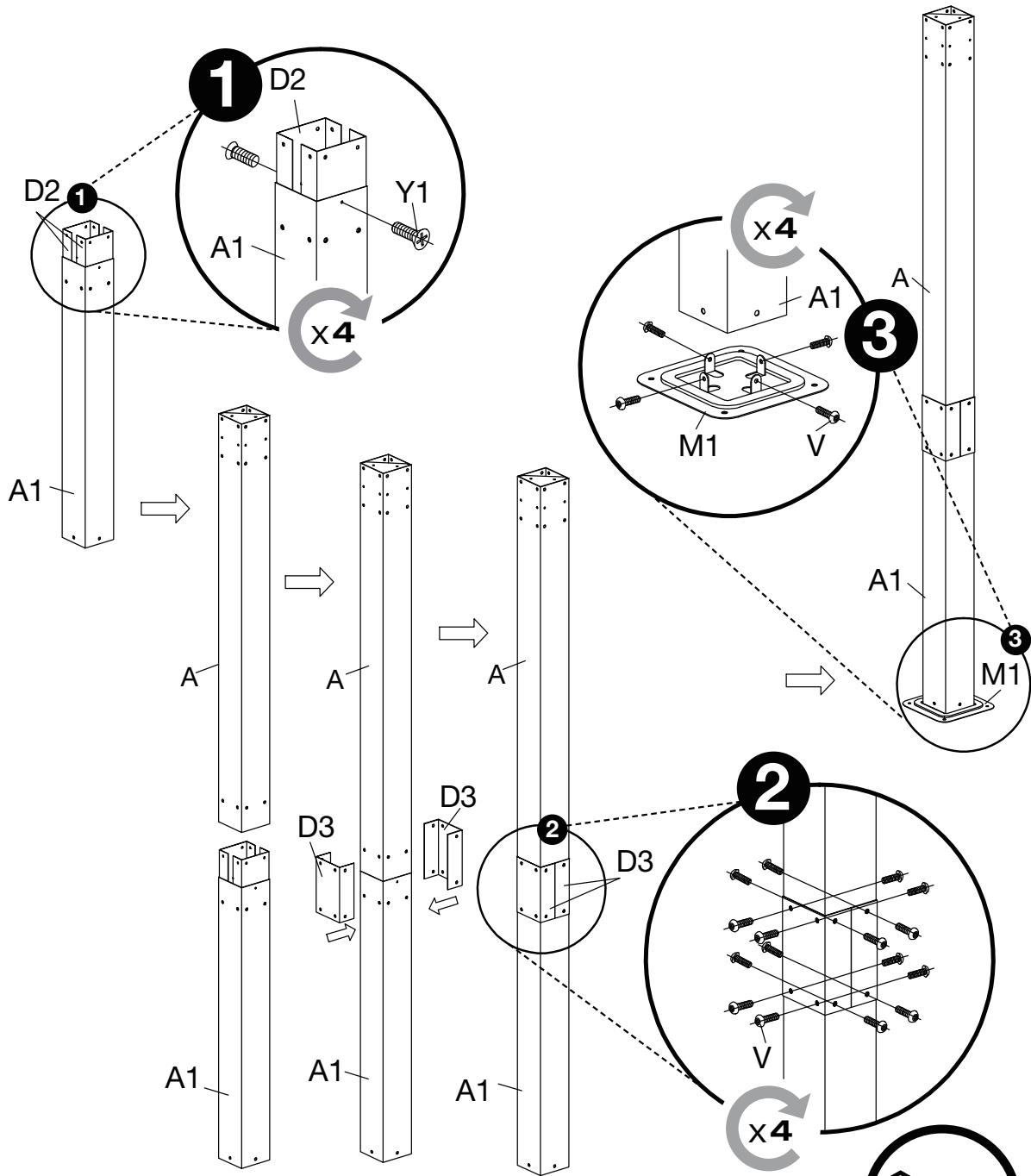

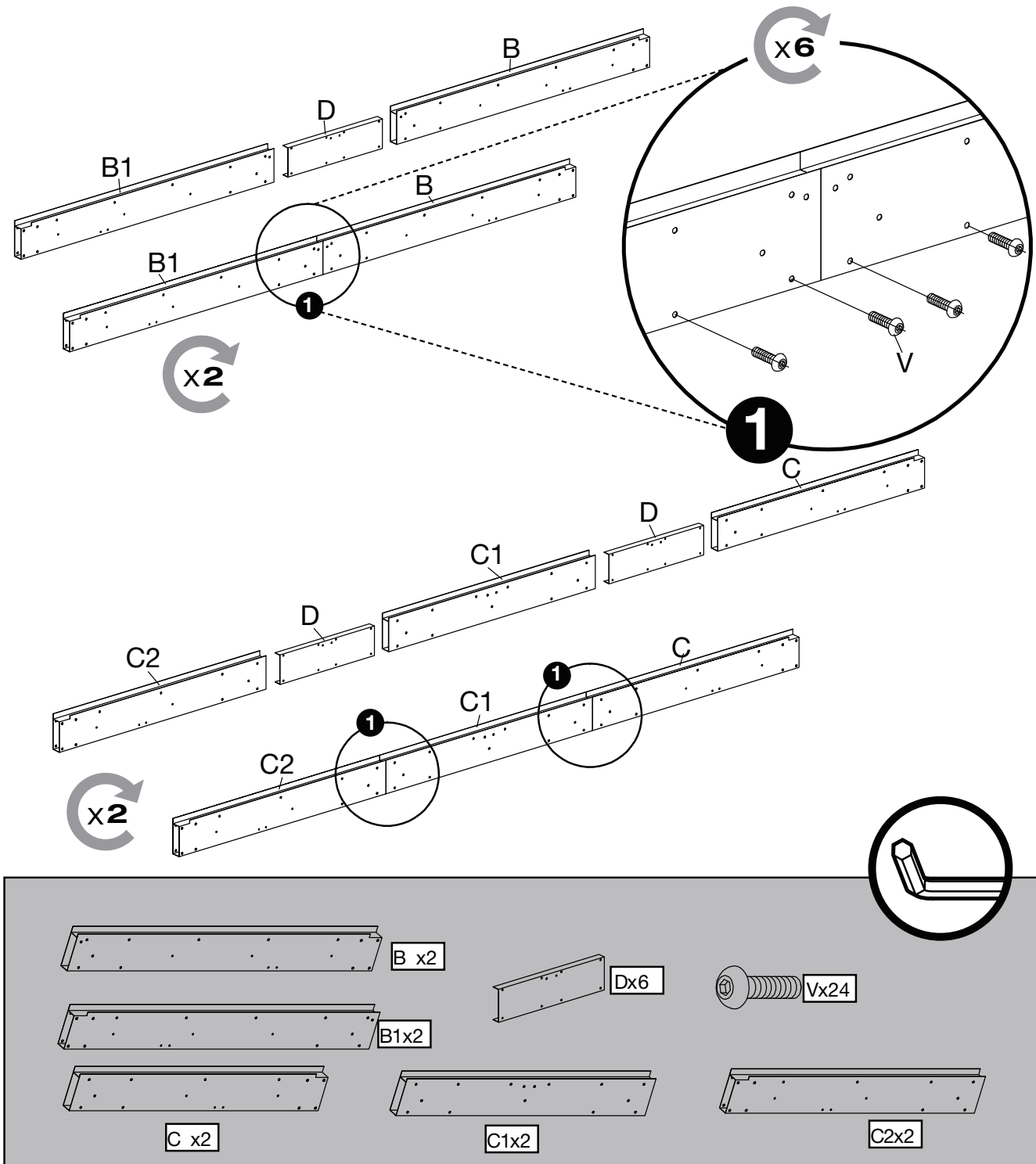

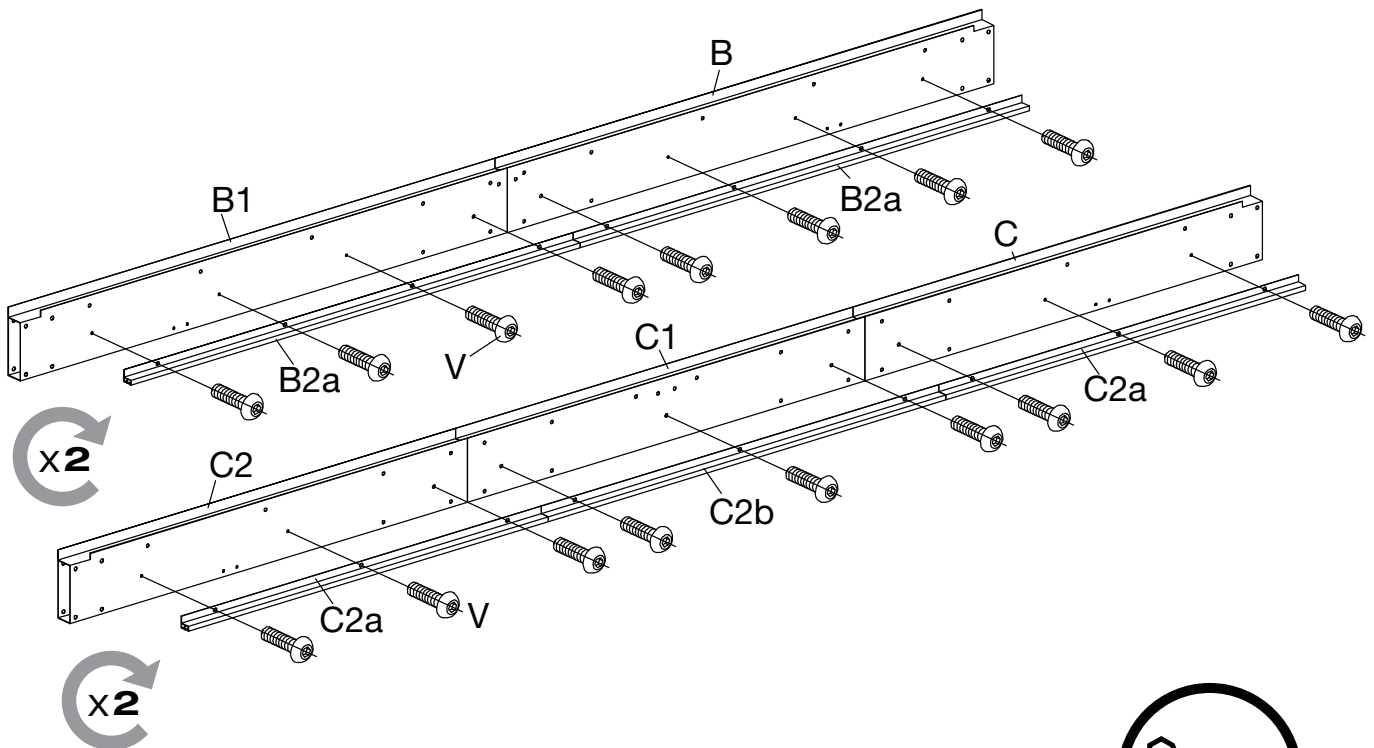
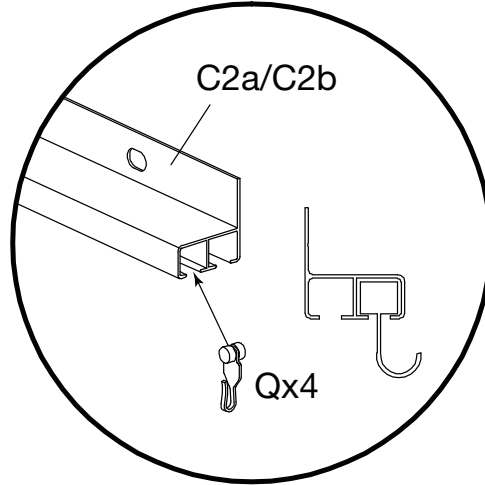
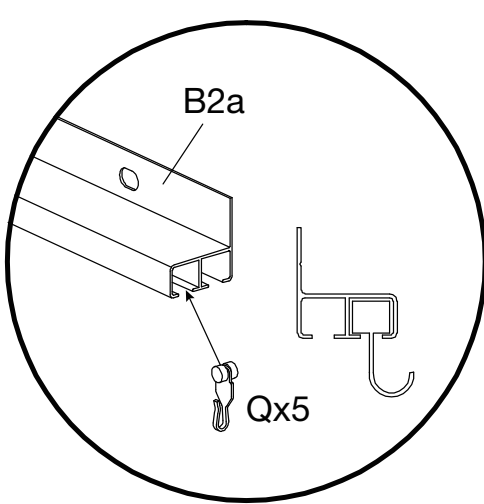

A parts list and assembly icon. The parts list includes:

- B2a x4
- C2a x4
- C2b x2
- V x34
- Q x44

To the right is a circular icon showing a hook-shaped component.

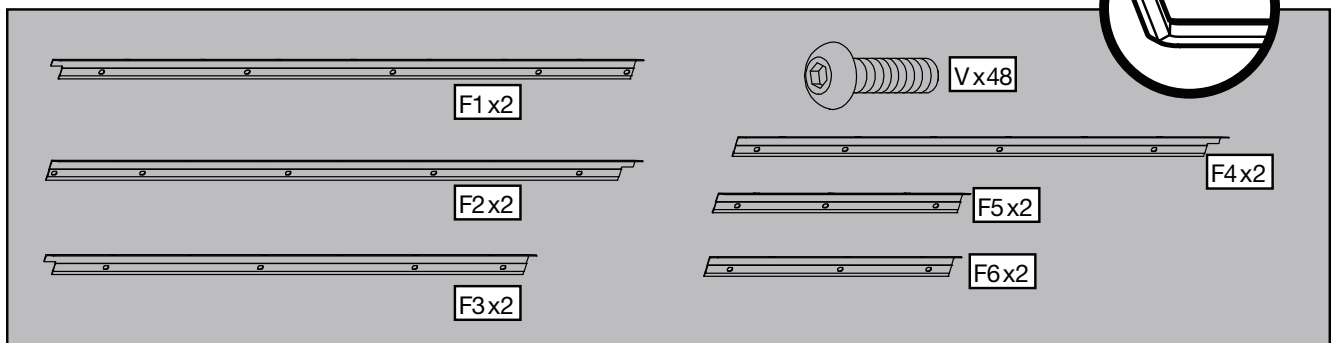
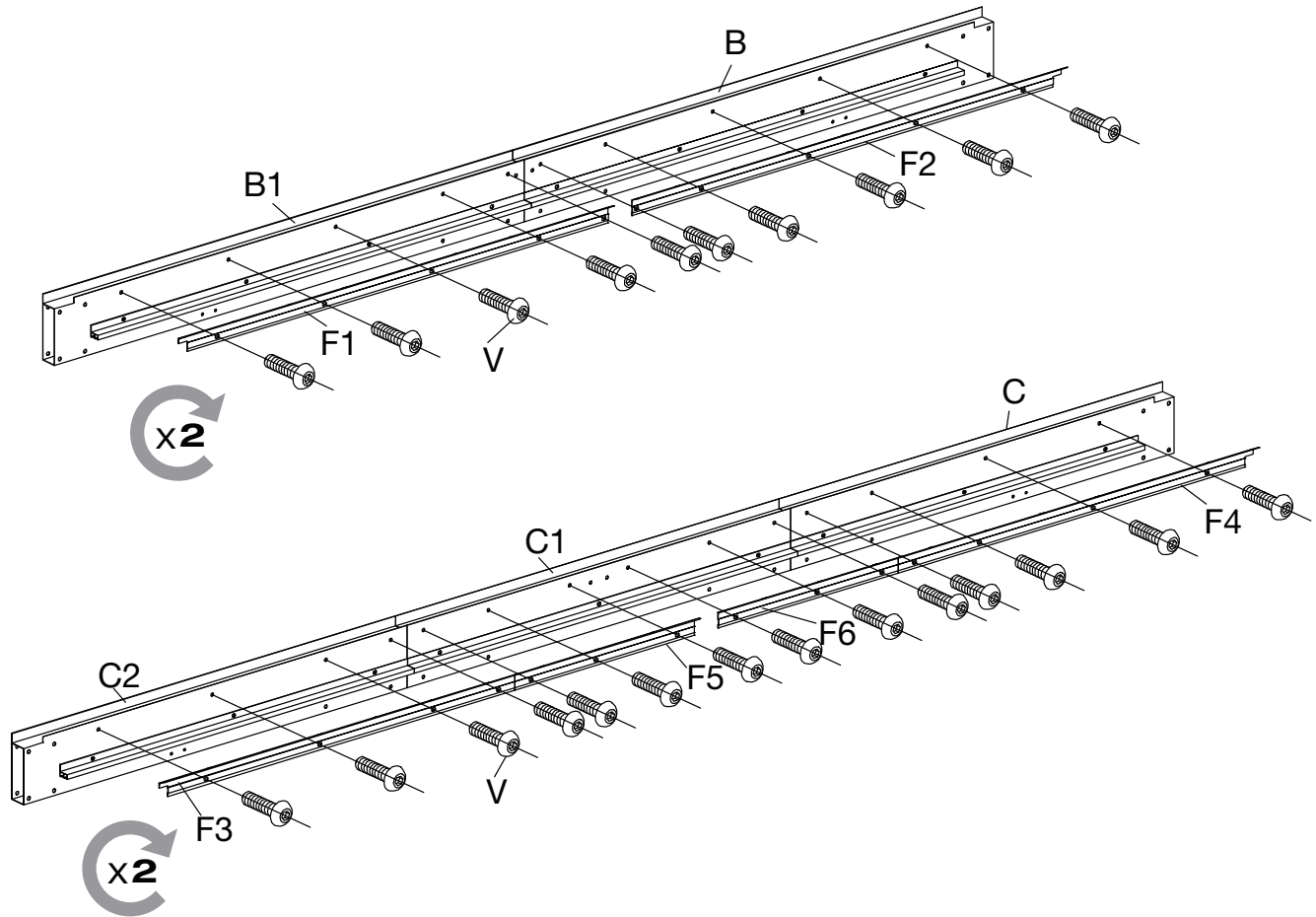

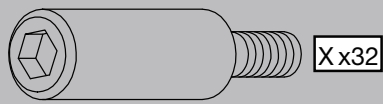
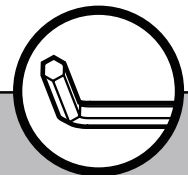
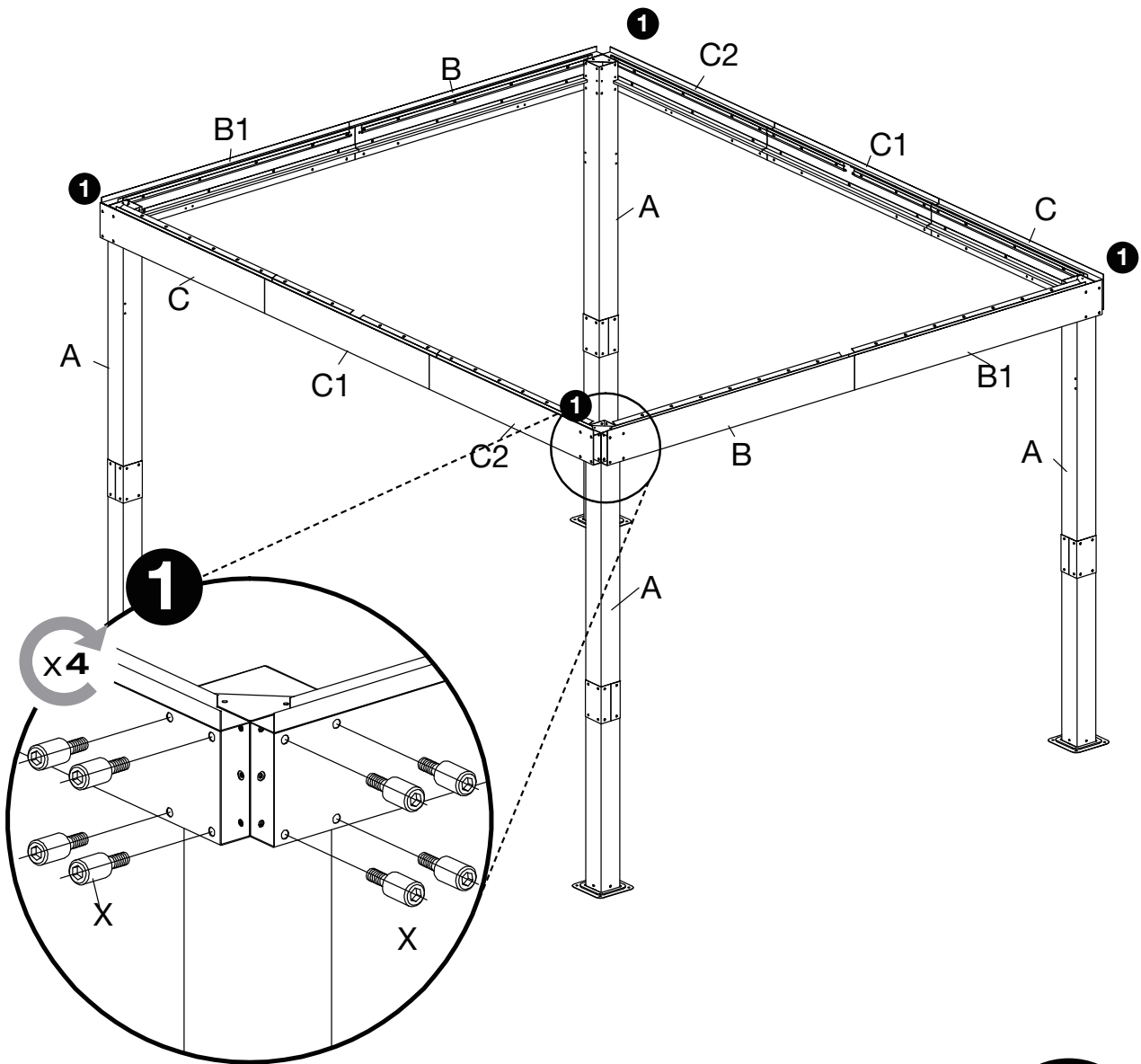

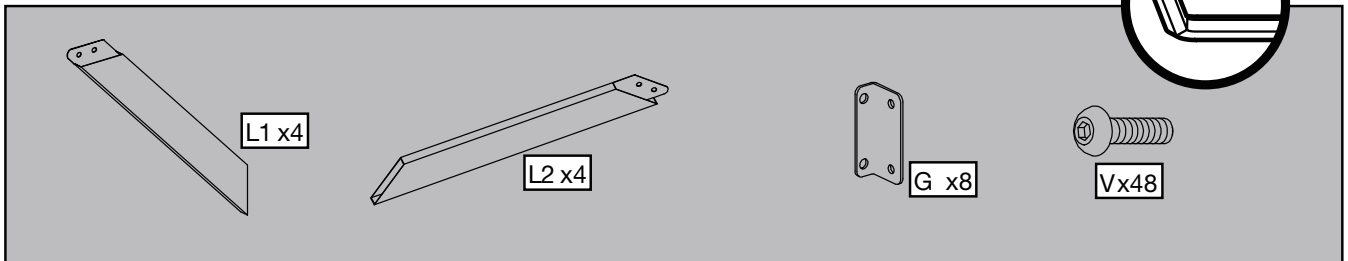
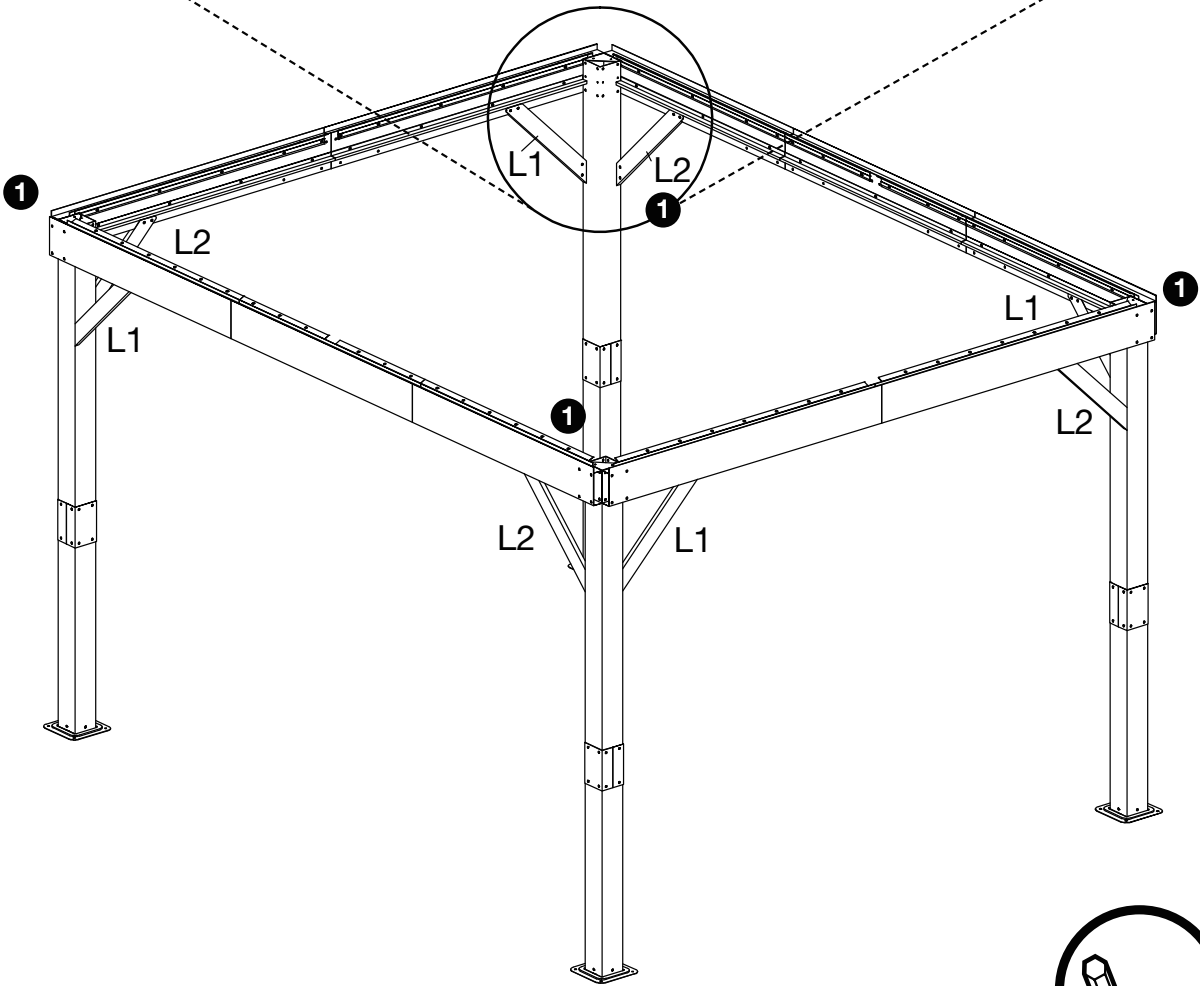
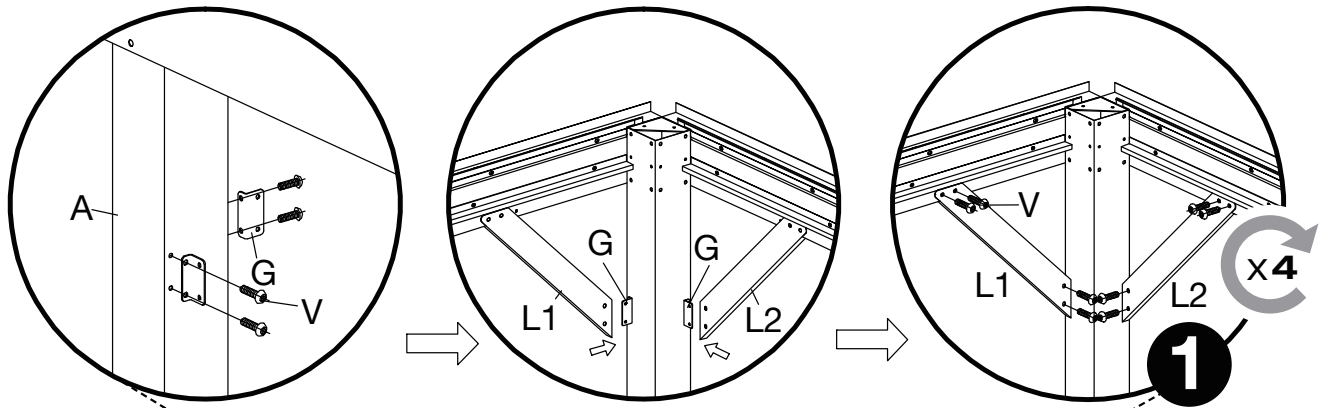

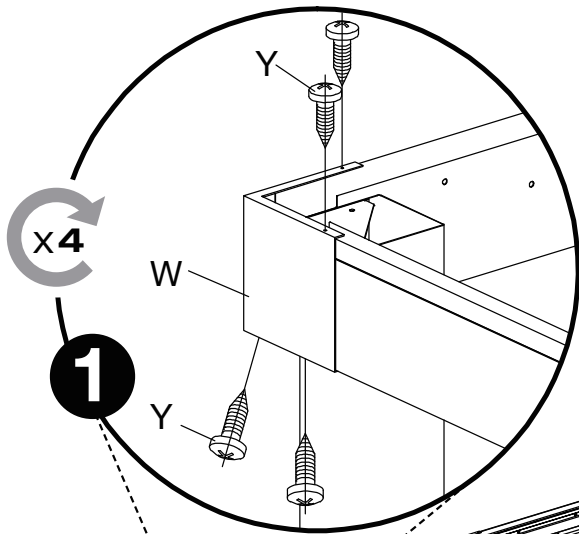

1

x4

W

Y

1

2

2

2

1

2

2

2

1

1

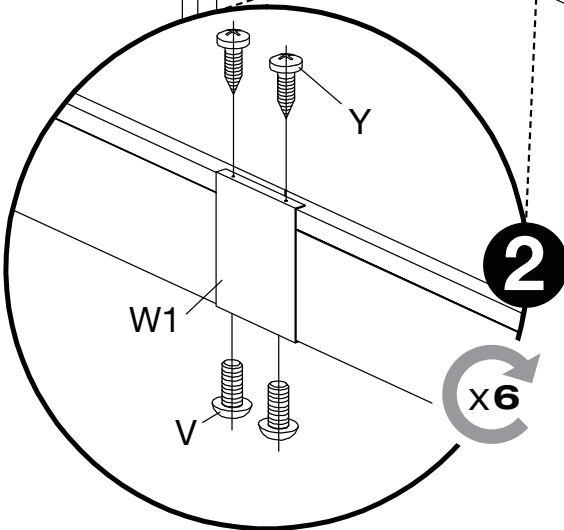

2

x6

W1

V

Y

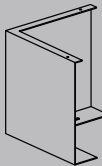
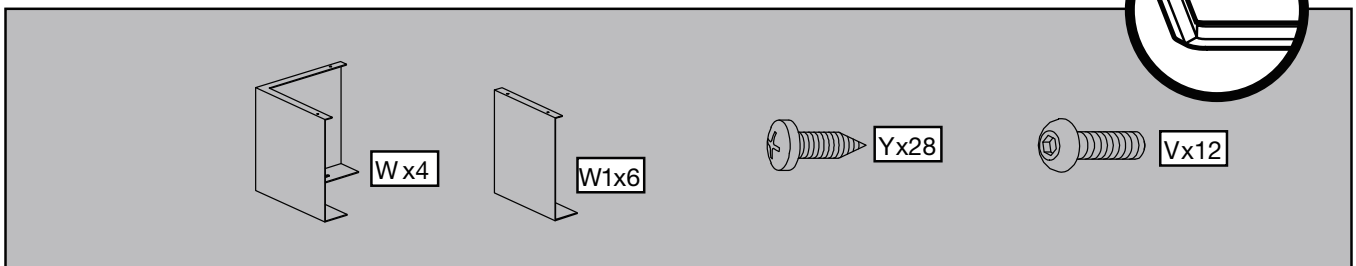
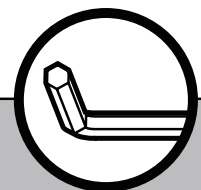

W x4

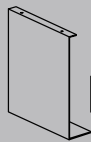

W1 x6

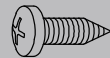

Y x28

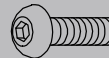

V x12

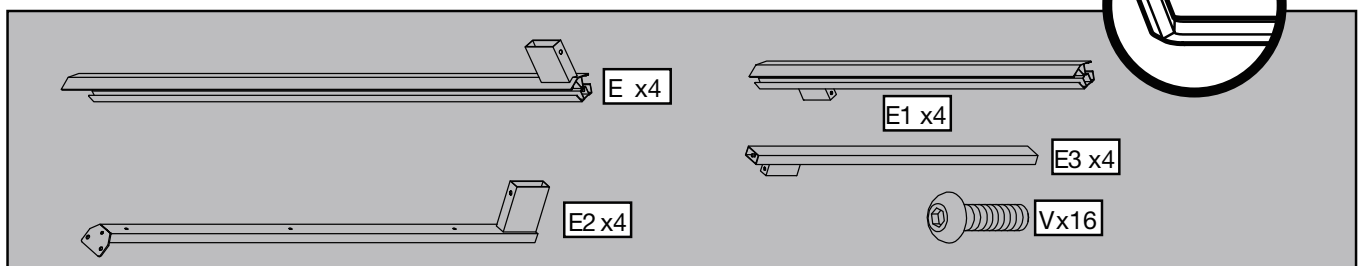
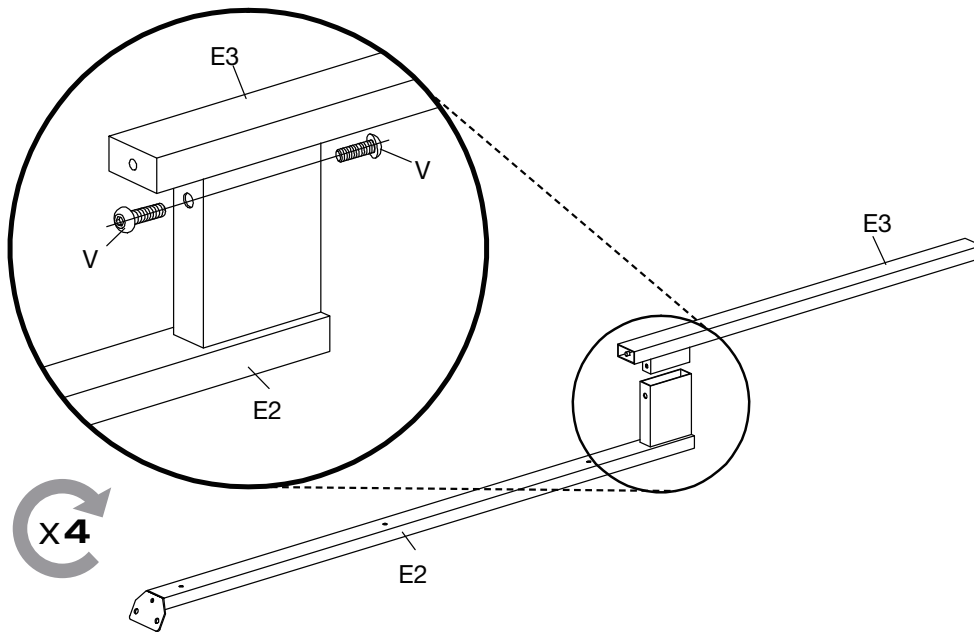
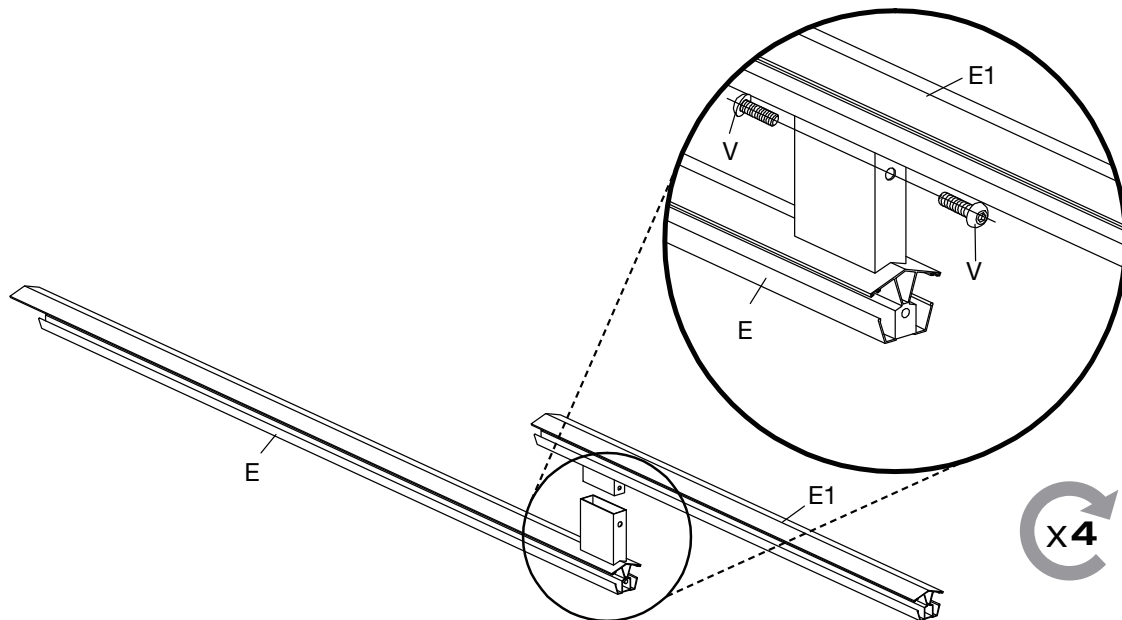

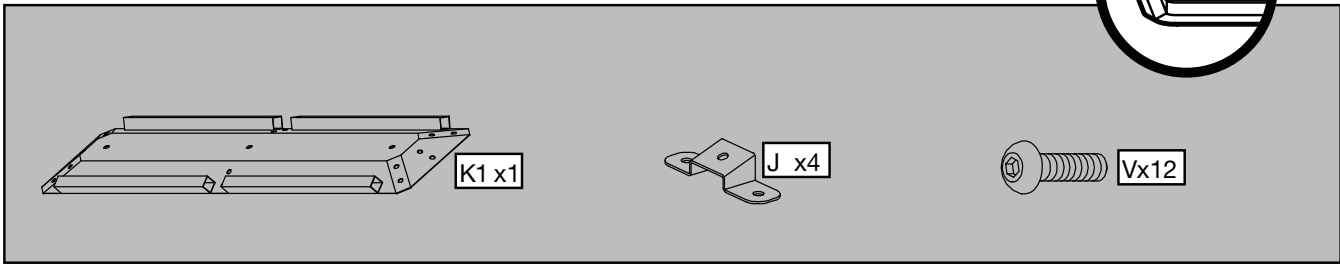
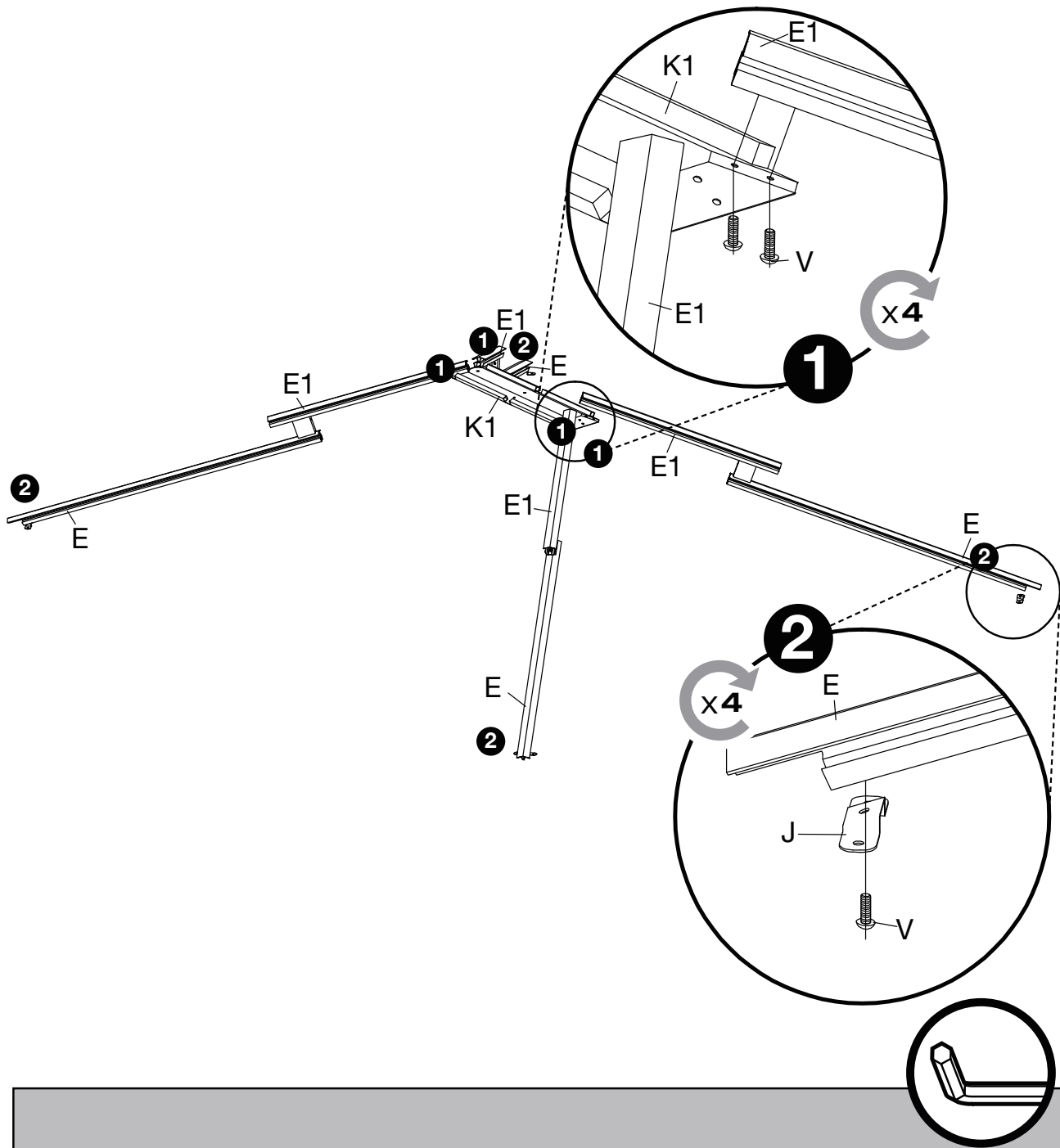

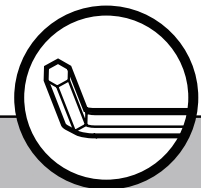
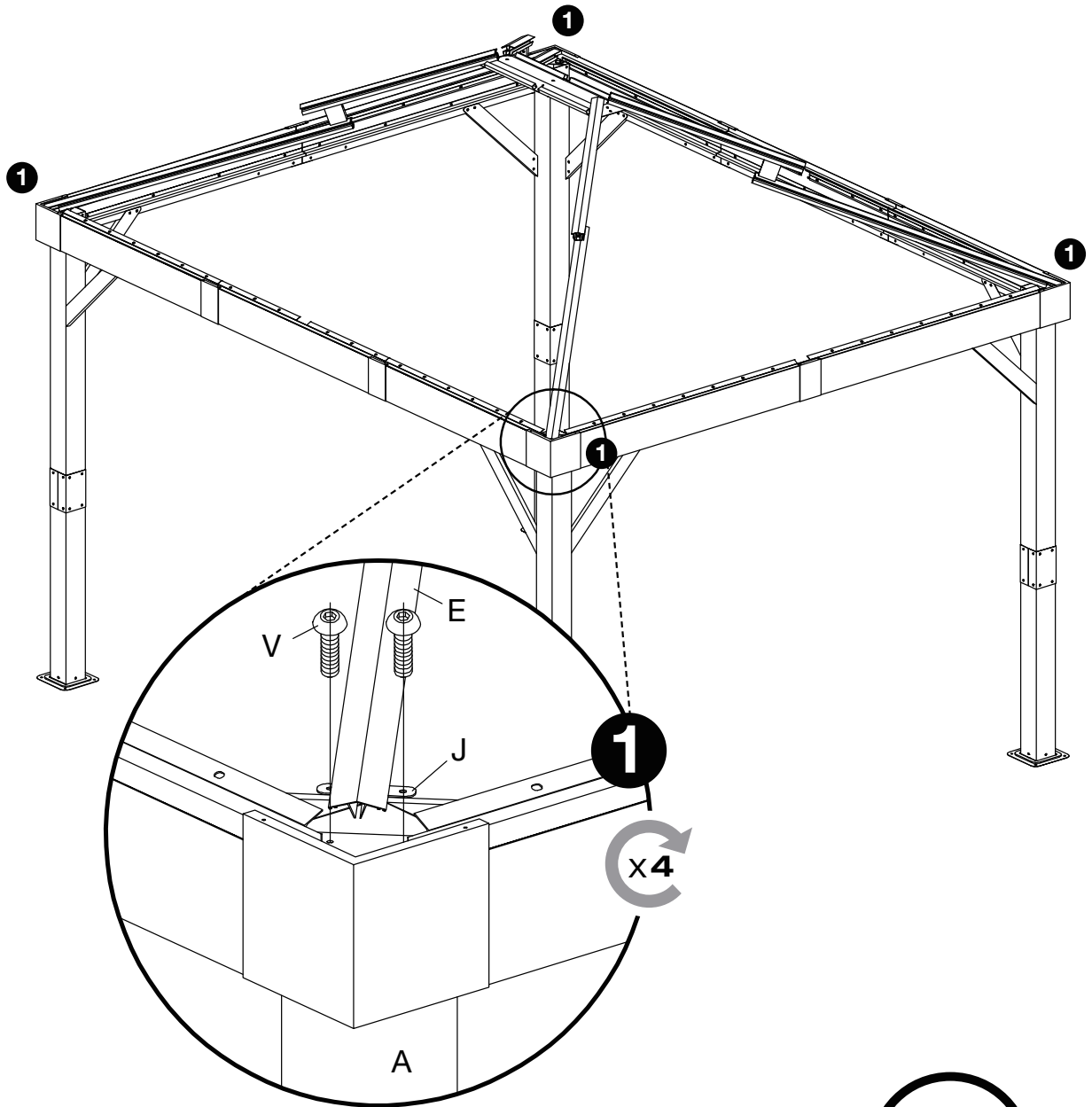

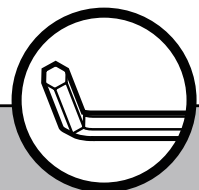
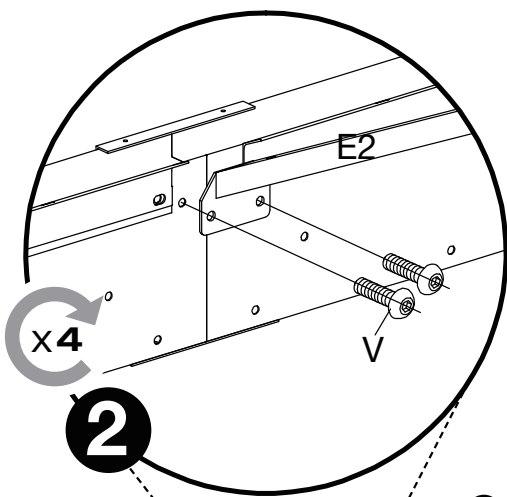
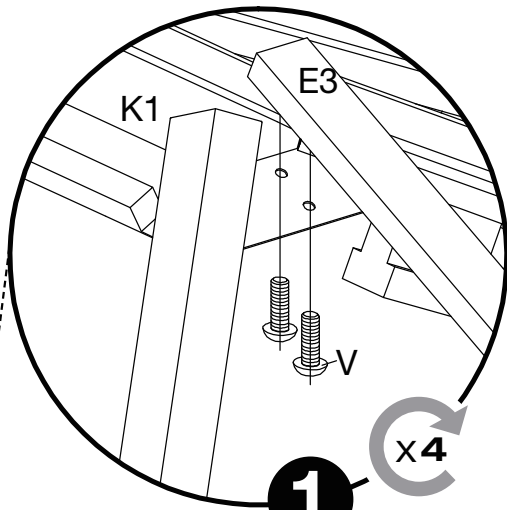
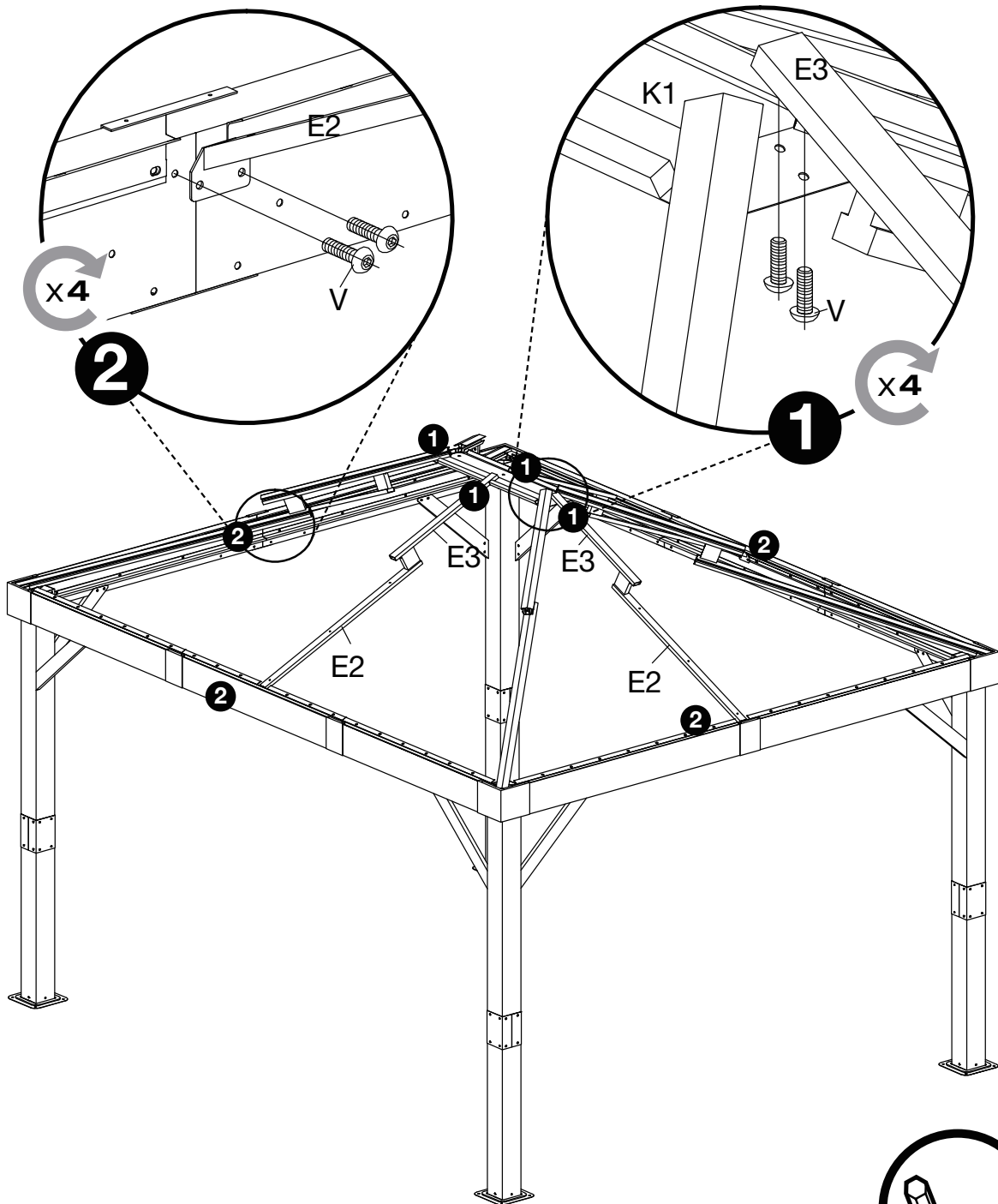

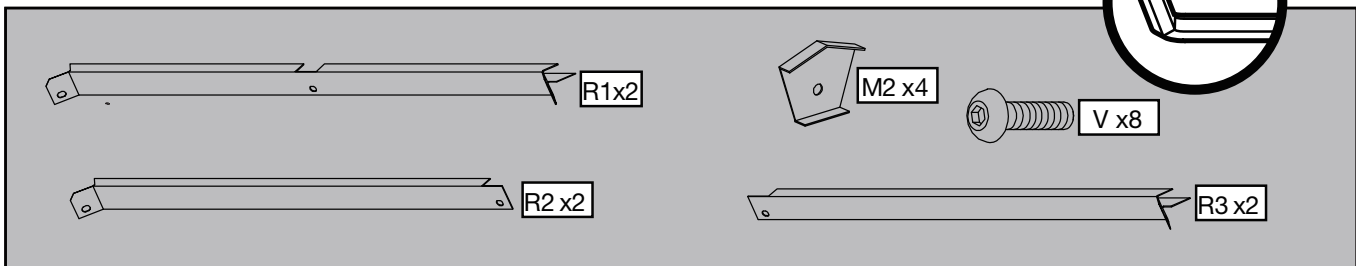
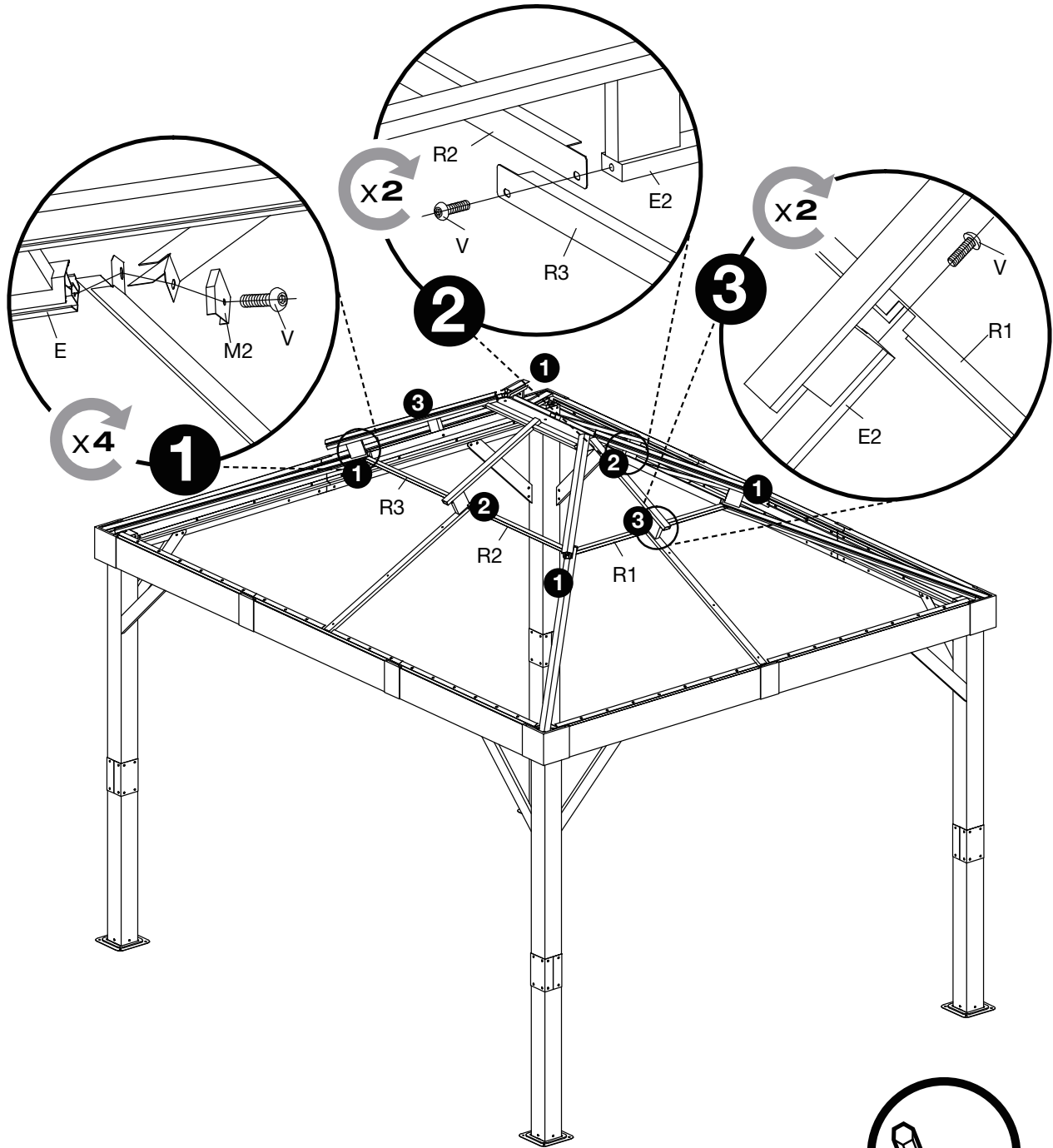

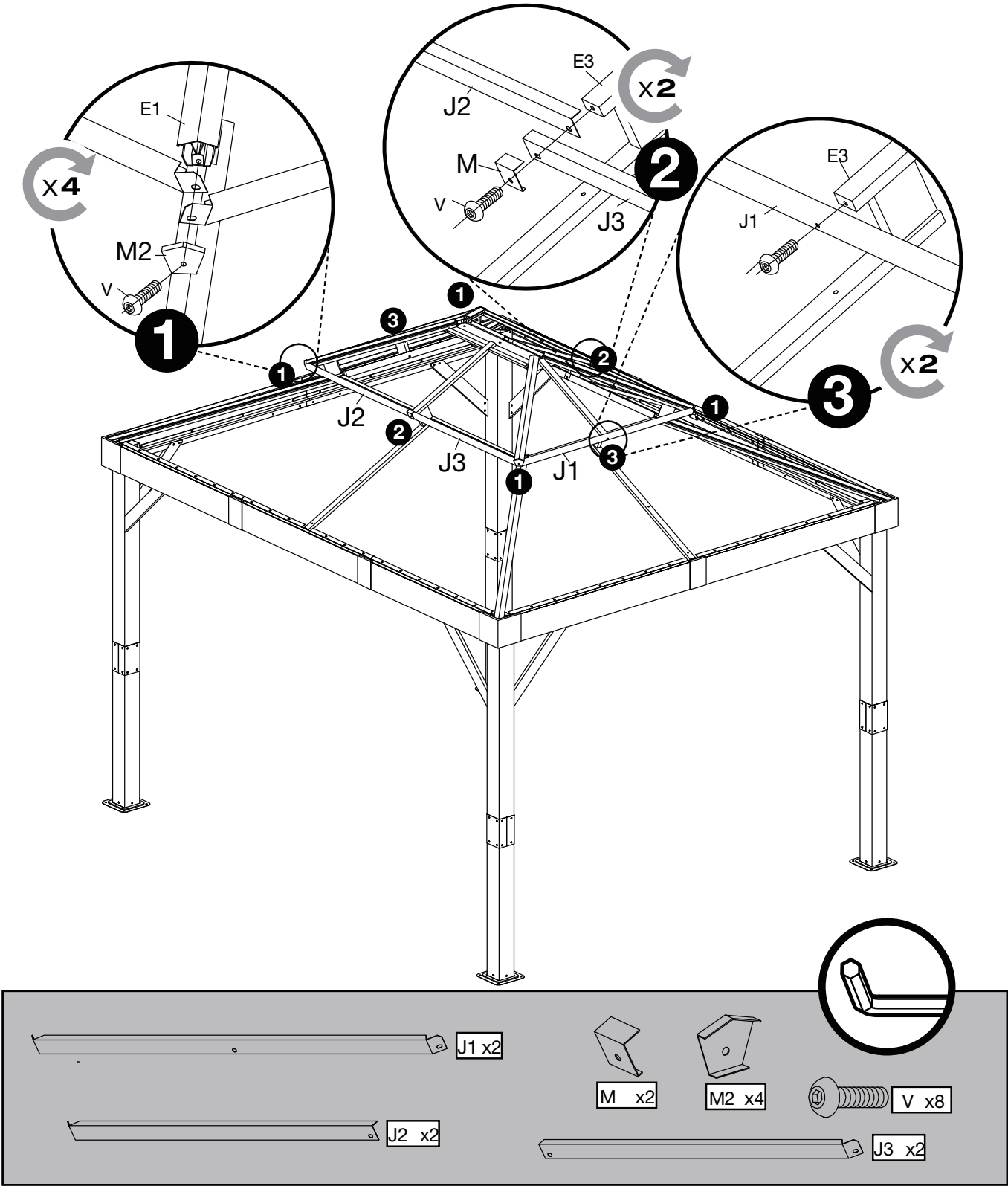

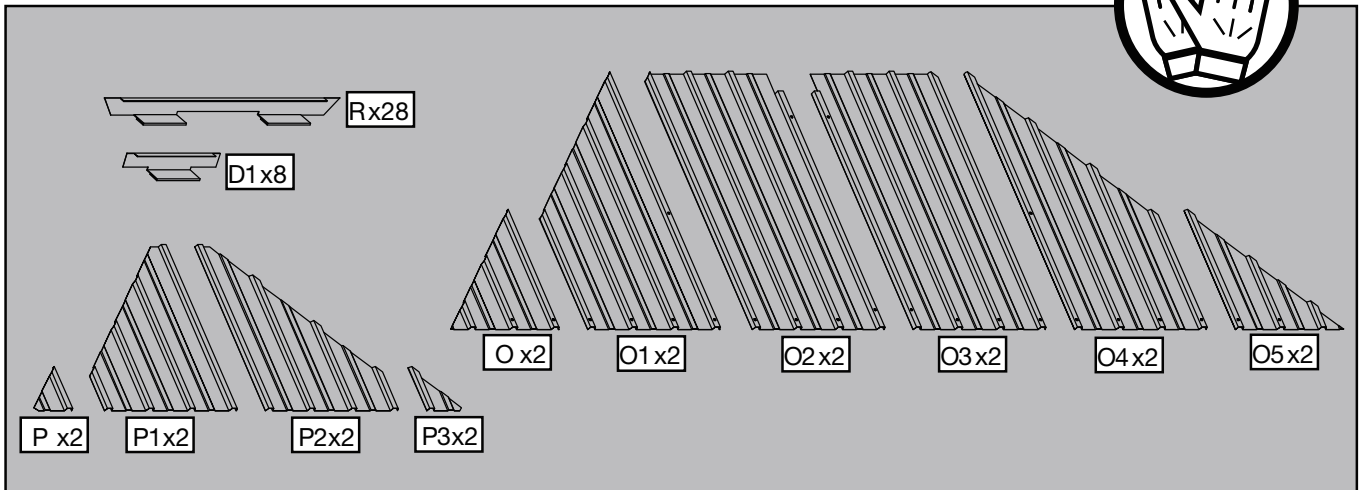
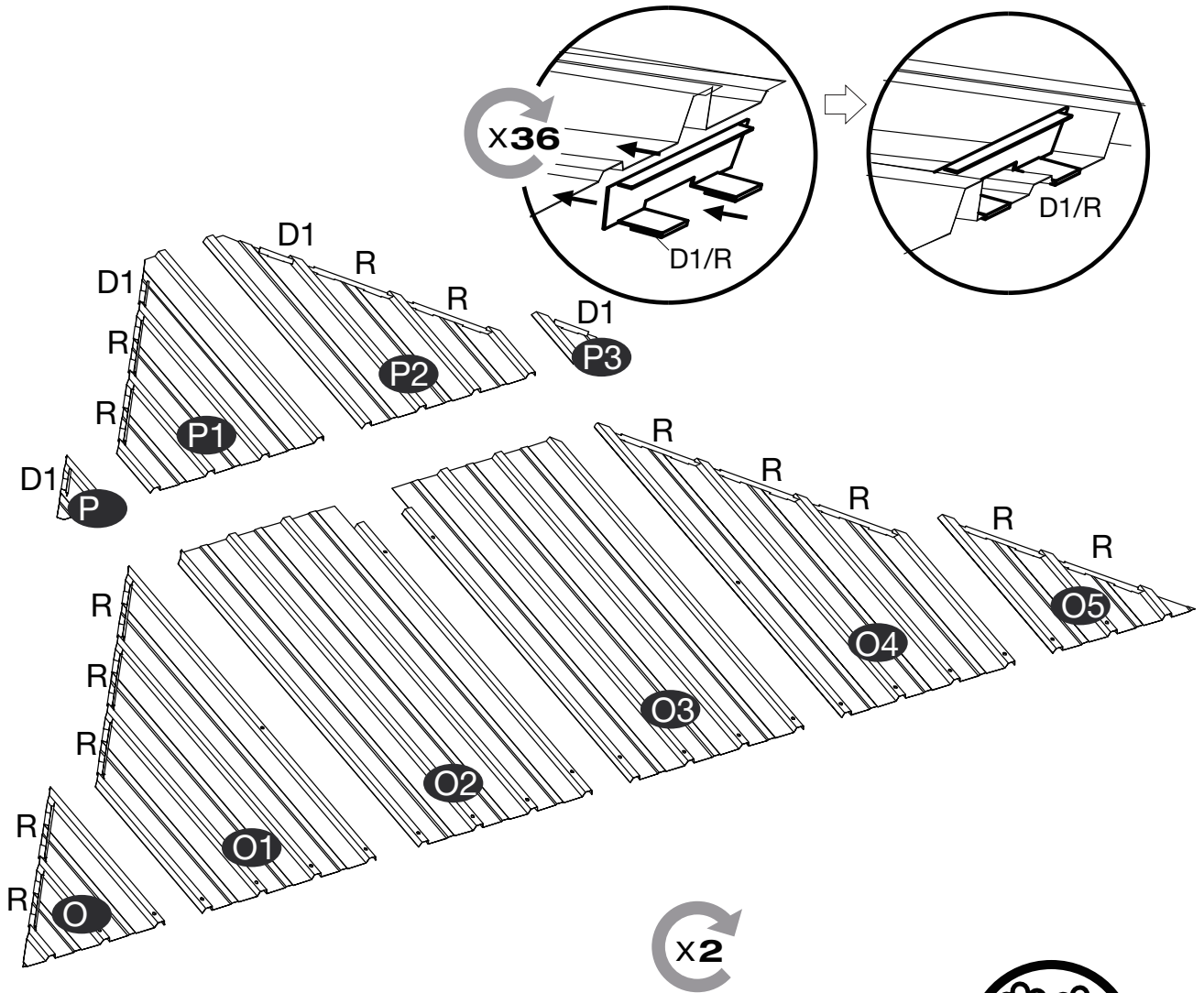

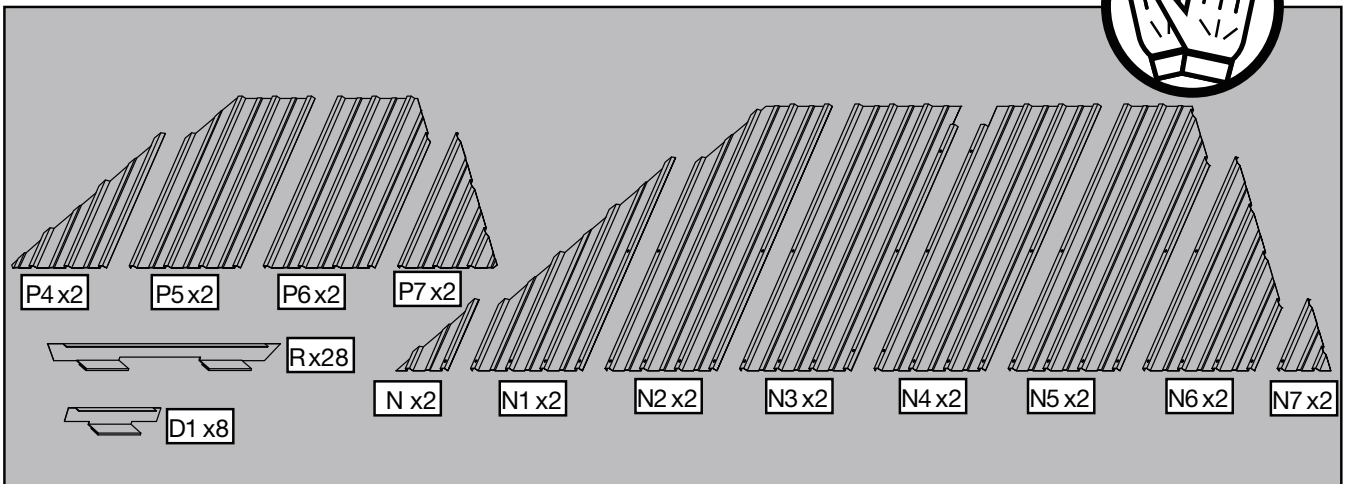
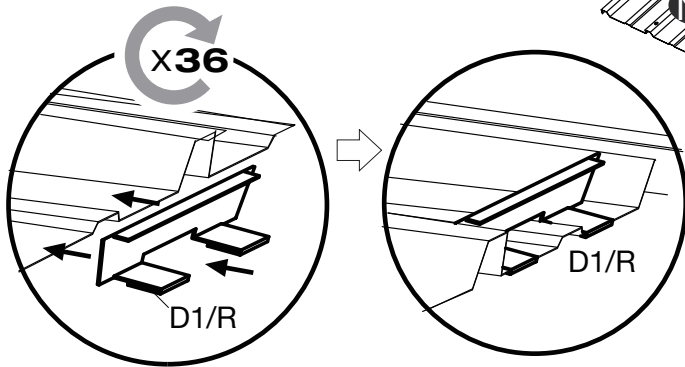
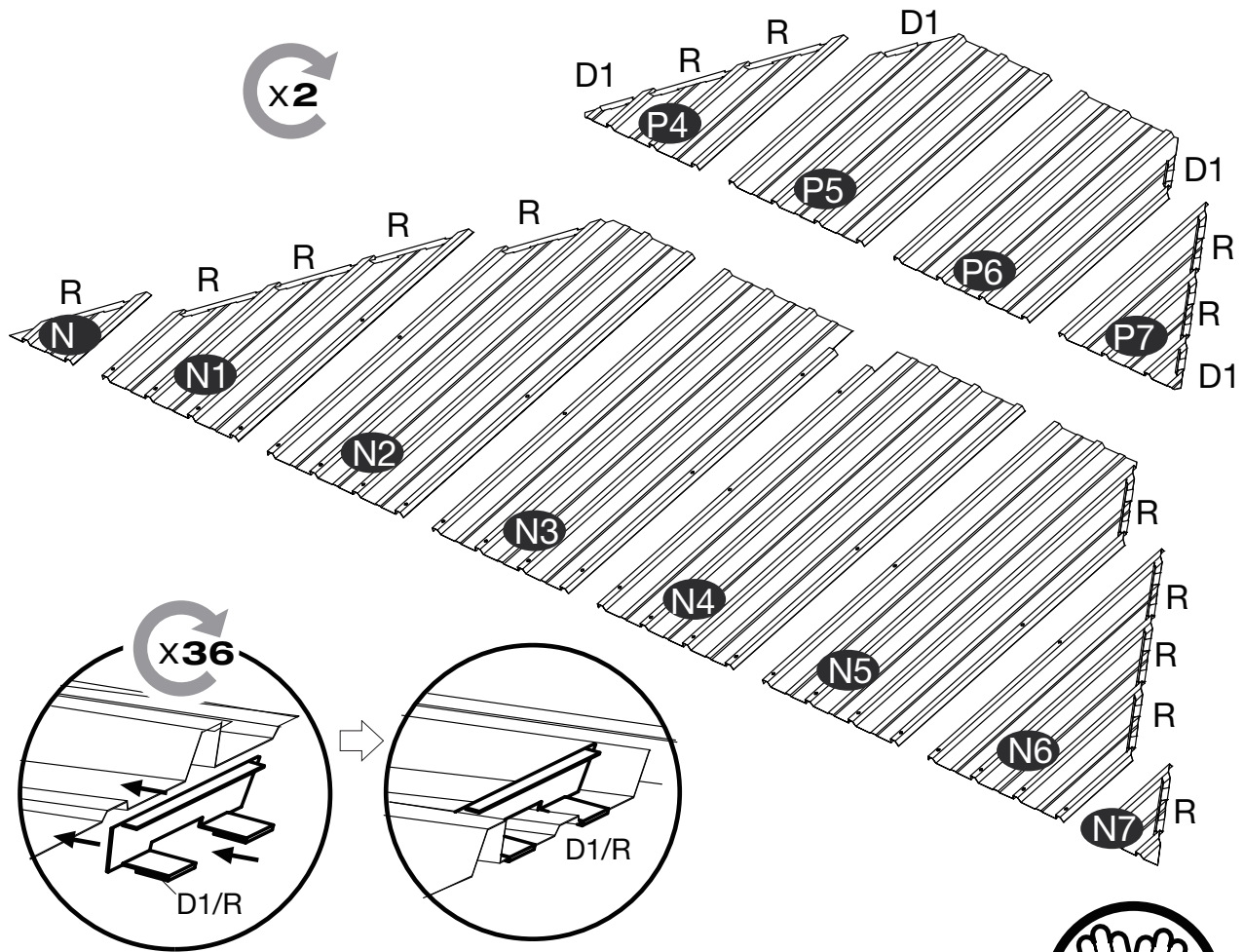

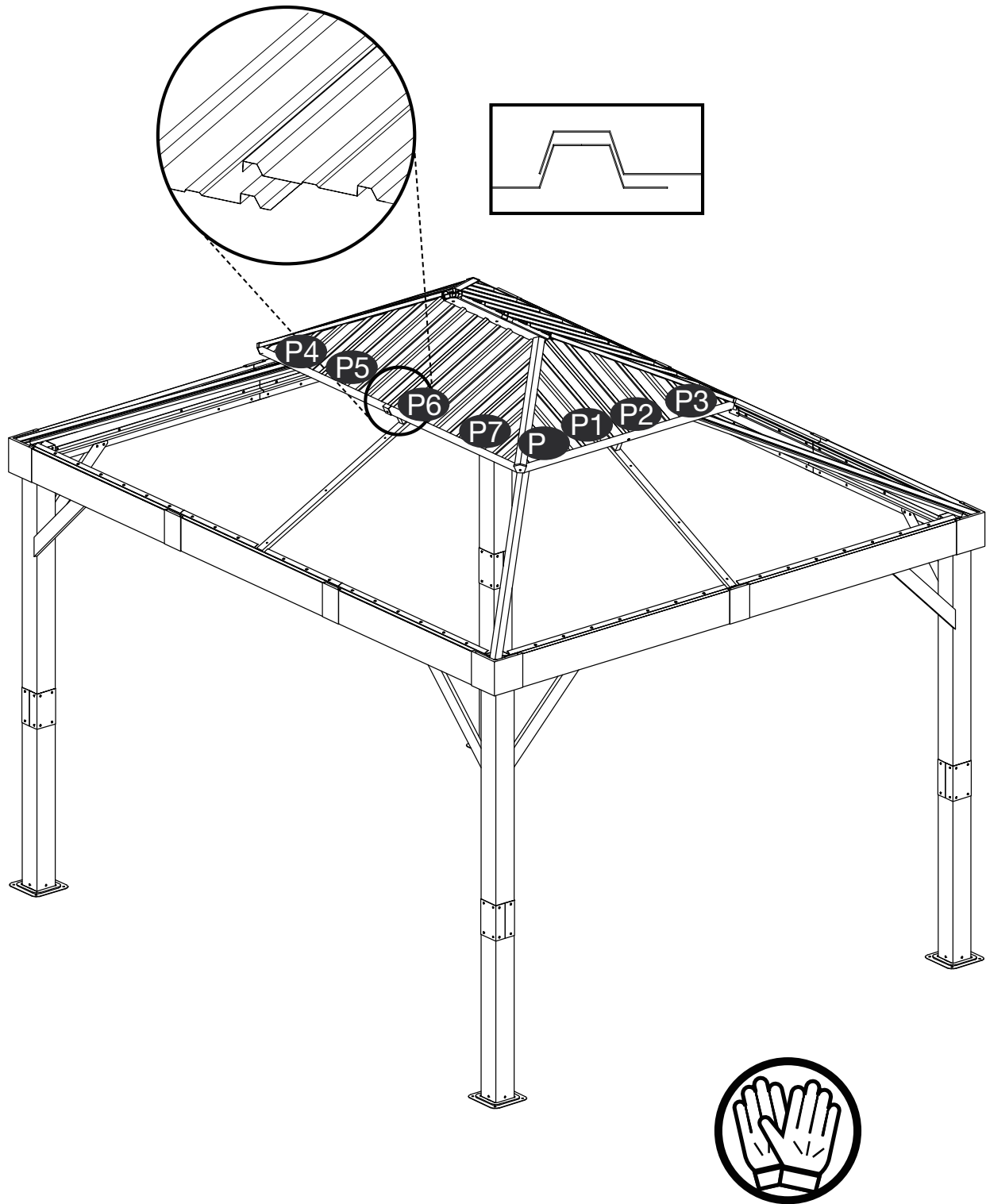

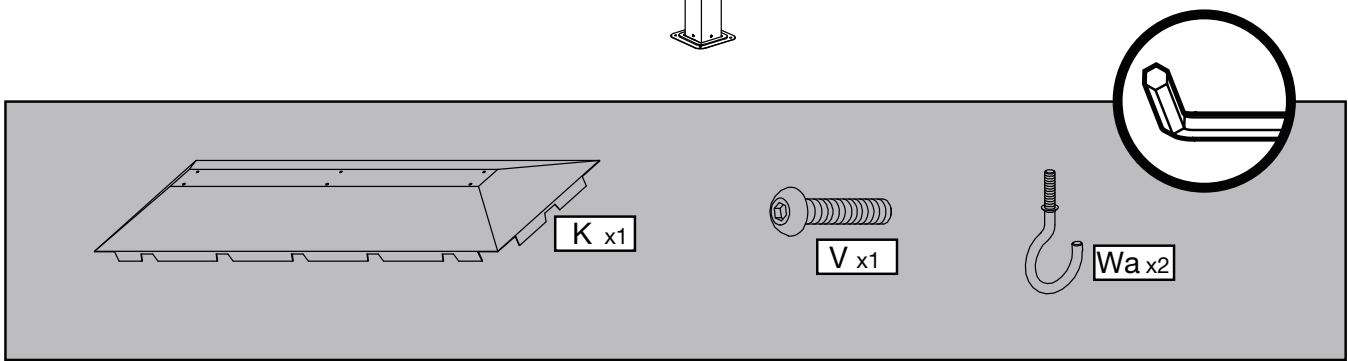
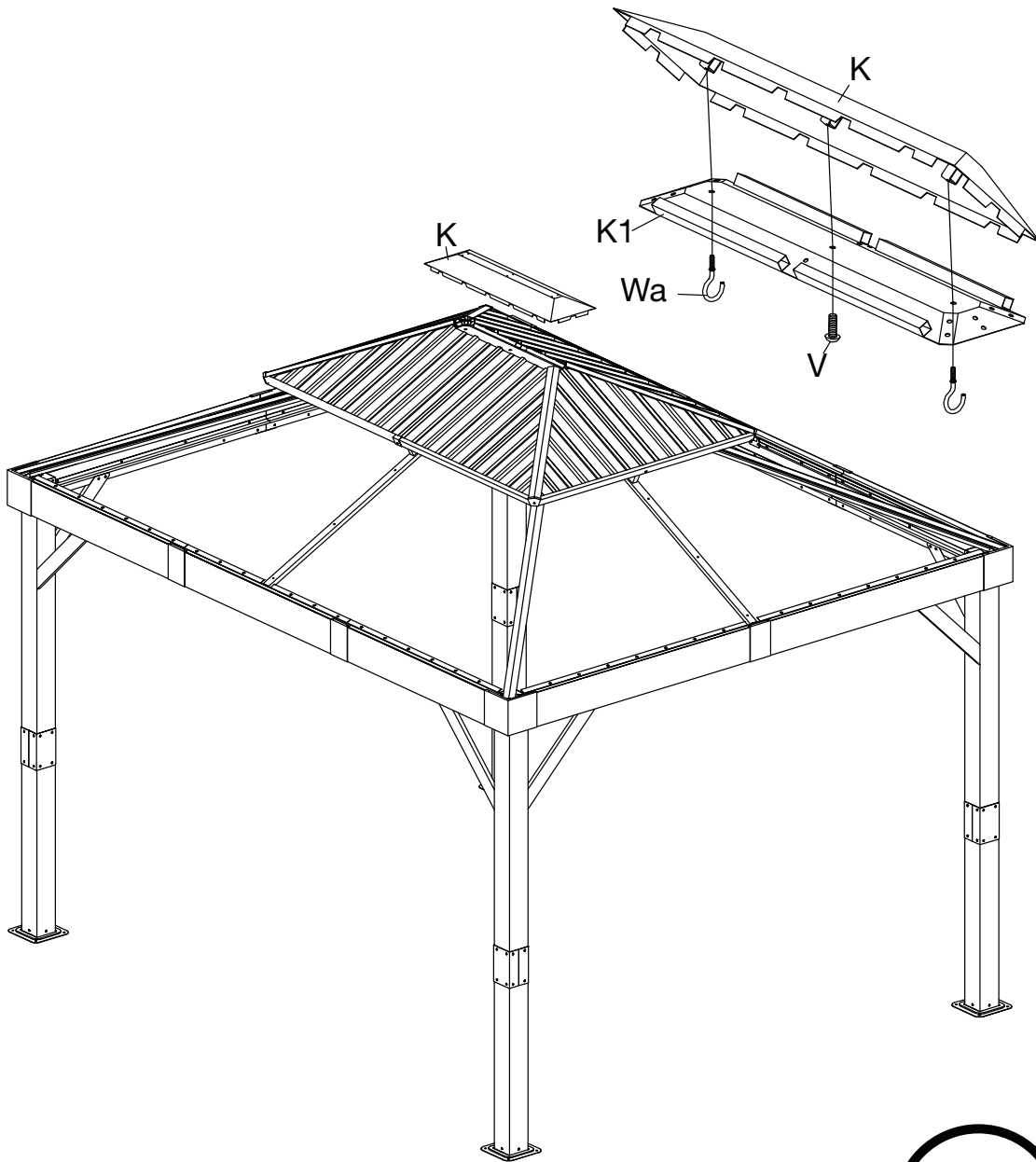

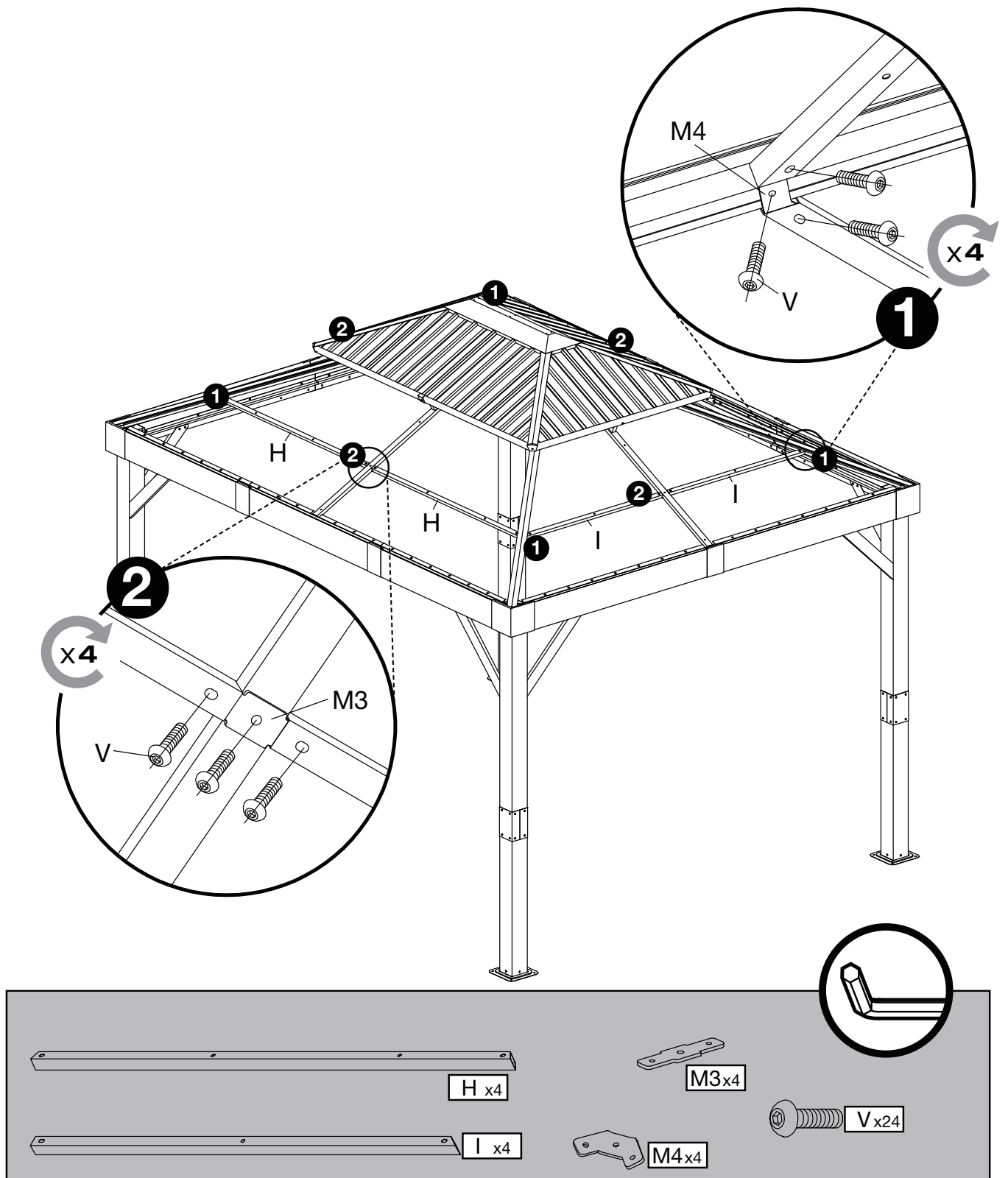

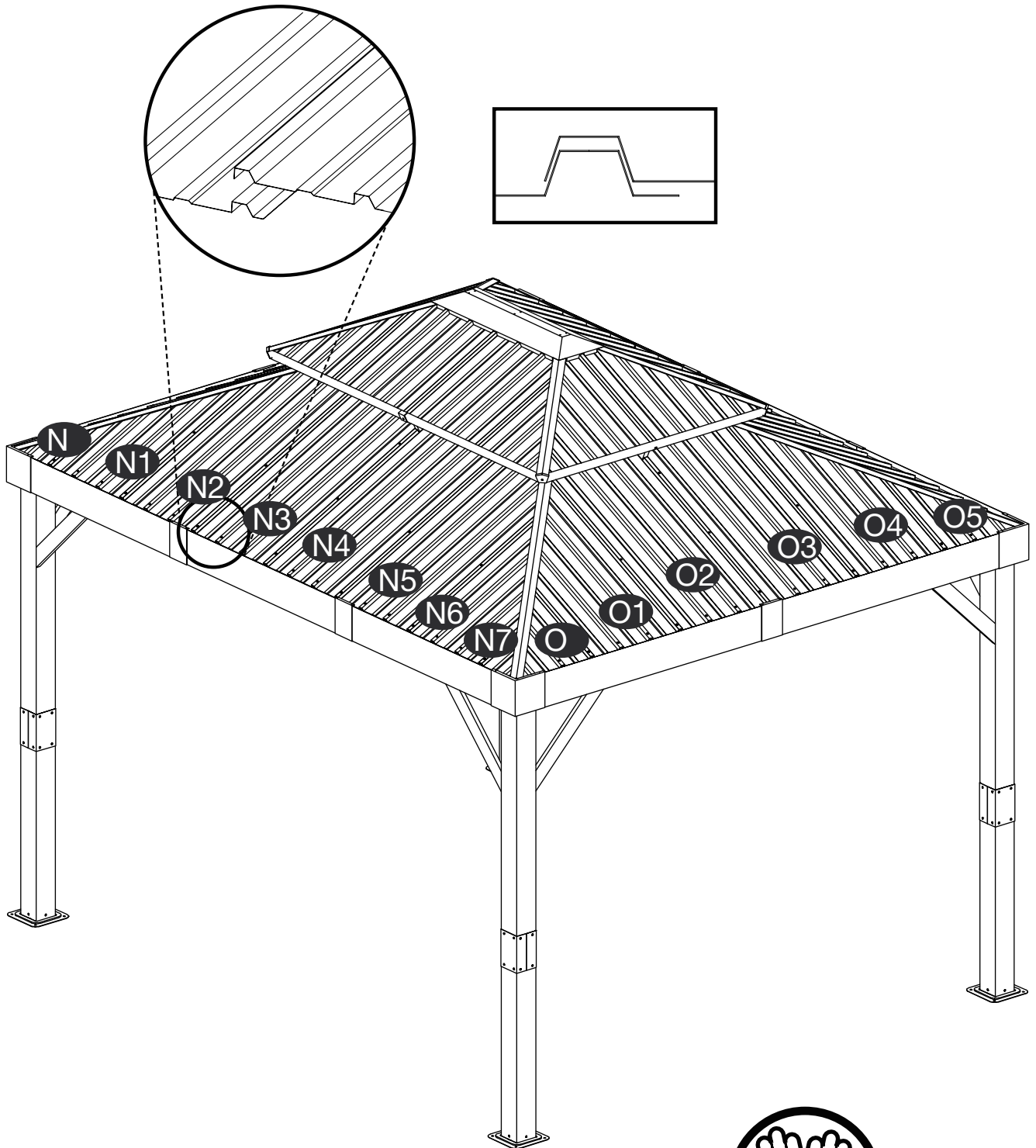

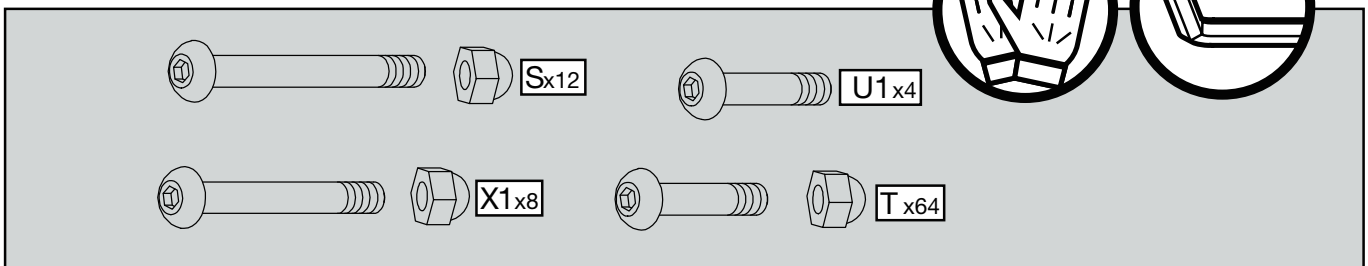
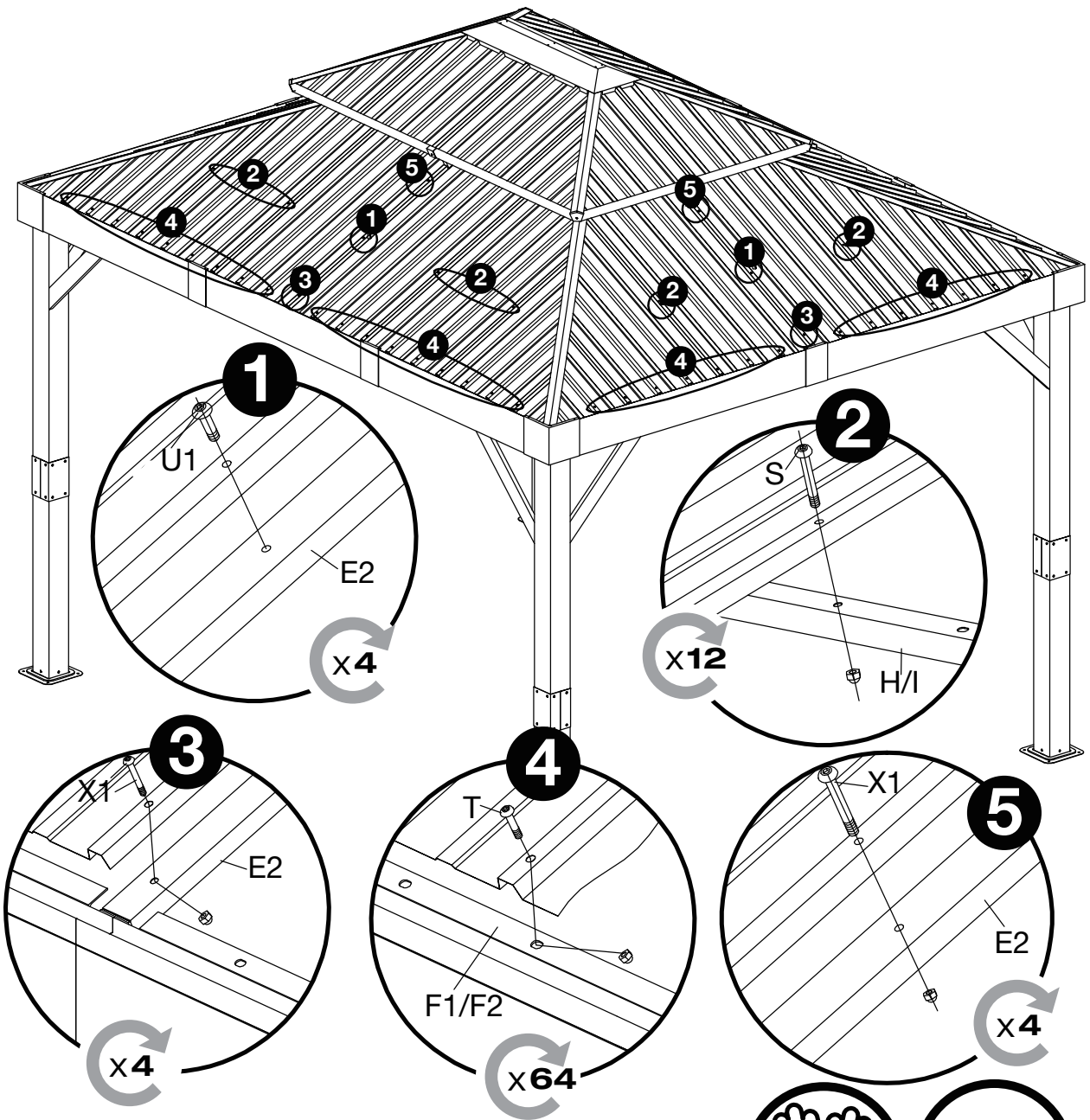

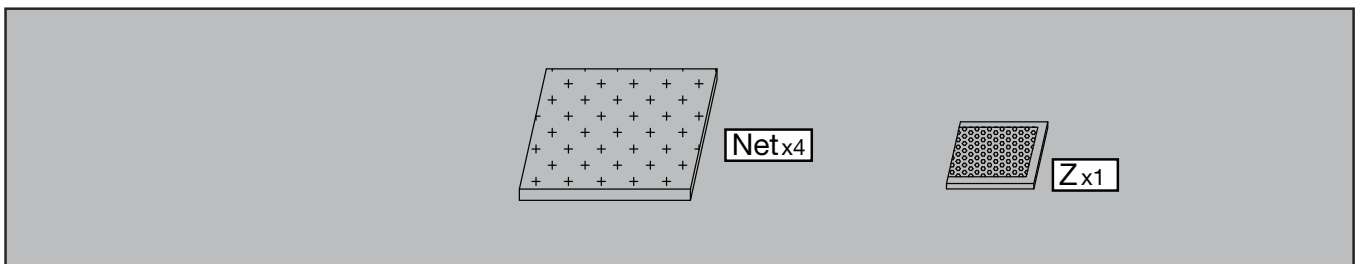
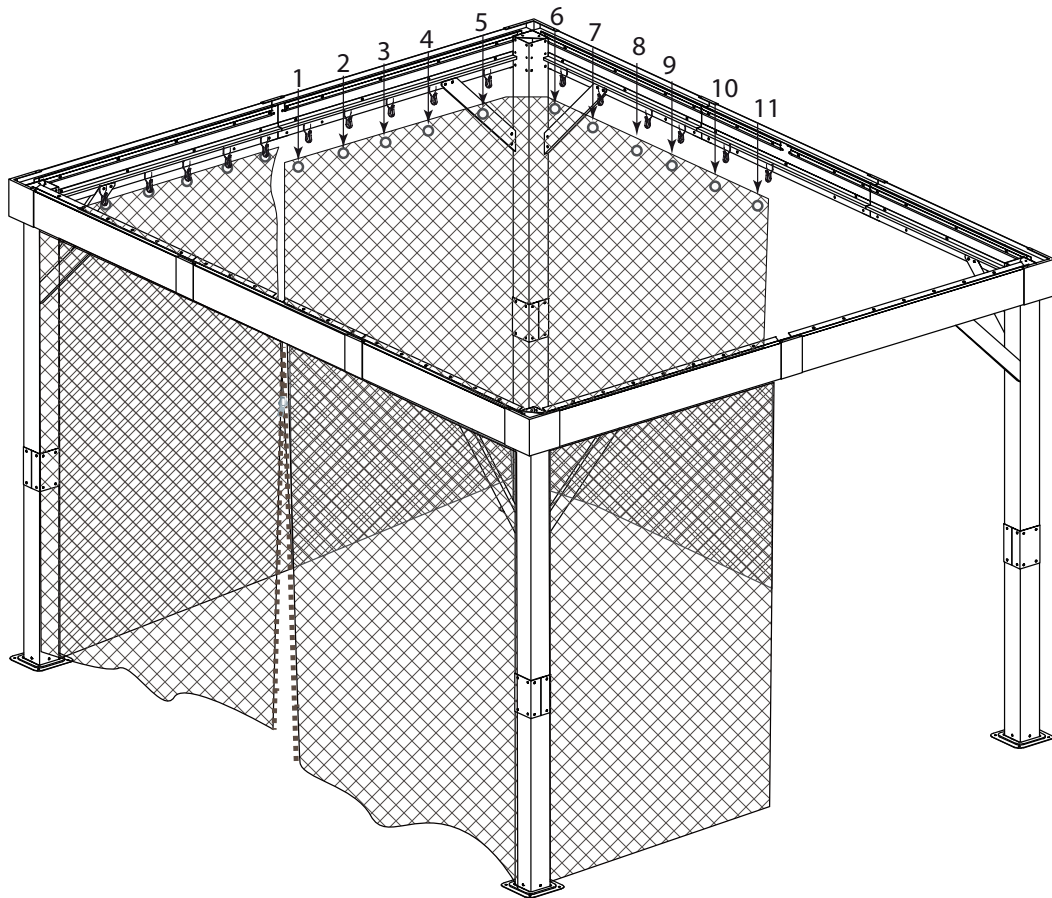
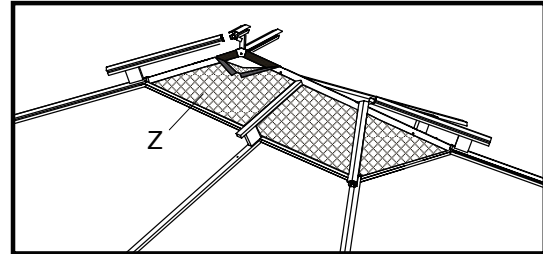
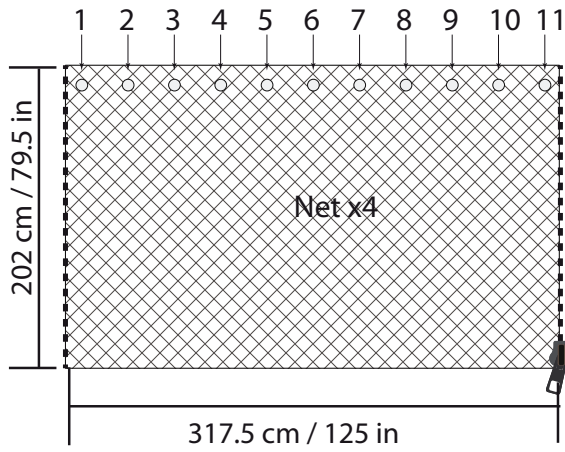

**Register • Enregistrer • Regístrate
가리키다 • Registrieren**



ShelterLogic.com/product-registration

SOJAG ■ |