

80-20101-40

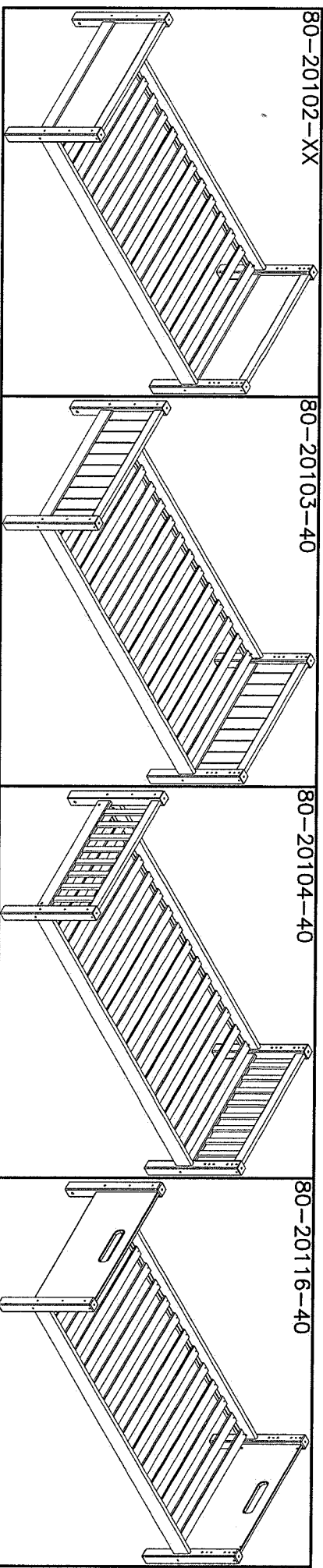

See assembly instruction in box no.
 Voir notice de montage dans la caisse no.
 Siehe Aufbauanleitung im Karton no.
 Zie voor de montage-instructie pakketnr.

Before assembling this product, please ensure that all the components supplied comply with the list on this page. All Screw-type fittings can be tightened with this tool.

Avant de commencer l'assemblage, veuillez contrôler si tous les objets indiqués sont présents. Tous les vis peuvent être serrés par cet outil.

Bevor Sie mit dem Aufbau beginnen kontrollieren Sie ob alle auf der Zeichnung angegebenen Teile vorhanden sind. Bitte verwenden Sie zur Montage einen Kreuzschraubzieher und den beiliegenden Innensechskantschlüssel.

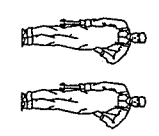
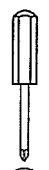

Ware-nr.
Part no.
Ref No

Stück.
Qty.
Qté.

Mess.
Dim.
Dim.

Siehe Bild-nr.
See picture no.
Image no

12-06306473-40 2 stck./pcs.	12-06306474-40 2 stck./pcs.	1305-19672-40 2 stck./pcs.	
<p>A</p> <p>3922-08018 8 stck./pcs. 647x63x63</p> <p>3930-10050 16 stck./pcs. 3909-70100 647x63x63</p> <p>3913-08110 8 stck./pcs. 3938-000081-2 16 stck./pcs. 3938-00010-2 20 stck./pcs. 3938-00016-2 4 stck./pcs. 4033-005 1 stck./pcs.</p> <p>Z1 M8/ø12x18 mm. Z2 ø10x50 mm. Z3 16 stck./pcs. Z4 ø7x100 mm. Z5 M8x110 mm. Z6 ø8 mm. Z7 ø10 mm. Z8 ø16 mm.</p>		<p>B</p> <p>647x63x63</p> <p>3901-40030 30 stck./pcs.</p> <p>1967x115x26</p>	<p>C</p> <p>4 stck./pcs. 3901-40030 30 stck./pcs.</p>

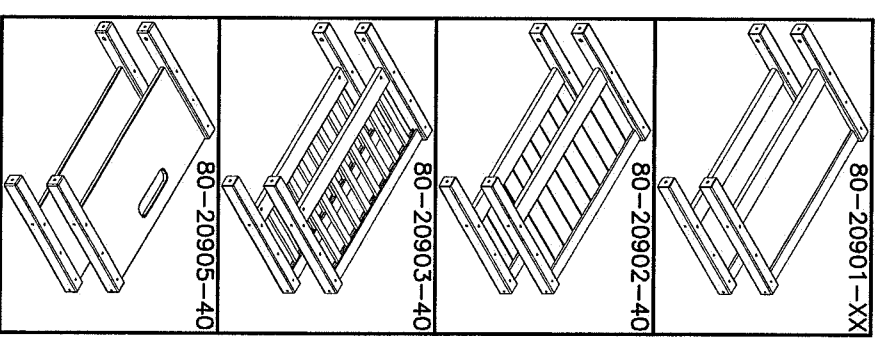

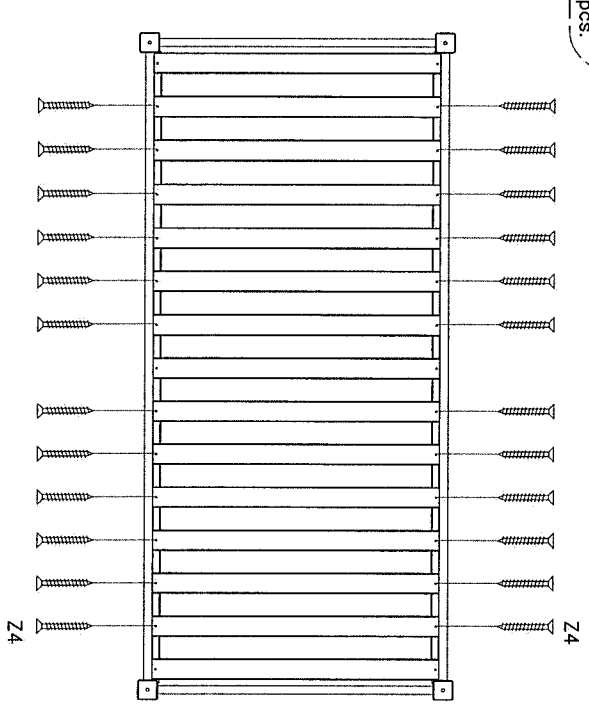
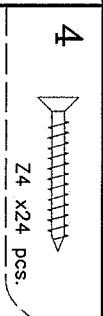
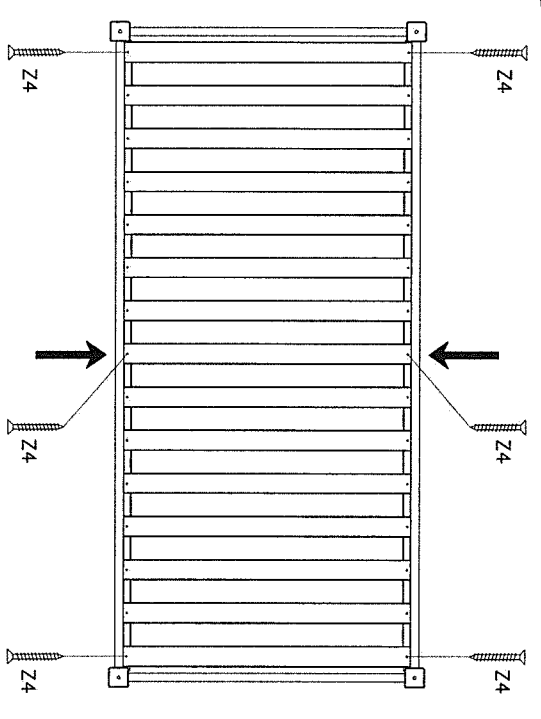
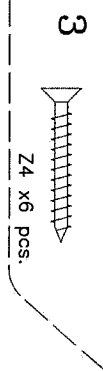
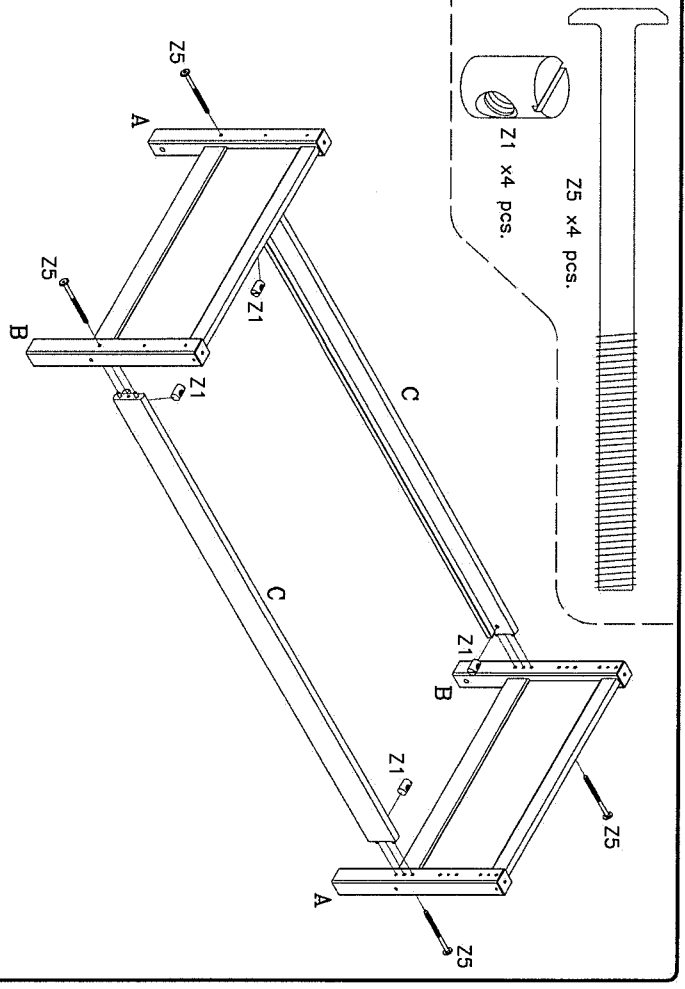
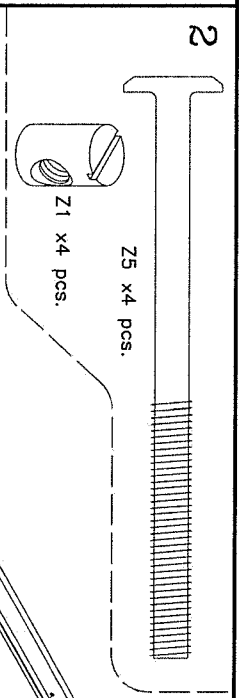
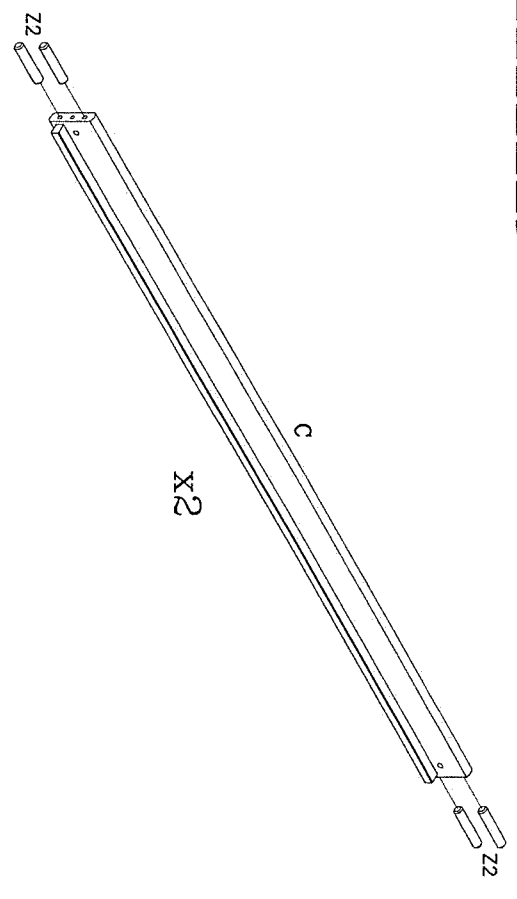
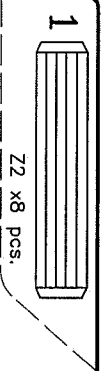

80-20905-40 White

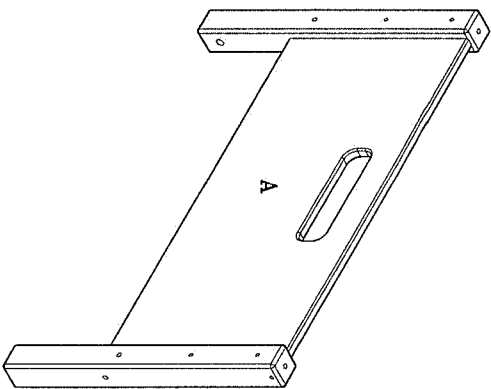

<p>Before assembling this bed, please ensure that all the parts supplied comply with the list page. All Screw-type fittings can be tightened with this tool.</p>	<p>Avant de commencer l'assemblage, veuillez contrôler si tous les objets indiqués sont présents, tous les vis peuvent être serrés par cet outil.</p>	<p>Bevor Sie mit dem Aufbau beginnen, kontrollieren Sie ob alle auf der Zeichnung angegebenen Teile vorhanden sind. Bitte sehen Sie zum Montieren einen Kreuzschraubenzieher und den hallogependen Innesschraubenschlüssel.</p>	<p>Waren-nr.: Part no. Réf. No.</p>	<p>Stück- Qty. Qté.</p>
<p>4301-2208631-40 2 stick/pcs.</p>	<p>3922-060181 4 stick/pcs. Z28 M6/Ø10x18mm 3913-06110 4 stick/pcs. 40x33-004 1 stick/pcs. 4 mm.</p>	<p>863x431x22 Z29 M6x110 mm.</p>	<p>Siehe Bild-nr. See picture no. Image no.</p>	<p>Mass Dim. Dim.</p>

Z1, Z2, Z5 Fittings in single / bunk bed box.
 Z1, Z2, Z5 Beschläge im Einzel- / Etagenbett Karton.
 Z1, Z2, Z5 Raccords en lit simple / lit superposé.
 Z1, Z2, Z5 Fittings in het enkelspel / stapelbed boxen.

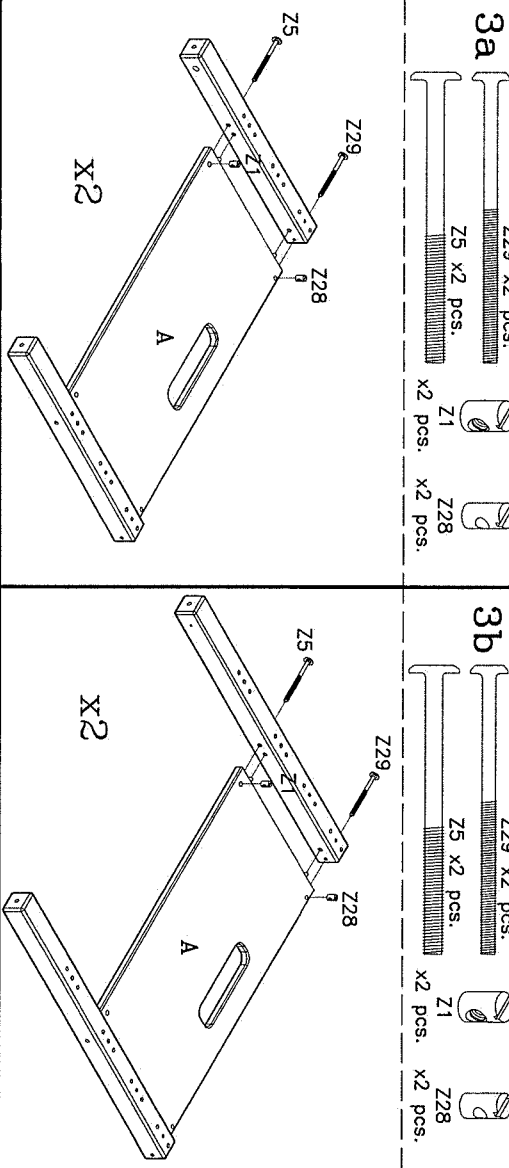
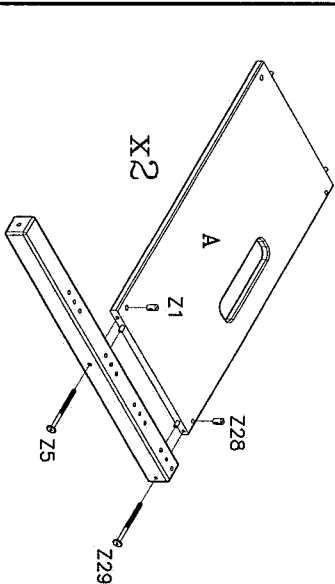
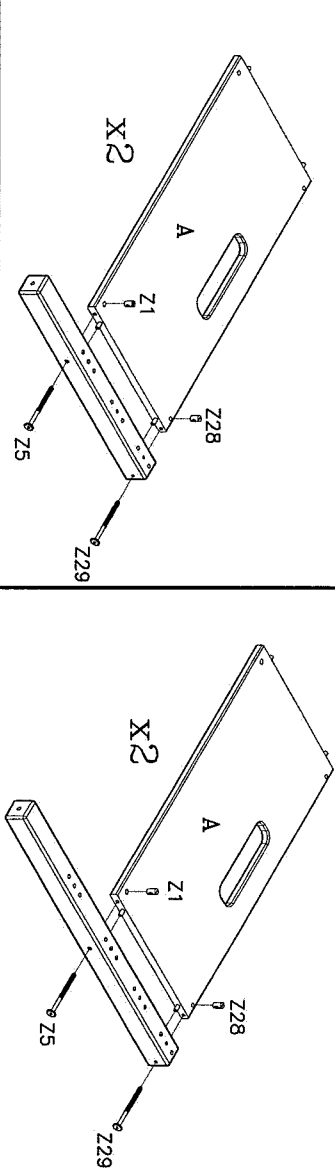
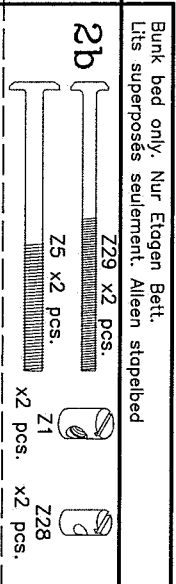
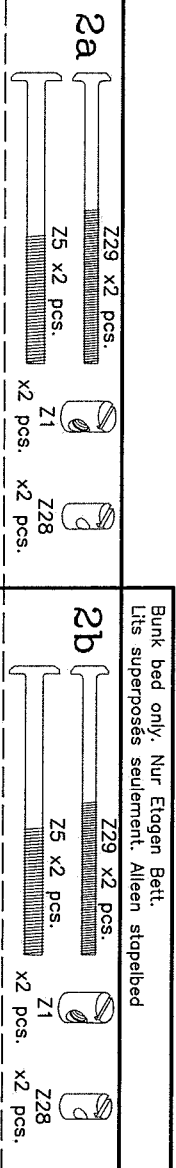
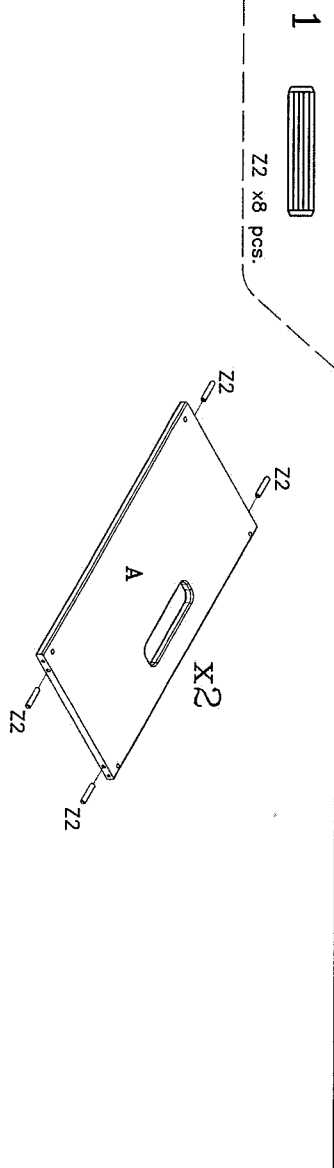

Bunk bed only. Nur Etagen Bett.
 Lits superposés seulement. Alleen stapelbed

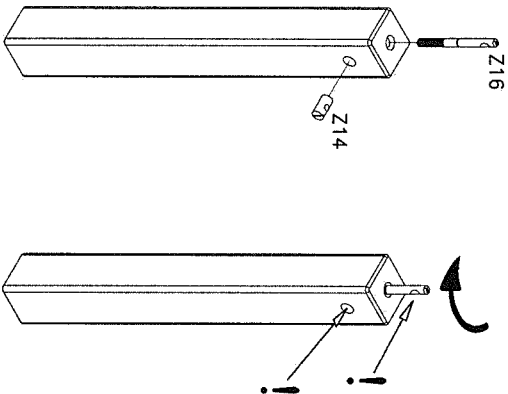
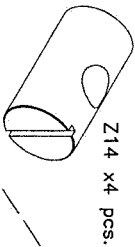
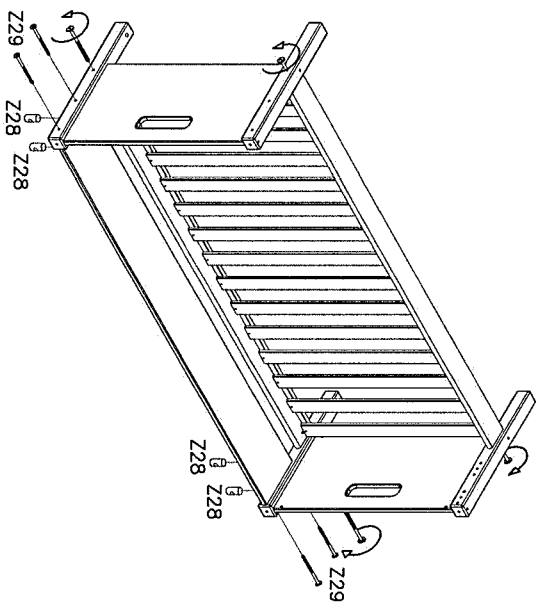
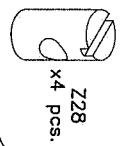
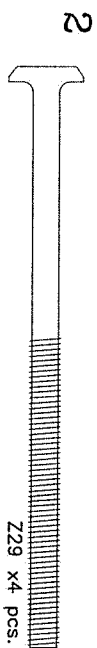
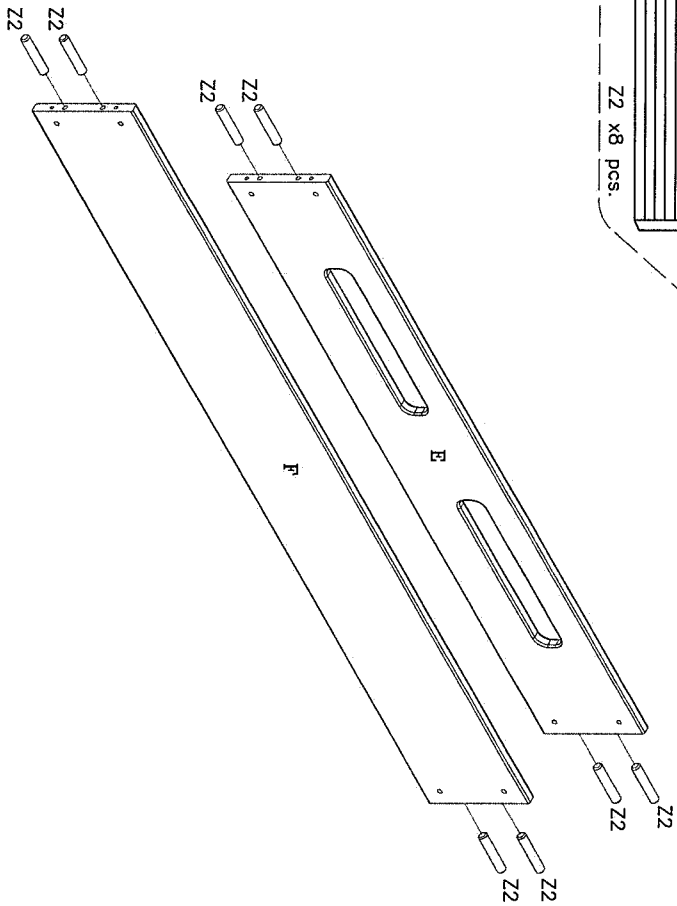
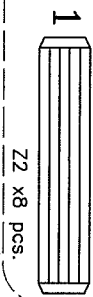

Screw the bolt Z16 into the leg, until the ring on the bolt is flush with the end of the leg.

Schroef de bout Z16 in de poot, tot de ringmarkering op de bout gelijkvakt met de bovenzijde van de poot.

Der Verbindungsbolzen Z16 wird eingeschraubt, bis der markierte Ring mit der Oberkante des Pfostens bündig ist.

Visser le goujon dans le pied jusqu'à ce que l'anneau gravé soit à fleur avec le bois.

4

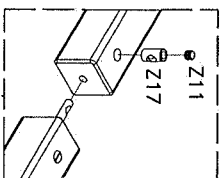
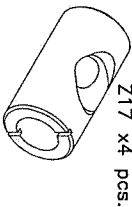

If the leg is loose after assembly, loosen the screw Z11 slightly, until the lower leg can be turned 1 time around clockwise. Then tighten the Z11 screw again.

Indien de poot na montage niet vast genoeg zit, dient u schroef Z11 iets los te draaien, tot de onderste poot 1 keer rechtsom gestrookd kan worden. Daarna kunt u schroef Z11 weer vastschroeven.

Wenn die Pfosten nicht fest genug angezogen sind, muss die Schraube Z11 leicht gelöst werden, bis der untere Pfosten 1 Mal rechts herum gedreht werden kann. Dann muss die Schraube Z11 wieder gespannt werden.

Si les deux montants de pied ne sont pas suffisamment serrés, il convient de desserrer légèrement la vis Z11, jusqu'à pouvoir tourner la partie inférieure du pied 1 fois dans le sens des aiguilles d'une montre. Ensuite reserrer la vis Z11.

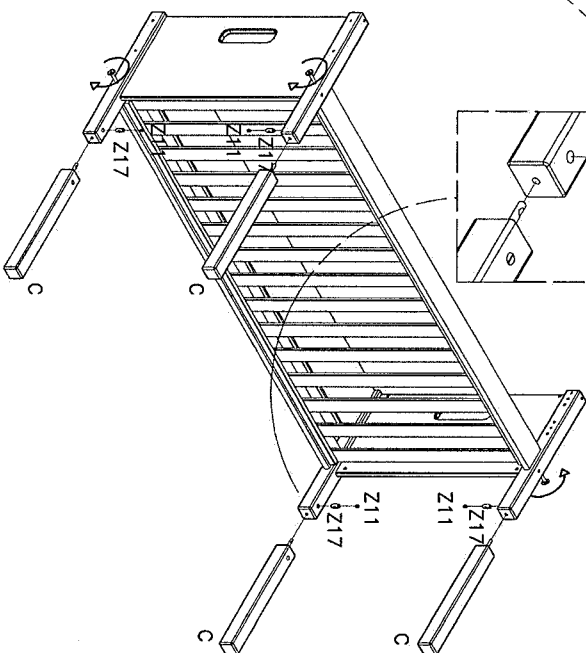

5

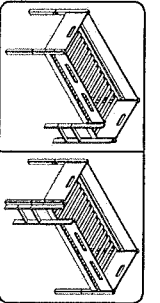
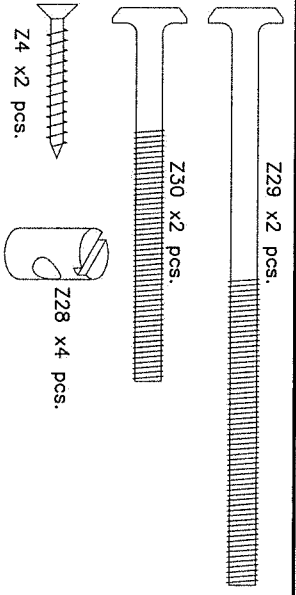

Dk: Max. madrashøjde
 D: Max. Höhe der Matratze
 GB: Max. height of mattress
 F: Hauteur max. du matelas
 I: Altezza max. materasso
 E: Altura del colchón máximo
 NL: Maximale matrashoogte
 CN: 最大床垫之高度

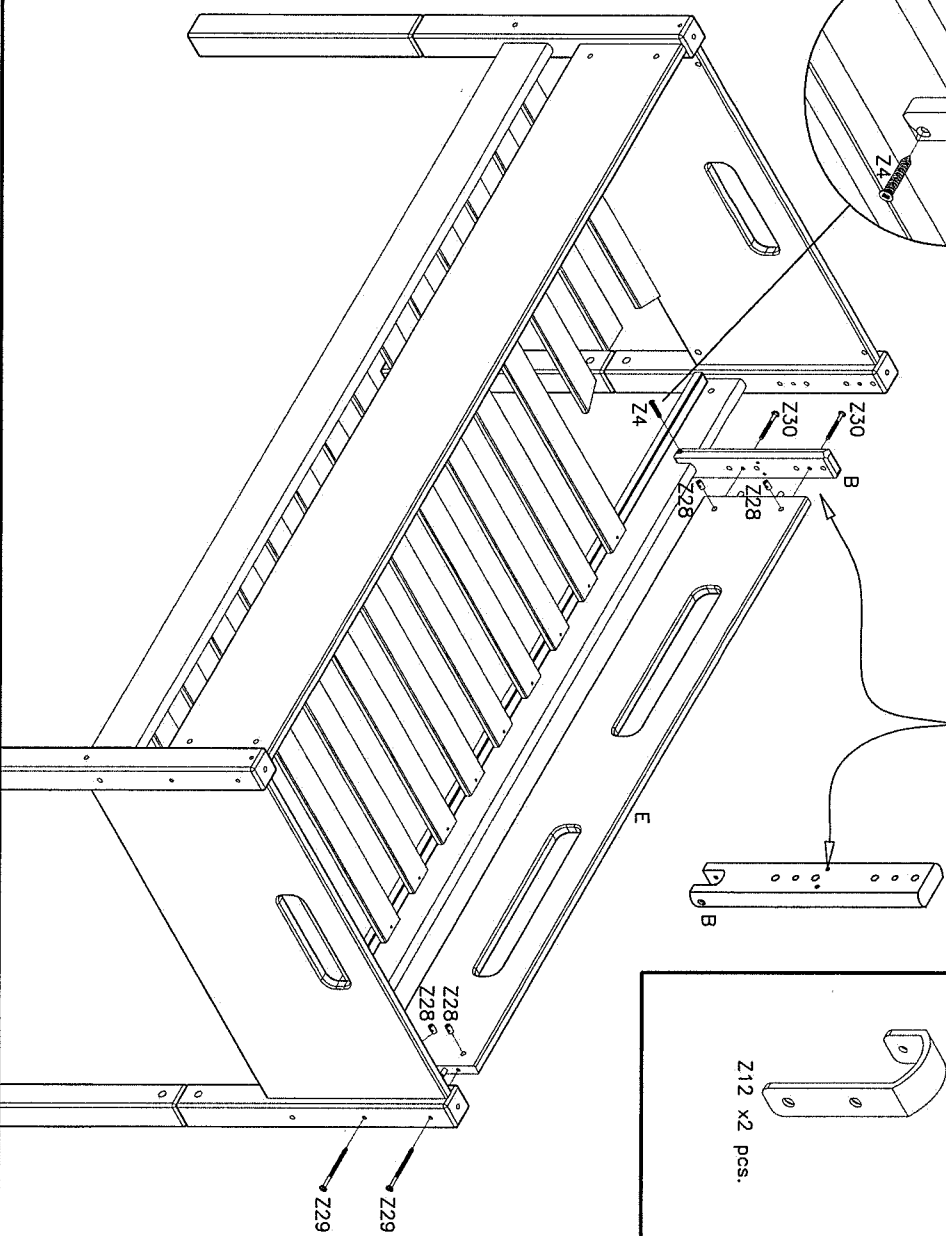
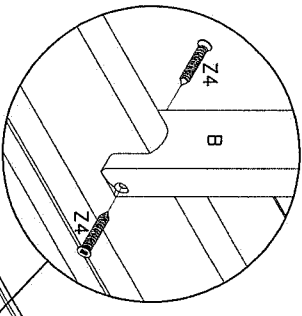

6

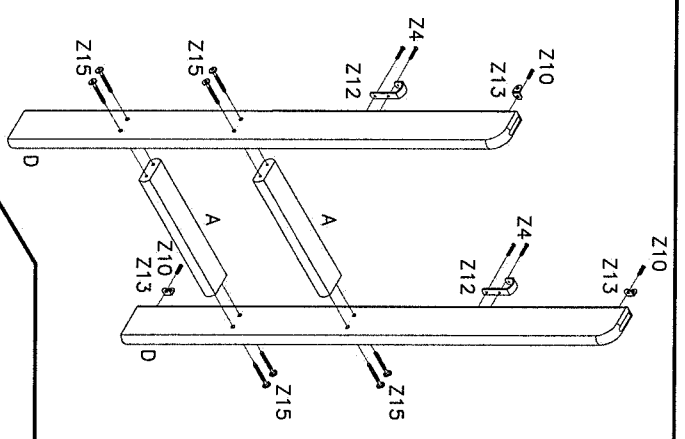
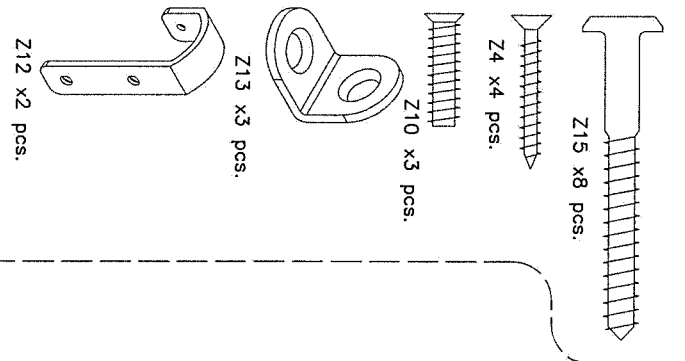

7

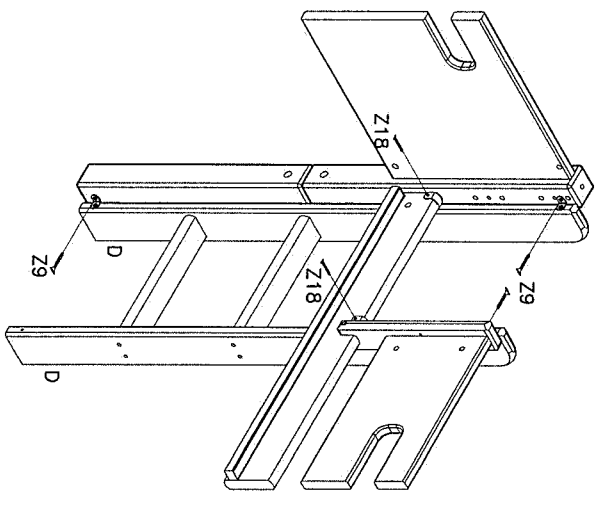
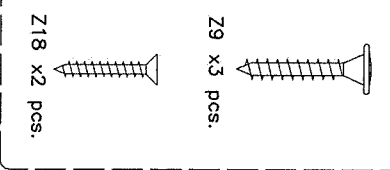

82-70146-40

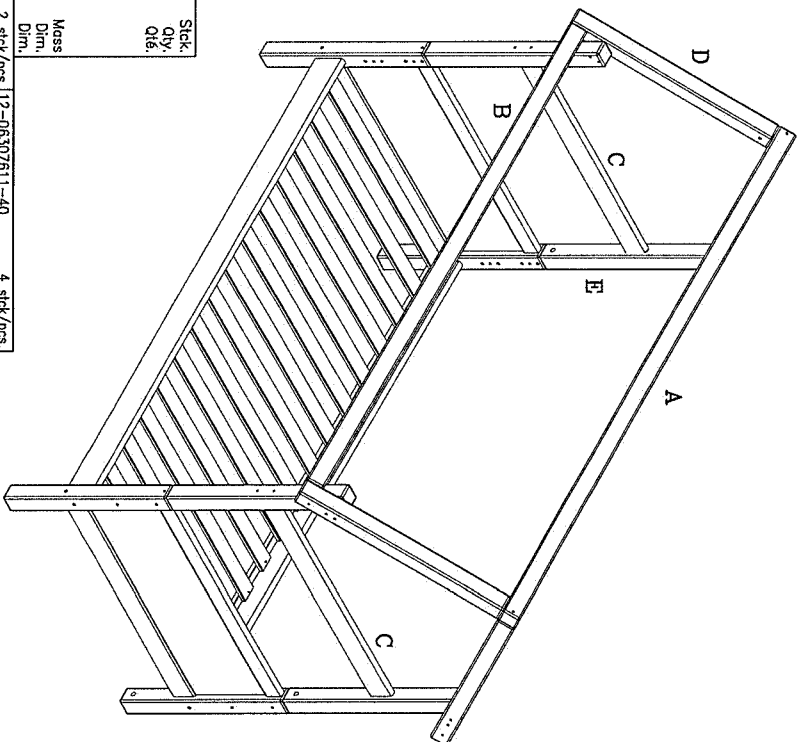

Before assembling this product, please ensure that all the components supplied comply with the list on this page. All Screw-type fittings can be tightened with this tool.

Avant de commencer l'assemblage, veuillez contrôler si tous les objets indiqués sont présents. Tous les vis peuvent être serrés par cet outil.

Bevor Sie mit dem Aufbau beginnen, kontrollieren Sie ob alle auf der Zeichnung angegebenen Teile vorhanden sind. Bitte verwenden Sie zur Montage einen Kreuzschraub-Zeher und den beiliegenden Innebeschraubenschlüssel.

12-0632191-40

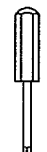

1 stick/pcs:

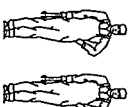

12-06320931-40

Ware-nr.
Part no.
Réf No

2 stick/pcs:

12-06307611-40

Mass
Dimn.
Dimn.

4 stick/pcs:

80-20101-40

See assembly instruction in box no. 80-20101-40

Voir notice de montage dans la caisse no. 80-20101-40

Zie voor de montage-instructie pakkeotr. 80-20101-40

<p>A 2219x63x63 3930-10050 4 stick/pcs. 3909-70100</p>	<p>B 2093x63x63 3933-15028 4 stick/pcs.</p>	<p>C 863x99,26 3930-08040 4 stick/pcs. 3934-10080</p>	<p>D 761x63x63 12-06307001-40 4 stick/pcs.</p>
<p>Z2 ø10x50 mm. 3938-00016-2 4 stick/pcs.</p>	<p>Z3 ø7x100 mm. 3913-06120 16 stick/pcs.</p>	<p>Z11 M10x12 mm. 3922-06020 4 stick/pcs. 3922-06048 4 stick/pcs.</p>	<p>Z19 ø15x28 mm. 3923-06015 8 stick/pcs. 3923-06015 8 stick/pcs.</p>
<p>Z8 ø16 mm. 3913-06120 16 stick/pcs.</p>	<p>Z28 M6x120 mm. 3922-06020 4 stick/pcs. 3922-06048 4 stick/pcs.</p>	<p>Z29 M6/ø10x20 mm. 3923-06015 8 stick/pcs.</p>	<p>Z30 M6/ø10x48 mm. 3923-06015 8 stick/pcs. 3923-06015 8 stick/pcs.</p>
<p>Z31 ø8/ø6x15 mm. 4033-005 1 stick/pcs. 4033-004 2 stick/pcs.</p>	<p>Z21 ø8x40 mm. 4033-005 1 stick/pcs. 4033-004 2 stick/pcs.</p>	<p>Z31 ø8/ø6x15 mm. 4033-005 1 stick/pcs. 4033-004 2 stick/pcs.</p>	<p>Z31 ø8/ø6x15 mm. 4033-005 1 stick/pcs. 4033-004 2 stick/pcs.</p>

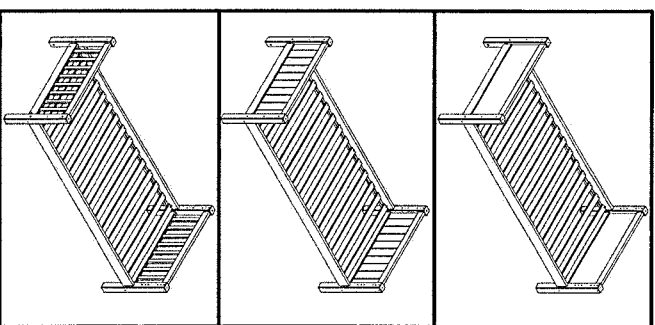

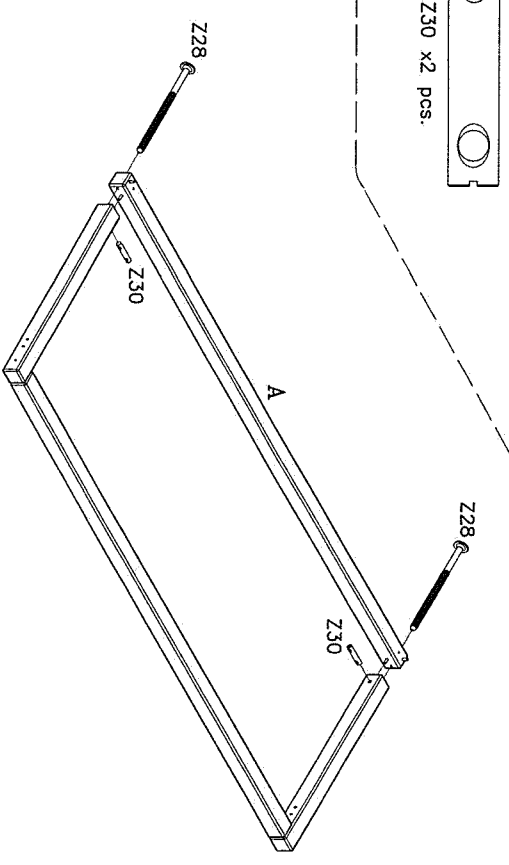
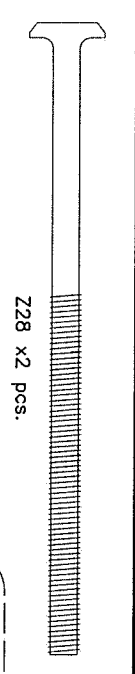
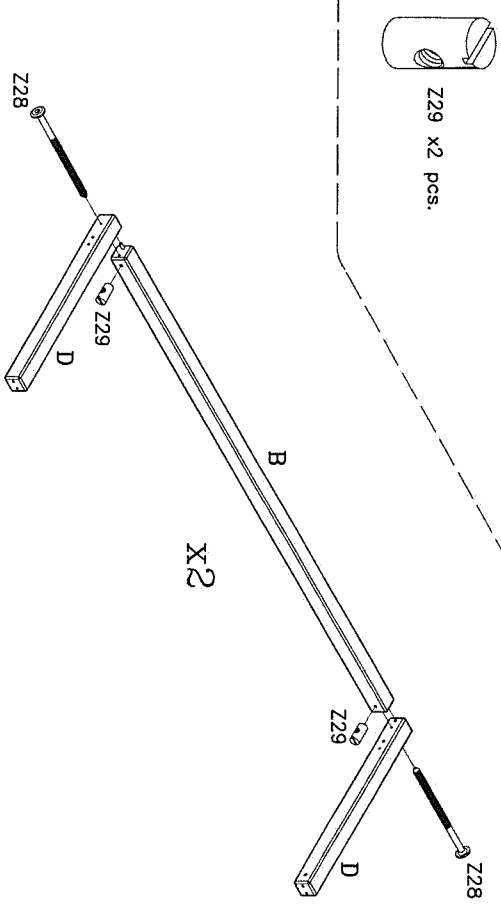
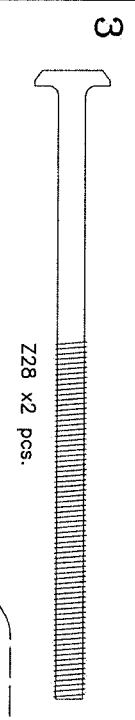
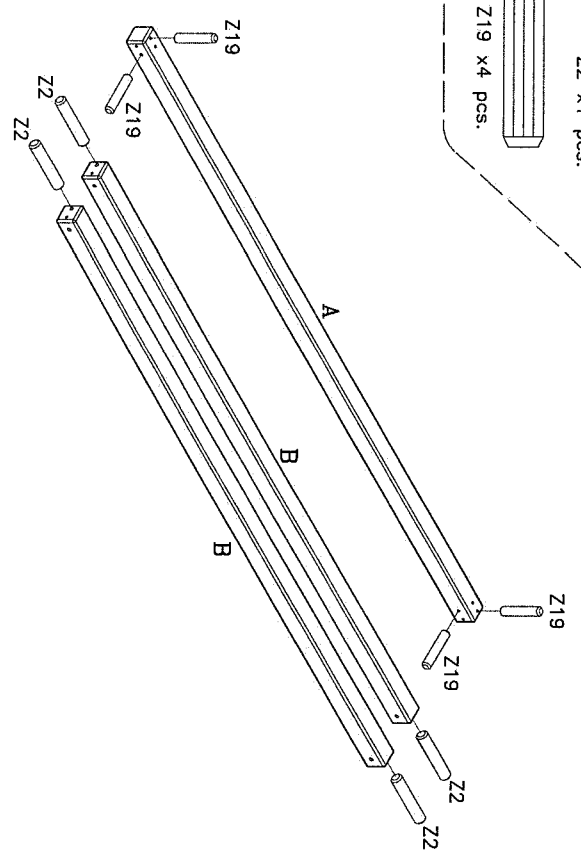
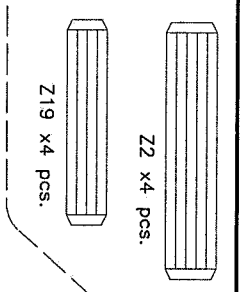
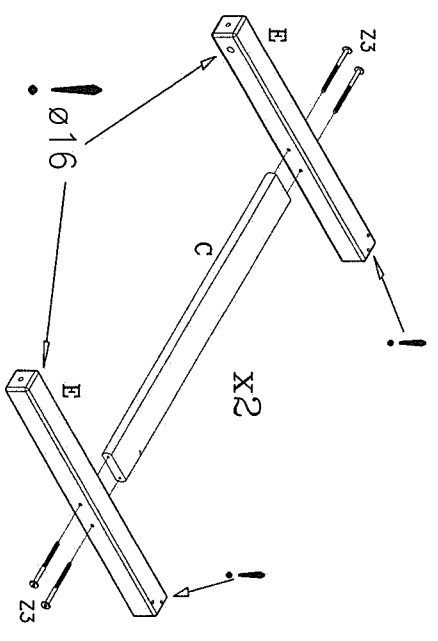
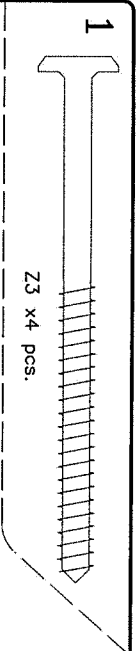

5

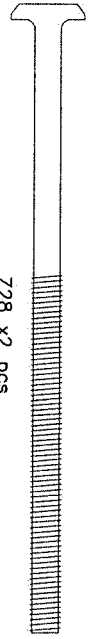

Z28 x2 pcs.



Z30 x2 pcs.

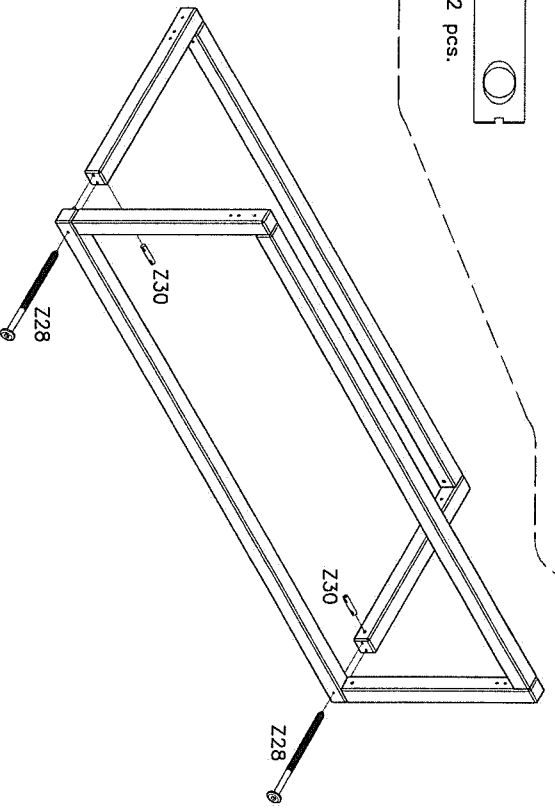

6

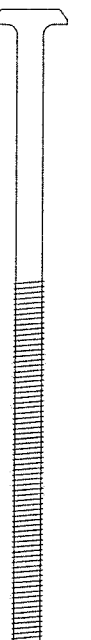

Z28 x8 pcs.

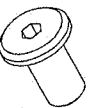

Z31 x8 pcs.

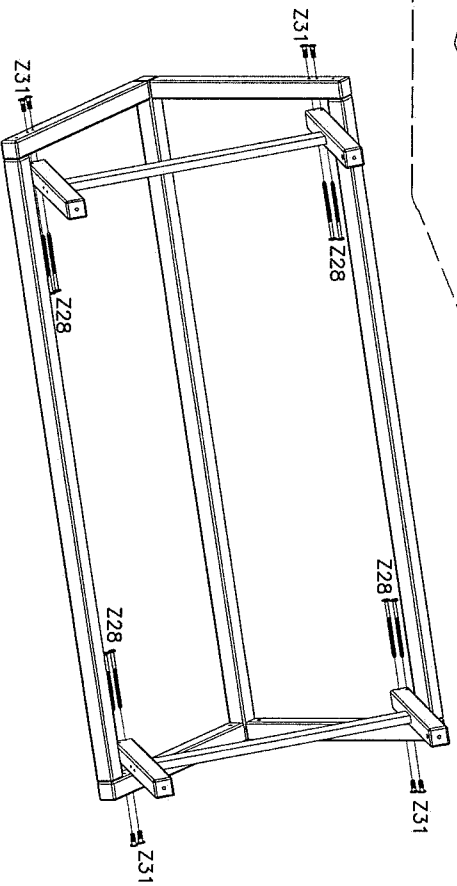

7



Z21 x4 pcs.

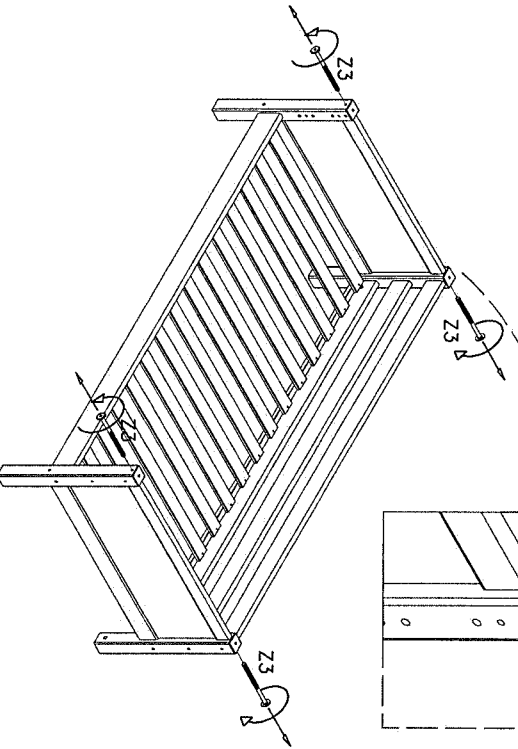

8



Z11 x4 pcs.

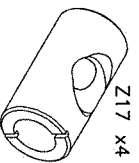

Z17 x4 pcs.

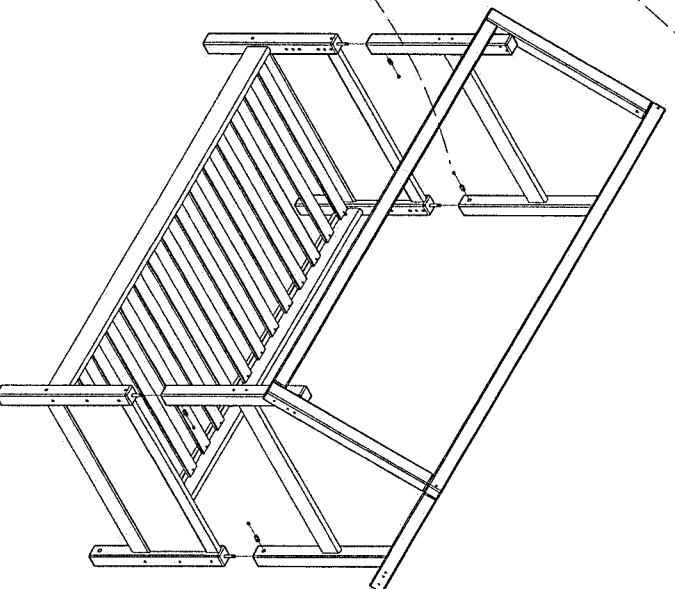
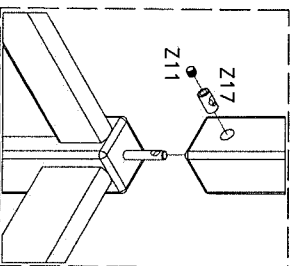

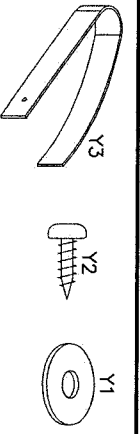

9

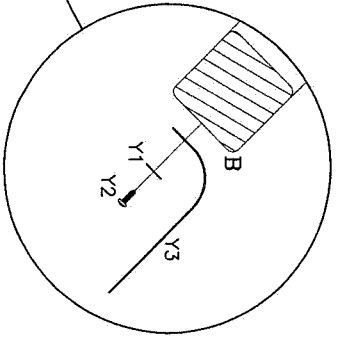
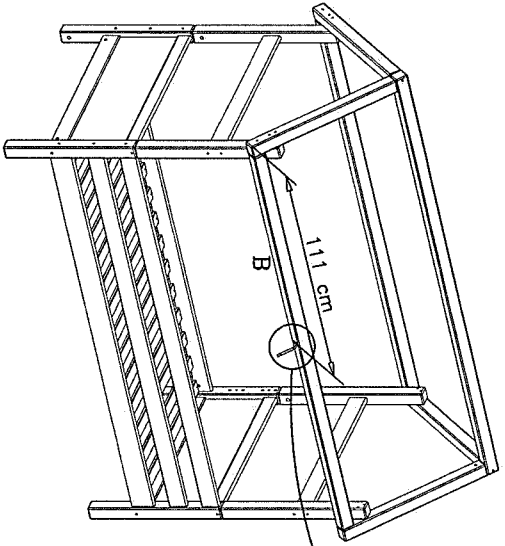

10

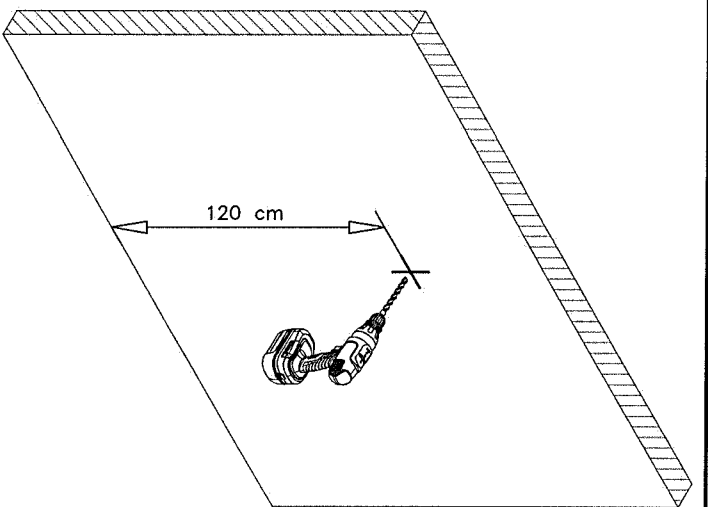

11

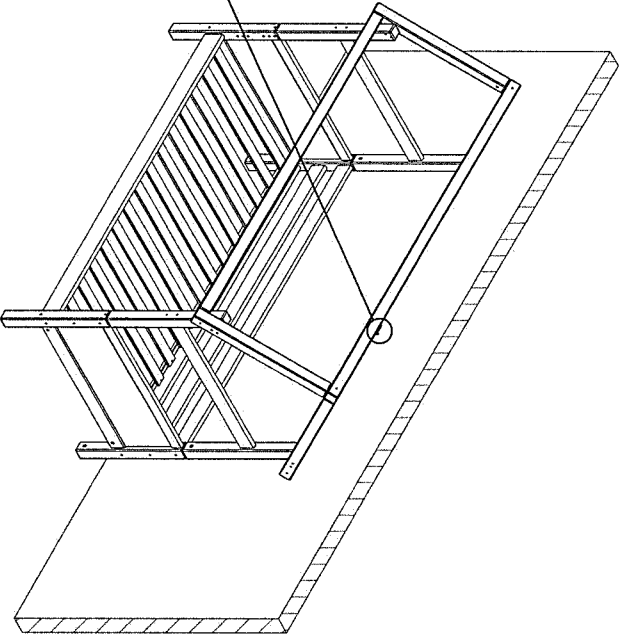
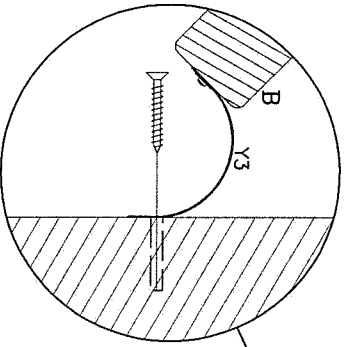

82-70193-40

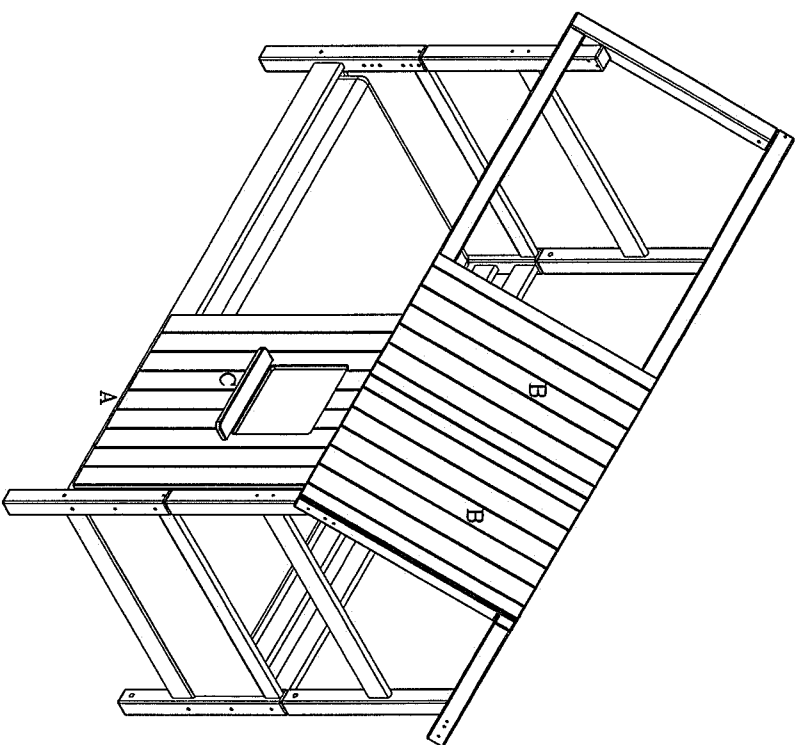

Before assembling this product, please ensure that all the components supplied comply with the list on this page. All Screw-type fittings can be tightened with this tool.

Avant de commencer l'assemblage, veuillez contrôler si tous les objets indiqués sont présents. Tous les vis peuvent être serrés par cet outil.

Bevor Sie mit dem Aufbau beginnen, kontrollieren Sie ob alle auf der Zeichnung angegebenen Teile vorhanden sind. Bitte verwenden Sie zur Montage einen Kreuzschraub-Zeher und den beiliegenden Innensechskantschlüssel.

Ware-nr.
Part no.

Stück.
Qty.
Q.té.

4301-1910031-40

1 stick/pcs 4301-1609241-40

2 stick/pcs 12-01903701-40

1 stick/pcs.

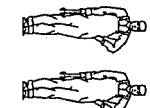
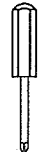

Stiehe Bild-nr.
See picture no.
Image no

Mass
Dim.
Dim.

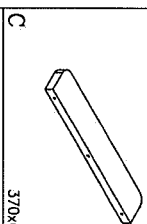
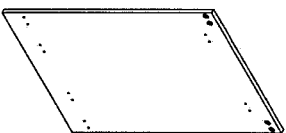
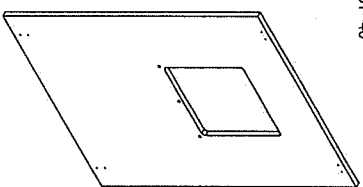

A

B

C

1003x785x19 824x55x16 370x65x19

3901-30020 2 stick/pcs 3901-35015 4 stick/pcs

3908-70050 3 stick/pcs

3903-40015 24 stick/pcs 3907-58011 16 stick/pcs

4016-003 8 stick/pcs 4007-014 2 stick/pcs

4033-004 1 stick/pcs.

Z1 30x20 mm, Z2 3,5x15 mm, Z3 4,0x15 mm, Z4 5,8x11 mm, Z5 4 mm.

Z6 7,0x50 mm, Z7 50x41 mm, Z8 15,5x3 mm, Z9 42x50 & 20x58 mm.

Z1 30x20 mm, Z2 3,5x15 mm, Z3 4,0x15 mm, Z4 5,8x11 mm, Z5 4 mm.

Z6 7,0x50 mm, Z7 50x41 mm, Z8 15,5x3 mm, Z9 42x50 & 20x58 mm.

Z1 30x20 mm, Z2 3,5x15 mm, Z3 4,0x15 mm, Z4 5,8x11 mm, Z5 4 mm.

Z6 7,0x50 mm, Z7 50x41 mm, Z8 15,5x3 mm, Z9 42x50 & 20x58 mm.

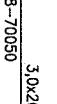



Ref.no. 44-01899

B1

Stand: 010922

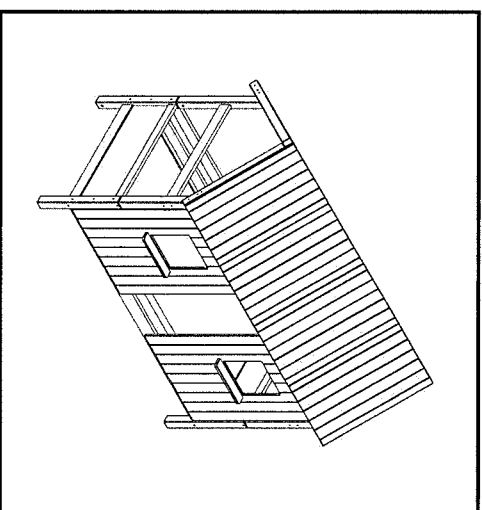
Page 1-2

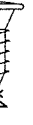

- 1** Z2  x4 Z3  x4

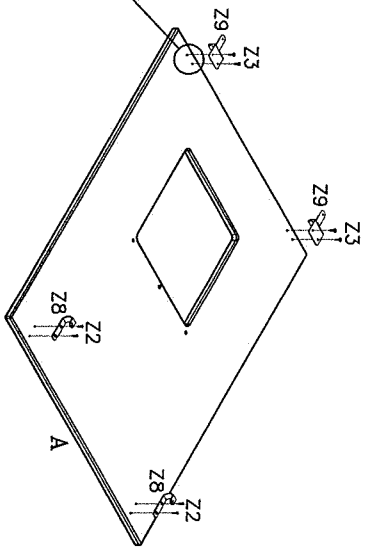
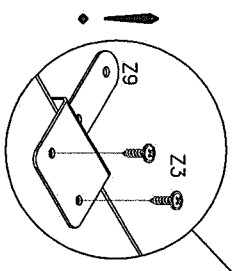
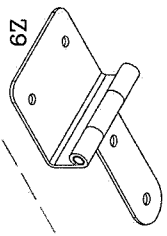
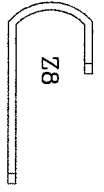

- 2** Z4  x16

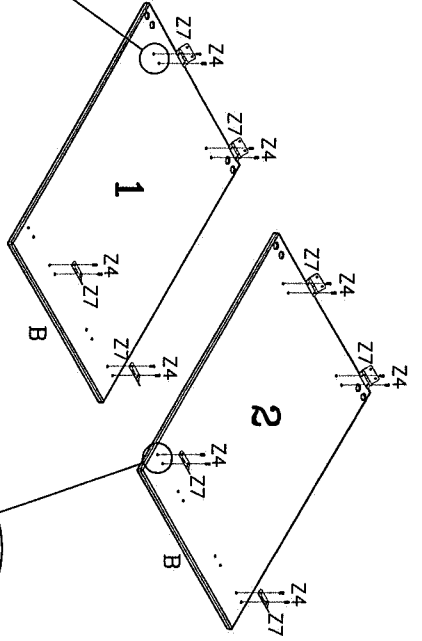
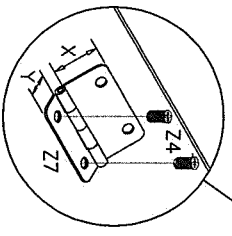
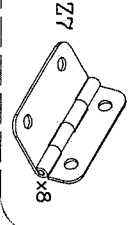

- 3** Z1  x2

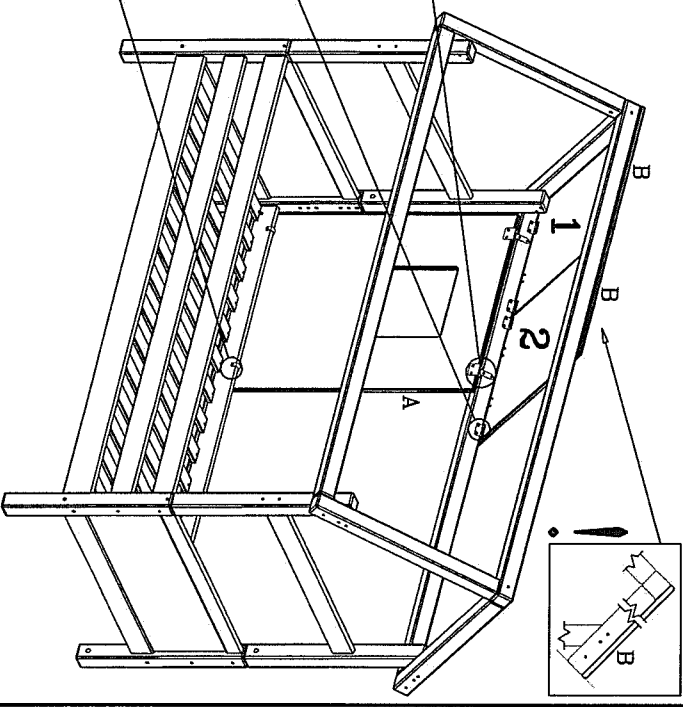
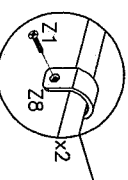
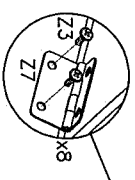
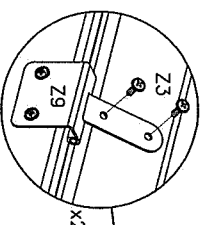
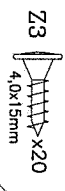

- 4** Z6  x3

