

Art. Nr. 4328 8057, 9393 5625

VAR1

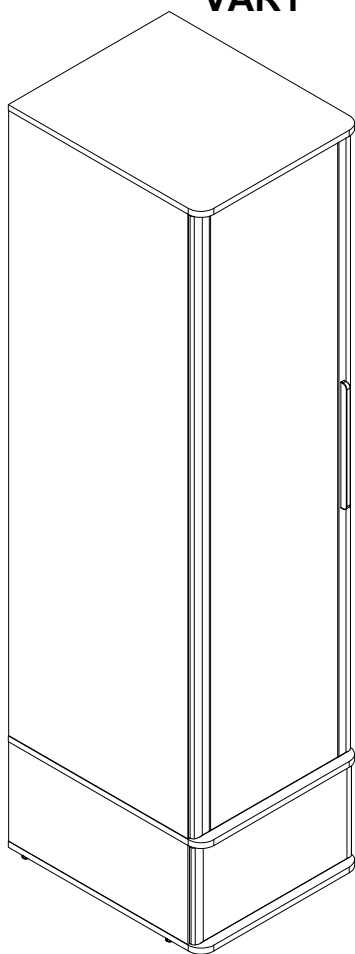

VAR2

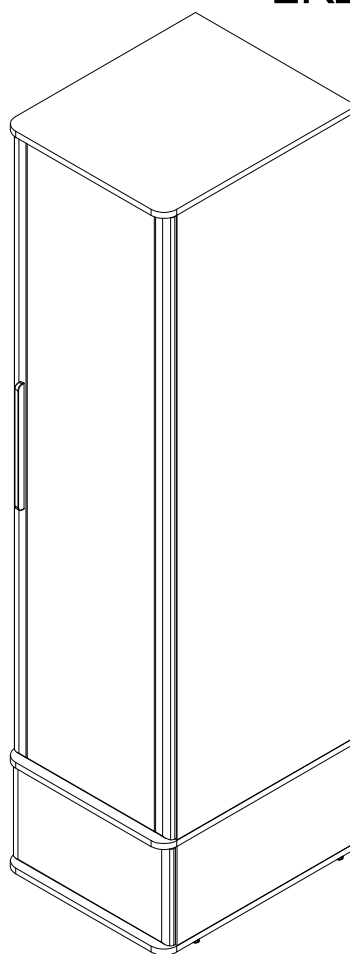

LKZ 41164



(D) Montageanleitung

(FR) Notice de montage

(NL) Handleiding voor de montage

(CZ) Montážní návod

(HU) Szerelési útmutató

(TR) Montaj talimati

(GB) Assembly instructions

(IT) Istruzioni di montaggio

(PL) Instrukcja montazu

(SK) Návod na montáž

(RO) Instruktiuni de montaj

(RU) Инструкция по монтажу

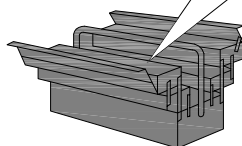
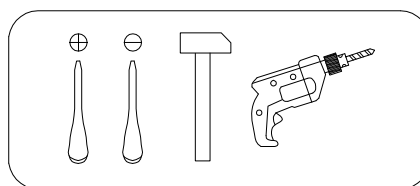
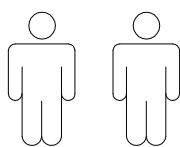

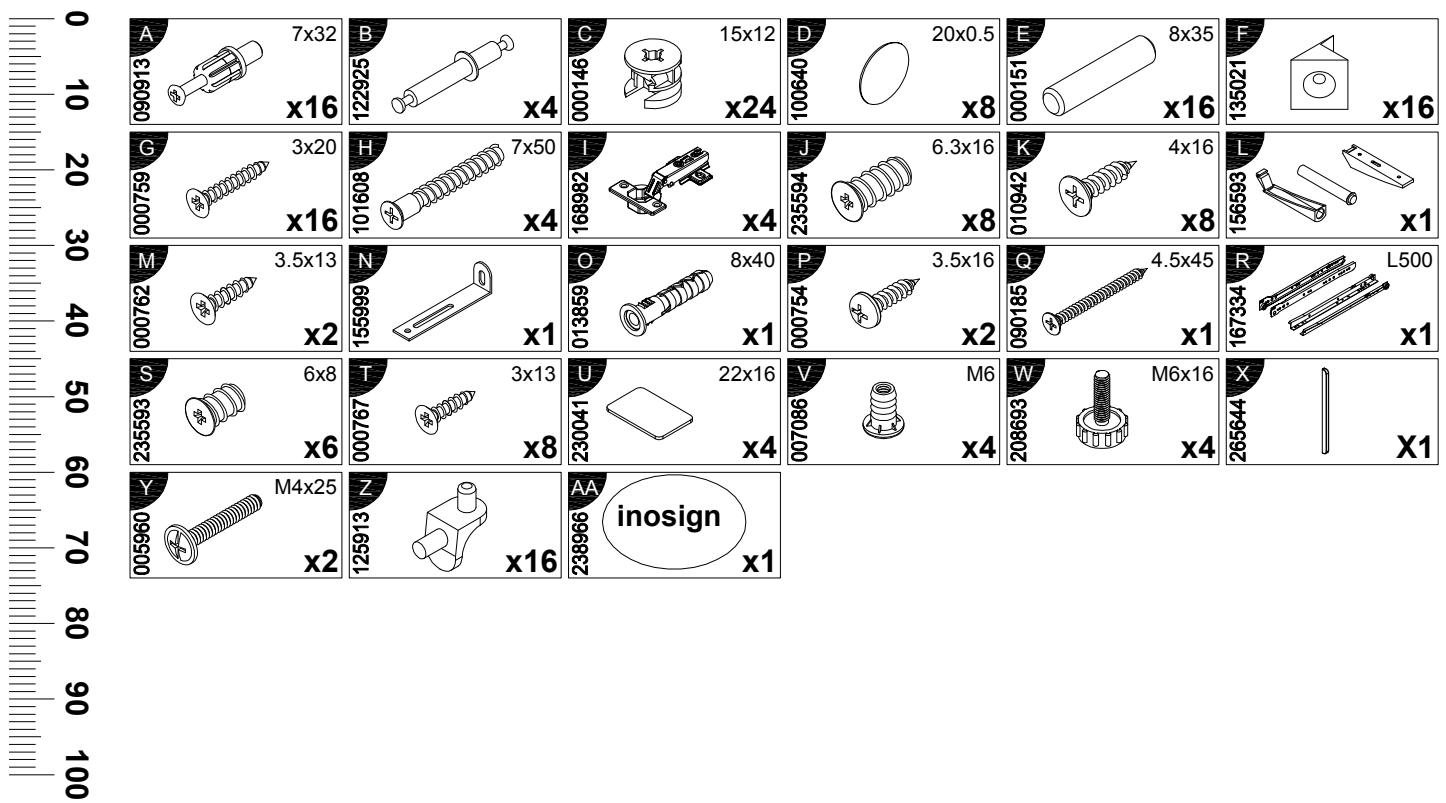

N	Size/MaB (mm)	Qty	✓	N	Size/MaB (mm)	Qty	✓
1	1688x559x16	1		9	502x601x16	1	
2	1688x559x16	1		10	502x601x16	1	
3	269x559x16	2		11	502x601x16	1	
4	500x140x16	1		12	1680x496x19	1	
5	500x140x16	1		13	468x535x16	1	
6	445x140x16	1		14	468x535x16	3	
7	496x261x19	1		15	280x478x3	1	
8	468x200x16	1		16	1698x478x3	1	
				17	421x510x3	1	

Service - Dienstverlening - Serwis - Servis - Сервисная служба

Name - Naam - Nazwa - Isim - Название



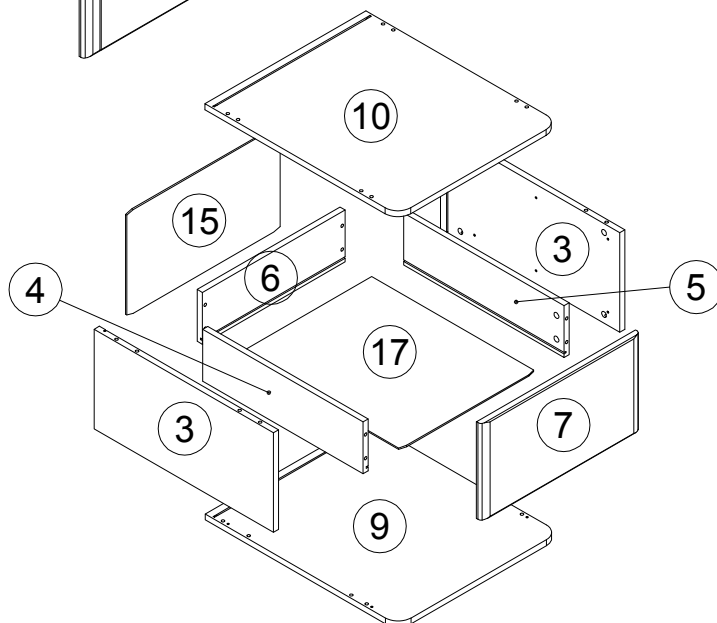
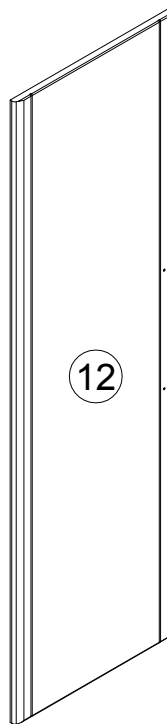
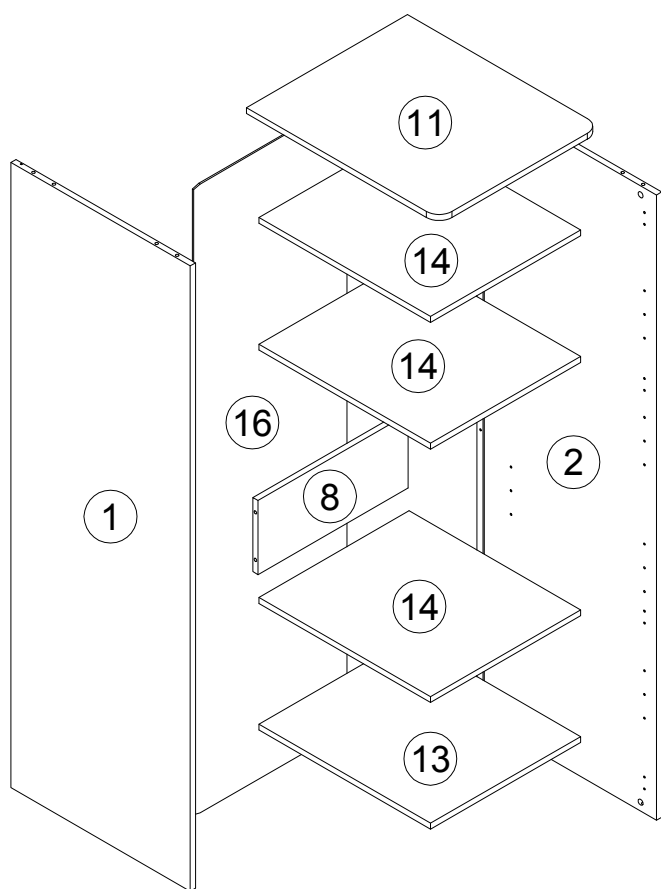
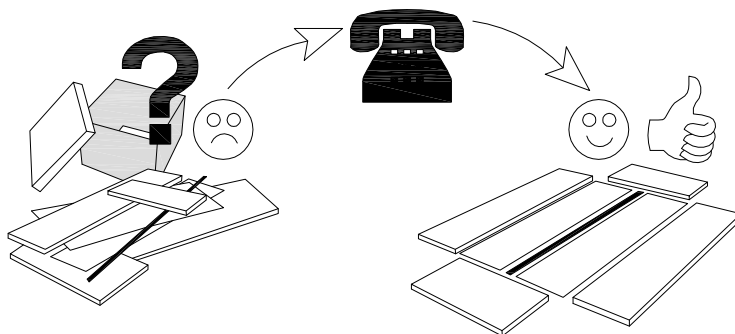
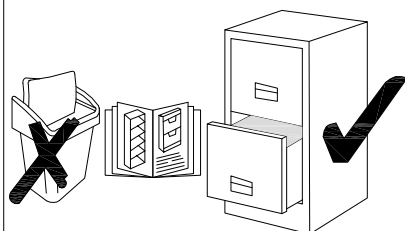

Nr. - No. - Номер

Typ - Type - Тип - Тип

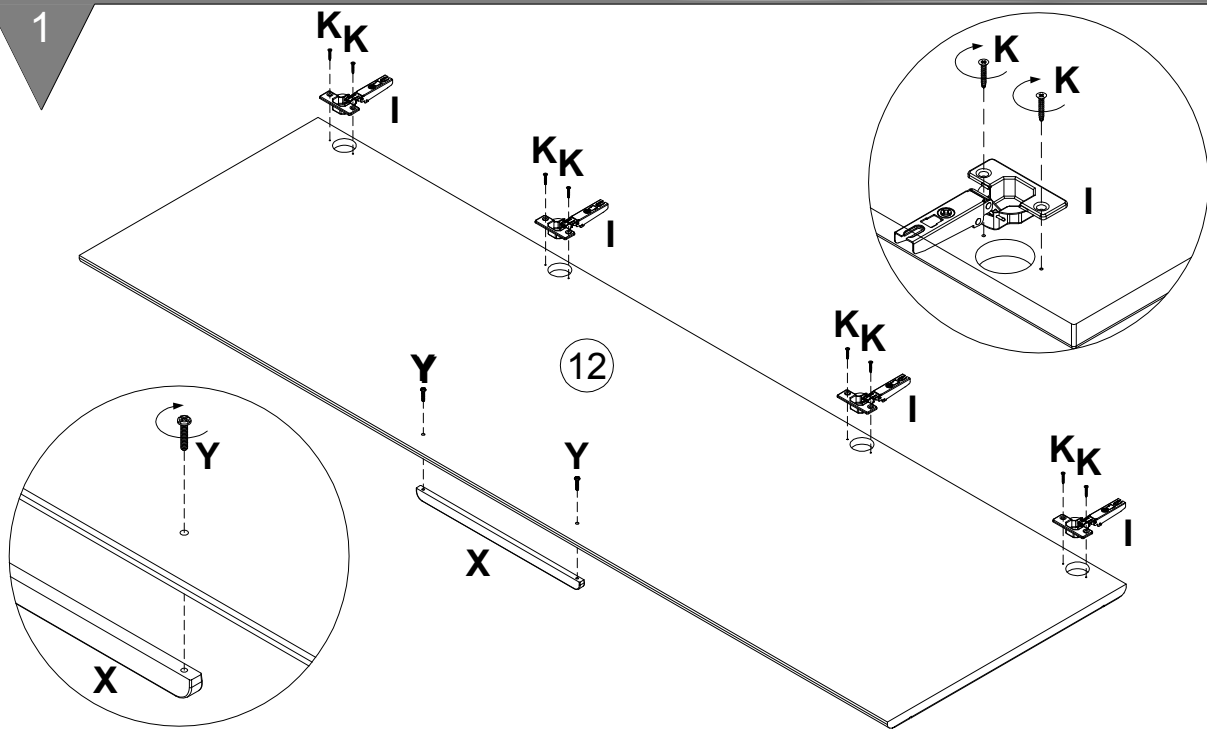

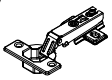



1

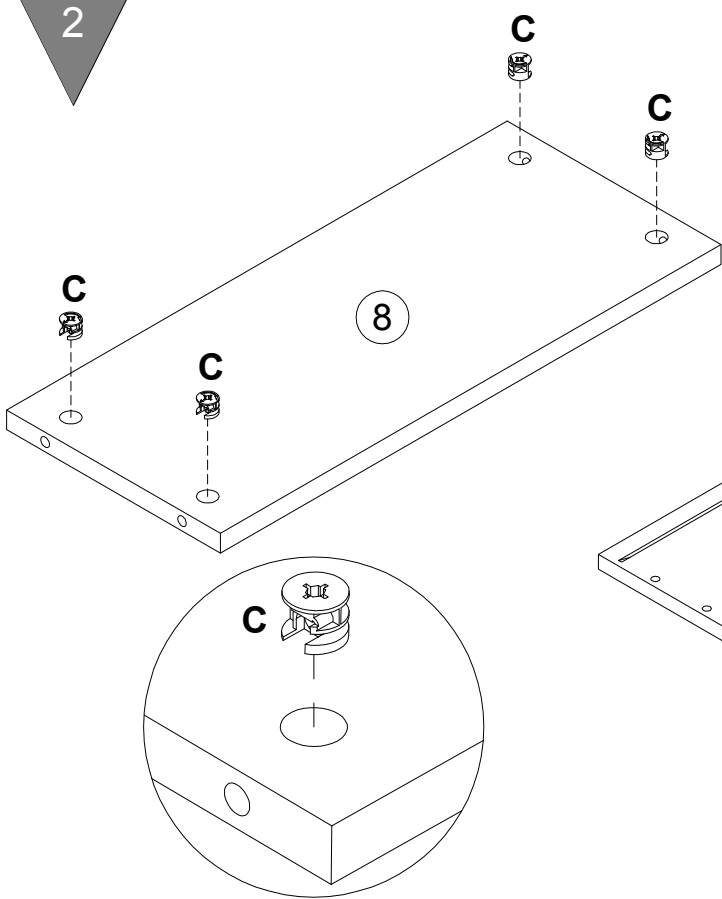

- I** 168982  **x4**
- K** 010942  **4x16**
x8
- X** 265644  **X1**
- Y** 005960  **M4x25**
x2



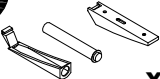

2

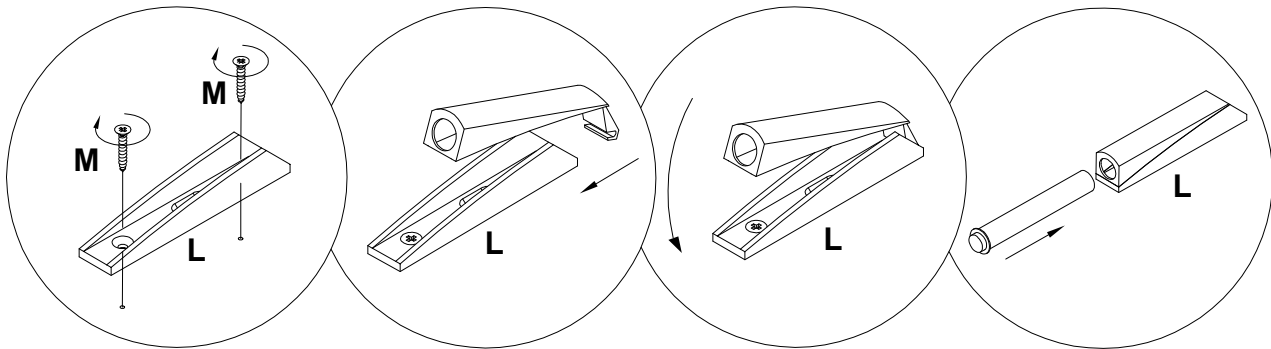
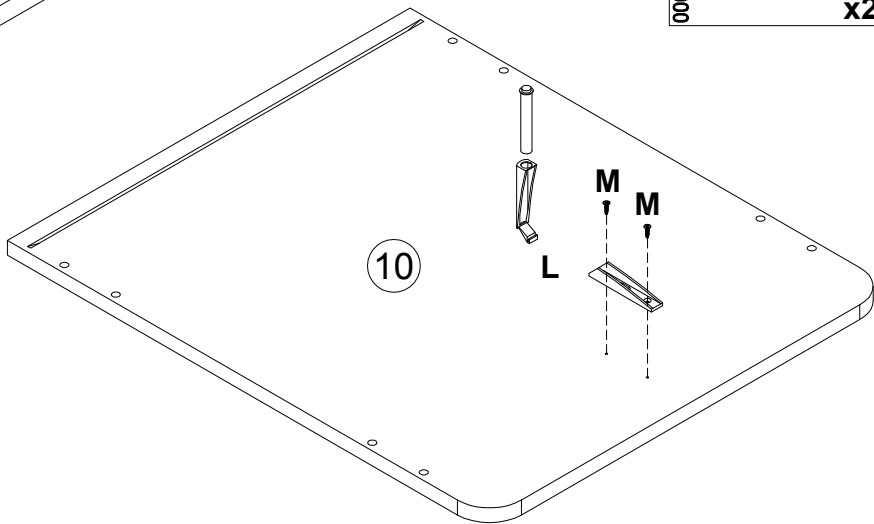

- C** 000146  **15x12**
x4
- L** 156593  **x1**
- M** 000762  **3.5x13**
x2



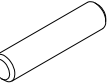

3

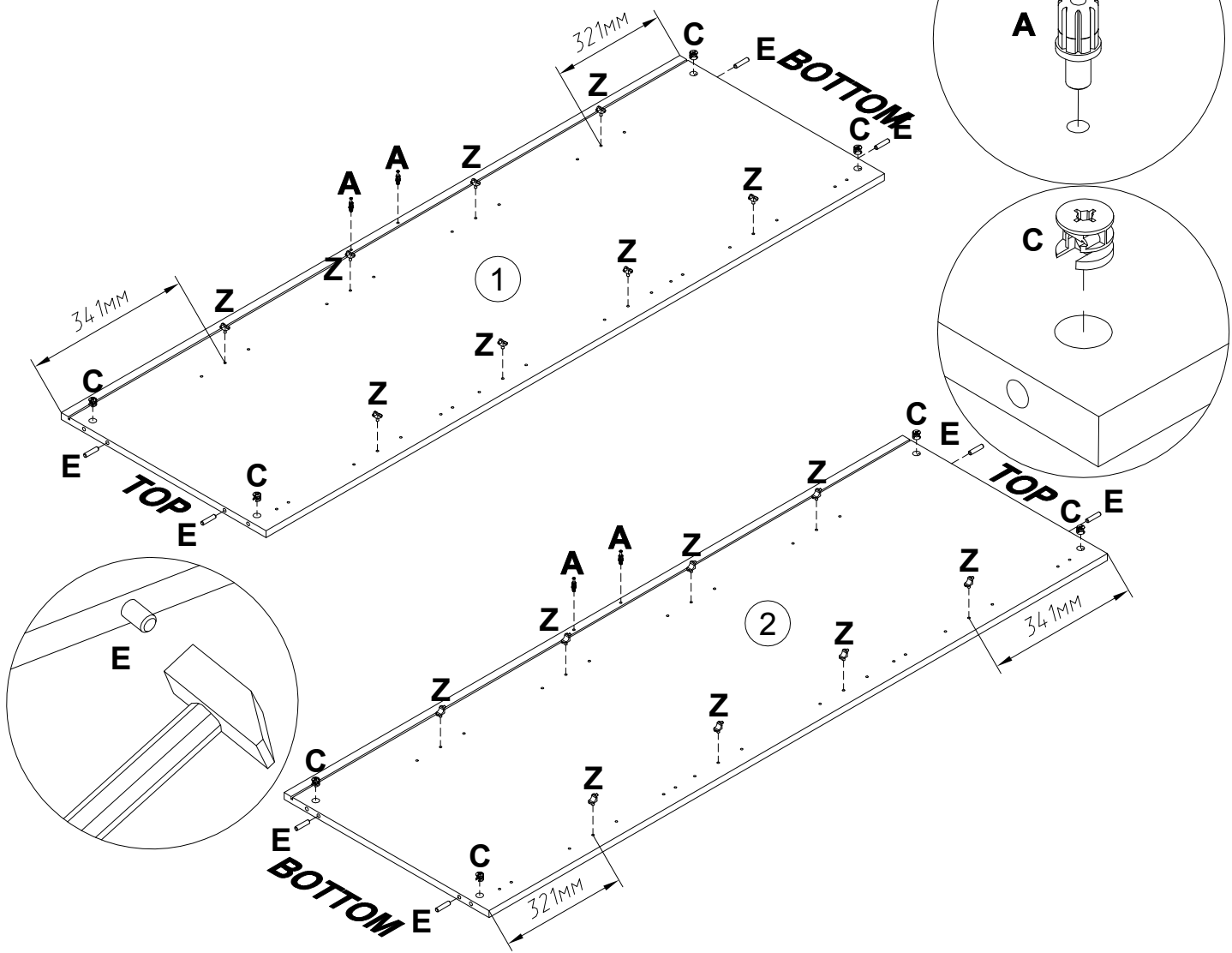
A 090913 	7x32 x4	C 000146 	15x12 x8	E 000151 	8x35 x8	Z 125913 	x16
---	-------------------	---	--------------------	---	-------------------	---	------------



4

C 000146 	15x12 x8
E 000151 	8x35 x8

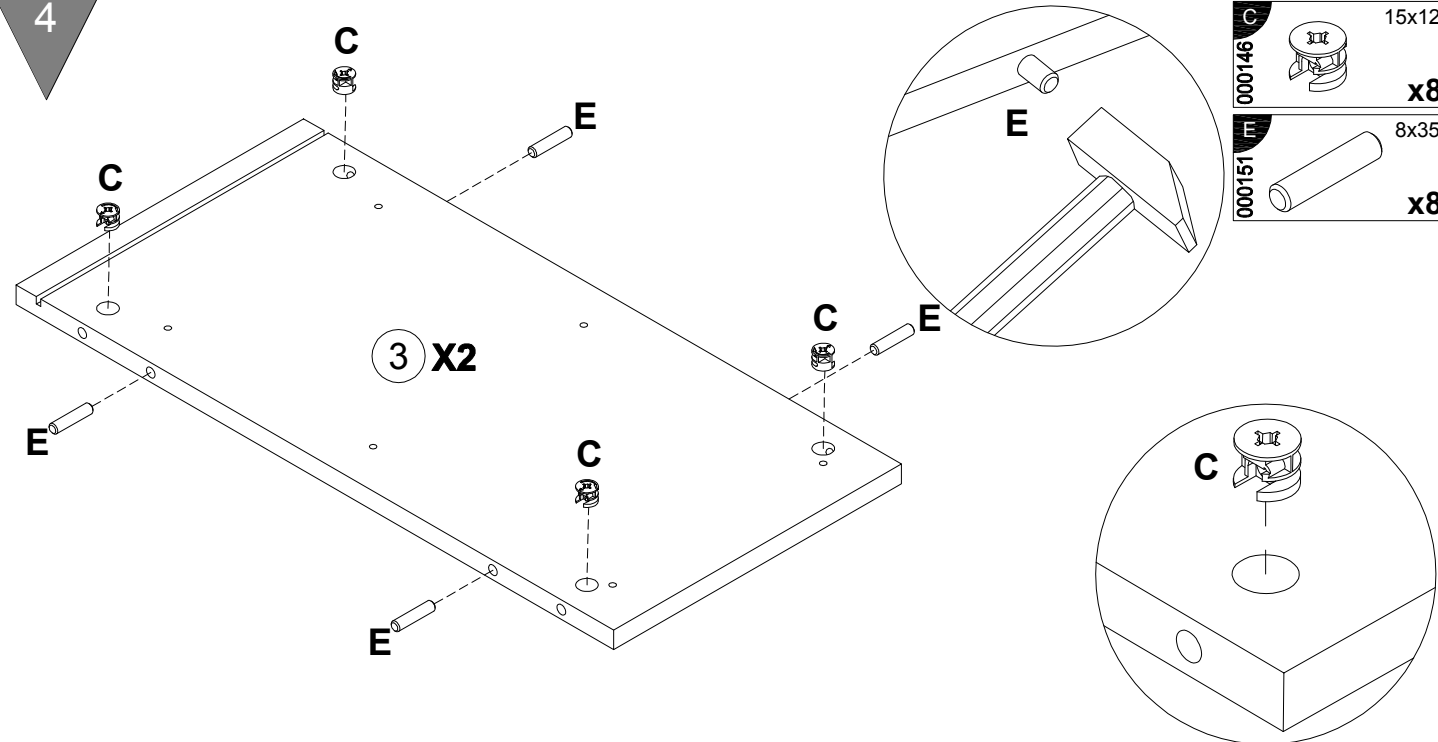

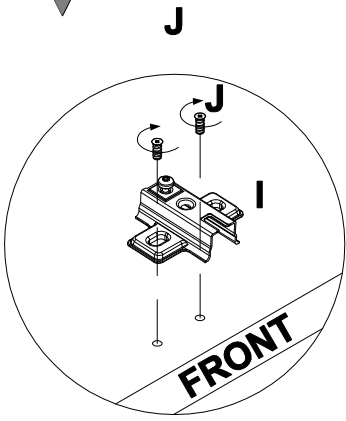

5

5

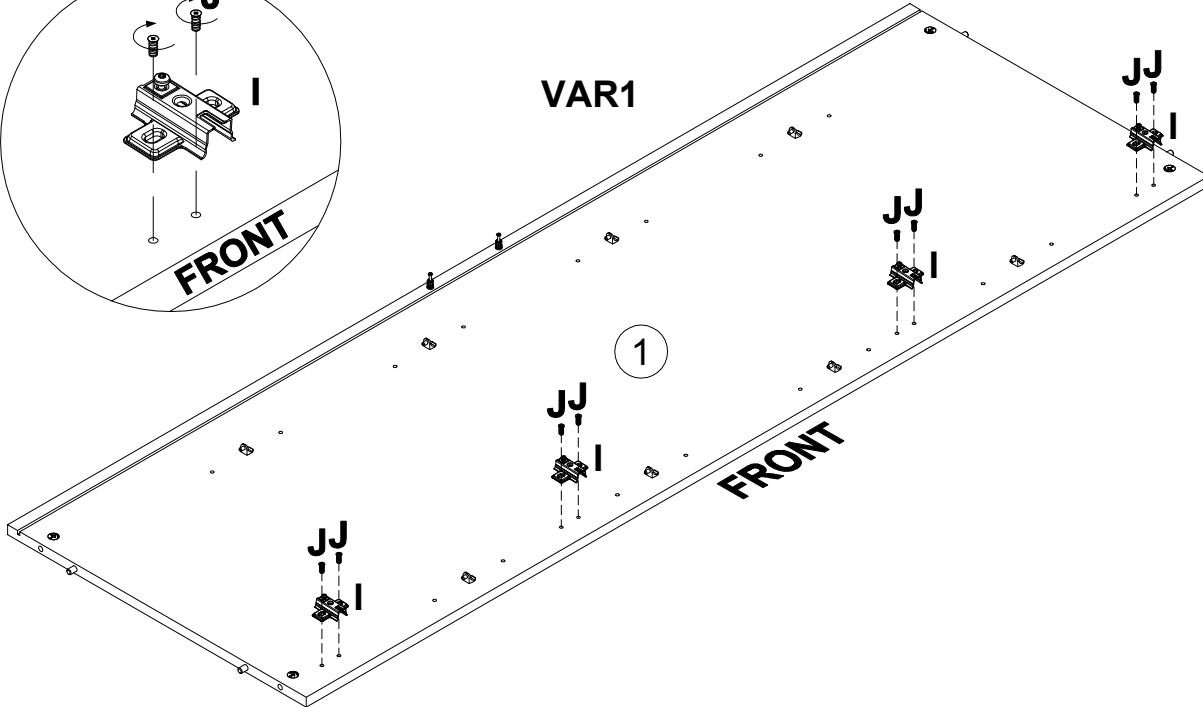

VAR1

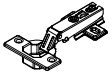

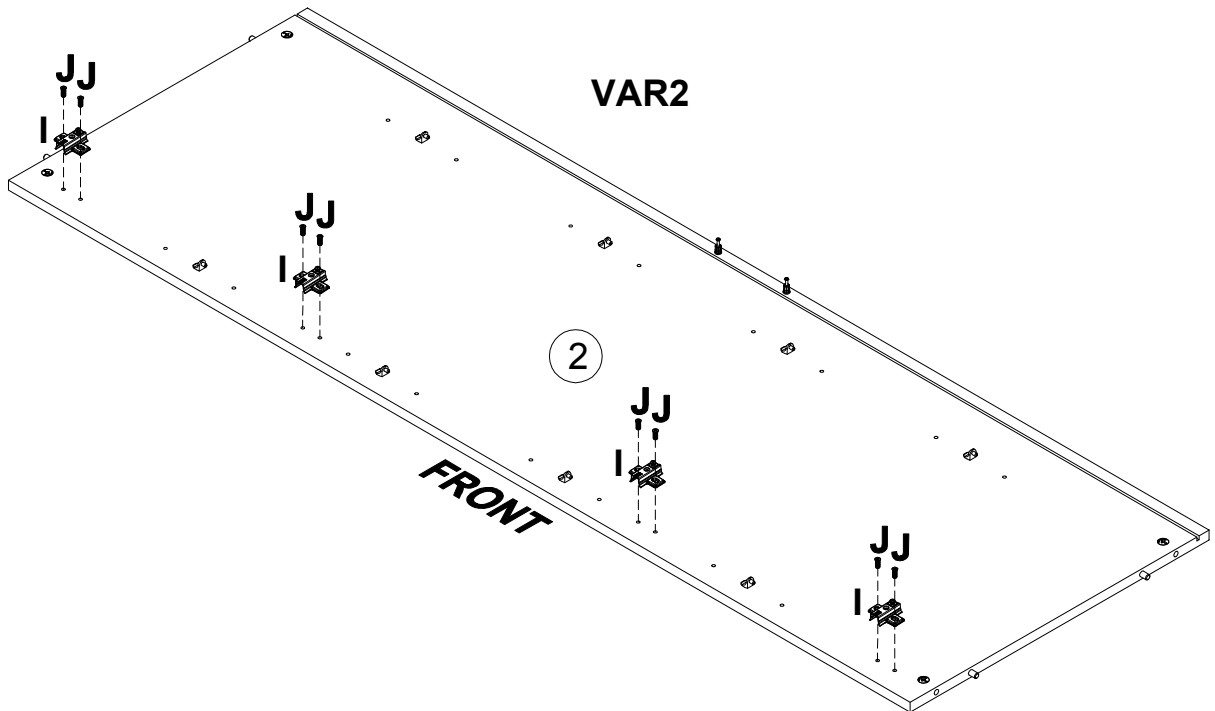

168982		x4
235594		6.3x16 x8

VAR2





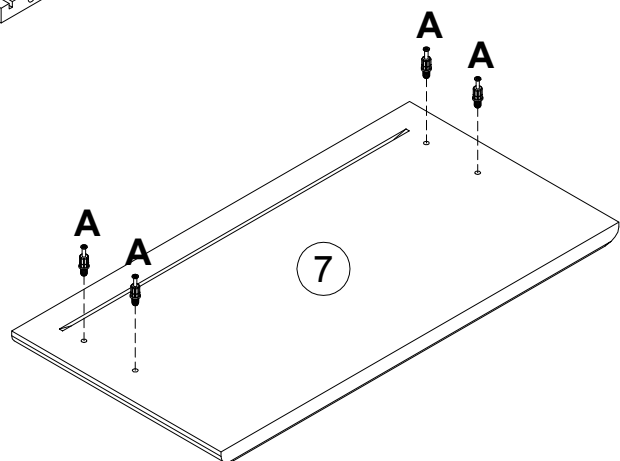
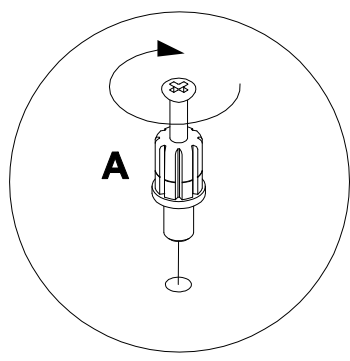
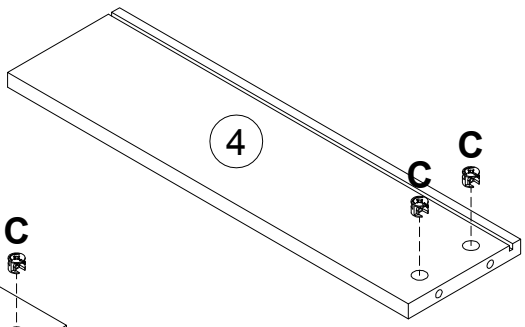
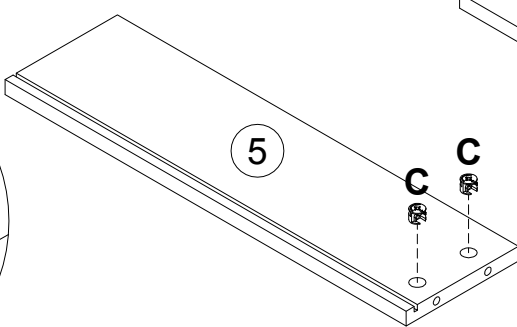
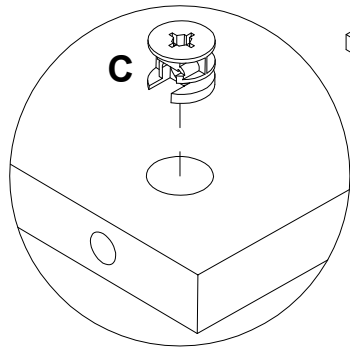

6

6

A		7x32	C		15x12
090913		x4	000146		x4



7

A		7x32
090913		x4
U		22x16
230041		x4
V		M6
007086		x4
W		M6x16
208693		x4

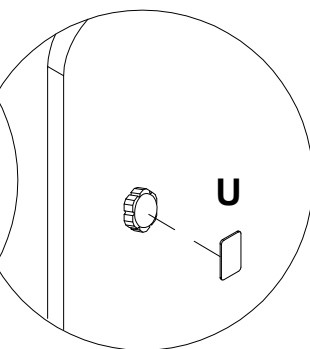
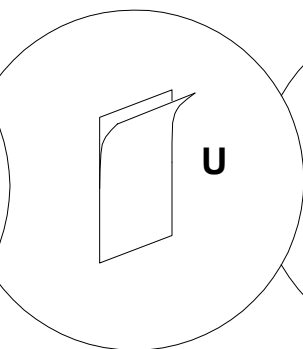
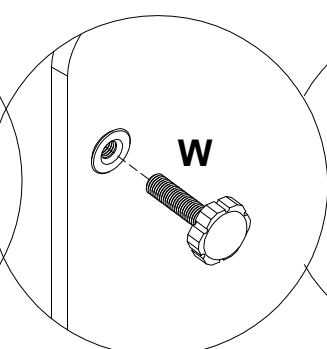
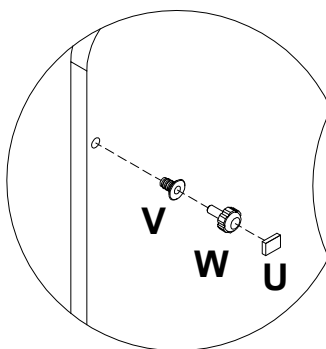
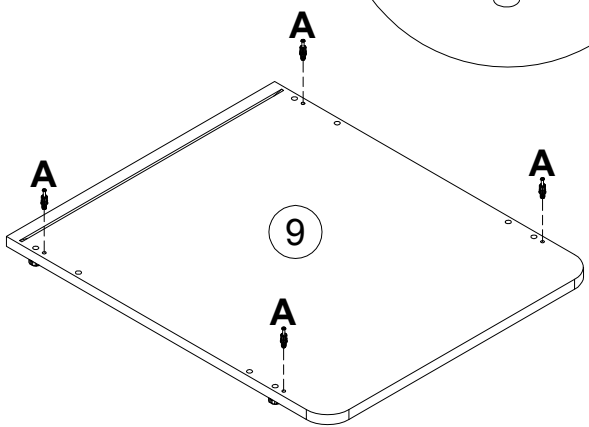
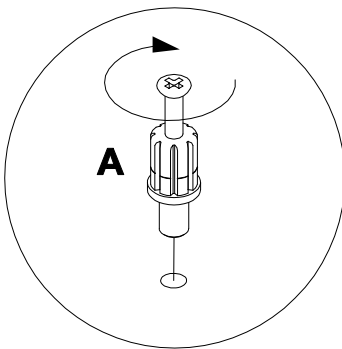
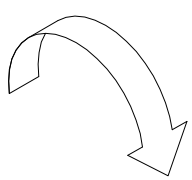
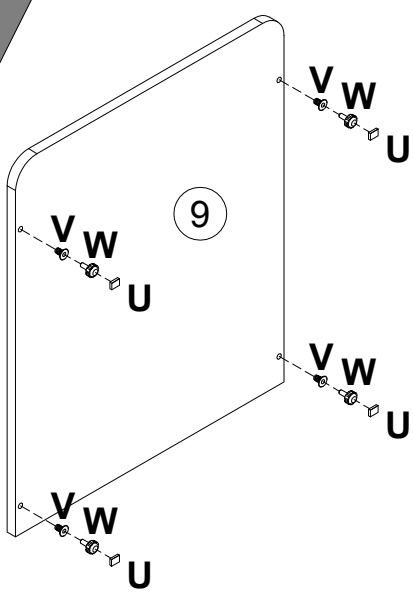

8

A
0900913 7x32
x4

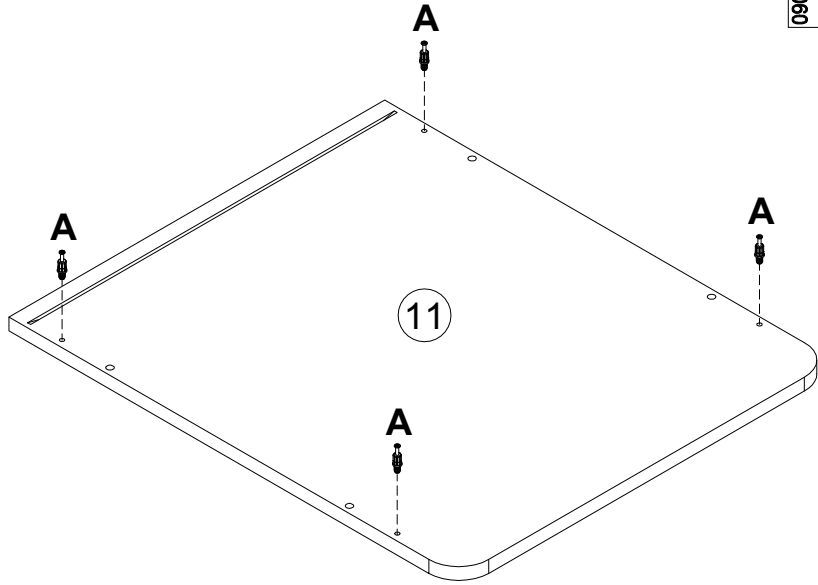
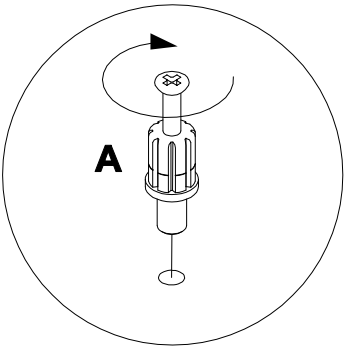

9

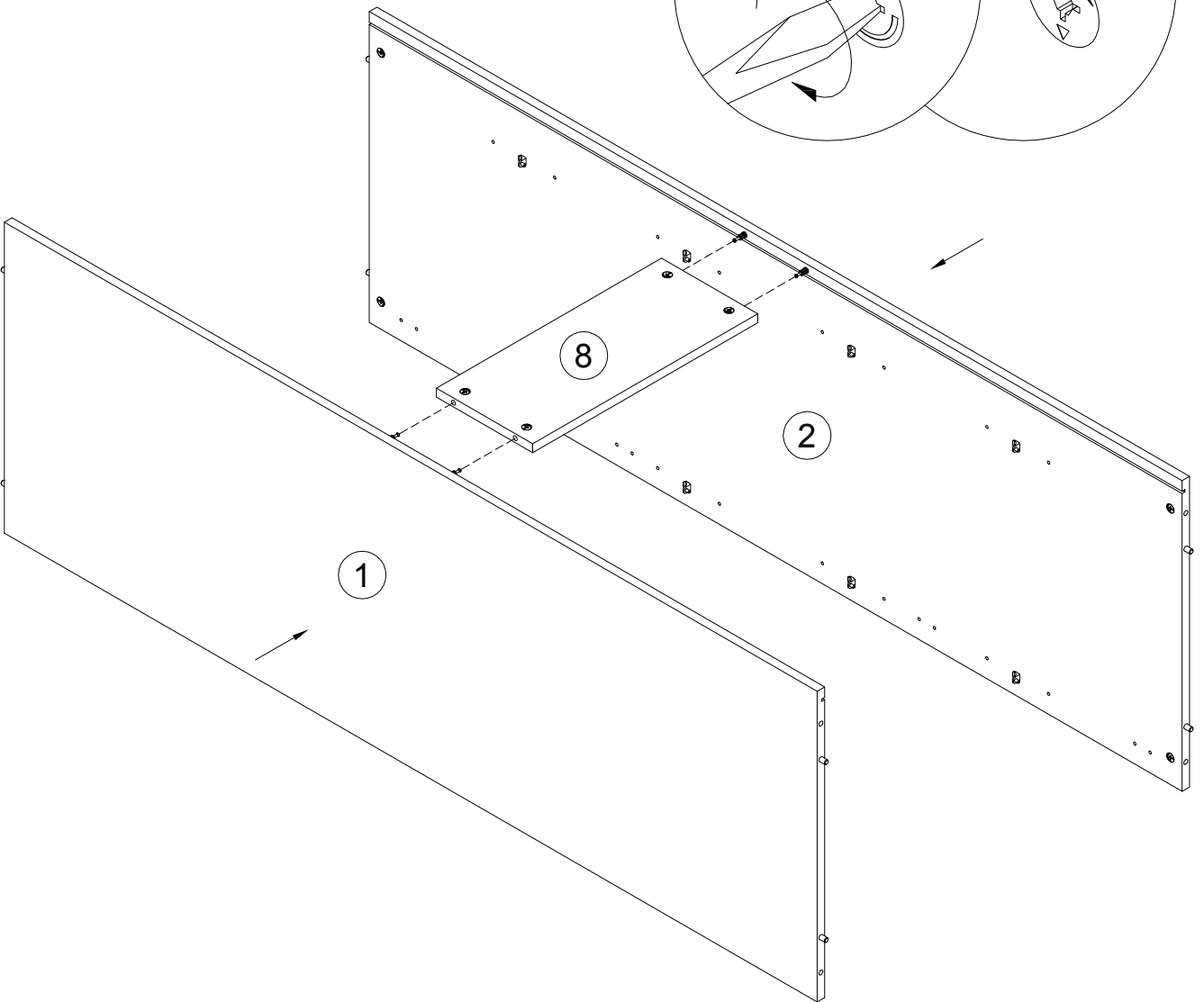
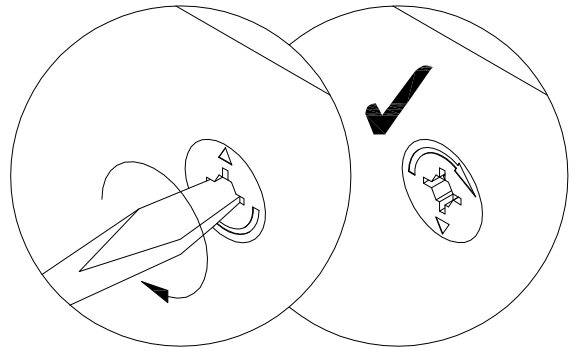

8

10

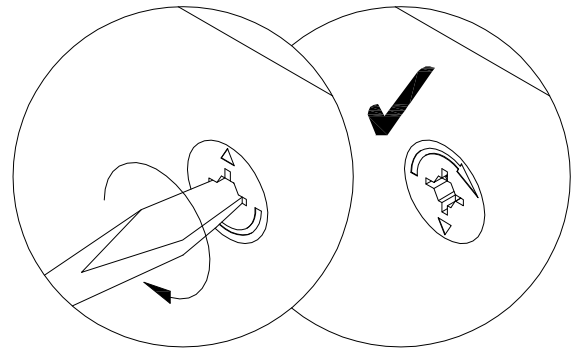
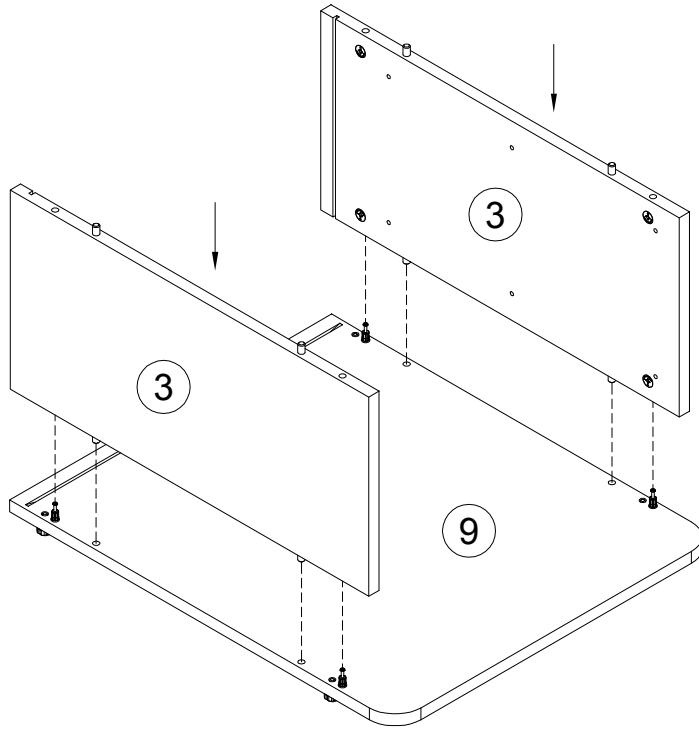

11

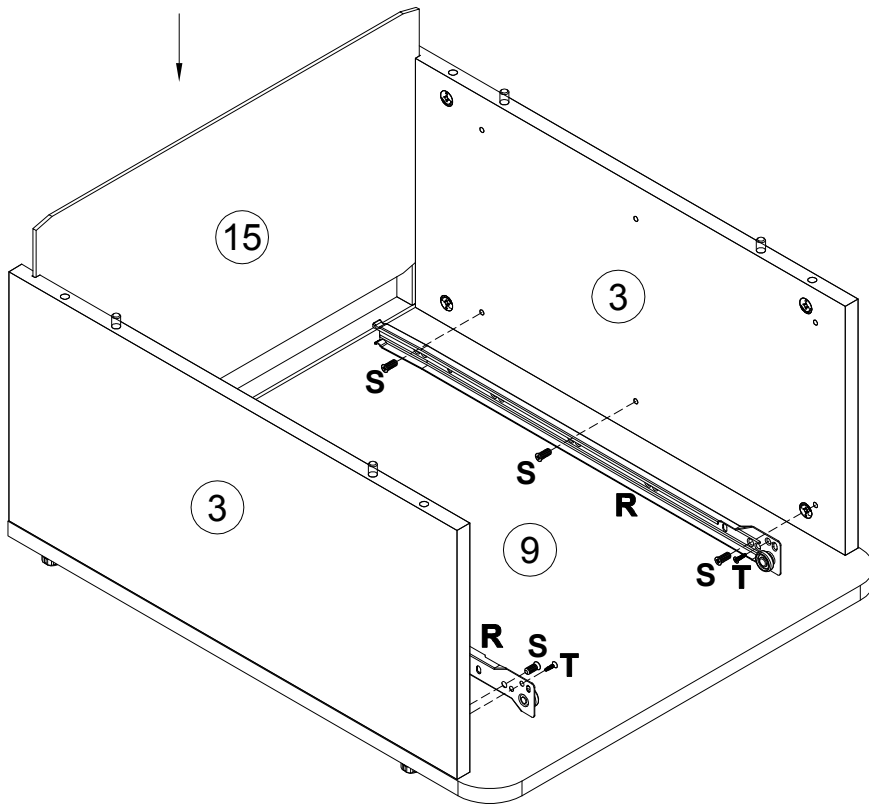

R		L500
167334		x1
S		6x8
235593		x6
T		3x13
000767		x2

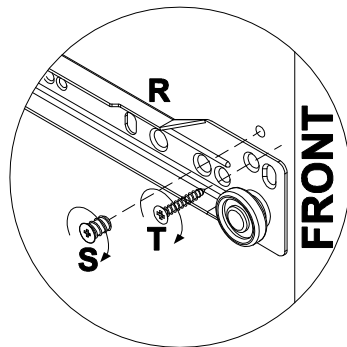
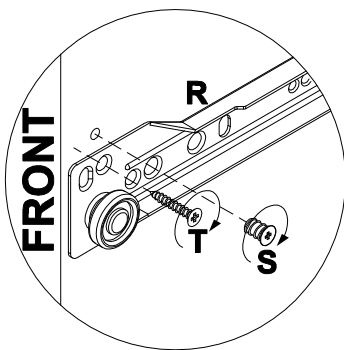

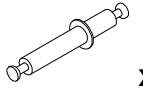

12

122925



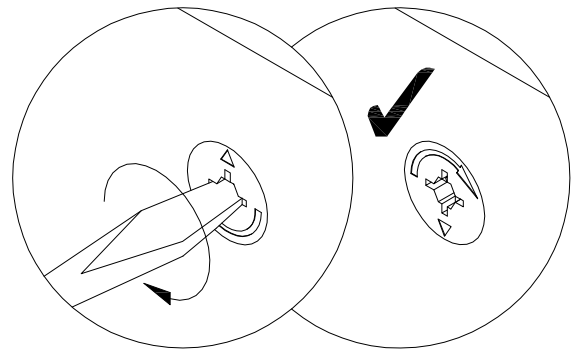
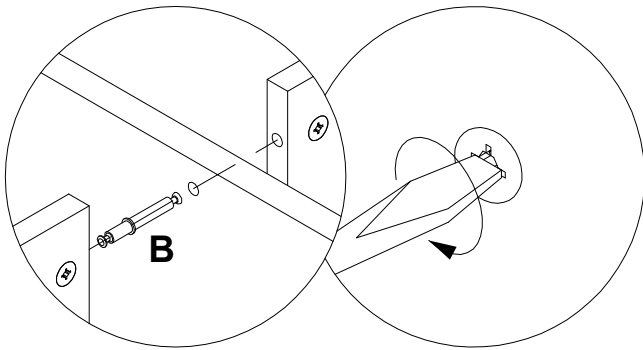
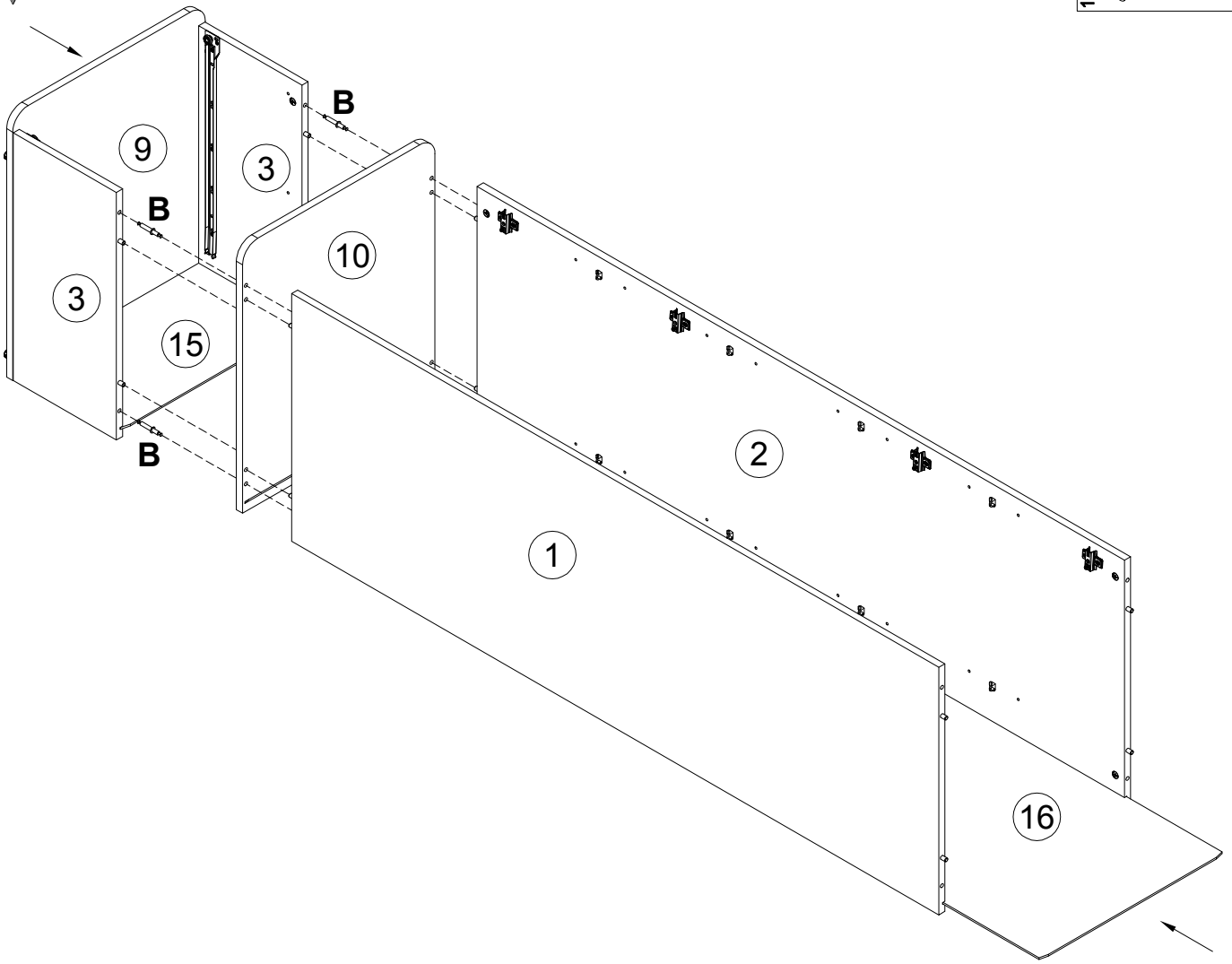

x4

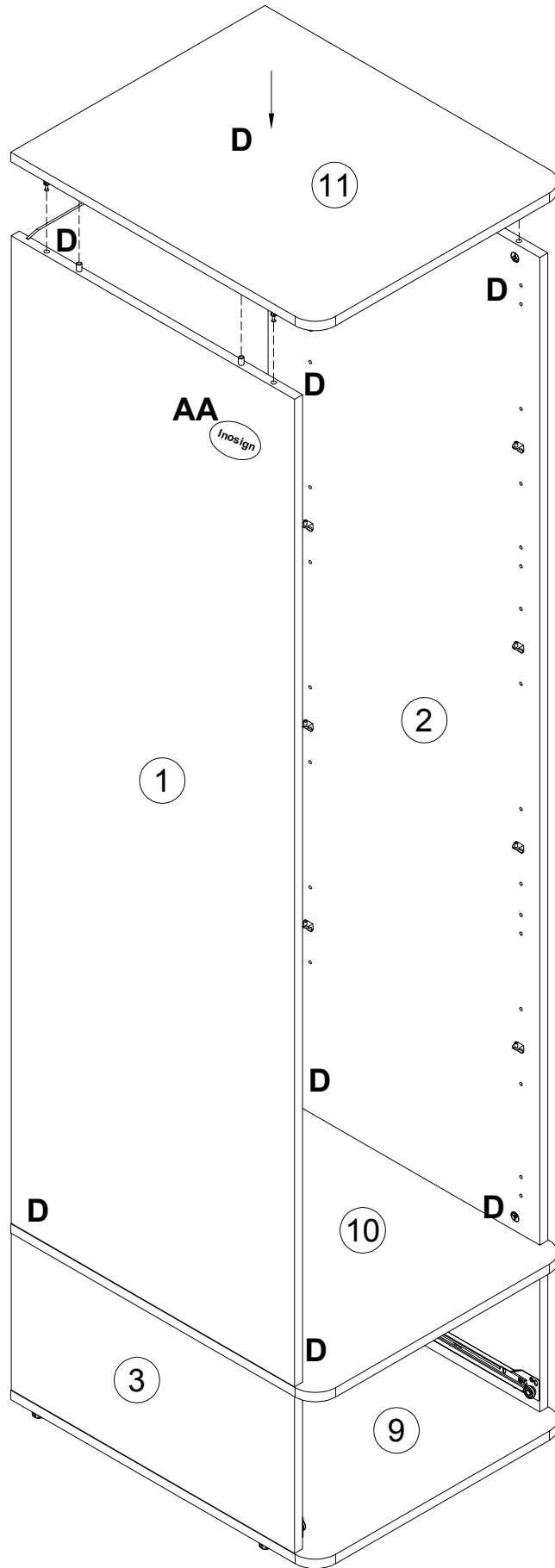

D	20x0.5
100640	
	x8
AA	inogn
238966	
	x1



F		x16
G		3x20 x16

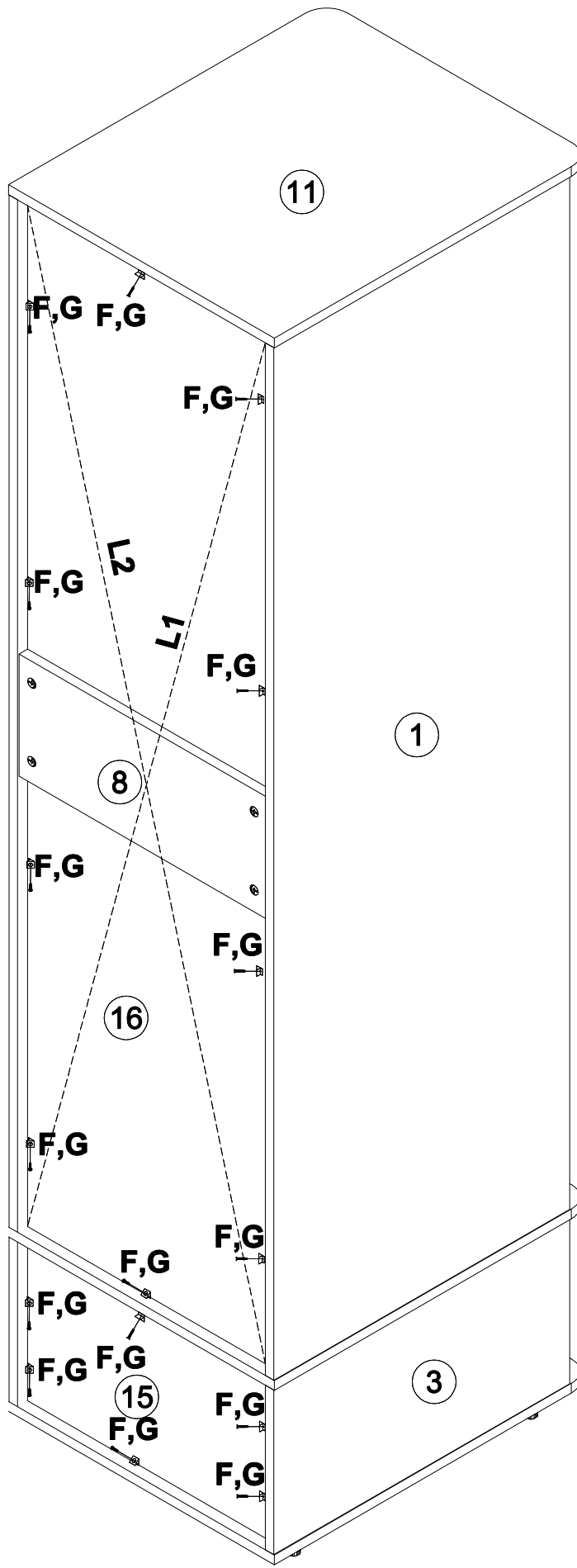

L1=L2

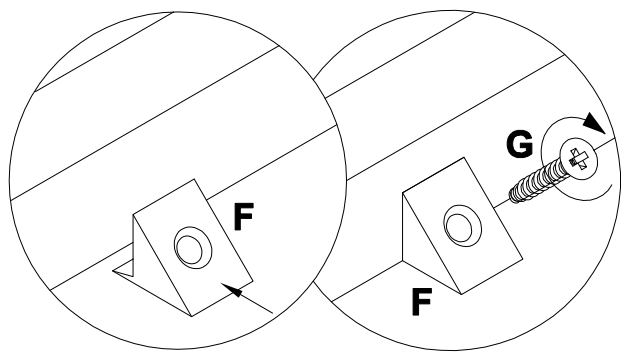

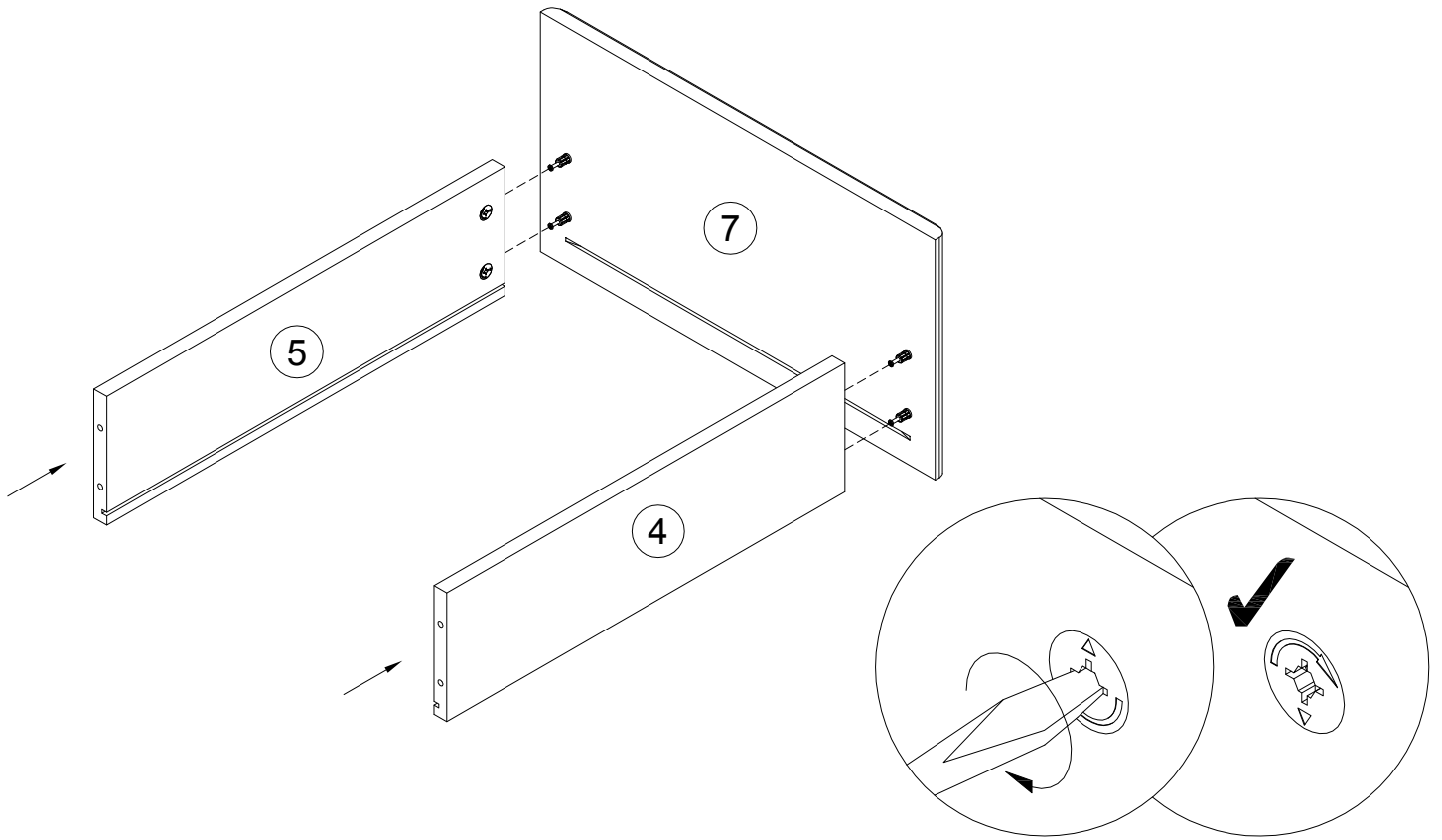

15



16

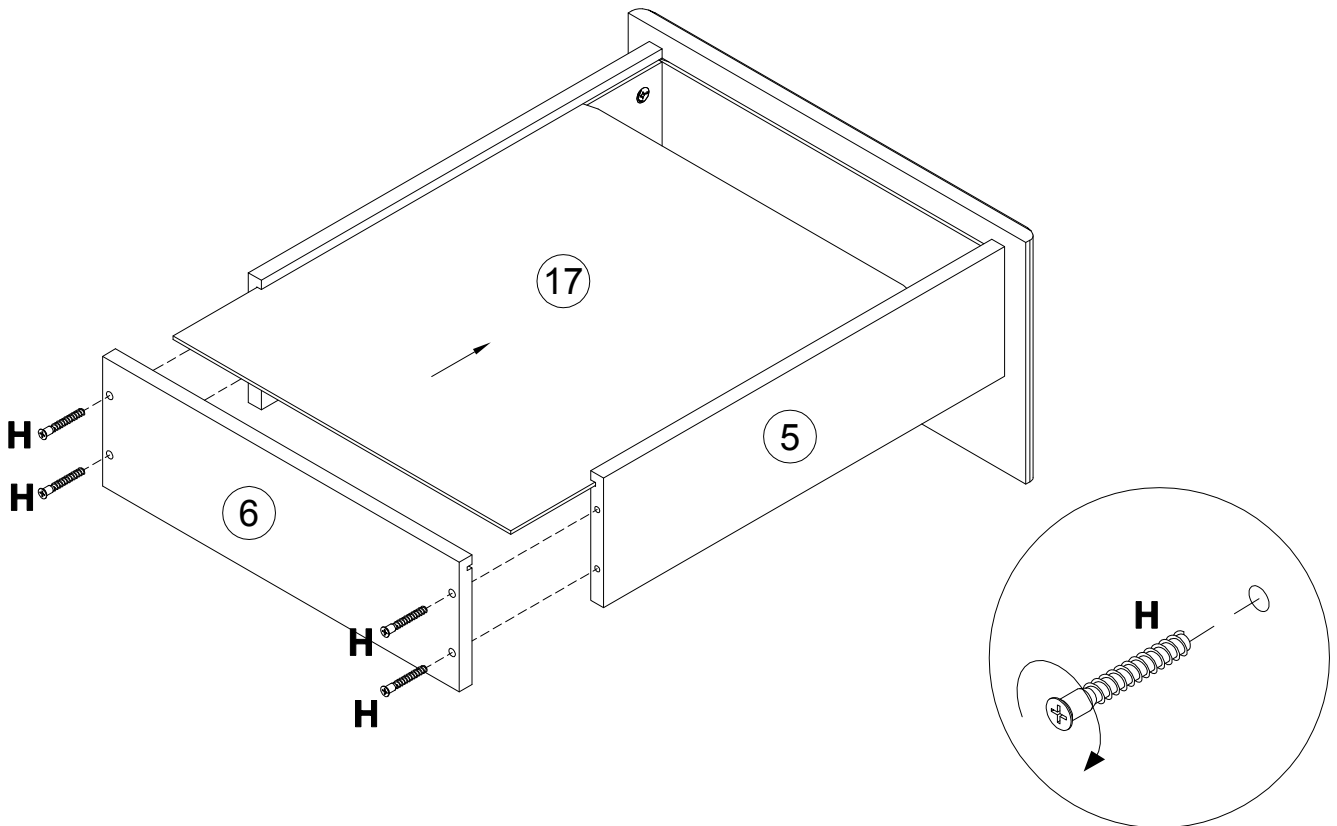

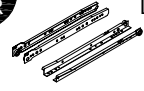

H
101608 7x50
x4

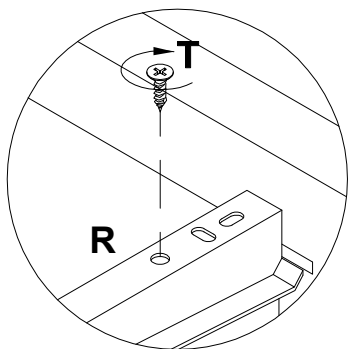
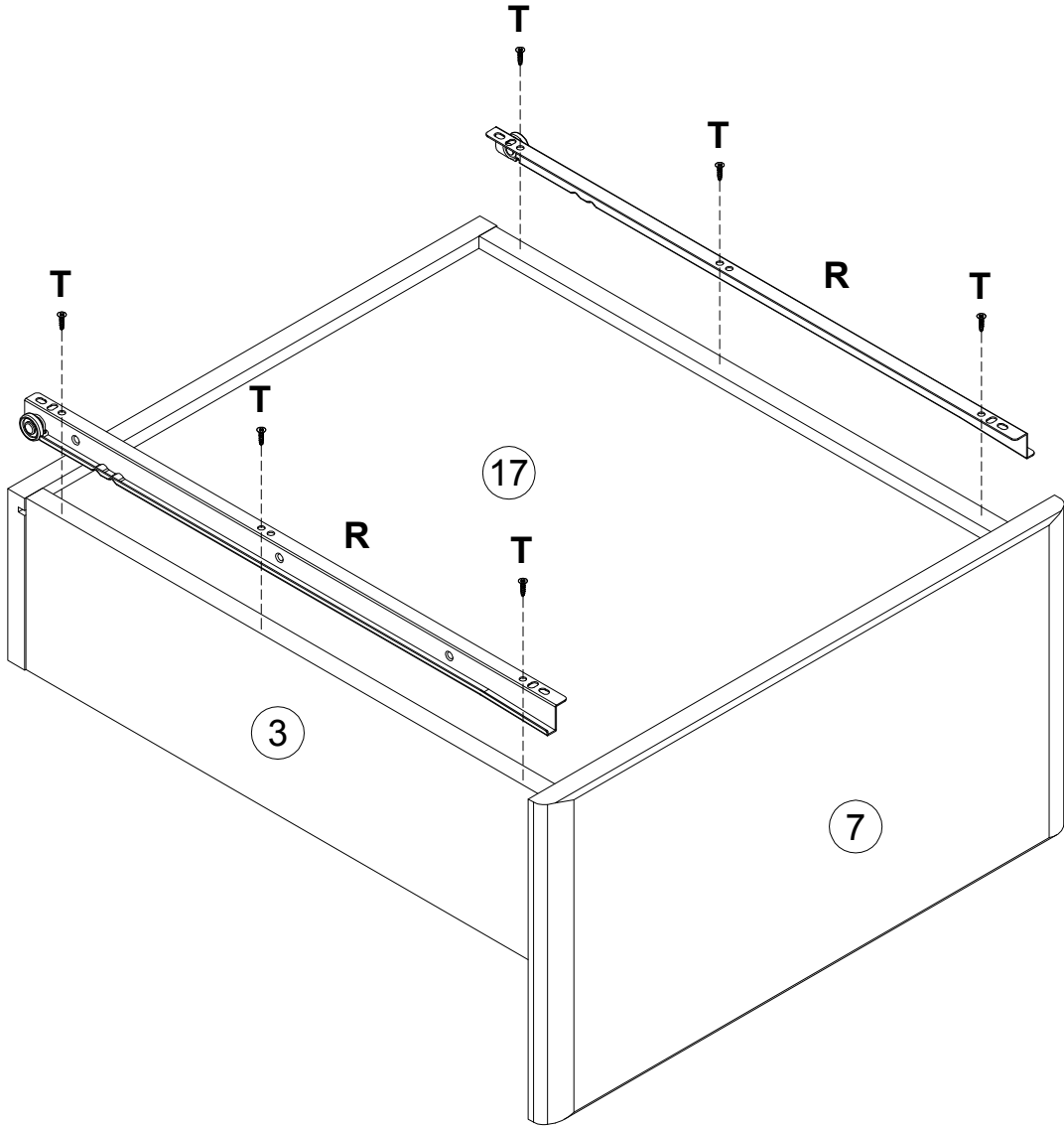

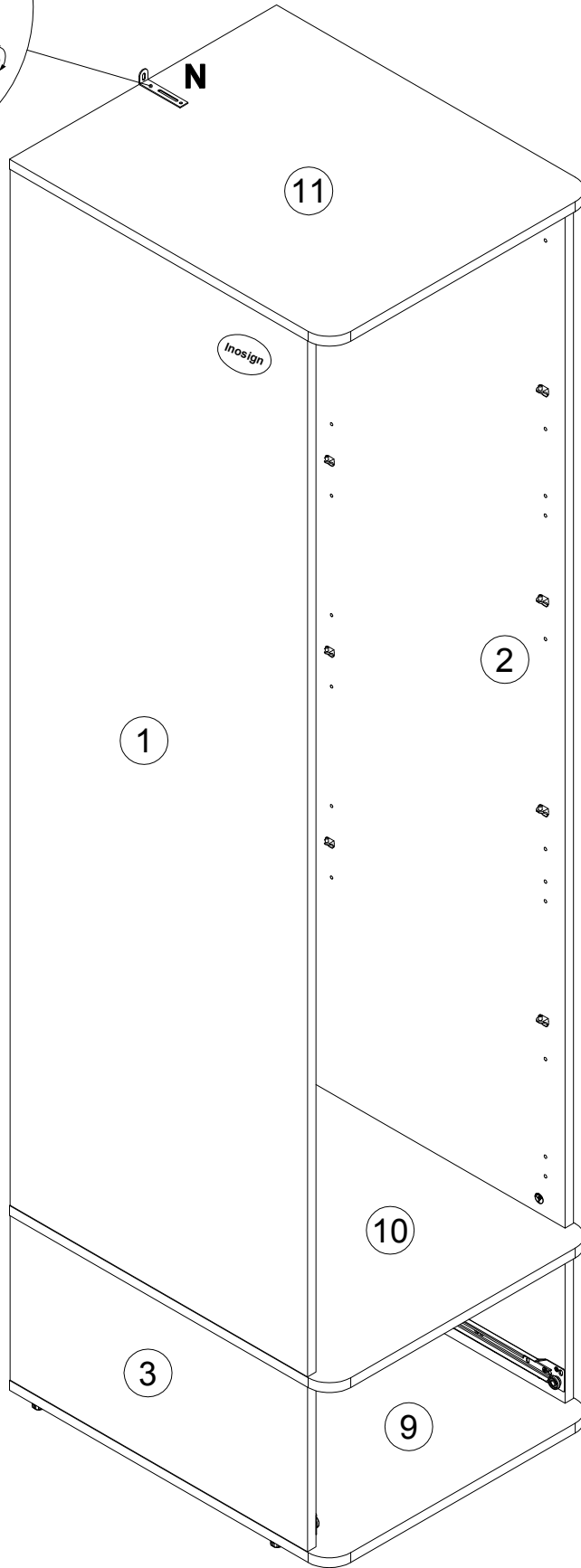
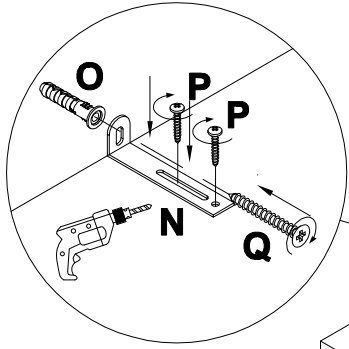
R		L500
167334		x1
T		3x13
000767		x6

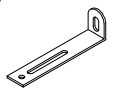



- N** 155999  **x1**
- O** 013859  8x40 **x1**
- P** 000754  3.5x16 **x2**
- Q** 090185  4.5x45 **x1**

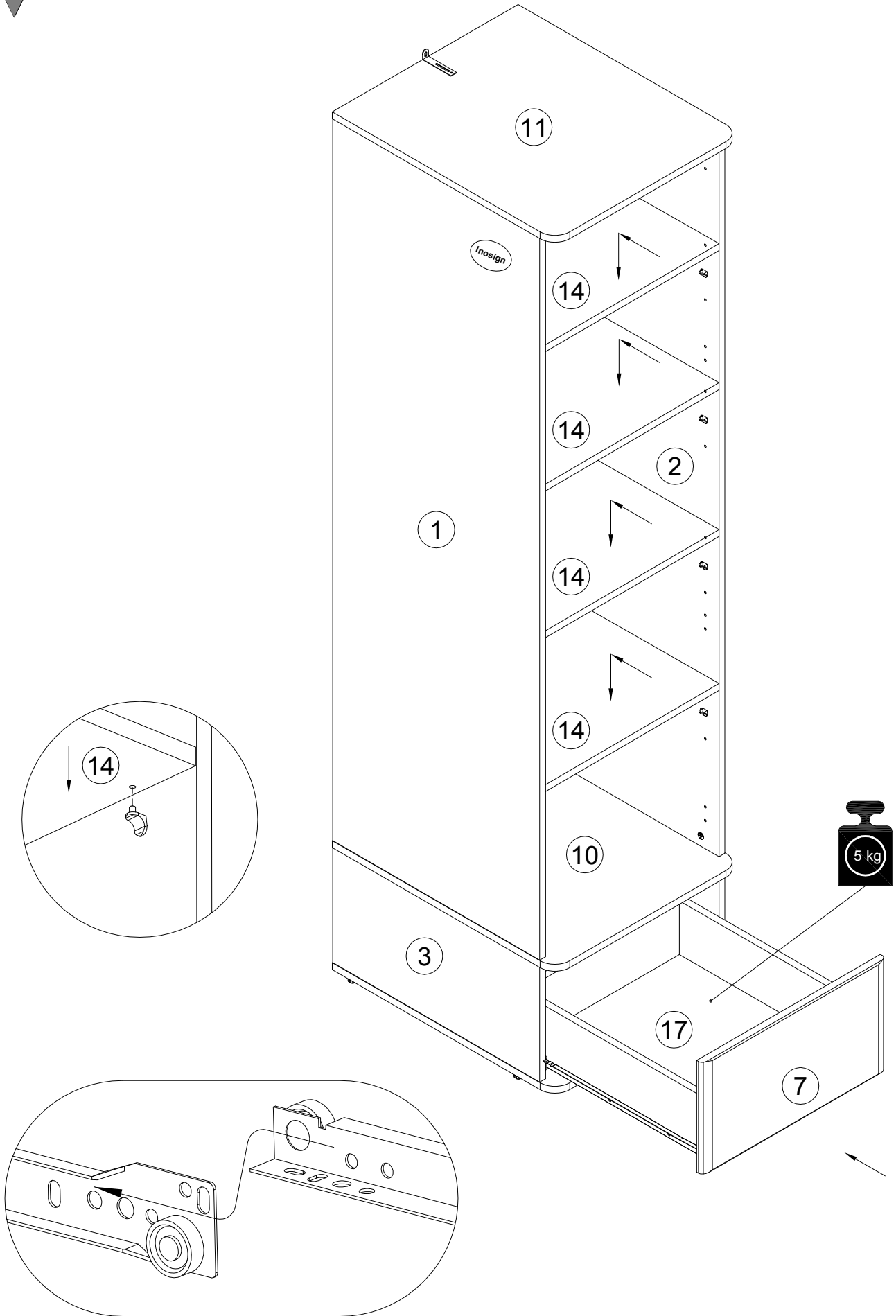

VAR1

VAR2

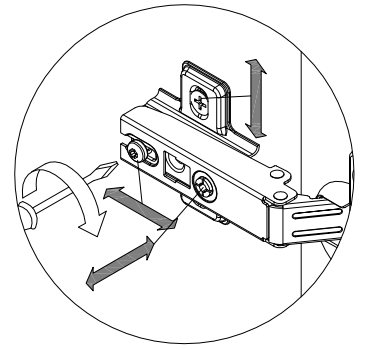
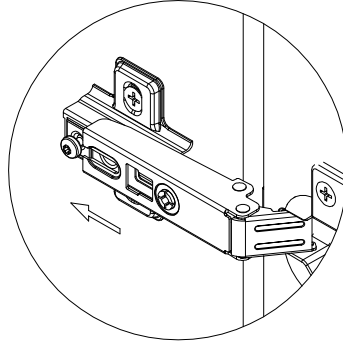
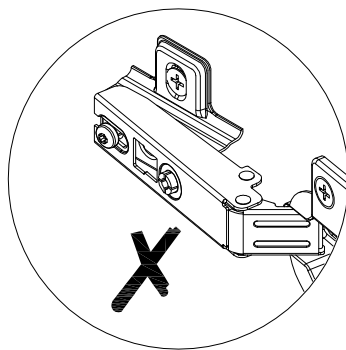
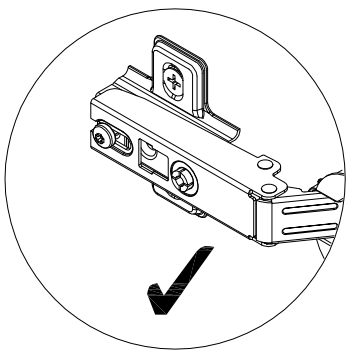
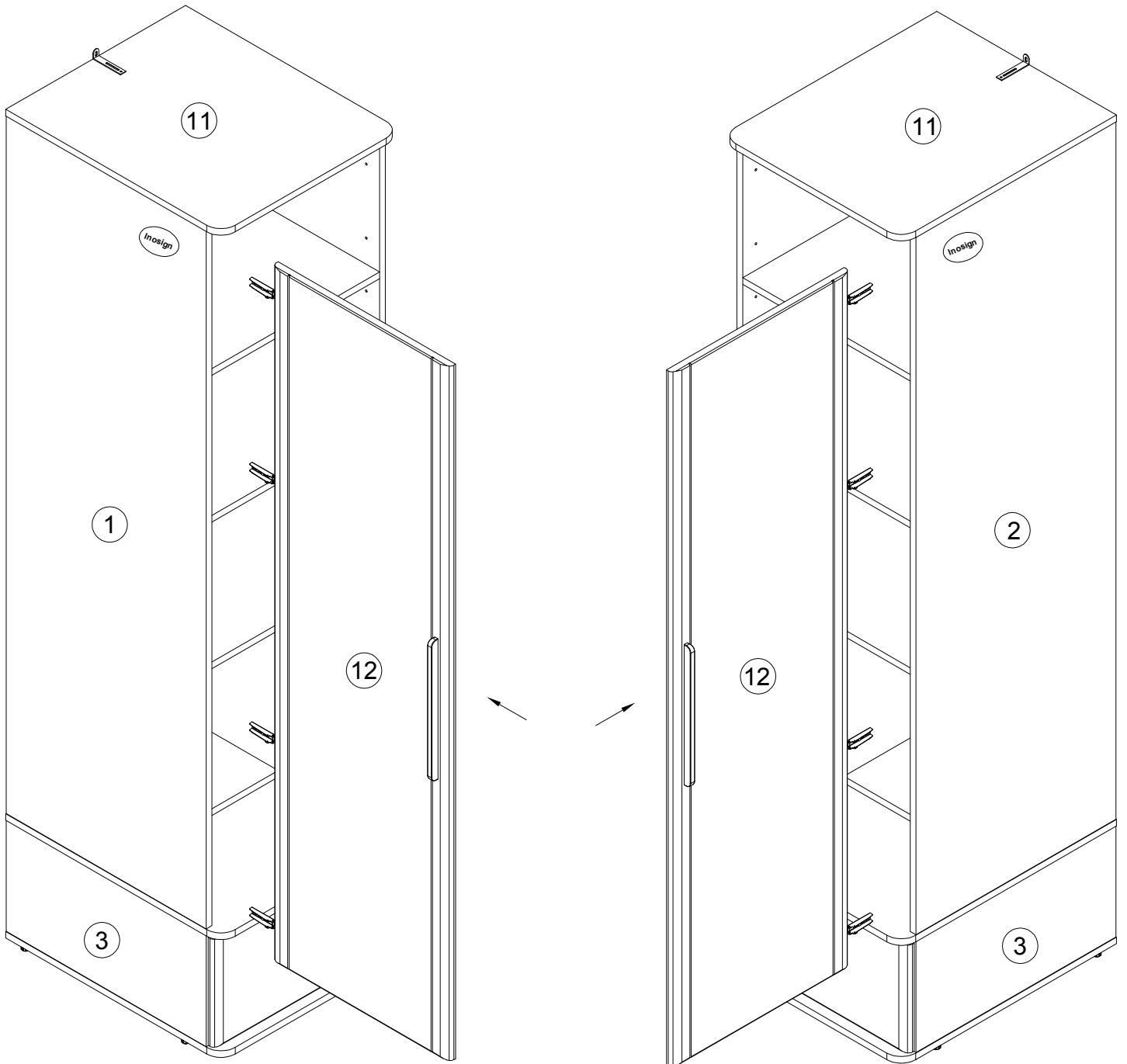



Achtung • Attention • Attenzione
Opgelet • Uwaga • Pozor • Figyelem
Atenție • Dikkat • Внимание

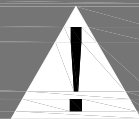

(D)	Wandbefestigung dient als Kippschutz – unbedingt anbringen! Bei einigen Wandtypen kann ein Spezialdübel erforderlich sein!
(GB)	The wall fastening serves to prevent tipping – be absolutely sure to mount it! For certain wall types, a special wall plug may be necessary!
(FR)	La fixation murale sert de protection contre le basculement – à installer impérativement ! Pour certains types de murs il faut des chevilles spéciales !
(IT)	Il fissaggio alla parete serve da protezione anti-ribaltamento – attaccarla assolutamente ! Per alcune strutture di parete può essere necessario un tassello speciale !
(NL)	Bevestiging aan de muur dient als kantelbescherming – zeker en vast bevestigen ! Bij enkele muurtypes is een speciale plug misschien vereist !
(PL)	Mocowanie do ściany jest jednocześnie zabezpieczeniem przed przewróceniem – koniecznie zamontować! Do niektórych rodzajów ścian koniecznie zastosować specjalne kołki mocujące.
(CZ)	Montáž na stěnu slouží jako ochrana proti převrhnutí – bezpodmienečně umístěte! Uněkterých typů stěn může být zapotřebí speciální hmoždinka !
(SK)	Upevnenie na stenu slúži ako ochrana proti prevráteniu – bezpodmienečne použite! Pre niektoré druhy stien môže byť potrebná špeciálna hmoždenka !
(HU)	A terméket a falhoz kel rögzíteni, különben az felborulhat! Egyes faltípusoknál speciális tiplit kell használni !
(RO)	Sistemul de fixare la perete servește ca protecție la răsturnare – de montat obligatoriu! Pentru unele tipuri de pereți este posibil să fie necesar un diblu special !
(TR)	Duvardaki sabitleme, devrilmeye karşı bir emniyet tedbiridir ve mutlaka monte edilmelidir! Bazı duvar tiplerinde bunun için özel bir dübel gereklidir !
(RU)	Обязательно установите крепление на стене во избежание опрокидывания ! Для некоторых типов стен может потребоваться специальный дюбель !