

2572L2TI

PARISOT INDUSTRIE 70800 SAINT LOUP SUR SEMOUSE -FRANCE-

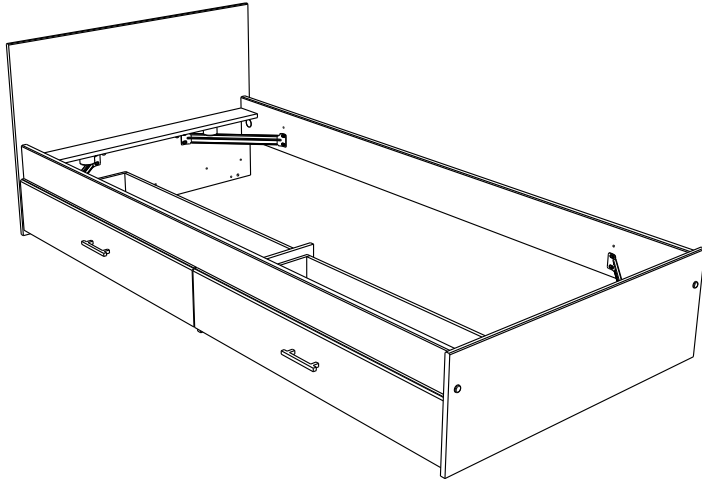

IMPORTANT KEEP FOR FUTURE REFERENCE

WARNING: NOT SUITABLE FOR CHILDREN UNDER 6 YEARS.
 WARNING: DO NOT PLACE THIS CHILD'S BED NEAR HEAT SOURCES, WINDOWS AND OTHER FURNITURE.
 WARNING: DO NOT USE THIS CHILD'S BED IF ANY PART IS BROKEN, TORN OR MISSING.

IMPORTANT : CONSERVER CETTE NOTICE POUR UTILISATION FUTURE

ATTENTION ! NE PAS UTILISER POUR ENFANTS DE MOINS DE 6 ANS.
 ATTENTION ! NE PAS PLACER CE LIT ENFANT PRES DE SOURCES DE CHALEUR, DE FENETRES ET D'AUTRES MEUBLES.
 ATTENTION ! NE PAS UTILISER CE LIT POUR ENFANT SI UNE PIECE EST CASSEE, DECHIREE OU MANQUANTE.

Gamme : SNOOP

FR Remerciements :

Nous vous remercions d'avoir choisi un meuble créé et fabriqué par le Groupe Parisot et espérons qu'il vous donnera entière satisfaction.

EN Thanks:

Thank you for choosing furniture designed and manufactured by the Parisot Group. We hope you are totally satisfied with our purchase.

DE Danksagung:

Wir danken Ihnen für den Kauf eines Frankreich von der Parisot-Gruppe entworfenen und hergestellten Möbelstücks und hoffen, dass Sie es zu Ihrer vollkommenen Zufriedenheit finden werden.

HU Köszönet:

Köszönjük, hogy a Parisot Groupe által létrehozott és gyártott bútort választott, reméljük, hogy elégedett lesz a termékkel.

PT Agradecimentos:

Obrigado por ter escolhido um móvel concebido e fabricado pelo Grupo Parisot, esperando que seja do seu inteiro agrado.

IT Ringraziamenti:

Grazie per avere scelto un mobile progettato e fabbricato dal Gruppo Parisot. Speriamo soddisfatti appieno le vostre esigenze.

NL Bedankje:

Wij bedanken u voor de aankoop van een door de Groep Parisot ontworpen en vervaardigd meubel en hopen dat u er veel plezier aan zult beleven.

CZ Poděkování:

Děkujeme, že jste si vybrali nábytek navrhnutý a vyrobený společností Parisot Group. Doufáme, že budete svým nákupem naprosto spokojeni.

ES Agradecimientos:

Les damos las gracias por haber elegido un mueble diseñado y fabricado por el Grupo Parisot y esperamos que sea de su total agrado.

PL Podziękowania:

Dziękujemy za wybór mebli stworzonych i wyprodukowanych przez Grupę Parisot. Mamy nadzieję, że będziecie Państwo w pełni zadowoleni z zakupu.

SK Pod'akovanie:

Ďakujeme, že ste si vybrali nábytok navrhnutý a vyrobený spoločnosťou Parisot Group. Dúfame, že budete svojim nákupom absolútne spokojní.

AR شكر:

نشكركم لاختياركم هذه القطعة من الأثاث من تصميم وتصنيع مجموعة باريسو Parisot ونتمنى أن تنال رضائكم.

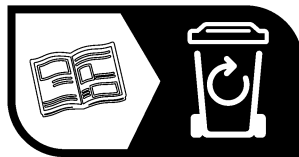
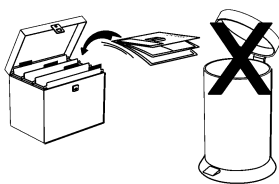

FR

Donnez ou recyclez vos meubles.



ou



ou



Association

Magasin

Déchèterie

<https://quefairedemesdechets.fr>

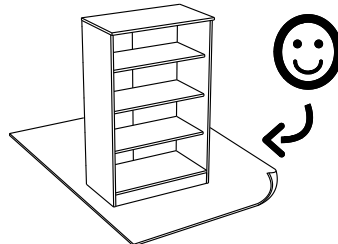
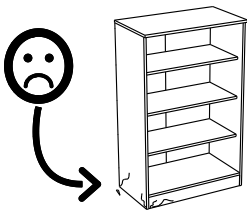
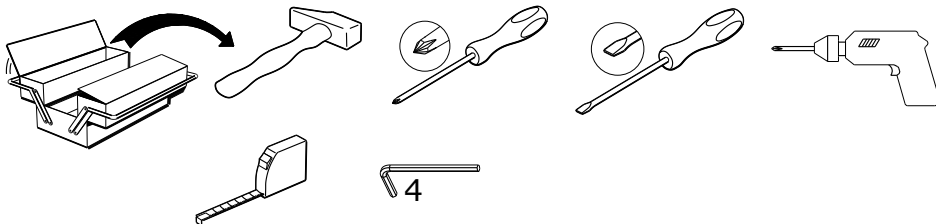

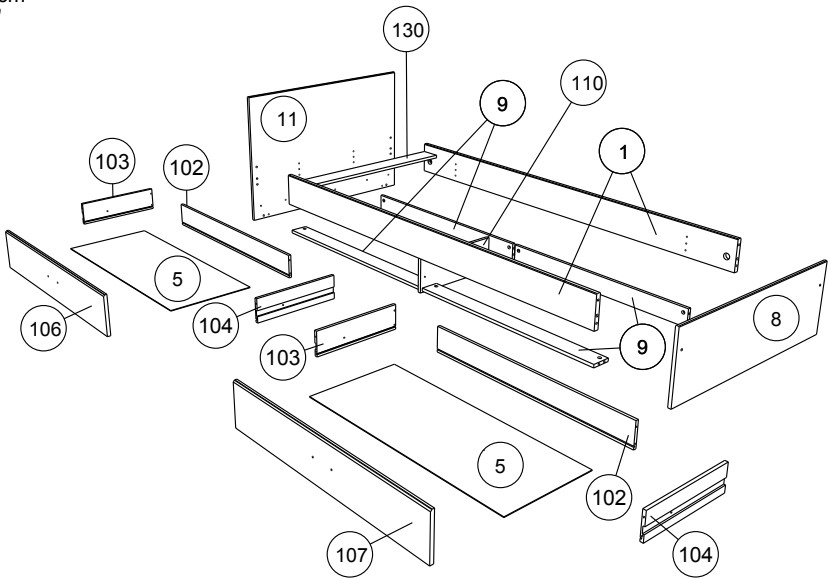
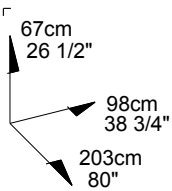

		mm			inch		
(110)	x 1	427	165	15	16 13/16	6 1/2	9/16
(130)	x 1	900	100	15	35 7/16	3 15/16	9/16
(8)	x 1	980	326	15	38 9/16	12 13/16	9/16
(11)	x 1	980	669	15	38 9/16	26 5/16	9/16
(9)	x 4	993	86	15	39 1/16	3 3/8	9/16
(106)	x 1	996	183	15	39 3/16	7 3/16	9/16
(107)	x 1	996	183	15	39 3/16	7 3/16	9/16
(1)	x 2	2000	155	22	78 3/4	6 1/8	7/8
○	x 2	400	110	13	15 3/4	4 5/16	1/2
○	x 2	400	110	13	15 3/4	4 5/16	1/2
○	x 2	960	110	13	37 3/4	4 5/16	1/2
(5)	x 2	971	399	3	38 3/16	15 11/16	1/8

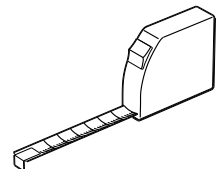

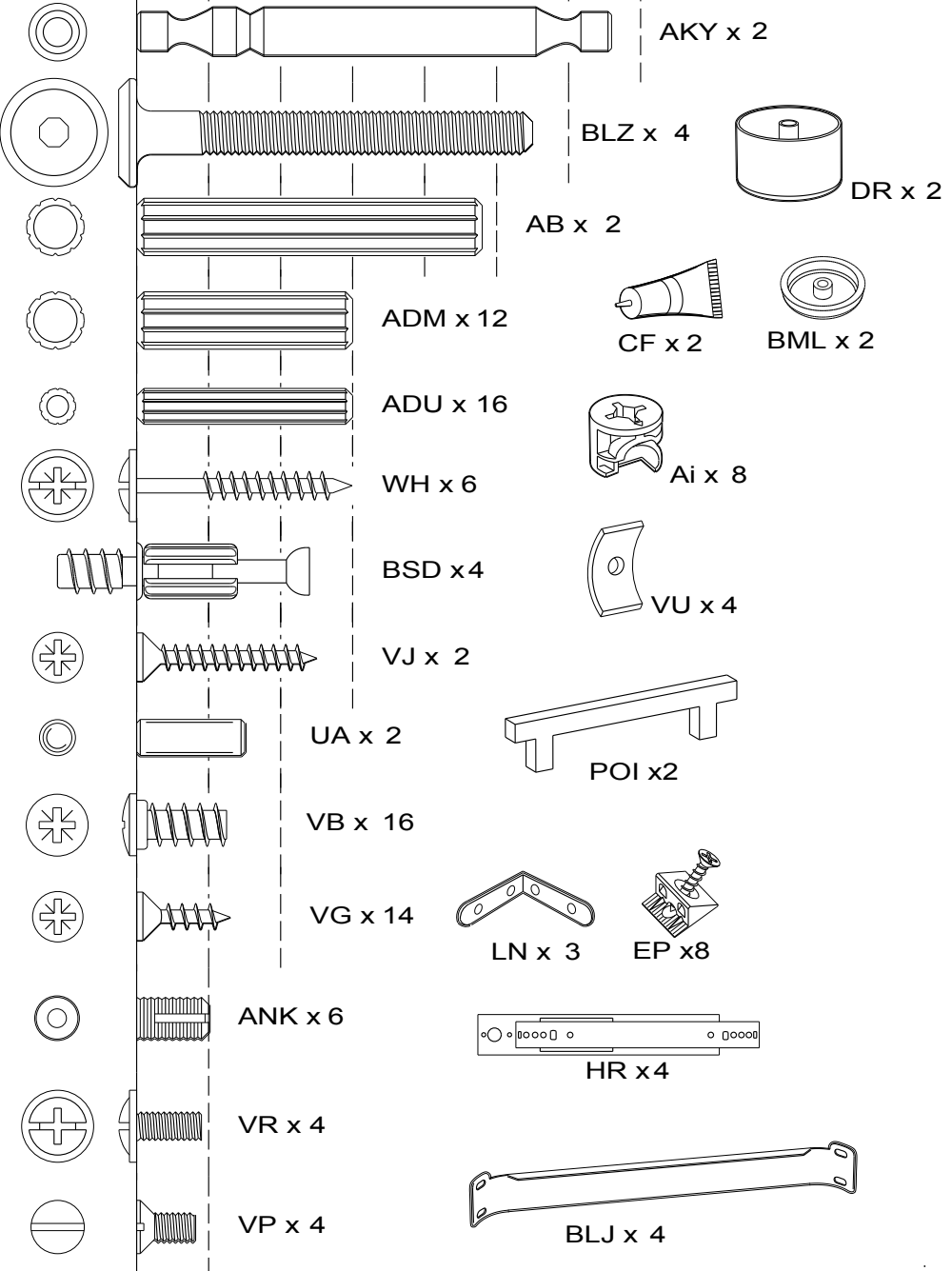
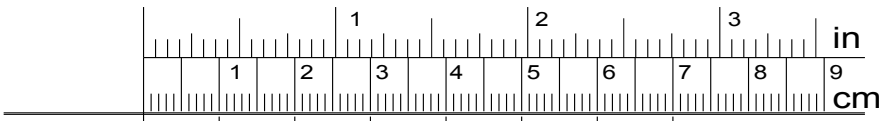

1

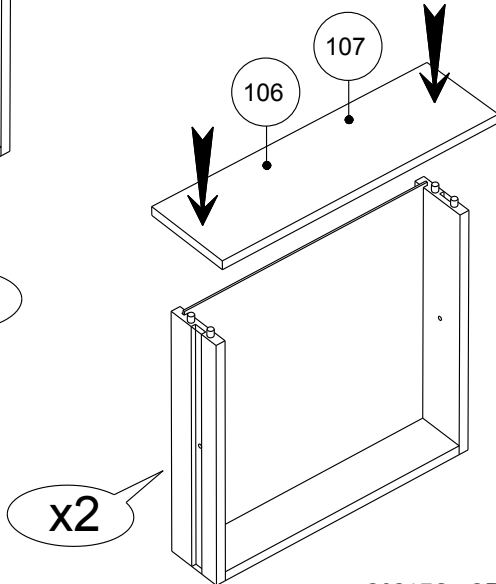
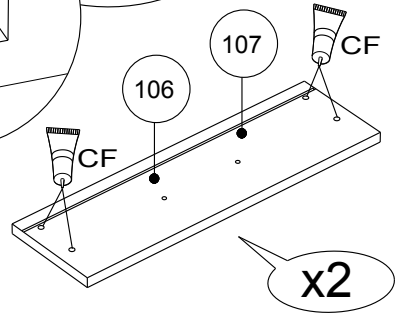
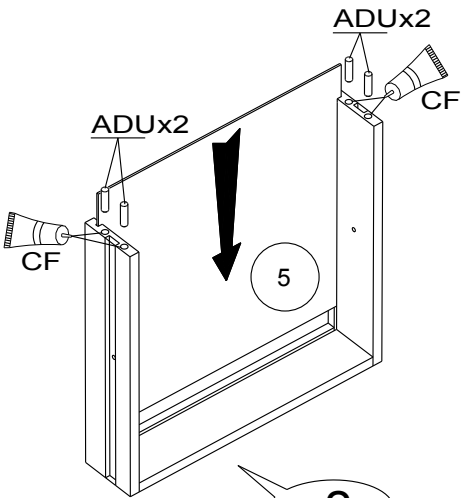
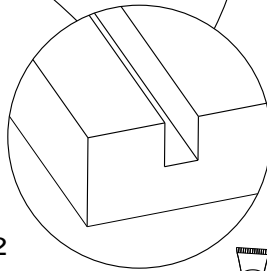
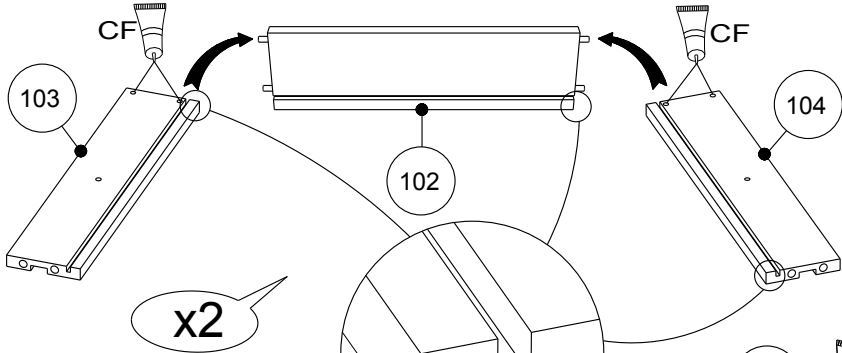
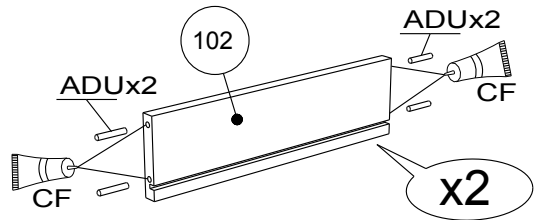

2

x2

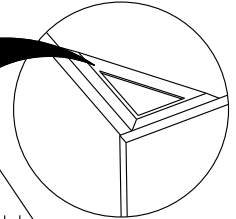
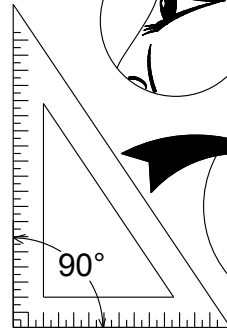
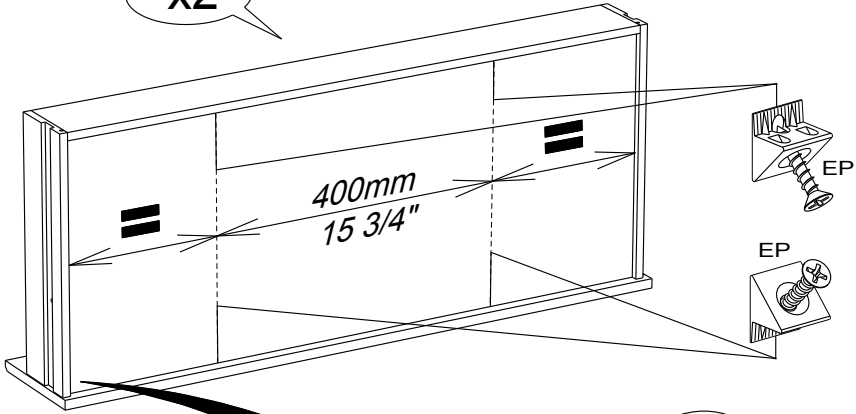

3

1

x2

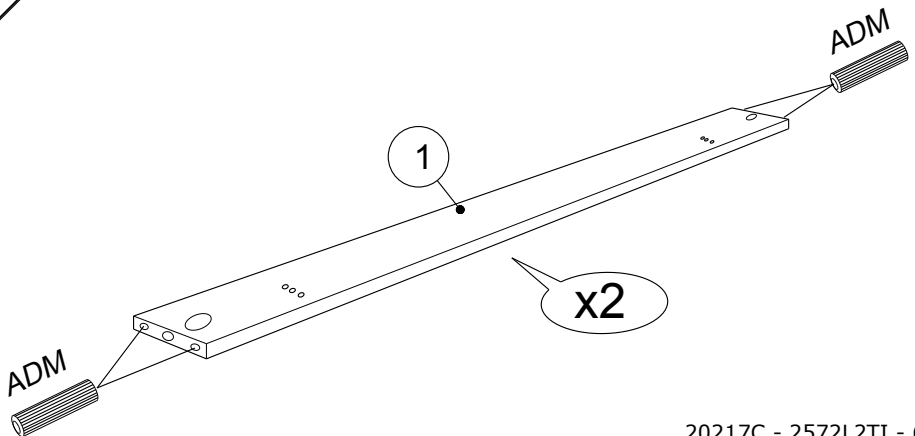

4

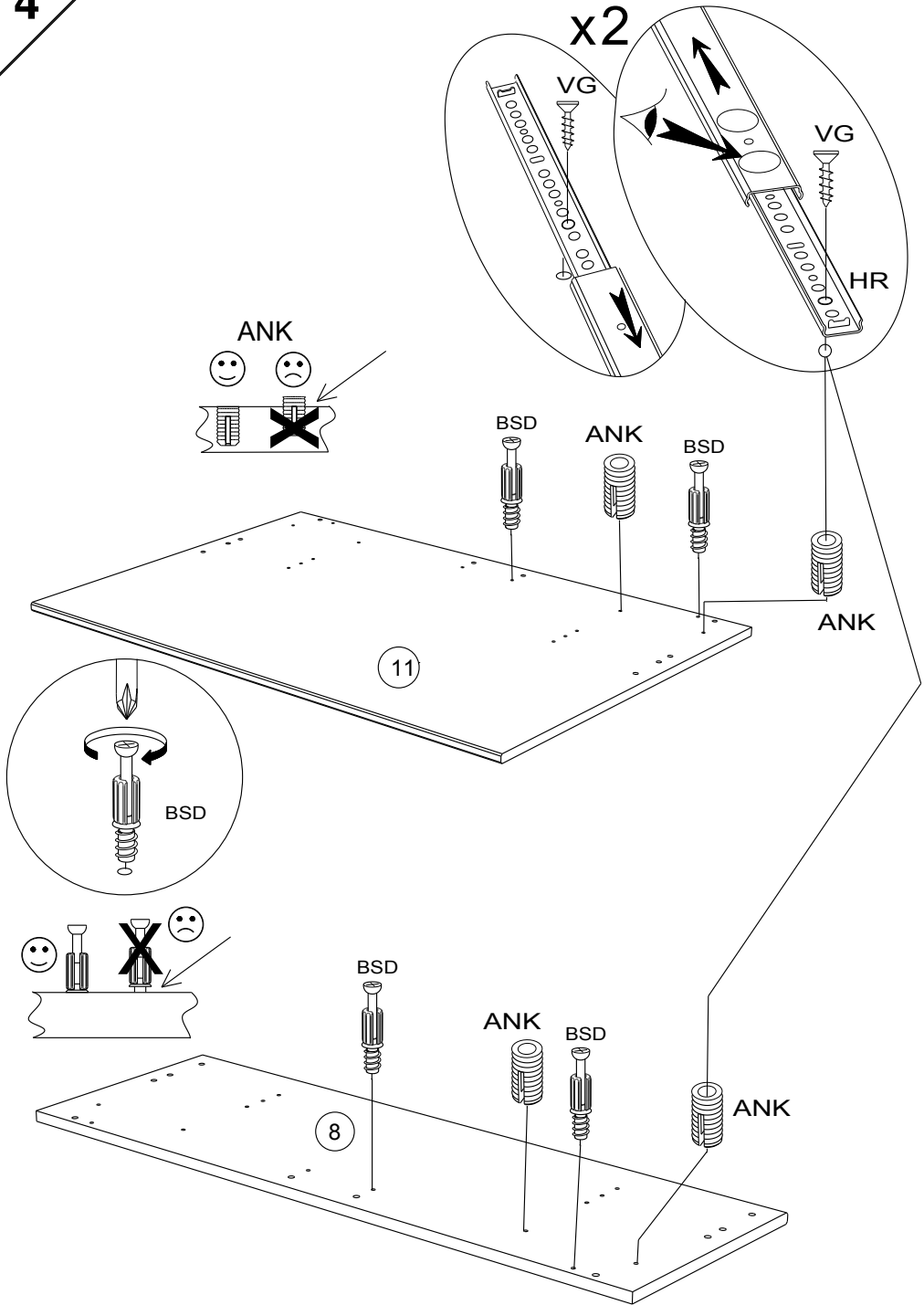

5

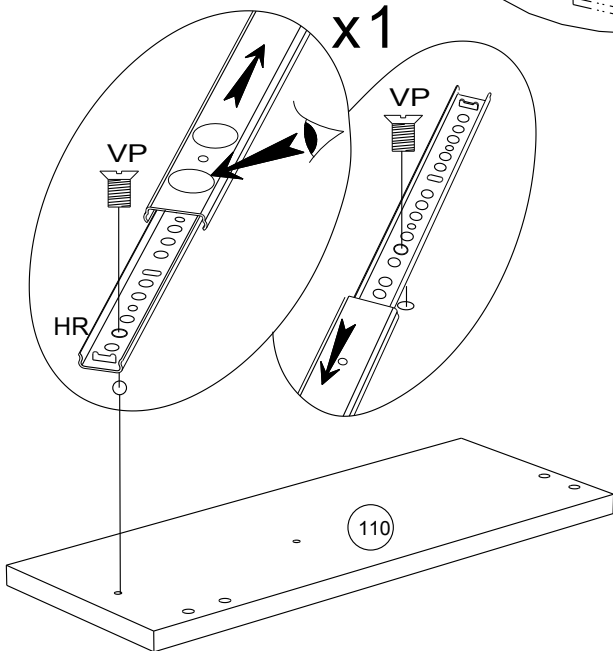
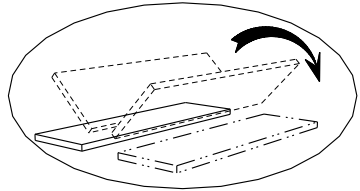
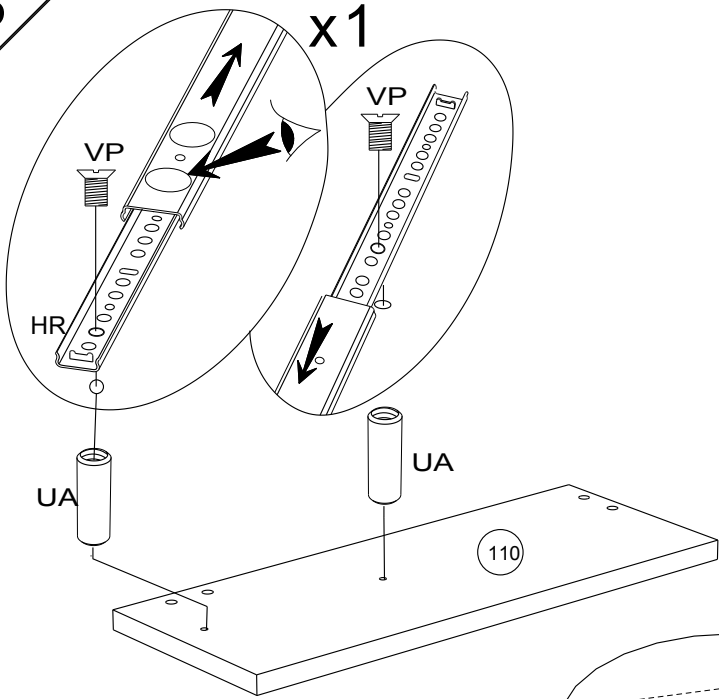

6

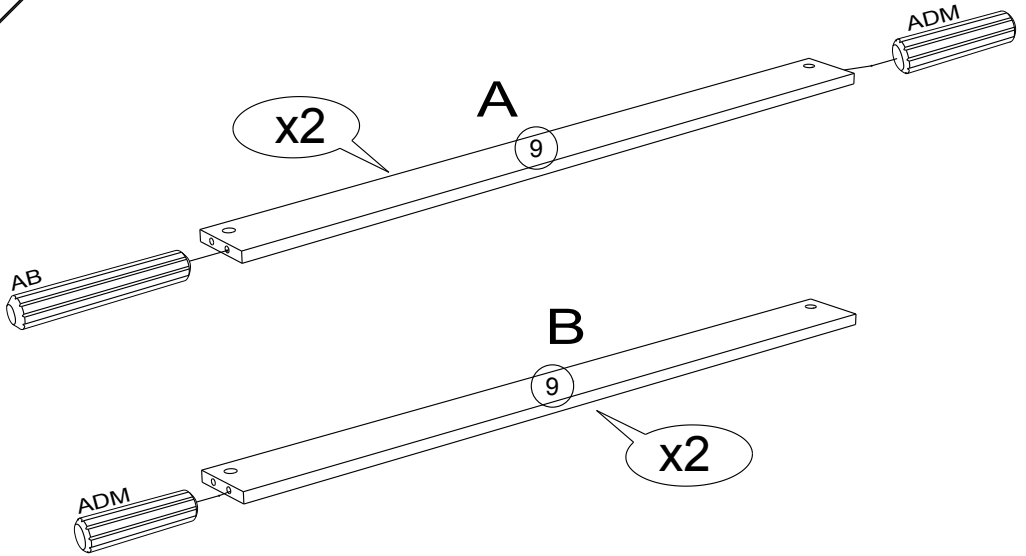

7

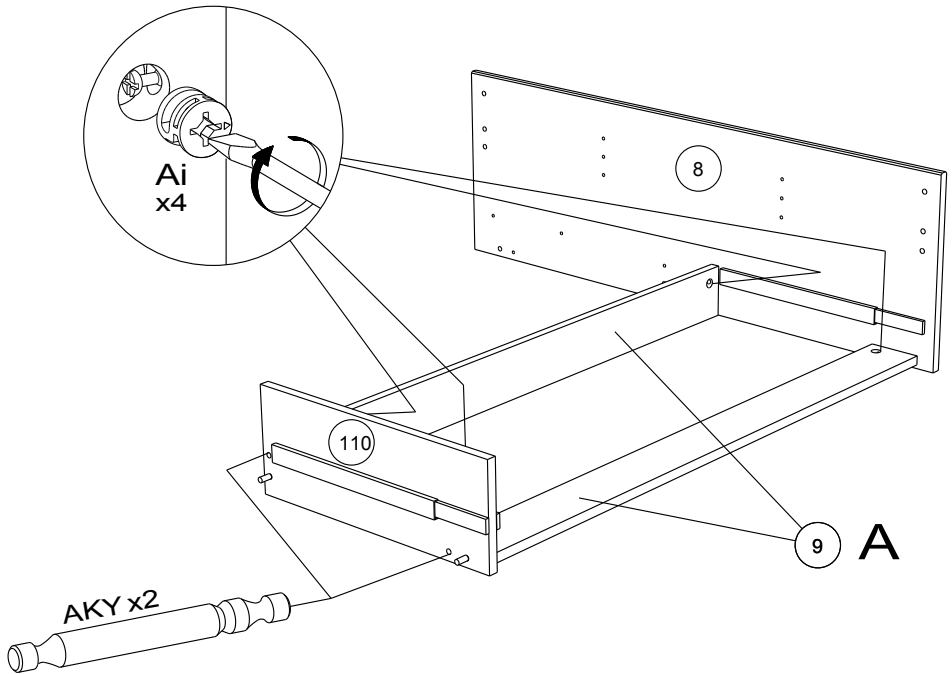

8

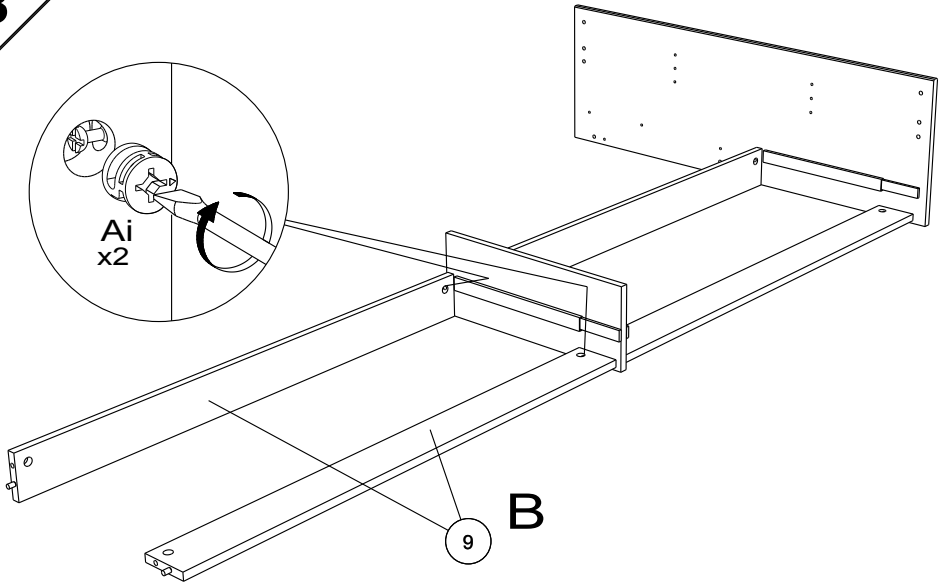

9

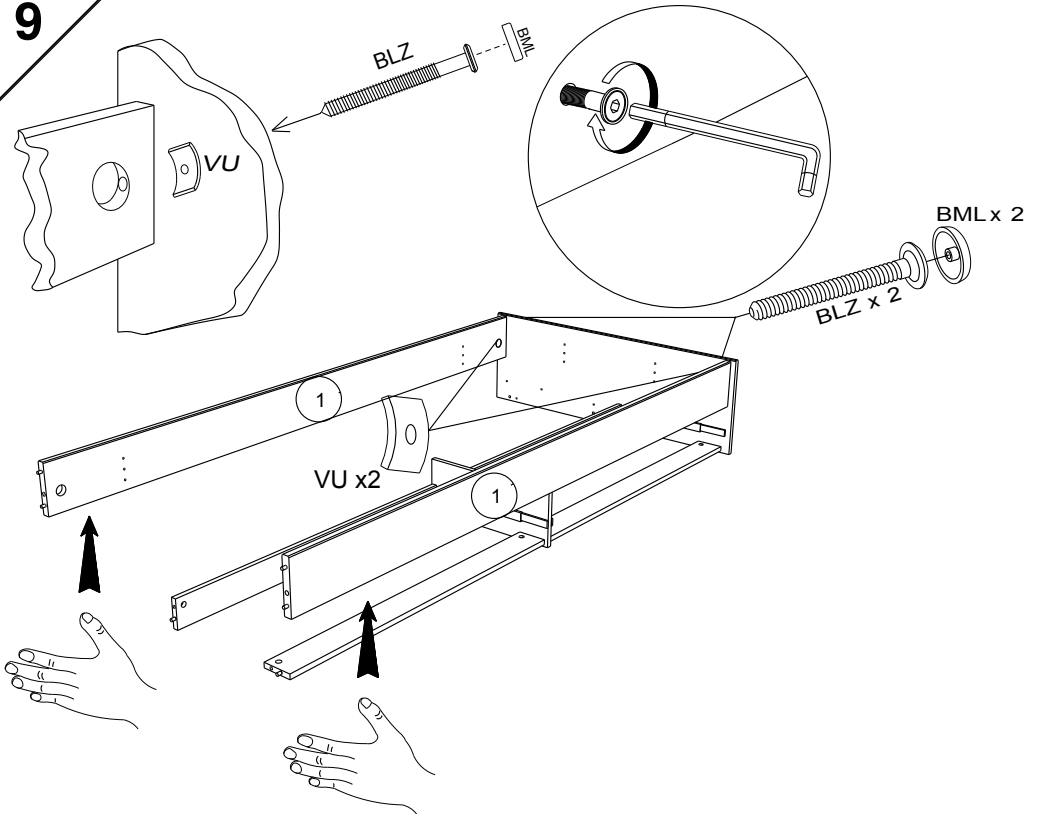

10

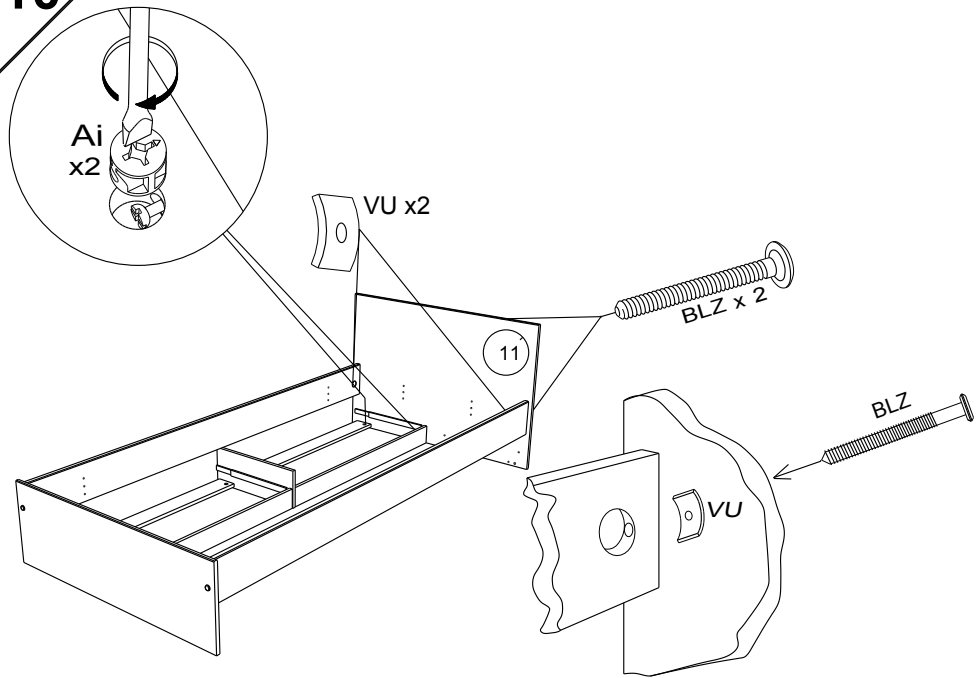

11

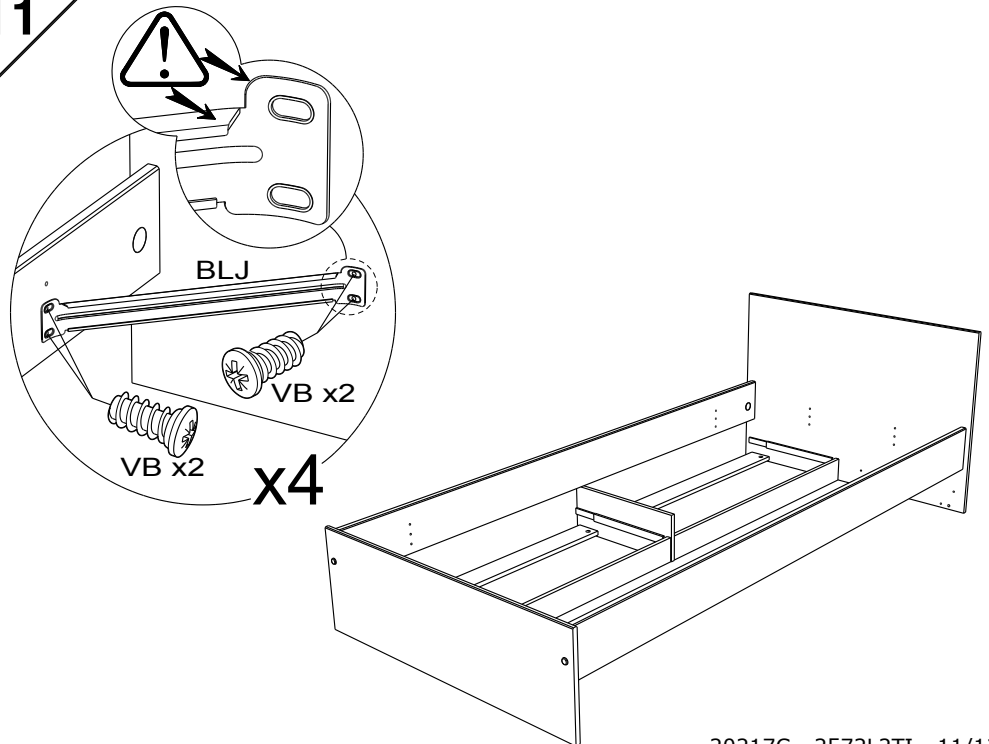

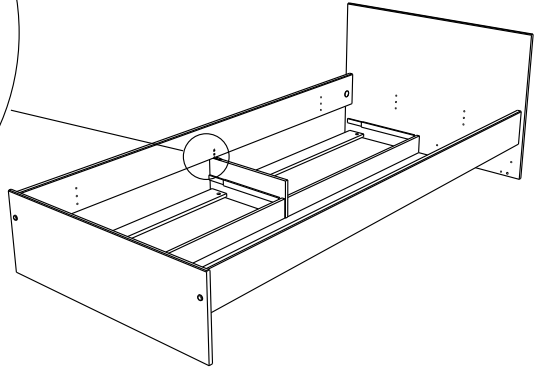
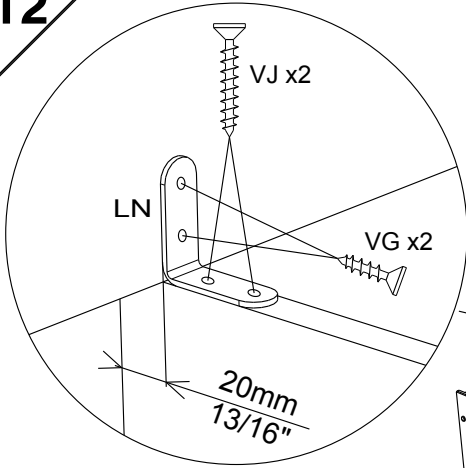
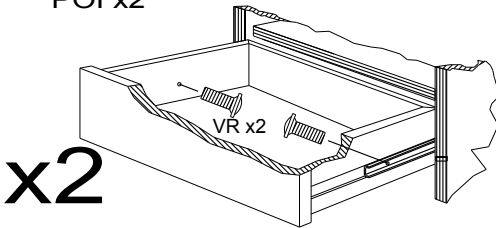
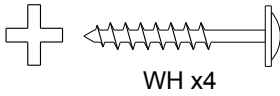
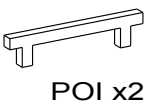
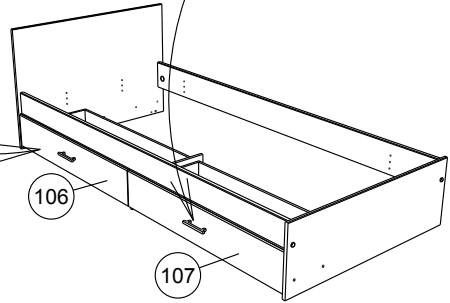
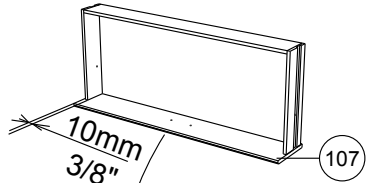
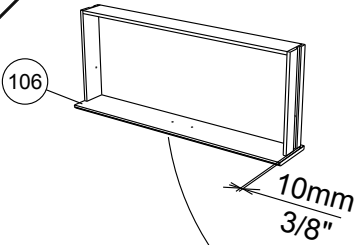
12**13**

14

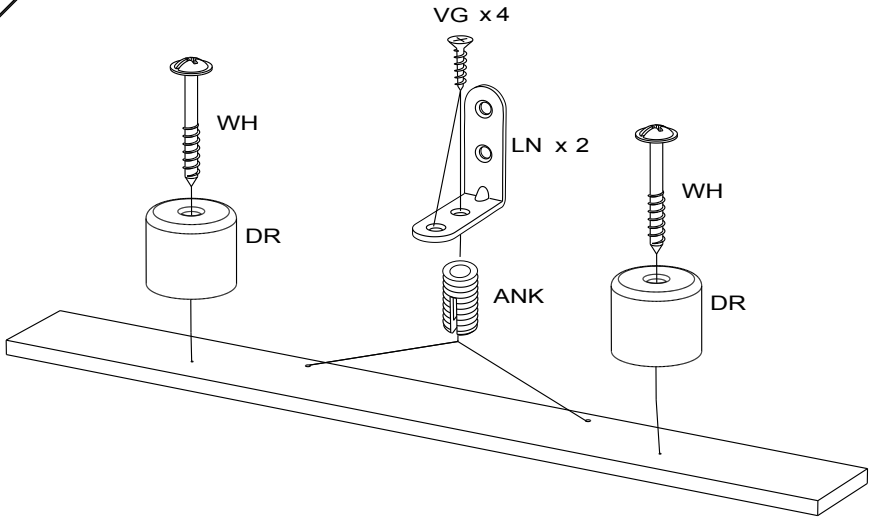

15

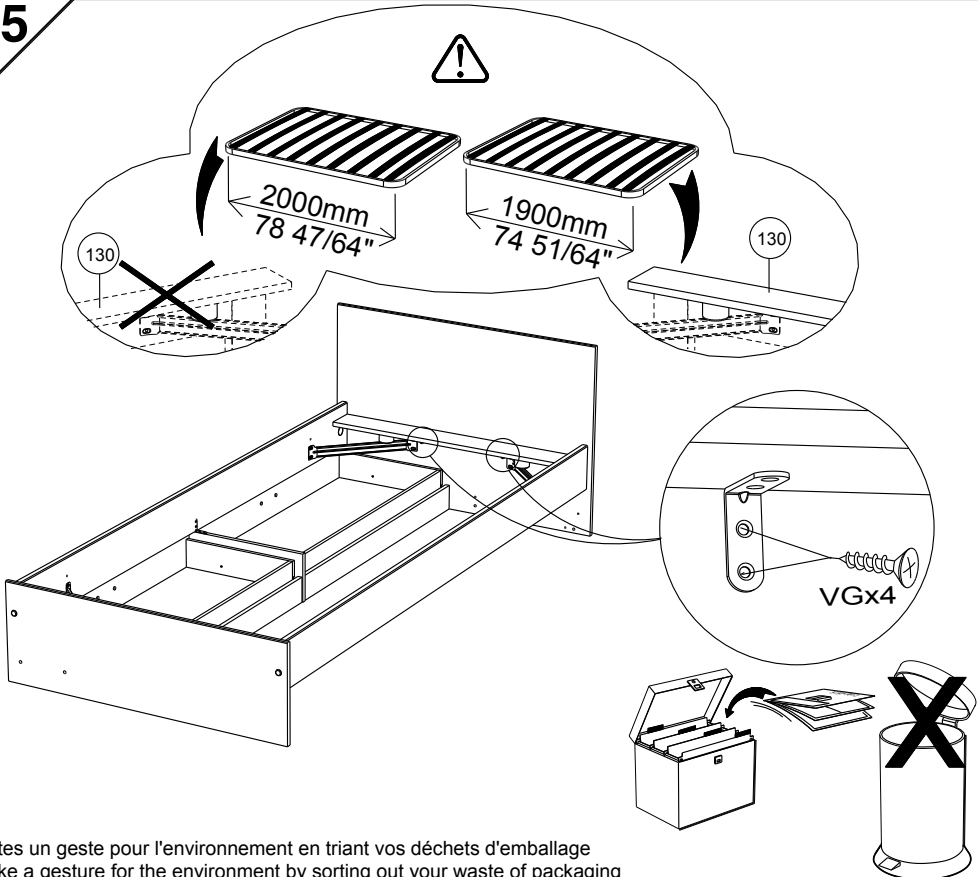

Faites un geste pour l'environnement en triant vos déchets d'emballage
 Make a gesture for the environment by sorting out your waste of packaging
 Machen Sie eine Bewegung für die Umwelt, ihre Verpackungsabfälle sortierend
 Haga un gesto para el medio ambiente escogiendo sus residuos de embalaje

2572L2TI

PARISOT INDUSTRIE 70800 SAINT LOUP SUR SEMOUSE -FRANCE-

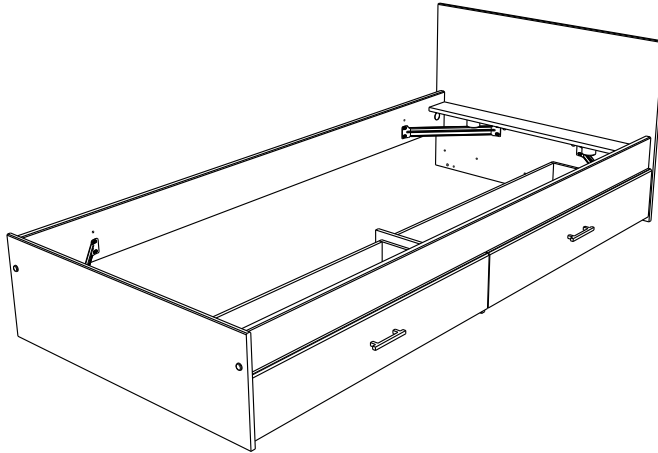

IMPORTANT KEEP FOR FUTURE REFERENCE

WARNING: NOT SUITABLE FOR CHILDREN UNDER 6 YEARS.

WARNING: DO NOT PLACE THIS CHILD'S BED NEAR HEAT SOURCES, WINDOWS AND OTHER FURNITURE.

WARNING: DO NOT USE THIS CHILD'S BED IF ANY PART IS BROKEN, TORN OR MISSING.

IMPORTANT : CONSERVER CETTE NOTICE POUR UTILISATION FUTURE

ATTENTION ! NE PAS UTILISER POUR ENFANTS DE MOINS DE 6 ANS.

ATTENTION ! NE PAS PLACER CE LIT ENFANT PRES DE SOURCES DE CHALEUR, DE FENETRES ET D'AUTRES MEUBLES.

ATTENTION ! NE PAS UTILISER CE LIT POUR ENFANT SI UNE PIECE EST CASSEE, DECHIREE OU MANQUANTE.

Gamme : SNOOP

FR Remerciements :

Nous vous remercions d'avoir choisi un meuble créé et fabriqué par le Groupe Parisot et espérons qu'il vous donnera entière satisfaction.

EN Thanks:

Thank you for choosing furniture designed and manufactured by the Parisot Group. We hope you are totally satisfied with your purchase.

DE Danksagung:

Wir danken Ihnen für den Kauf eines Frankreich von der Parisot-Gruppe entworfenen und hergestellten Möbelstücks und hoffen, dass Sie es zu Ihrer vollkommenen Zufriedenheit finden werden.

HU Köszönet:

Köszönjük, hogy a Parisot Groupe által létrehozott és gyártott bútort választott, reméljük, hogy elégedett lesz a termékkel.

PT Agradecimentos:

Obrigado por ter escolhido um móvel concebido e fabricado pelo Grupo Parisot, esperando que seja do seu inteiro agrado.

IT Ringraziamenti:

Grazie per avere scelto un mobile progettato e fabbricato dal Gruppo Parisot. Speriamo soddisfatti appieno le vostre esigenze.

NL Bedankje:

Wij bedanken u voor de aankoop van een door de Groep Parisot ontworpen en vervaardigd meubel en hopen dat u er veel plezier aan zult beleven.

CZ Poděkování:

Děkujeme, že jste si vybrali nábytek navrhnutý a vyrobený společností Parisot Group. Doufáme, že budete svým nákupem naprosto spokojeni.

ES Agradecimientos:

Les damos las gracias por haber elegido un mueble diseñado y fabricado por el Grupo Parisot y esperamos que sea de su total agrado.

PL Podziękowania:

Dziękujemy za wybór mebli stworzonych i wyprodukowanych przez Grupę Parisot. Mamy nadzieję, że będziecie Państwo w pełni zadowoleni z zakupu.

SK Pod'akovanie:

Ďakujeme, že ste si vybrali nábytok navrhnutý a vyrobený spoločnosťou Parisot Group. Dúfame, že budete svojim nákupom absolútne spokojní.

AR شكر:

نشكركم لاختياركم هذه القطعة من الأثاث من تصميم وتصنيع مجموعة باريسو Parisot ونتمنى أن تنال رضائكم.

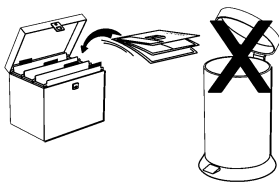

FR

Donnez ou recyclez vos meubles.



ou



ou



Association

Magasin

Déchèterie

<https://quefairedemesdechets.fr>

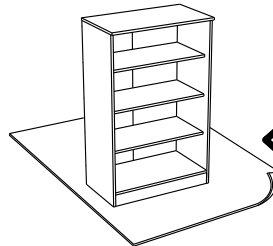
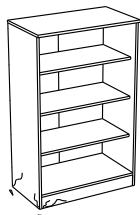
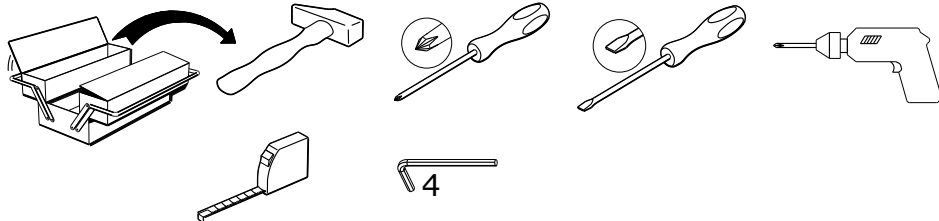

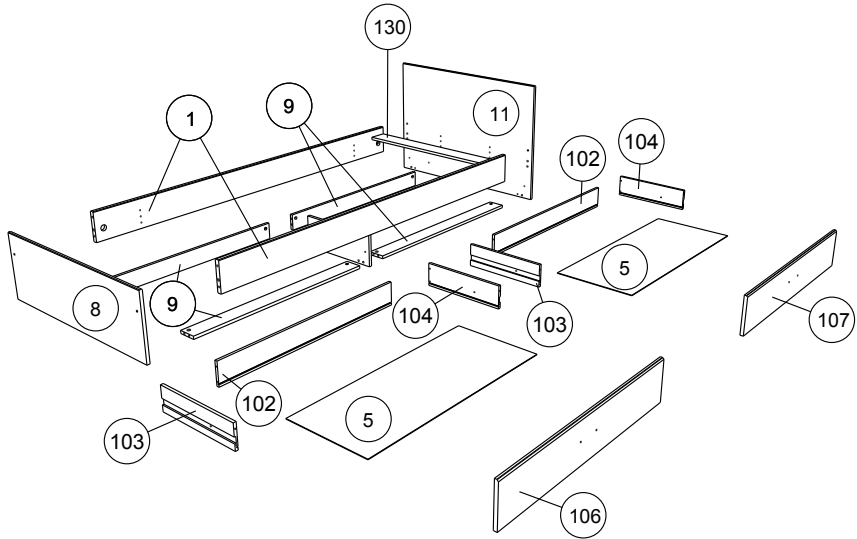
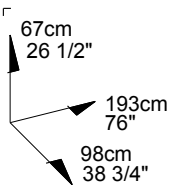



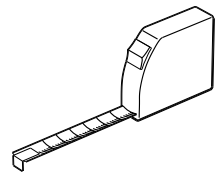

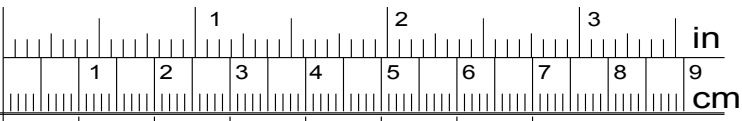

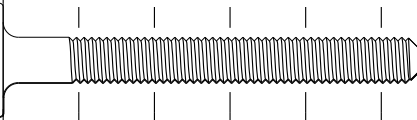
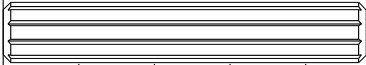
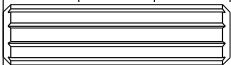

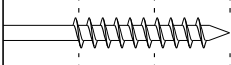
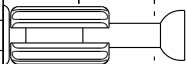
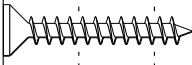

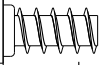
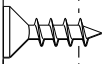



		mm			inch		
130	x 1	900	100	15	35 7/16	3 15/16	9/16
8	x 1	980	326	15	38 9/16	12 13/16	9/16
11	x 1	980	669	15	38 9/16	26 5/16	9/16
9	x 4	993	86	15	39 1/16	3 3/8	9/16
106	x 1	996	183	15	39 3/16	7 3/16	9/16
107	x 1	996	183	15	39 3/16	7 3/16	9/16
1	x 2	2000	155	22	78 3/4	6 1/8	7/8
104	x 2	400	110	13	15 3/4	4 5/16	1/2
103	x 2	400	110	13	15 3/4	4 5/16	1/2
102	x 2	960	110	13	37 3/4	4 5/16	1/2
5	x 2	971	399	3	38 3/16	15 11/16	1/8

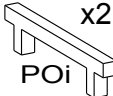
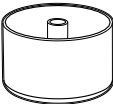

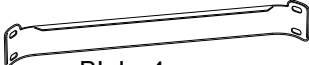
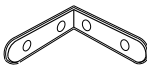

- 
AKY x 2
- 
BLZ x 4
- 
AB x 2
- 
ADM x 12
- 
ADU x 16
- 
WH x 6
- 
BSD x 4
- 
VJ x 2
- 
UA x 2
- 
VB x 16
- 
VG x 14
- 
ANK x 6
- 
VR x 4
- 
VP x 4
- 
CF x 2
- 
Ai x 8
- 
VU x 4
- 
x2
POi
- 
DR x 2
- 
BML x 2
- 
EP x 8
- 
HR x 4
- 
BLJ x 4
- 
LN x 3

1

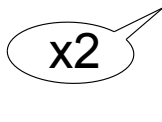
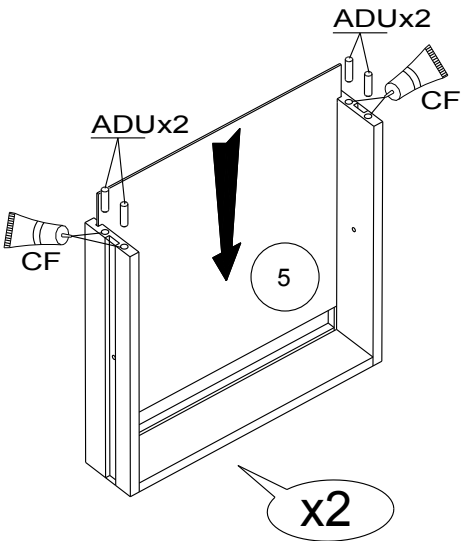
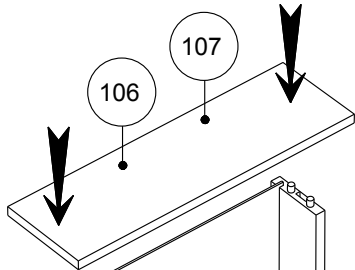
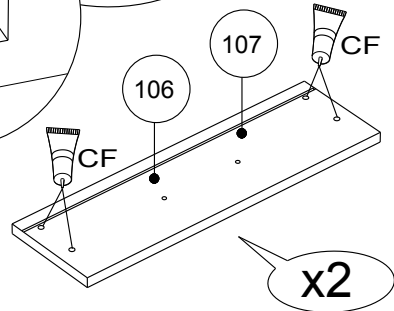
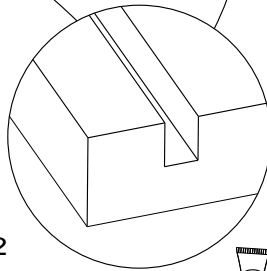
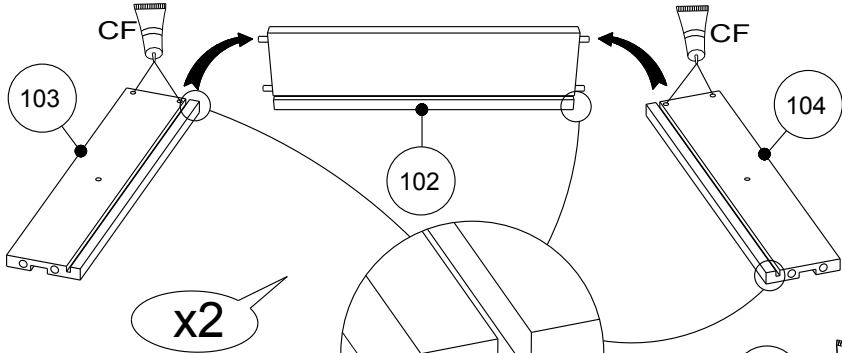
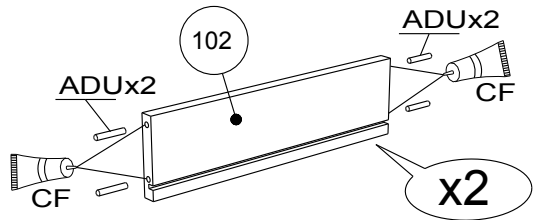

2

x2

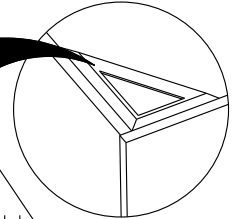
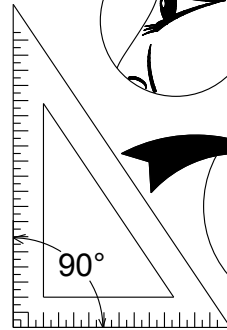
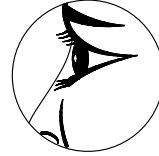
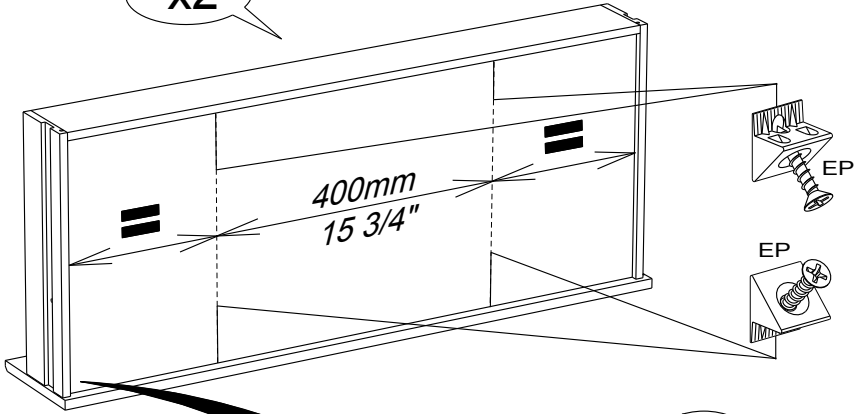

3

1

x2

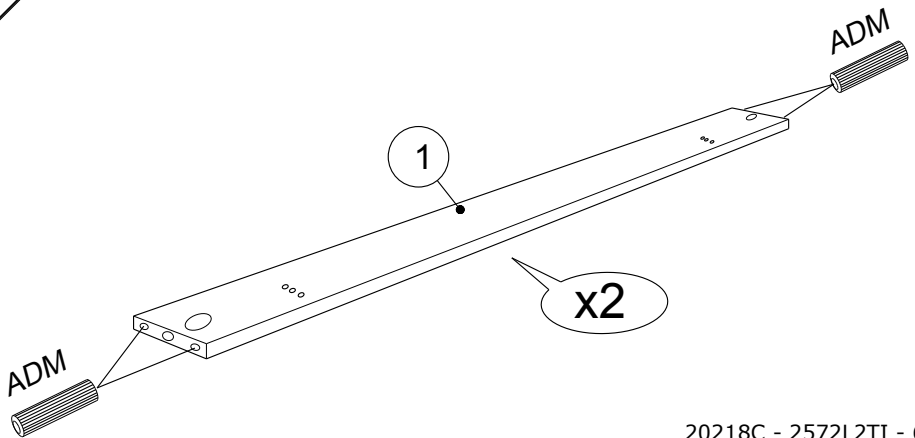

4

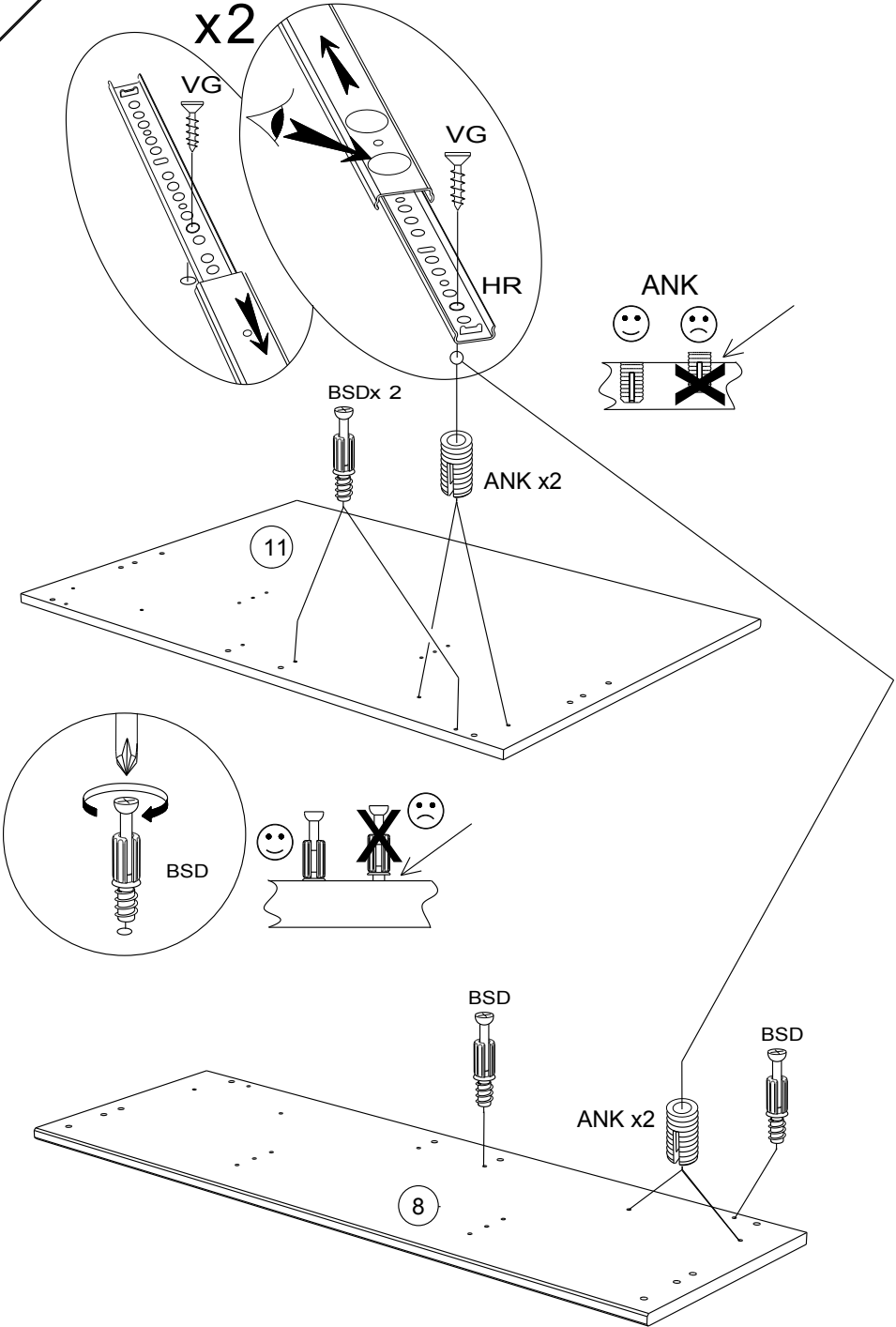

5

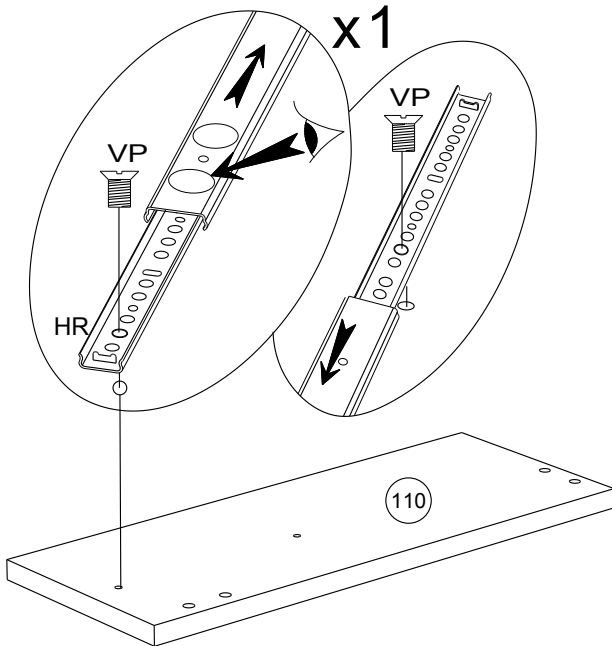
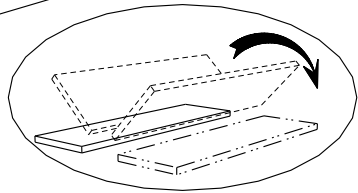
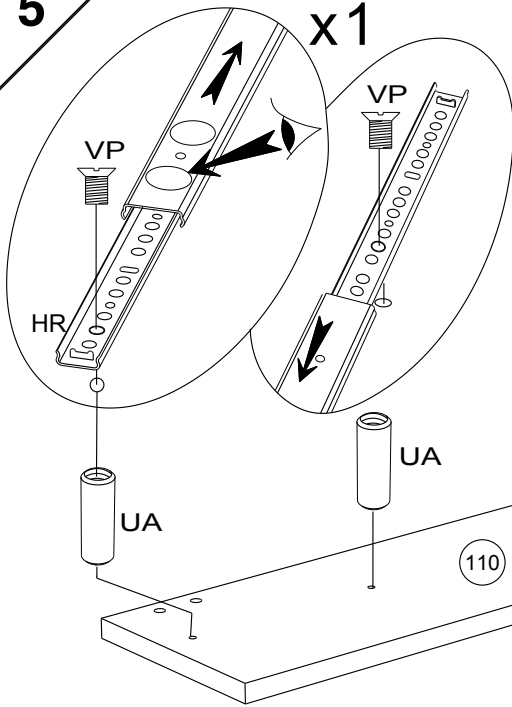

6

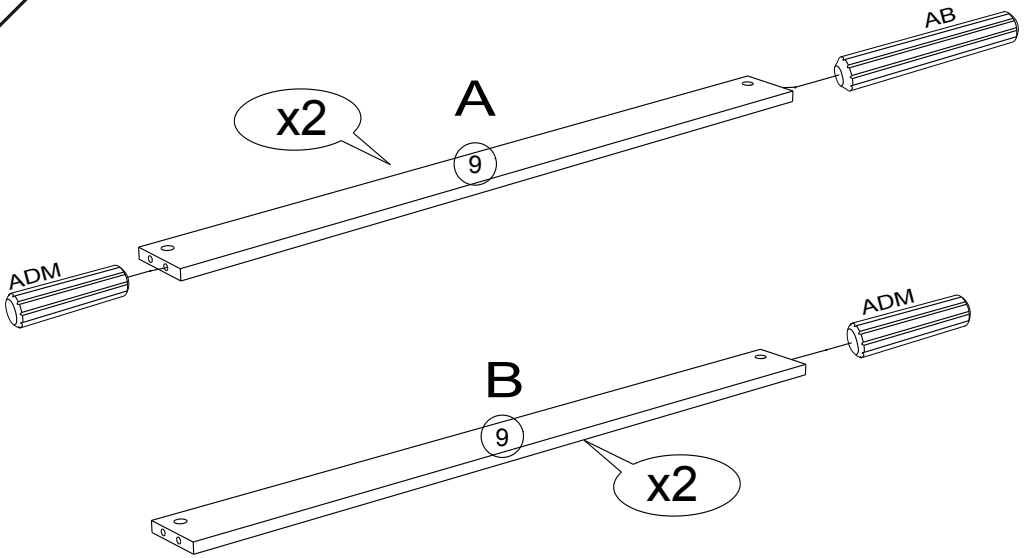

7

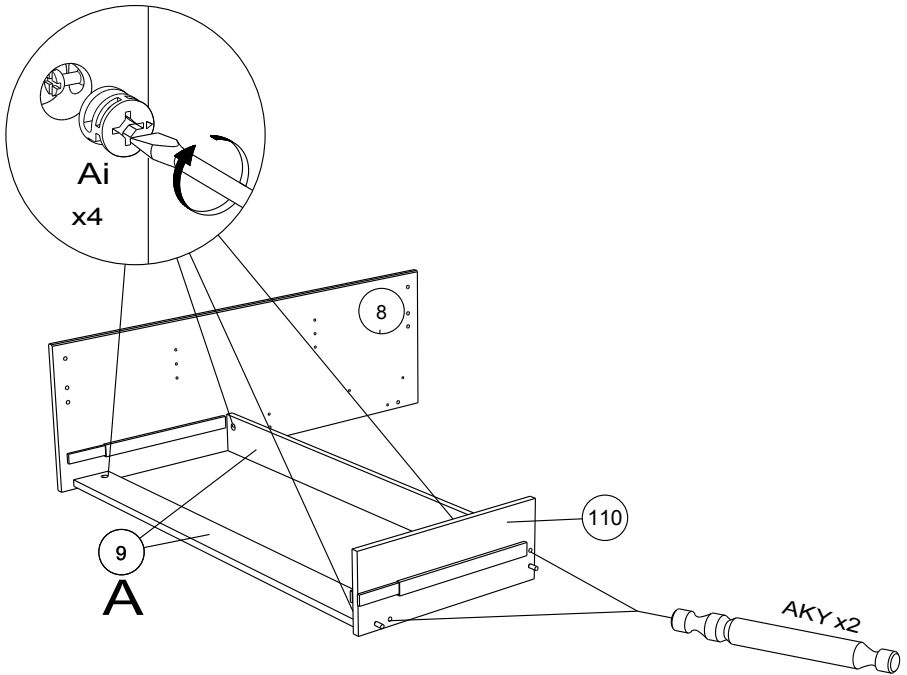

8

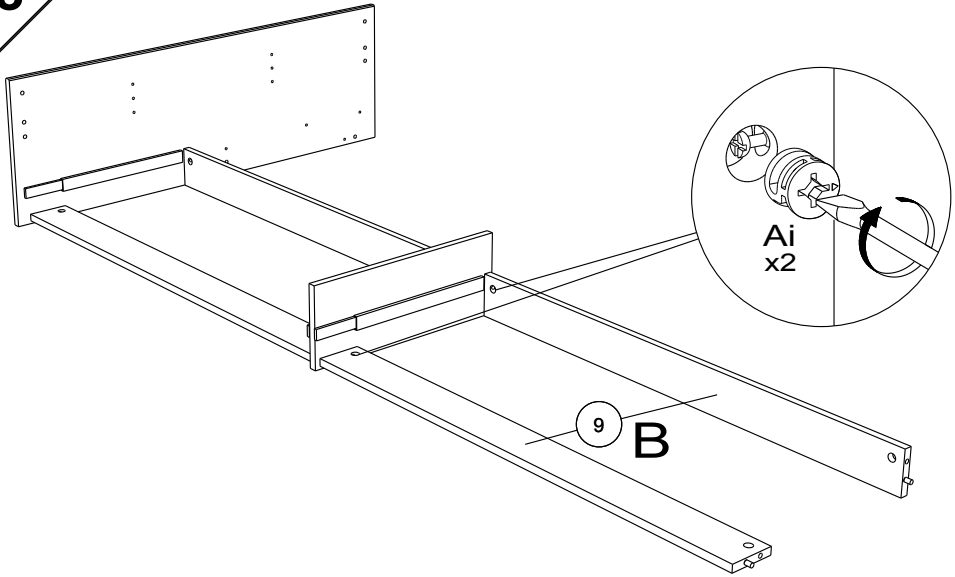

9

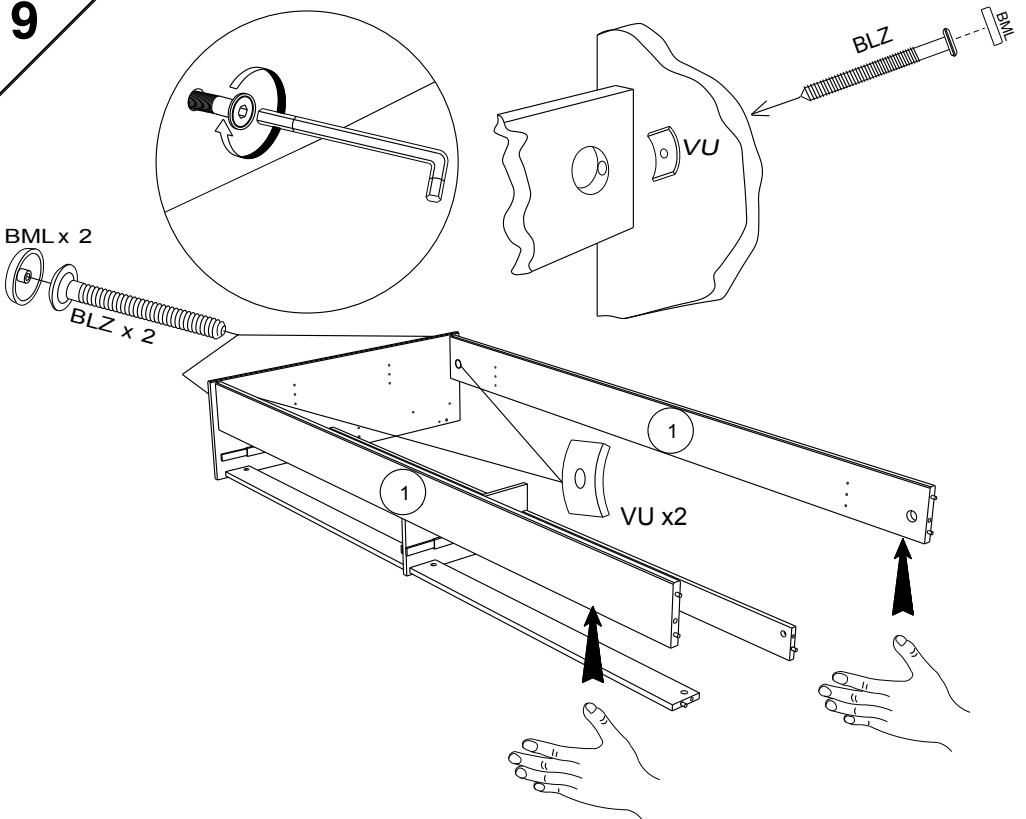

10

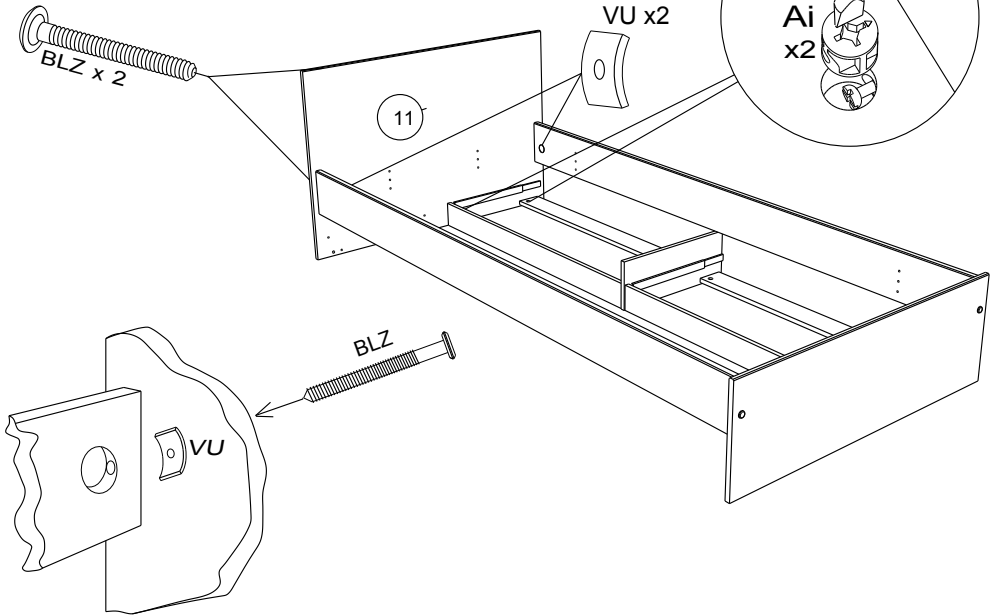

11

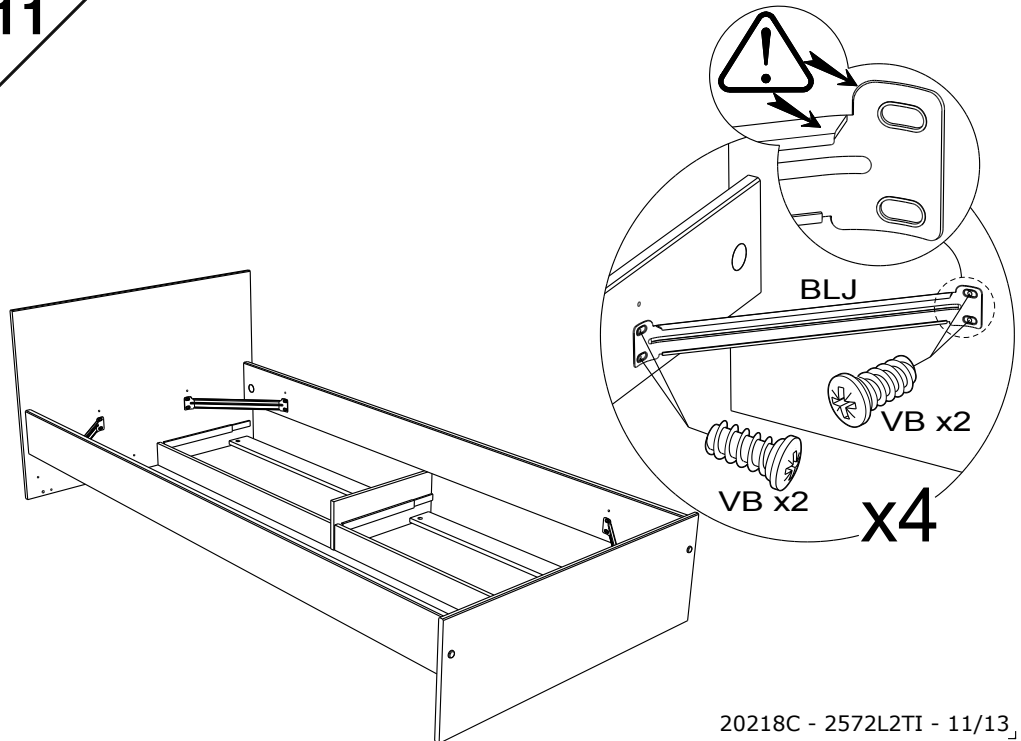

12

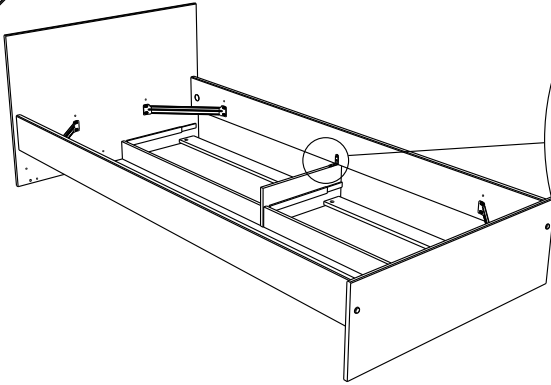

VJ x2

VG x2

LN

20mm
13/16"

13

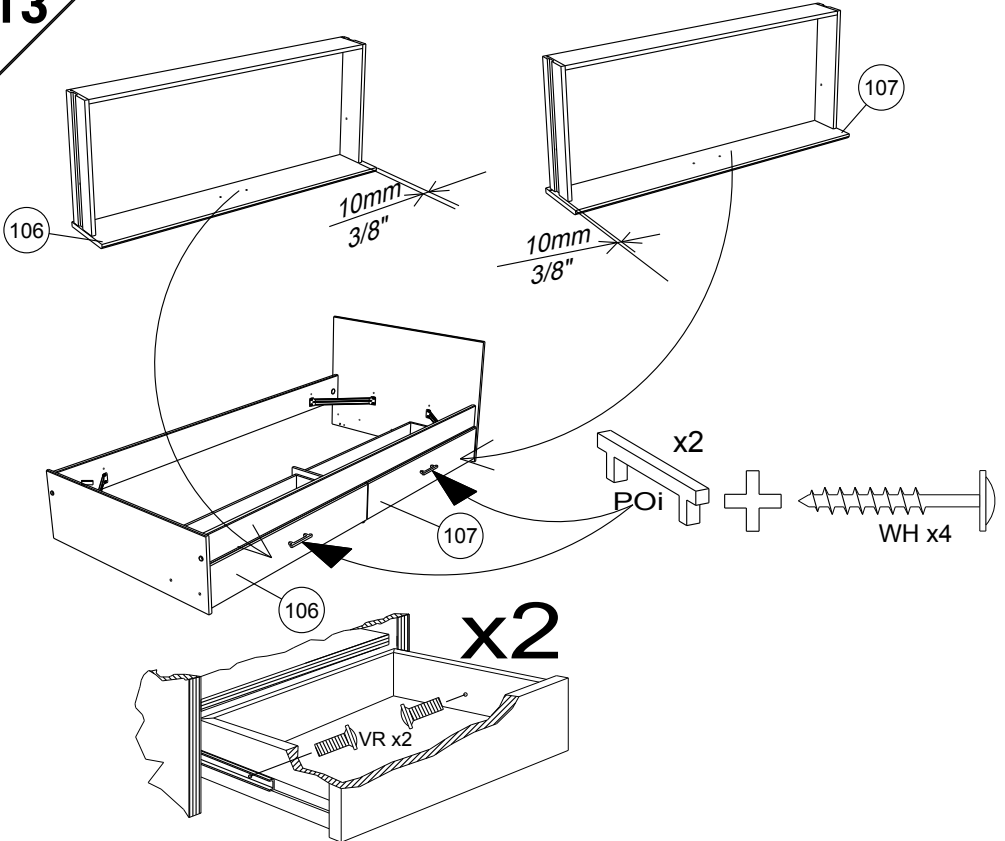

106

10mm
3/8"

107

10mm
3/8"

107

x2

POi

WH x4

106

x2

VR x2

14

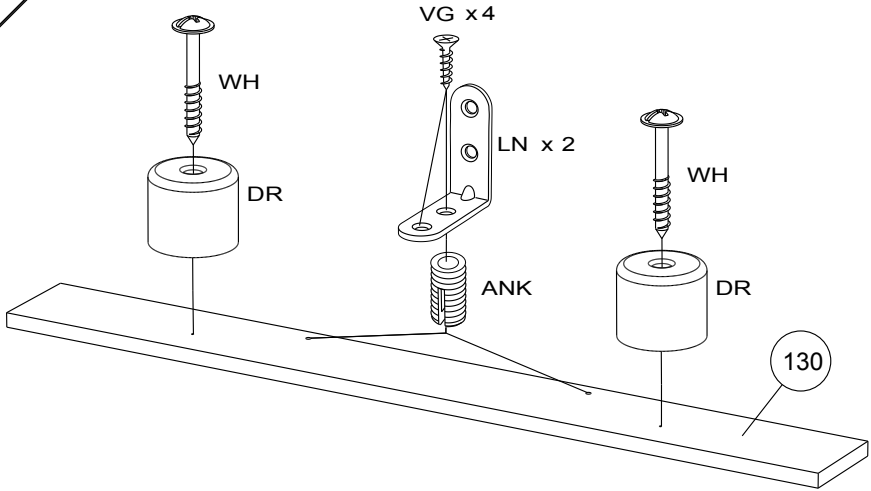

15

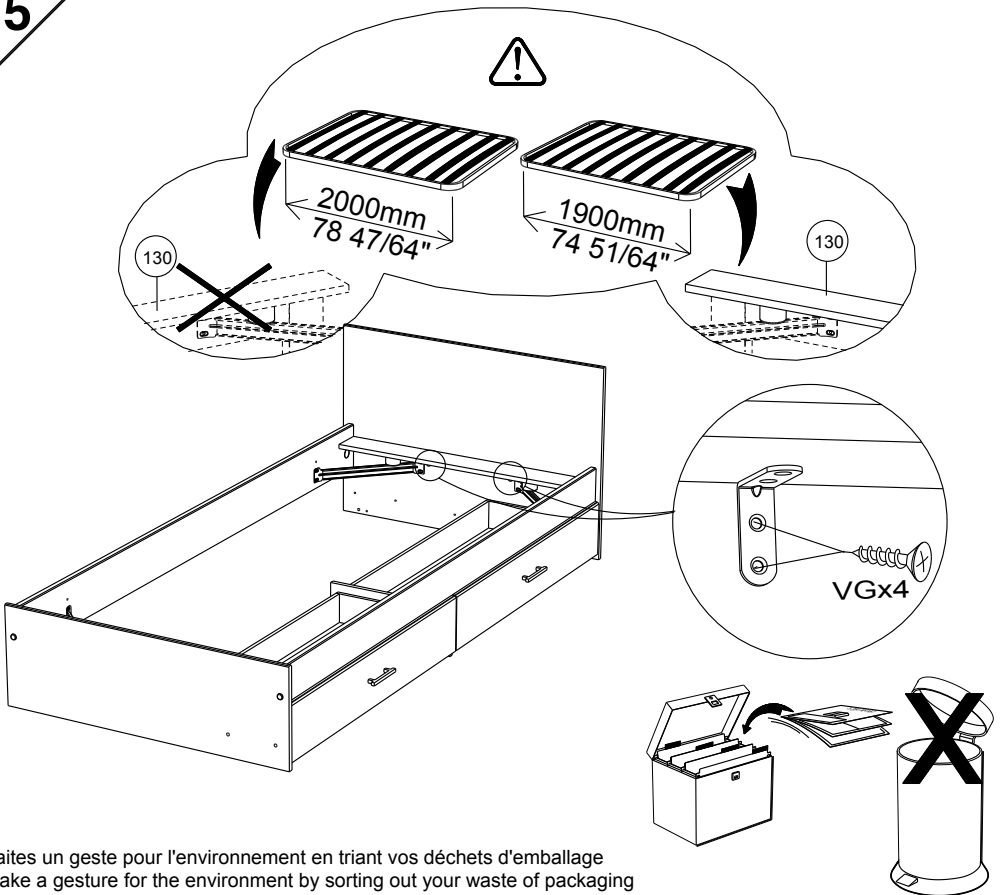

Faites un geste pour l'environnement en triant vos déchets d'emballage
 Make a gesture for the environment by sorting out your waste of packaging
 Machen Sie eine Bewegung für die Umwelt, ihre Verpackungsabfälle sortierend
 Haga un gesto para el medio ambiente escogiendo sus residuos de embalaje

2572ENVI

PARISOT INDUSTRIE 70800 SAINT LOUP SUR SEMOUSE -FRANCE-

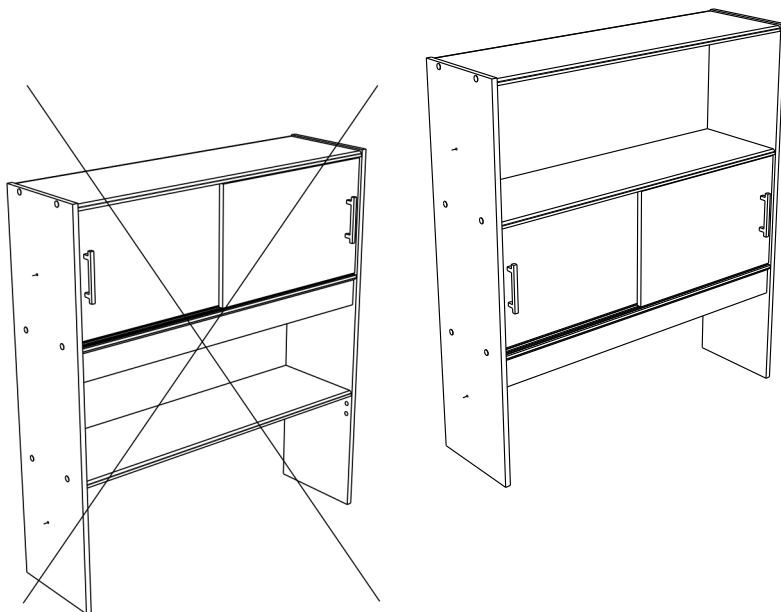

FR

Donnez ou recyclez
 vos meubles.



ou



ou



Association

Magasin

Déchèterie

<https://quefairedemesdechets.fr>



PARISOT INDUSTRIE

FR Remerciements :

Nous vous remercions d'avoir choisi un meuble créé et fabriqué par le Groupe Pariset et espérons qu'il vous donnera entière satisfaction.

EN Thanks:

Thank you for choosing furniture designed and manufactured by the Pariset Group. We hope you are totally satisfied with your purchase.

DE Danksagung:

Wir danken Ihnen für den Kauf eines Frankreich von der Pariset-Gruppe entworfenen und hergestellten Möbelstücks und hoffen, dass Sie es zu Ihrer vollkommenen Zufriedenheit finden werden.

ES Agradecimientos:

Les damos las gracias por haber elegido un mueble diseñado y fabricado por el Groupe Pariset y esperamos que sea de su total agrado.

PT Agradecimentos:

Obrigado por ter escolhido um móvel concebido e fabricado pelo Grupo Pariset, esperando que seja do seu inteiro agrado.

IT Ringraziamenti:

Grazie per avere scelto un mobile progettato e fabbricato dal Gruppo Pariset. Speriamo soddisfi appieno le vostre esigenze.

NL Bedankje:

Wij bedanken u voor de aankoop van een door de Groep Pariset ontworpen en vervaardigd meubel en hopen dat u er veel plezier aan zult beleven.

CZ Poděkování:

Děkujeme, že jste si vybrali nábytek navržený a vyrobený společností Pariset Group. Doufáme, že budete svým nákupem naprosto spokojeni.

HU Köszönet.

Köszönjük, hogy a Pariset Groupe által létrehozott és gyártott bútort választott, reméljük, hogy elégedett lesz a termékkel.

PL Podziękowania:

Dziękujemy za wybór mebli stworzonych i wyprodukowanych przez Grupę Pariset. Mamy nadzieję, że będziecie Państwo w pełni zadowoleni z zakupu.

RO Mulțumiri:

Vă mulțumim că ați ales un articol de mobilier conceput și fabricat de Grupul Pariset și sperăm că veți fi pe deplin satisfăcuți de acesta.

RU Благодарность:

Мы благодарим вас за то, что вы выбрали мебель, созданную и произведенную Групп Парисо, и надеемся, что вы будете полностью удовлетворены нашей продукцией.

SK Pod'akovanie:

Ďakujeme, že ste si vybrali nábytok navrhnutý a vyrobený spoločnosťou Pariset Group. Dúfame, že budete svojim nákupom absolútne spokojní.

TR Teşekkür ederiz:

Pariset Group tarafından tasarlanan ve üretilen bu mobilyayı seçtiğiniz için teşekkür ederiz. Ürünümüzden memnun kalmanızı ümit ederiz.

AR : شكر

نشكركم لاختياركم هذه القطعة من الأثاث من تصميم وتصنيع مجموعة باريزو Pariset ونتمنى أن تال رضاهم.

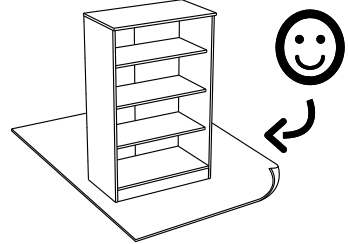
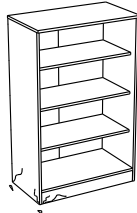
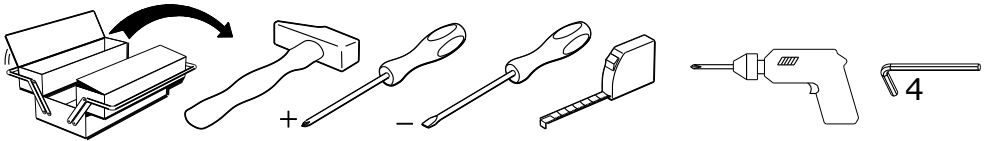

contact@pariset.com



www.pariset.com

108cm
42 3/4"
98cm
38 3/4"
28.5cm
11 1/4"

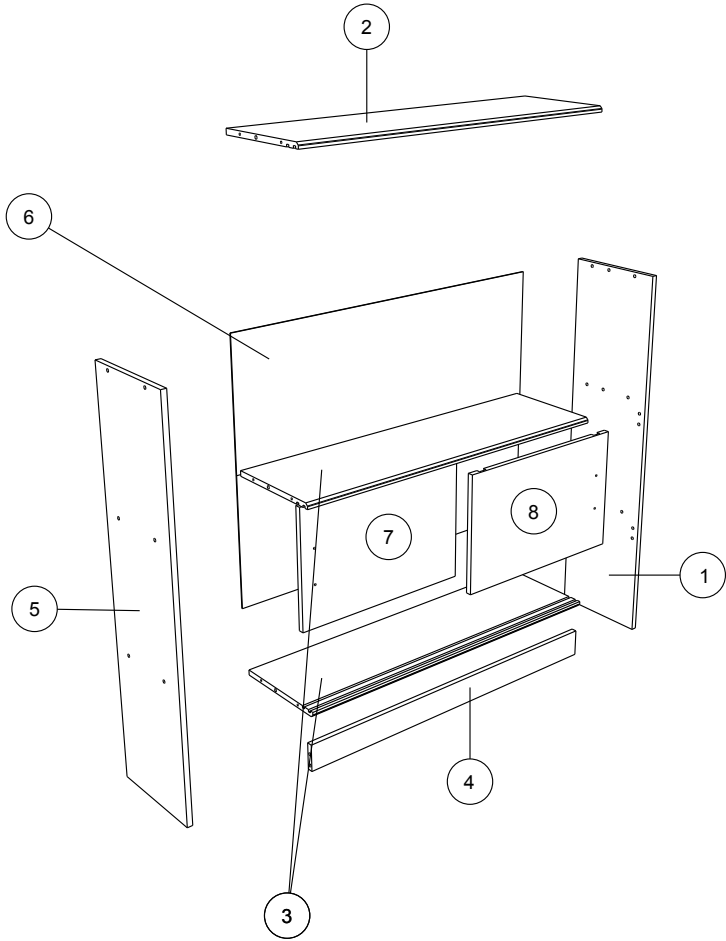

		mm			inch		
7	x 1	496	330	15	19 1/2	13	9/16
8	x 1	496	330	15	19 1/2	13	9/16
4	x 1	948	76	15	37 5/16	3	9/16
2	x 1	948	278	15	37 5/16	10 15/16	9/16
3	x 2	948	278	15	37 5/16	10 15/16	9/16
1	x 1	1080	280	15	42 1/2	11	9/16
5	x 1	1080	280	15	42 1/2	11	9/16
6	x 1	972	729	3	38 1/4	28 11/16	1/8

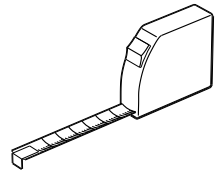

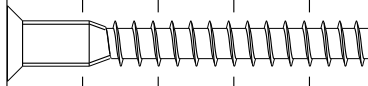
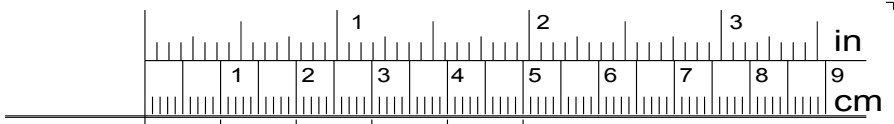

HW x 12

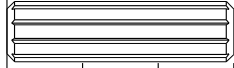

ADM x 10

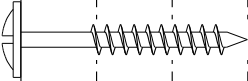

WH x 7

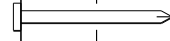

YB x 20

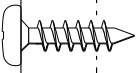

VE x 13

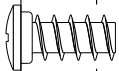

VB x 1

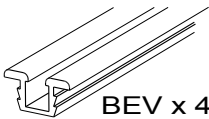

BEV x 4

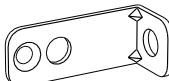

BLL x 2

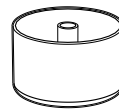

DR x 1



ZF x 4



WA x 12



POI x 2

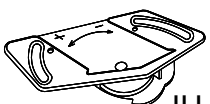

IU x 4

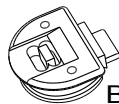

BAV x 4

1

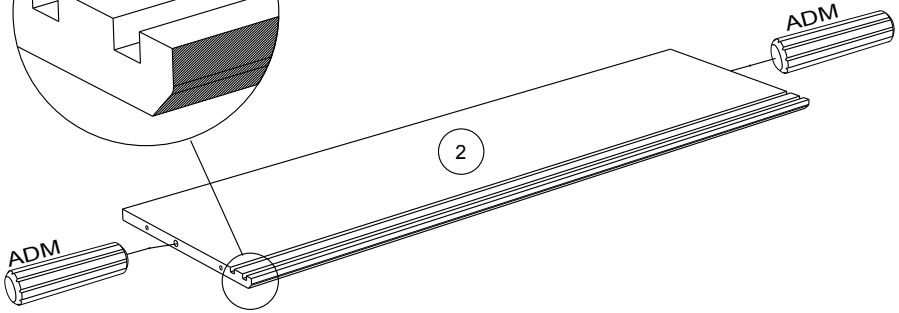
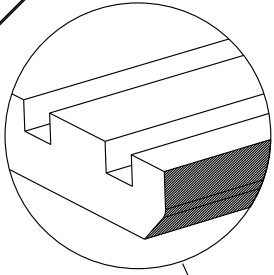

2

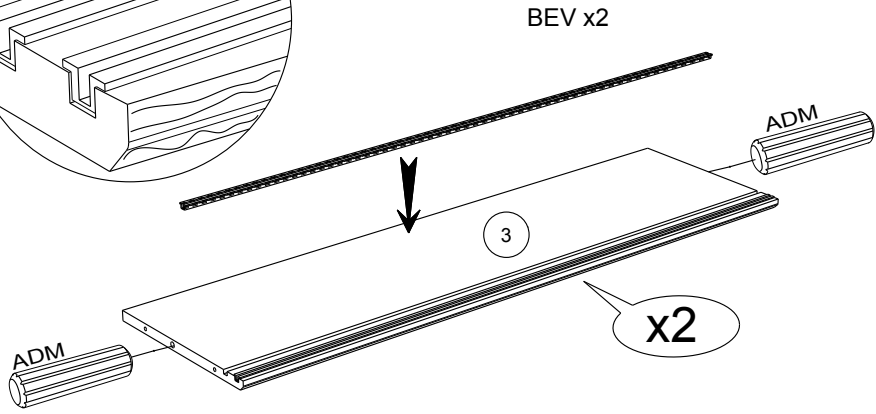
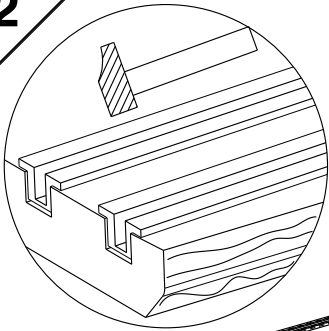

3

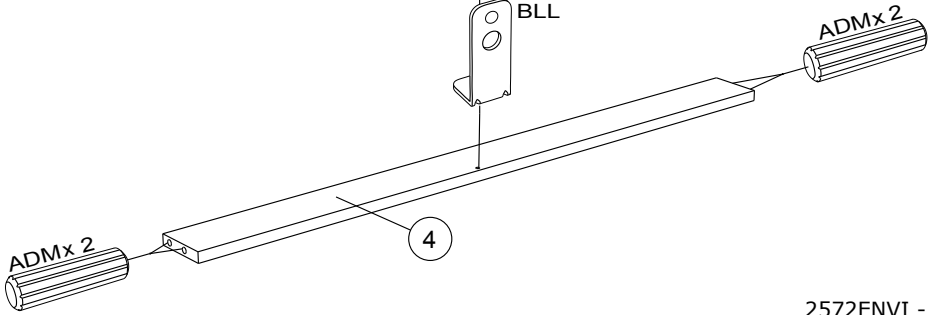
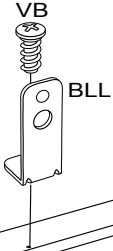

4

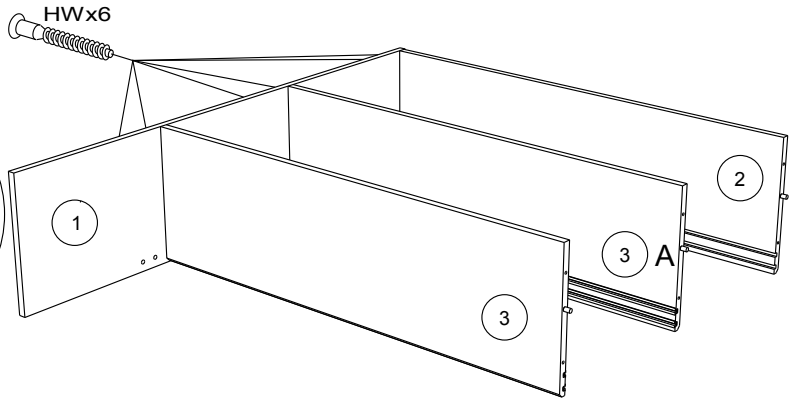
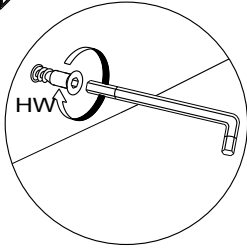

5

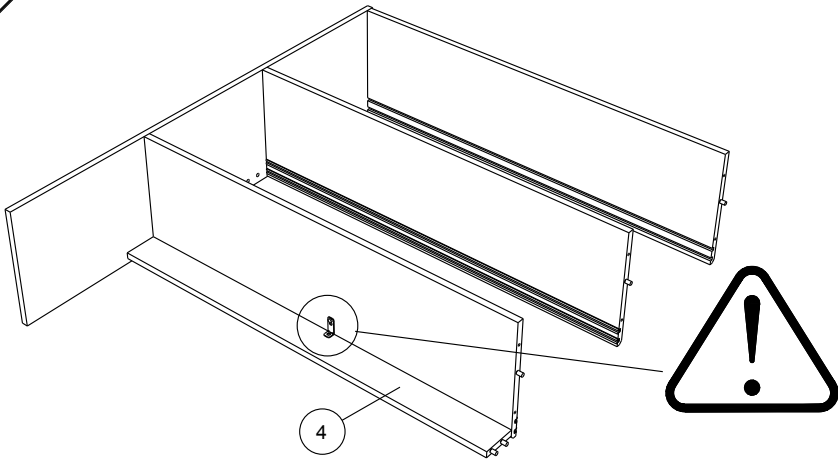

6

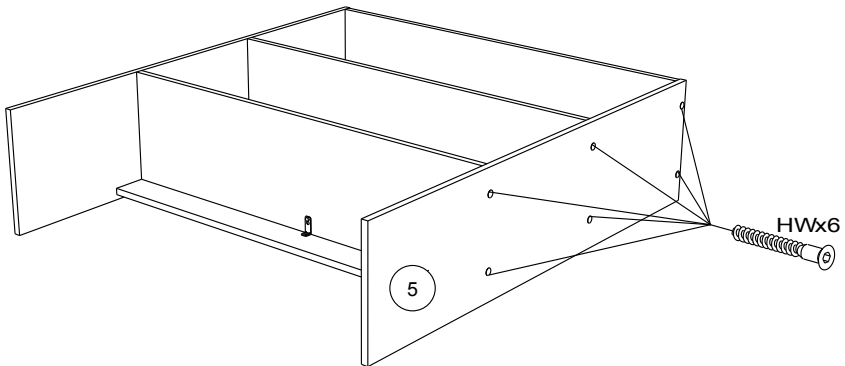

7

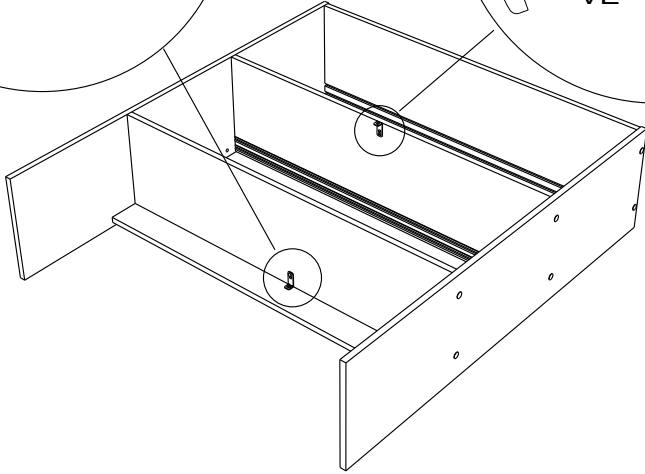
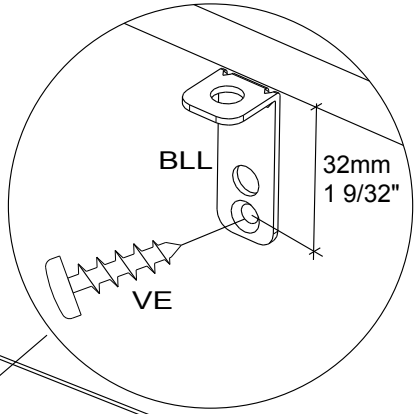
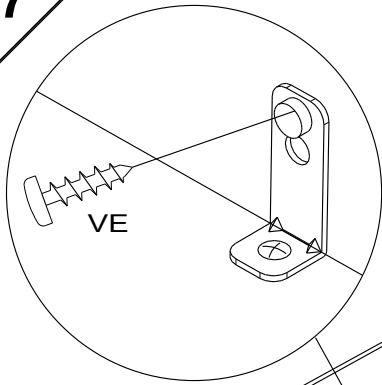

8

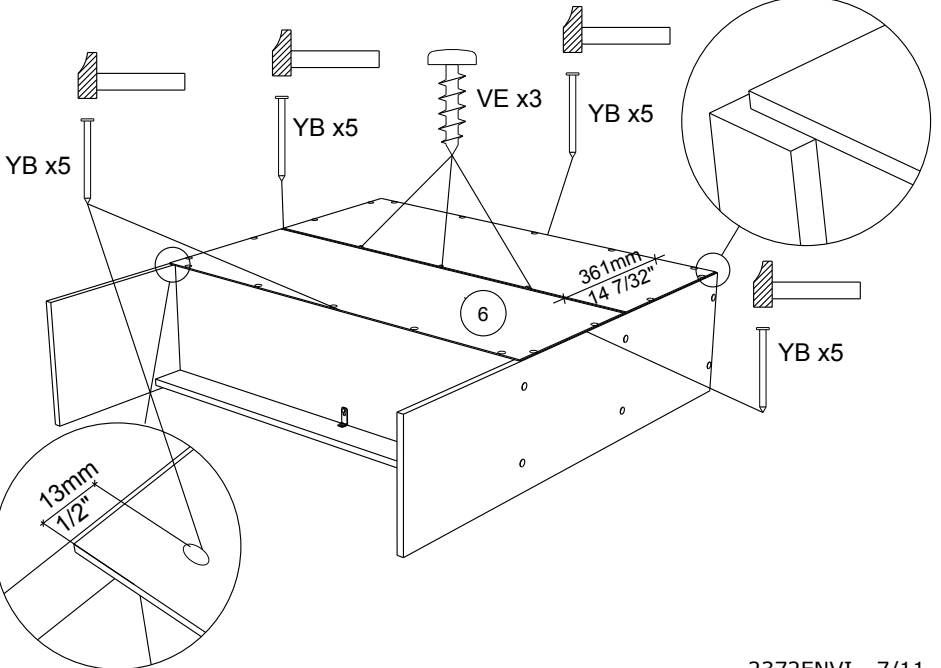

9

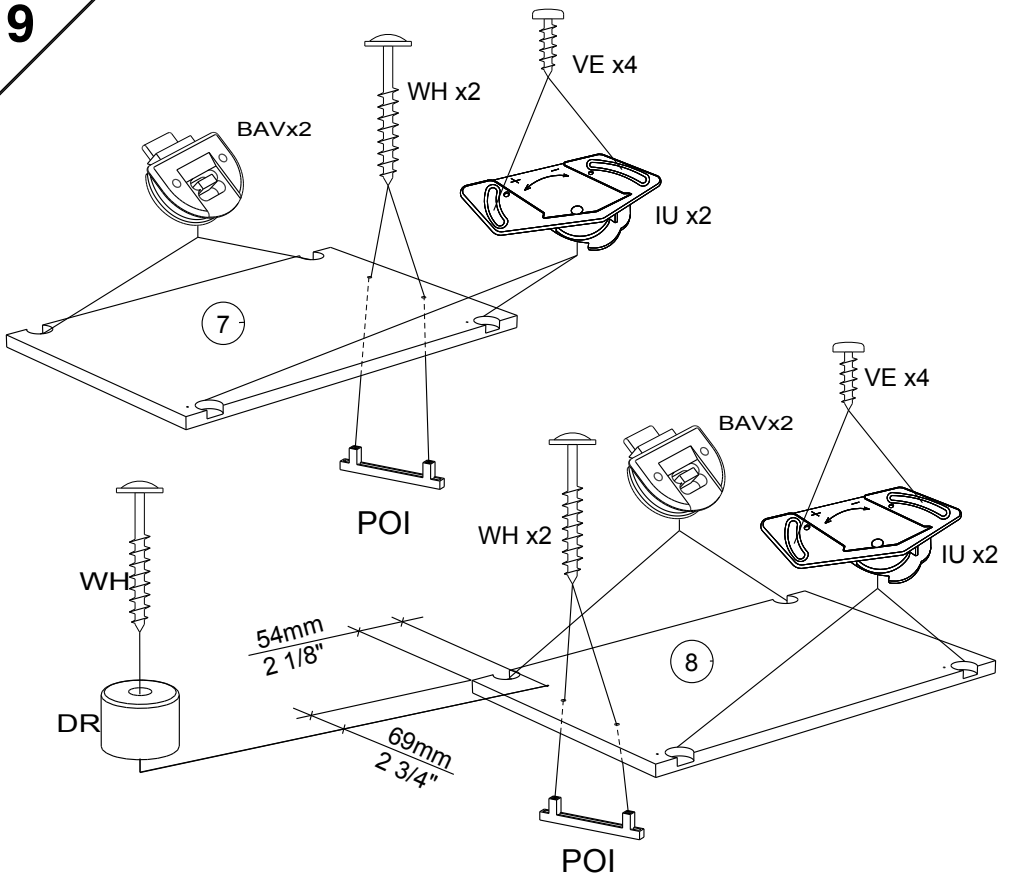

10

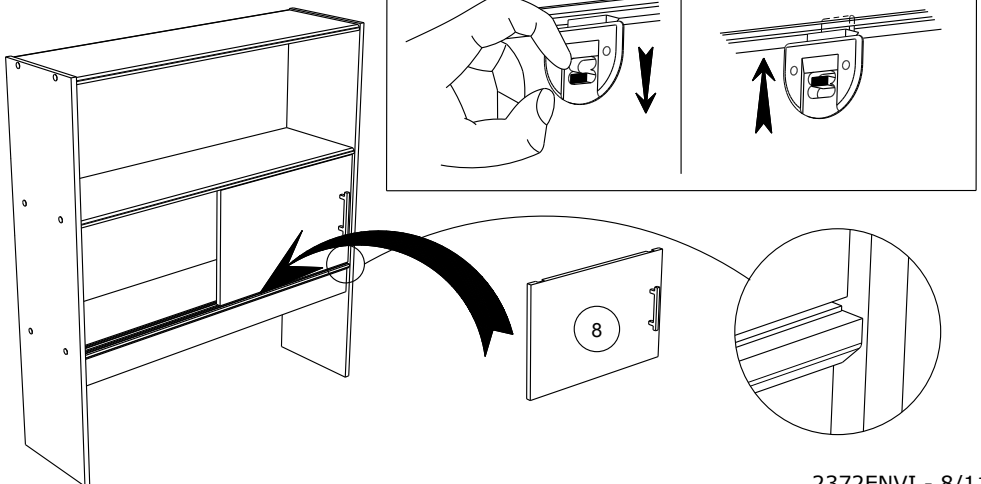

11

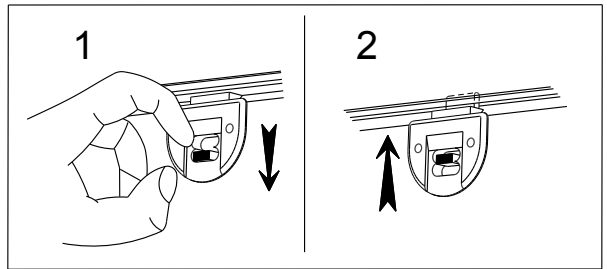
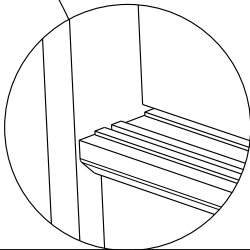
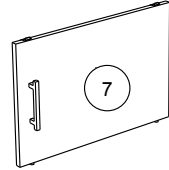
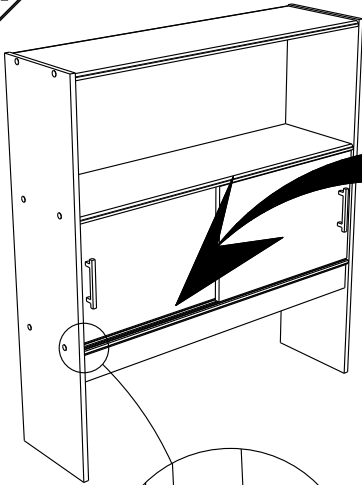

12

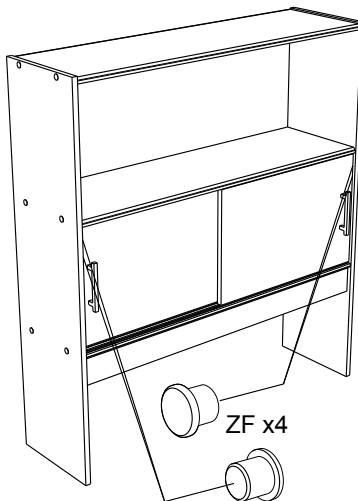

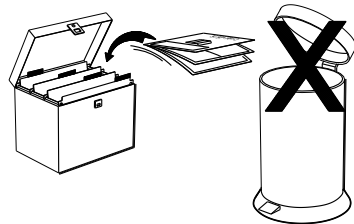
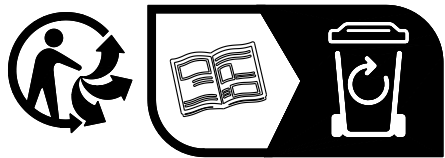
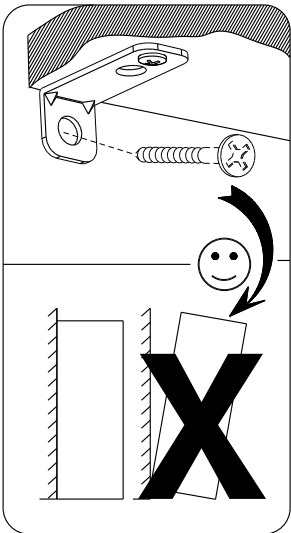
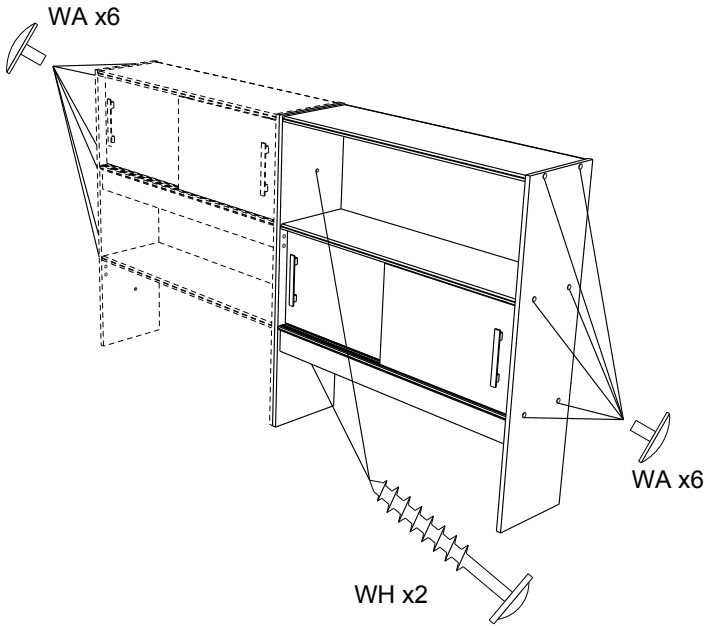

- FR** Pour votre sécurité : Fixation du meuble au mur
Attention, la fixation doit être réalisée par une personne compétente car cela nécessite des chevilles adaptées à la nature de votre mur.
- EN** For your safety: the unit should be secured to the wall.
NB this should be carried out by a competent person as you must use the right rawlplug for your type of wall.
- DE** Zu Ihrer Sicherheit: Befestigen Sie das Hochbett an der Wand.
Achtung: Diese Befestigung ist durch eine fachlich kompetente Person vorzunehmen. Hierfür sind für die Bauweise Ihrer Wand geeignete Dübel einzusetzen.
- ES** Por su seguridad: Fijar el mueble a la pared.
Advertencia: la fijación la ha de llevar a cabo por personal adecuado, ya que requiere el uso de tacos que se adapten al tipo de pared.
- PT** Para sua segurança: fixação do móvel ao muro
Atenção: a fixação deverá ser efetuada por pessoa habilitada, visto que são necessárias cavilhas adaptadas ao tipo de parede.
- IT** Avvertenza di sicurezza: il fissaggio del mobile a parete deve essere realizzato da una persona competente, in quanto l'operazione richiede l'impiego di tasselli adatti alla natura del muro.
- NL** Voor uw veiligheid: bevestiging van het meubel aan de muur.
Opgelet de bevestiging moet worden uitgevoerd door een bekwaam persoon daar dit voor uw type muur geschikte pluggen vereist.
- CZ** Z bezpečnostních důvodů: upevněte nábytek do zdi
Pozor, upevnění je třeba svěřit kompetentní osobě, neboť vyžaduje hmoždinky vhodné pro vaši zeď.
- HU** Az Ön biztonsága érdekében : a bútor falra rögzítése
Figyelmeztetés : a rögzítés csak megfelelő szakképesítéssel rendelkező személy által végezhető el, mert a rögzítéshez a falnak megfelelő csavarokra van szükség.
- PL** Dla bezpieczeństwa: mocowanie mebla do ściany
Uwaga, mocowanie musi zostać wykonane przez osobę kompetentną, ponieważ wymaga to zastosowania kołków dostosowanych do rodzaju ściany.
- RO** Pentru securitatea dumneavoastră: fixarea mobilierului de perete
Atenție, fixarea trebuie să fie realizată de o persoană calificată, deoarece sunt necesare dispozitive de fixare adaptate caracteristicilor peretelui dumneavoastră
- RU** Для вашей безопасности: Крепление мебели к стене
Внимание! Крепление должно производиться опытным специалистом, т.к. для такой установки потребуются штифты, соответствующие типу вашей стены.
- SK** Z bezpečnostných dôvodov: nábytok upevnite k stene.
Dbajte na to, aby upevnenie vykonala kompetentná osoba, pretože pri upevňovaní sa vyžadujú kolíky vhodné do materiálu, z ktorého je stena vyrobená.
- TR** Güvenliğiniz için: Mobilyanın duvara sabitlenmesi
Dikkat, sabitleme işlemleri uzman biri tarafından yapılmalıdır çünkü bu işlem için duvarınızın malzemesine uygun dübellerin kullanılması gerekmektedir
- GR** Για την ασφάλειά σας : στερέωση των επίπλων στον τοίχο.
Προσοχή, η στερέωση πρέπει να γίνεται από ικανό άτομο, καθώς απαιτούνται σφήνες προσαρμοσμένες στη φύση του τοίχου σας.

اللغة العربية

لسلامتك الشخصية: تثبيت قطعة الأثاث على الحائط
تحذير، يجب أن يقوم شخص متخصص بعملية التثبيت على الحائط إذ أنها تتطلب اسفيناً
معيناً يتوافق مع طبيعة الحائط نفسه.

2572ENVI

PARISOT INDUSTRIE 70800 SAINT LOUP SUR SEMOUSE -FRANCE-

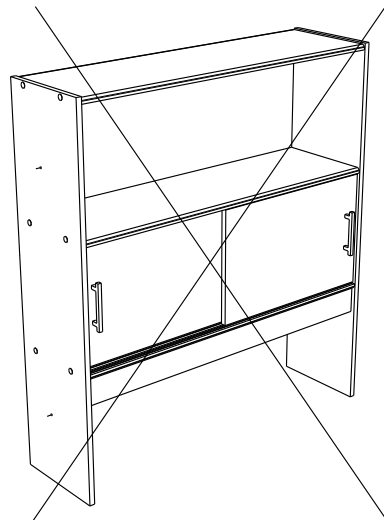
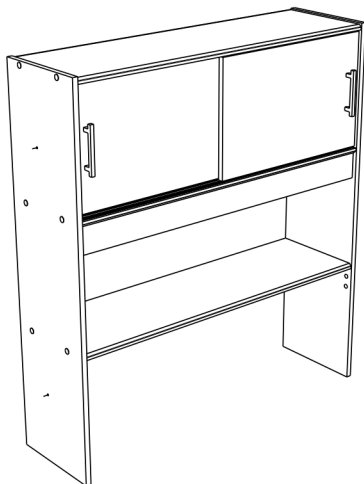

FR

Donnez ou recyclez
 vos meubles.



ou



ou



Association

Magasin

Déchèterie

<https://quefairedemesdechets.fr>

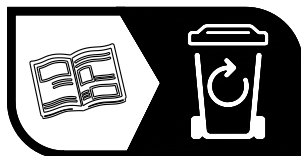

PARISOT INDUSTRIE

FR Remerciements :

Nous vous remercions d'avoir choisi un meuble créé et fabriqué par le Groupe Parisot et espérons qu'il vous donnera entière satisfaction.

EN Thanks:

Thank you for choosing furniture designed and manufactured by the Parisot Group. We hope you are totally satisfied with your purchase.

DE Danksagung:

Wir danken Ihnen für den Kauf eines Frankreich von der Parisot-Gruppe entworfenen und hergestellten Möbelstücks und hoffen, dass Sie es zu Ihrer vollkommenen Zufriedenheit finden werden.

ES Agradecimientos:

Les damos las gracias por haber elegido un mueble diseñado y fabricado por el Groupe Parisot y esperamos que sea de su total agrado.

PT Agradecimentos:

Obrigado por ter escolhido um móvel concebido e fabricado pelo Grupo Parisot, esperando que seja do seu inteiro agrado.

IT Ringraziamenti:

Grazie per avere scelto un mobile progettato e fabbricato dal Gruppo Parisot. Speriamo soddisfisi appieno le vostre esigenze.

NL Bedankje:

Wij bedanken u voor de aankoop van een door de Groep Parisot ontworpen en vervaardigd meubel en hopen dat u er veel plezier aan zult beleven.

CZ Poděkování:

Děkujeme, že jste si vybrali nábytek navržený a vyrobený společností Parisot Group. Doufáme, že budete svým nákupem naprosto spokojeni.

HU Köszönet:

Köszönjük, hogy a Parisot Groupe által létrehozott és gyártott bútort választott, reméljük, hogy elégedett lesz a termékkel.

PL Podziękowania:

Dziękujemy za wybór mebli stworzonych i wyprodukowanych przez Grupę Parisot. Mamy nadzieję, że będziecie Państwo w pełni zadowoleni z zakupu.

RO Mulțumiri:

Vă mulțumim că ați ales un articol de mobilier conceput și fabricat de Grupul Parisot și sperăm că veți fi pe deplin satisfăcuți de acesta.

RU Благодарность:

Мы благодарим вас за то, что вы выбрали мебель, созданную и произведенную Групп Париизо, и надеемся, что вы будете полностью удовлетворены нашей продукцией.

SK Pod'akovanie:

Ďakujeme, že ste si vybrali nábytok navrhnutý a vyrobený spoločnosťou Parisot Group. Dúfame, že budete svojim nákupom absolútne spokojní.

TR Teşekkür ederiz:

Parisot Group tarafından tasarlanan ve üretilen bu mobilyayı seçtiğiniz için teşekkür ederiz. Ürünümüzden memnun kalmanızı ümit ederiz.

AR : شكر

نشكركم لاختياركم هذه القطعة من الأثاث من تصميم وتصنيع مجموعة باريسو Parisot وتتمنى أن تتلوا رضائكم.

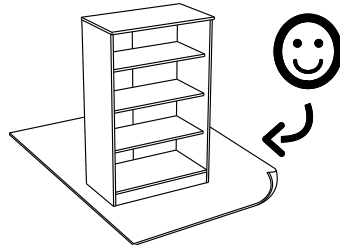
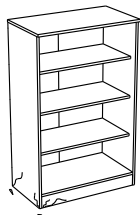
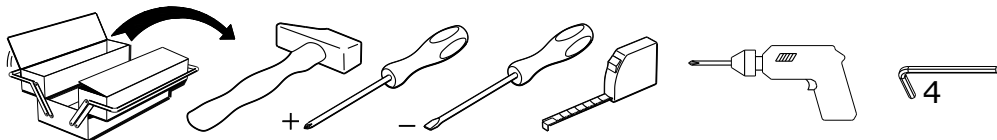

contact@parisot.com



www.parisot.com

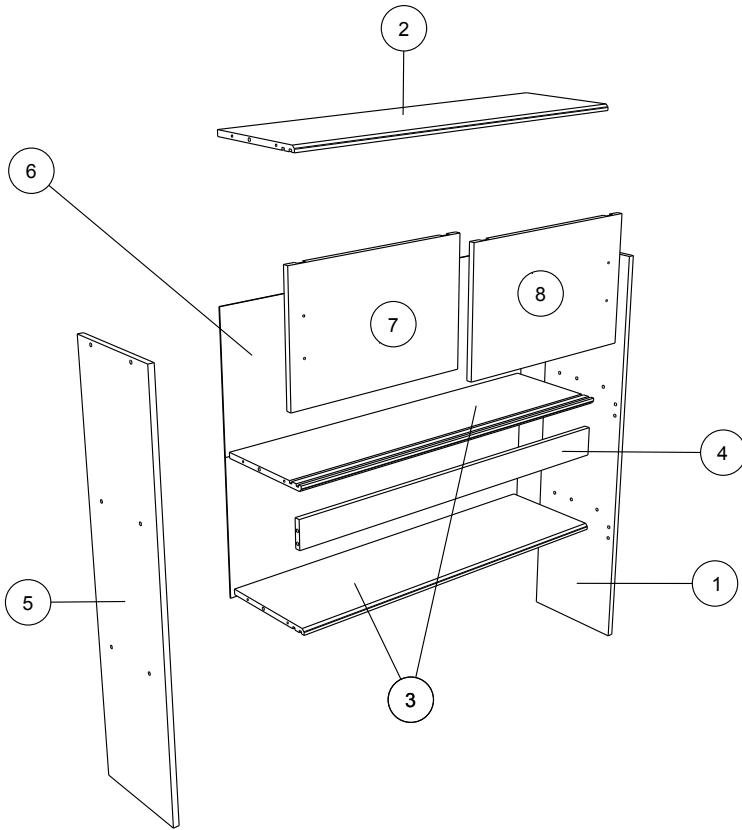

		mm			inch		
7	x 1	496	330	15	19 1/2	13	9/16
8	x 1	496	330	15	19 1/2	13	9/16
4	x 1	948	76	15	37 5/16	3	9/16
2	x 1	948	278	15	37 5/16	10 15/16	9/16
3	x 2	948	278	15	37 5/16	10 15/16	9/16
1	x 1	1080	280	15	42 1/2	11	9/16
5	x 1	1080	280	15	42 1/2	11	9/16
6	x 1	972	729	3	38 1/4	28 11/16	1/8

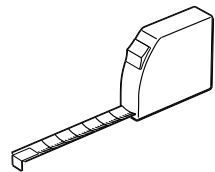

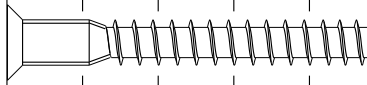
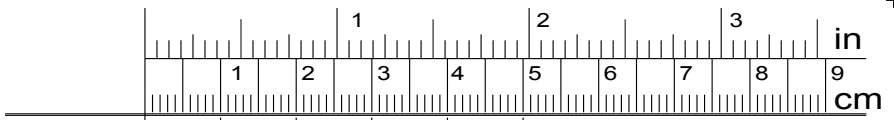

HW x 12

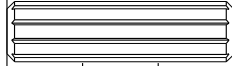

ADM x 10

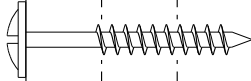

WH x 7

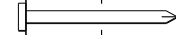

YB x 20

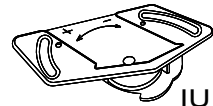

IU x 4

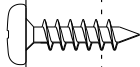

VE x 13

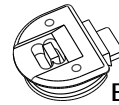

BAV x 4

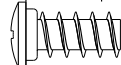

VB x 1

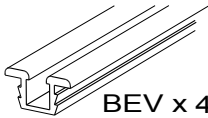

BEV x 4

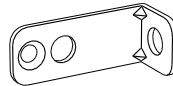

BLL x 2

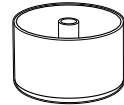

DR x 1



ZF x 4



WA x 12

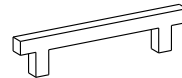

POI x 2

1

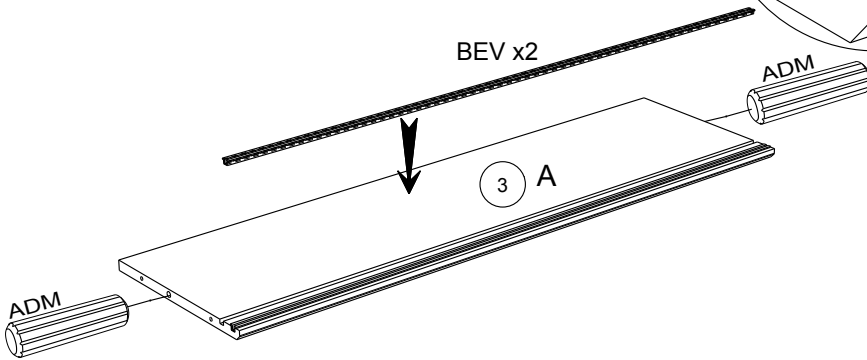
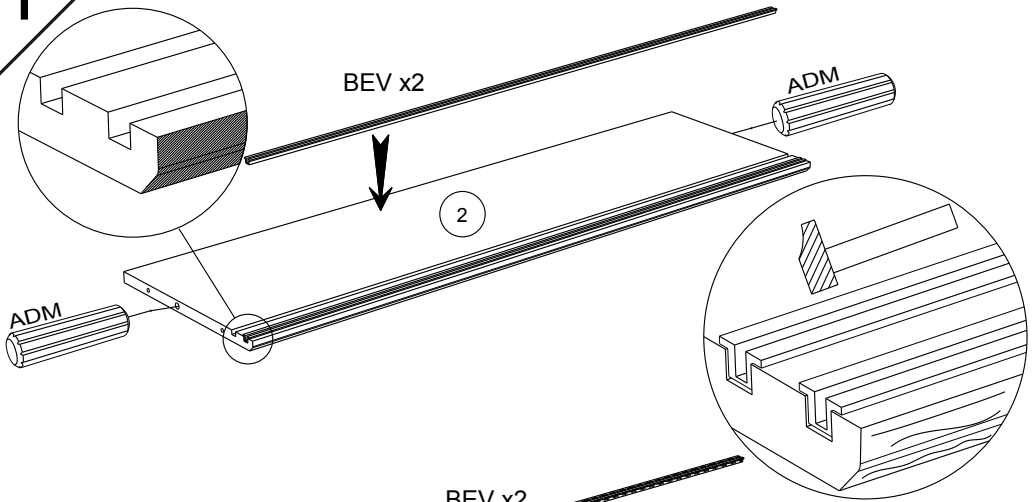

2

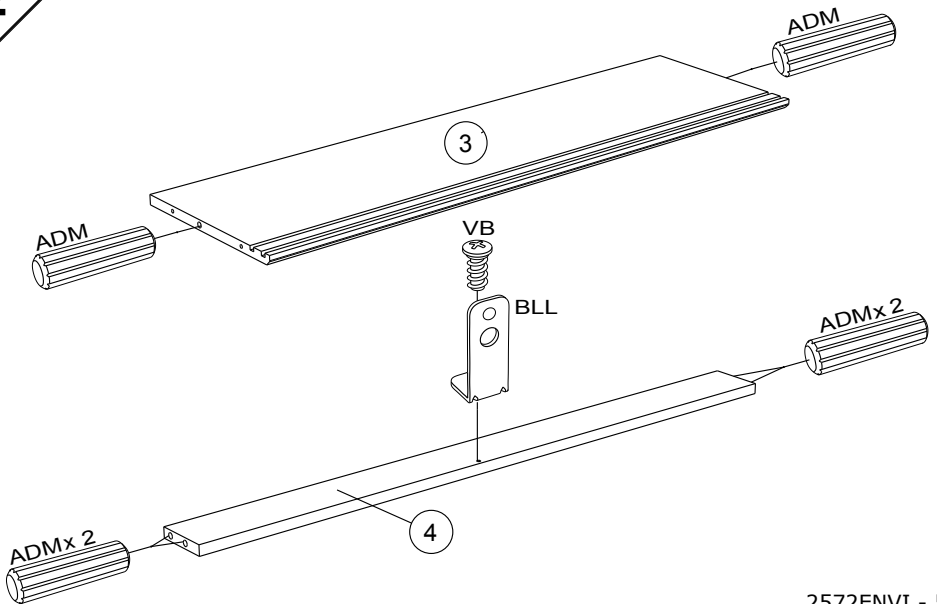

3

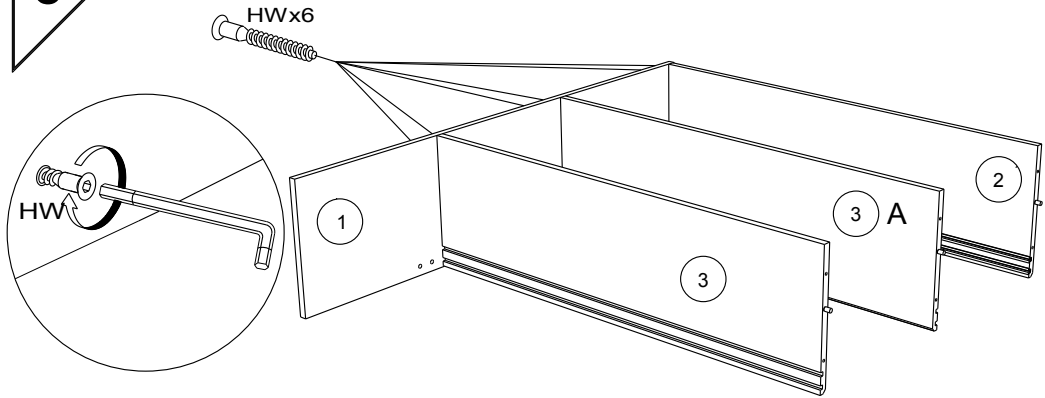

4

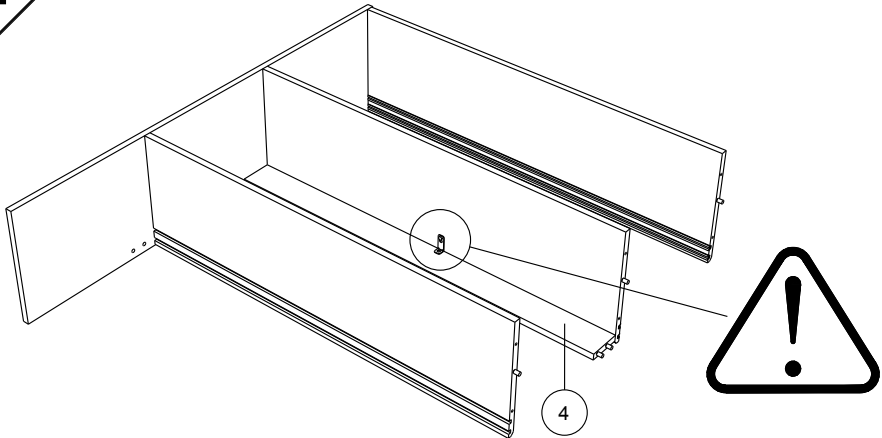

5

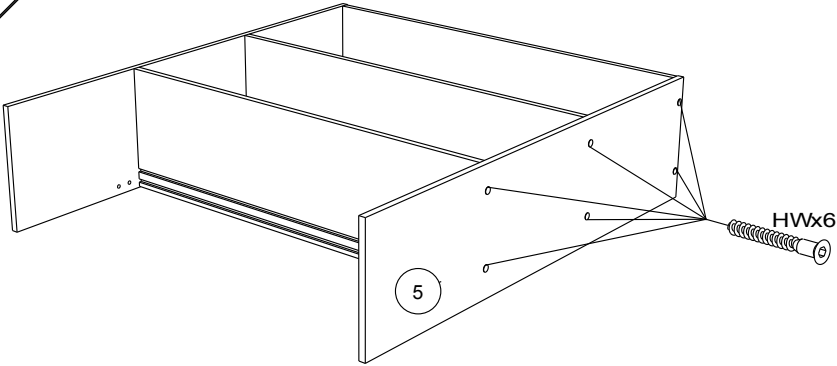

6

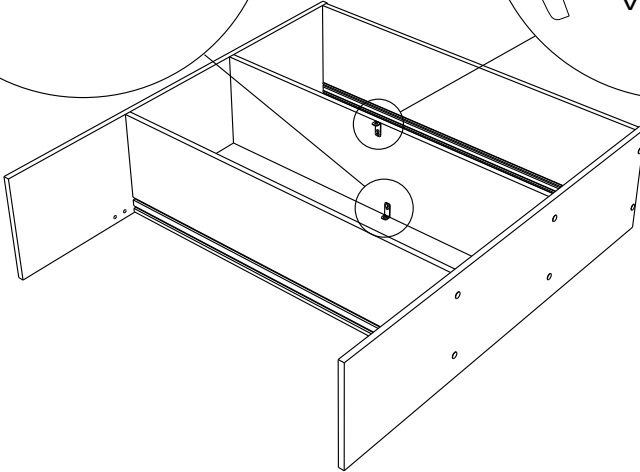
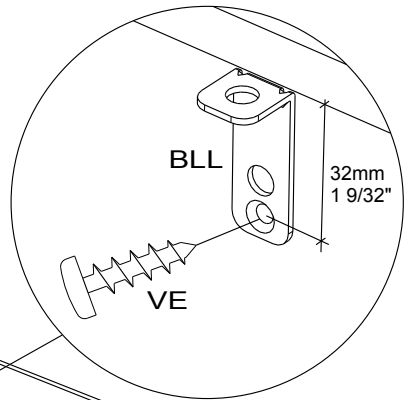
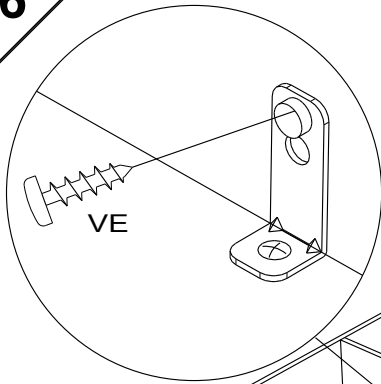

7

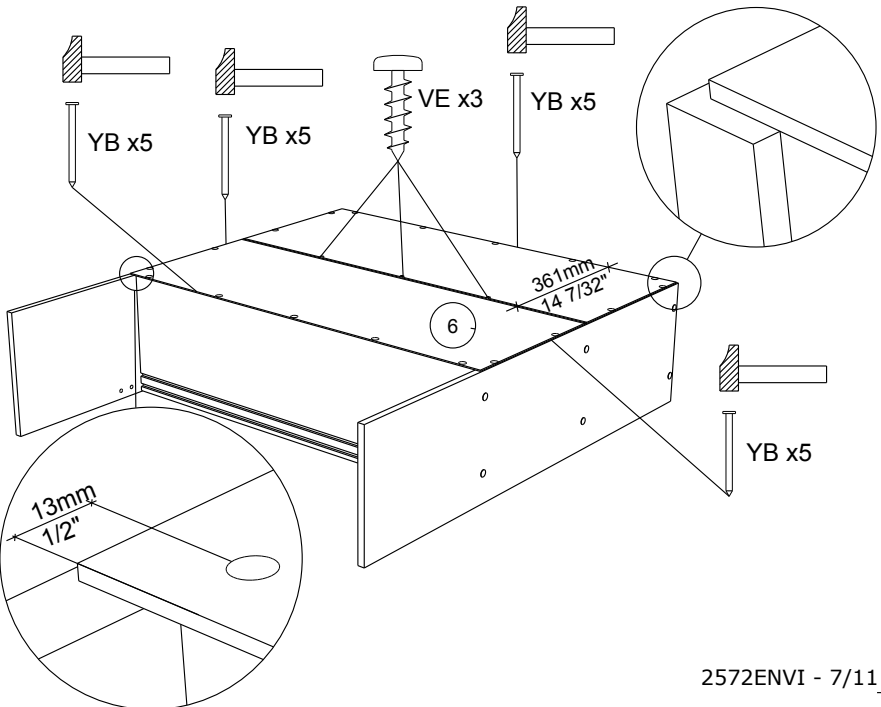

8

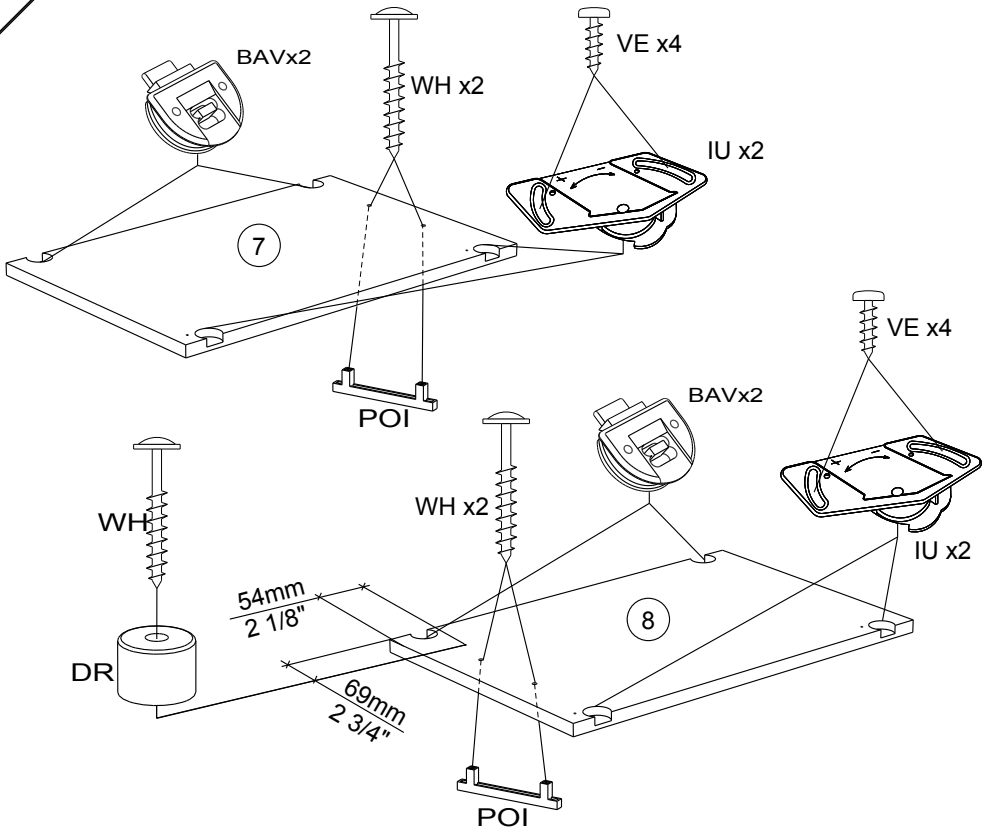

9

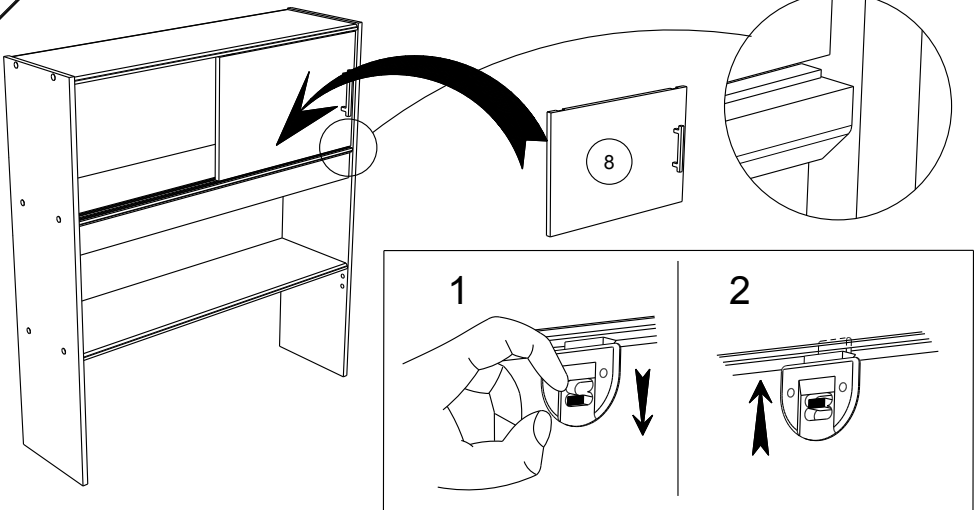

10

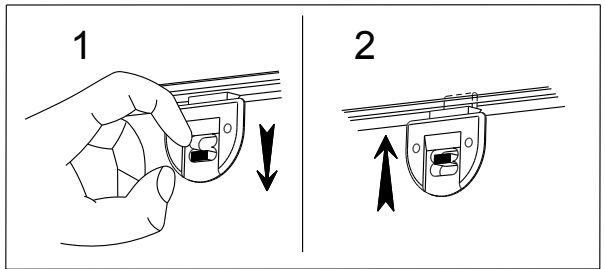
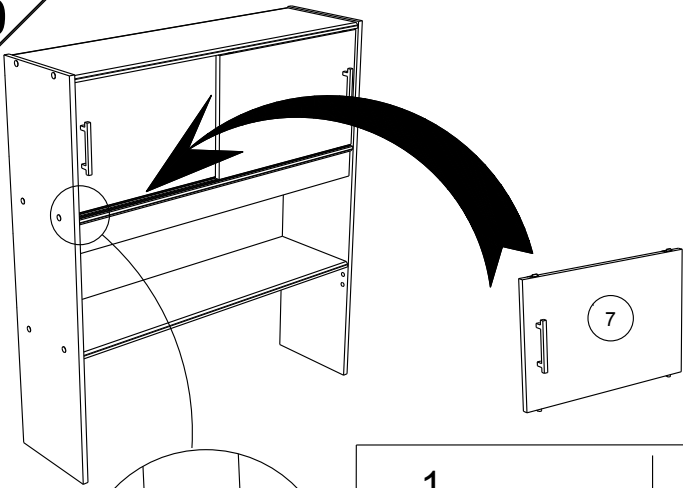

11

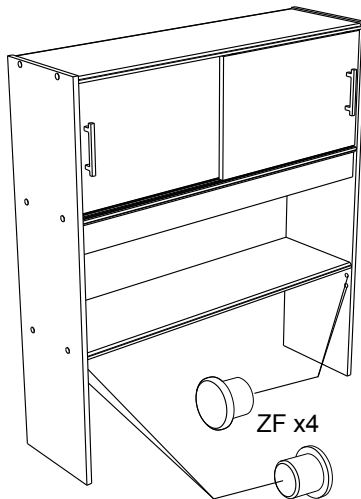

12

WA x6

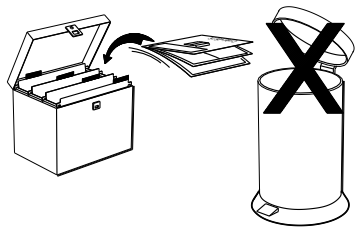
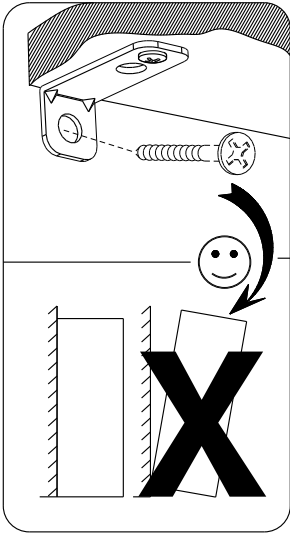
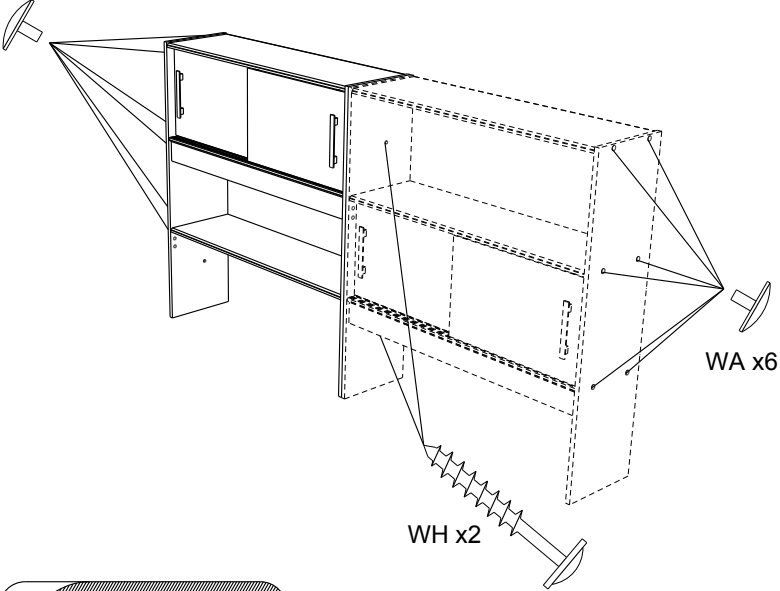

- FR** Pour votre sécurité : Fixation du meuble au mur
Attention, la fixation doit être réalisée par une personne compétente car cela nécessite des chevilles adaptées à la nature de votre mur.
- EN** For your safety: the unit should be secured to the wall.
NB this should be carried out by a competent person as you must use the right rawlplug for your type of wall.
- DE** Zu Ihrer Sicherheit: Befestigen Sie das Hochbett an der Wand.
Achtung: Diese Befestigung ist durch eine fachlich kompetente Person vorzunehmen.
Hierfür sind für die Bauweise Ihrer Wand geeignete Dübel einzusetzen.
- ES** Por su seguridad: Fijar el mueble a la pared.
Advertencia: la fijación la ha de llevar a cabo por personal adecuado, ya que requiere el uso de tacos que se adapten al tipo de pared.
- PT** Para sua segurança: fixação do móvel ao muro
Atenção: a fixação deverá ser efetuada por pessoa habilitada, visto que são necessárias cavilhas adaptadas ao tipo de parede.
- IT** Avvertenza di sicurezza: il fissaggio del mobile a parete deve essere realizzato da una persona competente, in quanto l'operazione richiede l'impiego di tasselli adatti alla natura del muro.
- NL** Voor uw veiligheid: bevestiging van het meubel aan de muur.
Opgelet de bevestiging moet worden uitgevoerd door een bekwame persoon daar dit voor uw type muur geschikte pluggen vereist.
- CZ** Z bezpečnostních důvodů: upevněte nábytek do zdi
Pozor, upevnění je třeba svěřit kompetentní osobě, neboť vyžaduje hmoždinky vhodné pro vaši zeď.
- HU** Az Ön biztonságá érdekében : a bútor falra rögzítése
Figyelmeztetés : a rögzítés csak megfelelő szakképesítéssel rendelkező személy által végezhető el, mert a rögzítéshez a falnak megfelelő csavarokra van szükség.
- PL** Dla bezpieczeństwa: mocowanie mebla do ściany
Uwaga, mocowanie musi zostać wykonane przez osobę kompetentną, ponieważ wymaga to zastosowania kołków dostosowanych do rodzaju ściany.
- RO** Pentru securitatea dumneavoastră: fixarea mobilierului de perete
Atenție, fixarea trebuie să fie realizată de o persoană calificată, deoarece sunt necesare dispozitive de fixare adaptate caracteristicilor peretelui dumneavoastră
- RU** Для вашей безопасности: Крепление мебели к стене
Внимание! Крепление должно производиться опытным специалистом, т.к. для такой установки потребуются штифты, соответствующие типу вашей стены.
- SK** Z bezpečnostných dôvodov: nábytok upevnite k stene.
Dbajte na to, aby upevnenie vykonala kompetentná osoba, pretože pri upevňovaní sa vyžadujú kolíky vhodné do materiálu, z ktorého je stena vyrobená.
- TR** Güvenliğiniz için: Mobilyanın duvara sabitlenmesi
Dikkat, sabitleme işlemi uzman biri tarafından yapılmalıdır çünkü bu işlem için duvarınızın malzemesine uygun dübellerin kullanılması gerekmektedir
- GR** Για την ασφάλειά σας : στερέωση των επίπλων στον τοίχο.
Προσοχή, η στερέωση πρέπει να γίνεται από ικανό άτομο, καθώς απαιτούνται σφίγγες προσαρμοσμένες στη φύση του τοίχου σας.

اللغة العربية

لسلامتك الشخصية: تثبيت قطعة الأثاث على الحائط
تحذير، يجب أن يقوم شخص متخصص بعملية التثبيت على الحائط إذ أنها تتطلب اسفينا
معينا يتوافق مع طبيعة الحائط نفسه.

20219C

6493BUR1-ECR

PARISOT INDUSTRIE 70800 SAINT LOUP SUR SEMOUSE -FRANCE-



FR Remerciements :

Nous vous remercions d'avoir choisi un meuble créé et fabriqué par le Groupe Parisot et espérons qu'il vous donnera entière satisfaction.

EN Thanks:

Thank you for choosing furniture designed and manufactured by the Parisot Group. We hope you are totally satisfied with your purchase.

DE Danksagung:

Wir danken Ihnen für den Kauf eines Frankreich von der Parisot-Gruppe entworfenen und hergestellten Möbelstücks und hoffen, dass Sie es zu Ihrer vollkommenen Zufriedenheit finden werden.

HU Köszönet:

Köszönjük, hogy a Parisot Groupe által létrehozott és gyártott bútort választott, reméljük, hogy elégedett lesz a termékkel.

PT Agradecimentos:

Obrigado por ter escolhido um móvel concebido e fabricado pelo Grupo Parisot, esperando que seja do seu inteiro agrado.

IT Ringraziamenti:

Grazie per avere scelto un mobile progettato e fabbricato dal Gruppo Parisot. Speriamo soddisfatti appieno le vostre esigenze.

NL Bedankje:

Wij bedanken u voor de aankoop van een door de Groep Parisot ontworpen en vervaardigd meubel en hopen dat u er veel plezier aan zult beleven.

CZ Poděkování:

Děkujeme, že jste si vybrali nábytek navržený a vyrobený společností Parisot Group. Doufáme, že budete svým nákupem naprosto spokojeni.

ES Agradecimientos:

Les damos las gracias por haber elegido un mueble diseñado y fabricado por el Grupo Parisot y esperamos que sea de su total agrado.

PL Podziękowania:

Dziękujemy za wybór mebli stworzonych i wyprodukowanych przez Grupę Parisot. Mamy nadzieję, że będziecie Państwo w pełni zadowoleni z zakupu.

SK Pod'akovanie:

Ďakujeme, že ste si vybrali nábytok navrhnutý a vyrobený spoločnosťou Parisot Group. Dúfame, že budete svojim nákupom absolútne spokojní.

AR شكر:

نشكركم لاختياركم هذه القطعة من الأثاث من تصميم وتصنيع مجموعة باريسو Parisot ونتمنى أن تتال رضاءكم.

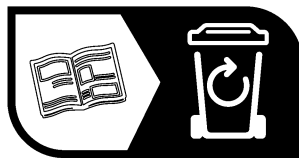
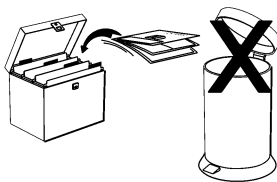

FR

Donnez ou recyclez vos meubles.



ou



ou



Association

Magasin

Déchèterie

<https://quefairedemesdechets.fr>

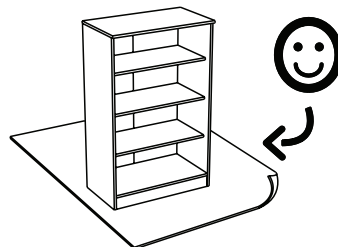
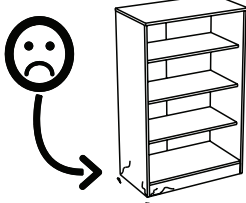
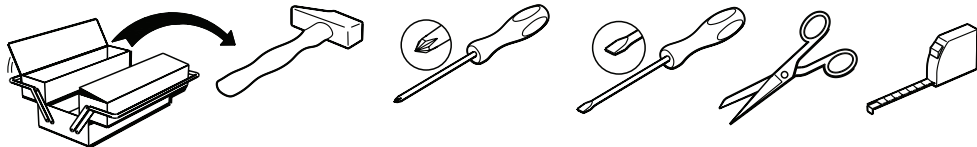

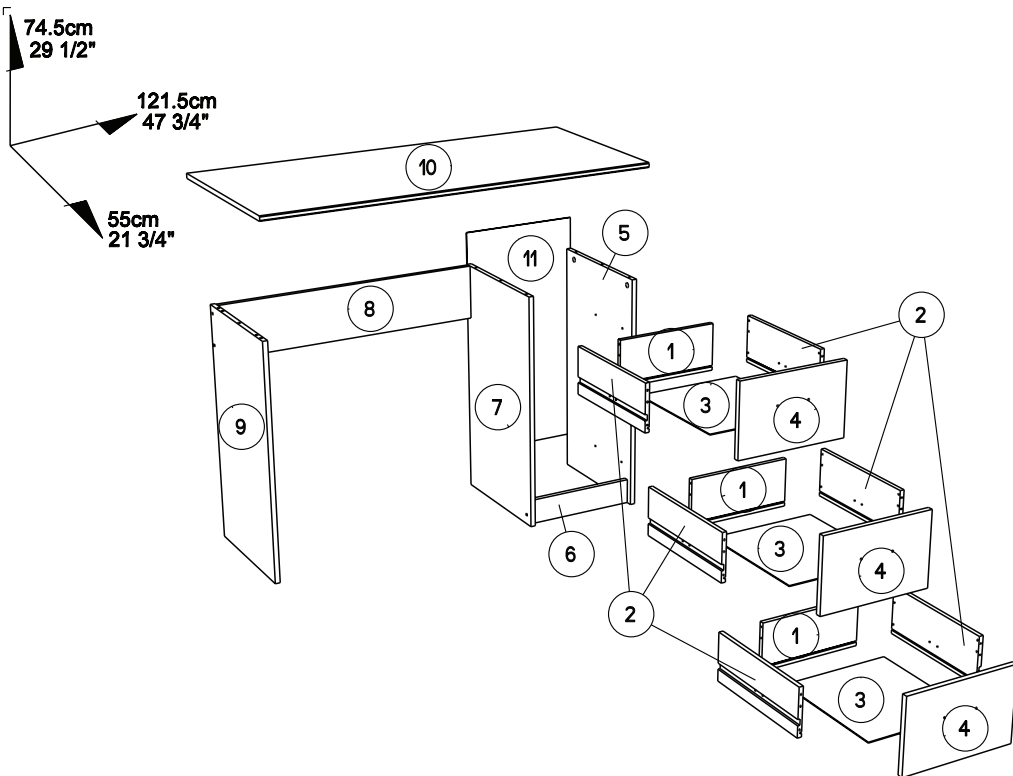

		mm			inch		
④	x 3	332	214	15	13 1/16	8 7/16	9/16
⑥	x 1	336	76	15	13 1/4	3	9/16
⑤	x 1	724	395	15	28 1/2	15 9/16	9/16
⑨	x 1	724	395	15	28 1/2	15 9/16	9/16
⑦	x 1	724	395	15	28 1/2	15 9/16	9/16
⑧	x 1	813	166	15	32	6 1/2	9/16
⑩	x 1	1212	550	15	47 11/16	21 5/8	9/16
②	x 6	350	138	13	13 3/4	5 7/16	1/2
①	x 3	303	138	13	11 15/16	5 7/16	1/2
③	x 3	349	314	3	13 3/4	12 3/8	1/8
⑪	x 1	719	363	3	28 5/16	14 5/16	1/8

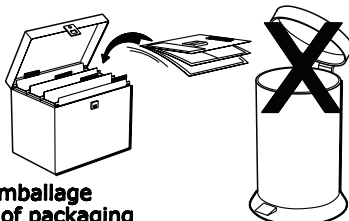
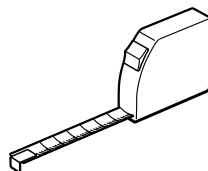

Faites un geste pour l'environnement en triant vos déchets d'emballage
 Make a gesture for the environment by sorting out your waste of packaging
 Machen Sie eine Bewegung für die Umwelt, ihre Verpackungsabfälle sortierend
 Haga un gesto para el medio ambiente escogiendo sus residuos de embalaje
 Pensate all'ambiente riciclando i vostri rifiuti di imballaggio
 Naredite uslugo okolju in ločujte odpadke

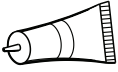

CF x2

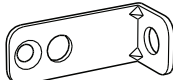

BLL x2



Ai x6



BQS x6



HV x1

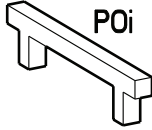

POi x3



WA x4

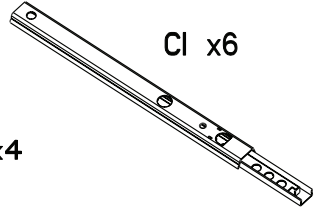

CI x6

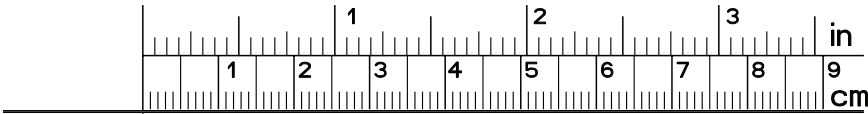

HW x6

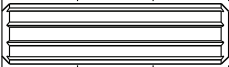

ADM x7



ADU x36

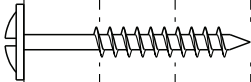

WH x6

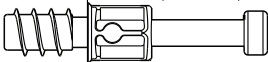

BSD x6

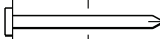

YB x10

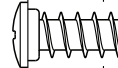
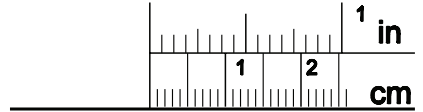

VB x1



VG x14



VR x6



ANK x12



x3

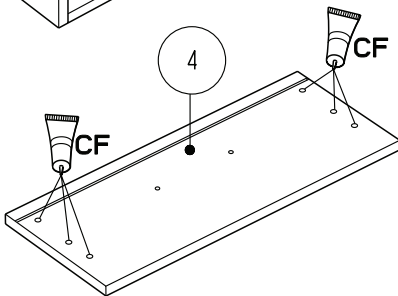
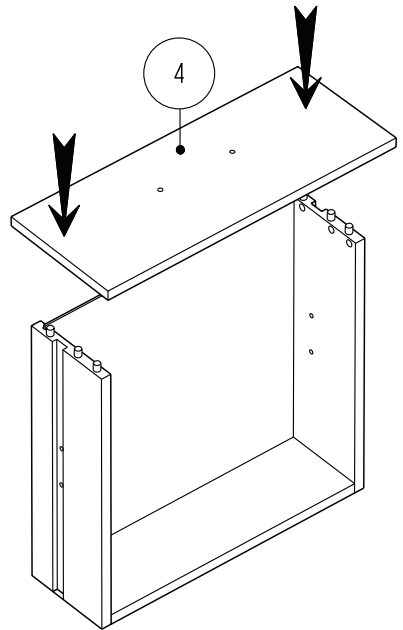
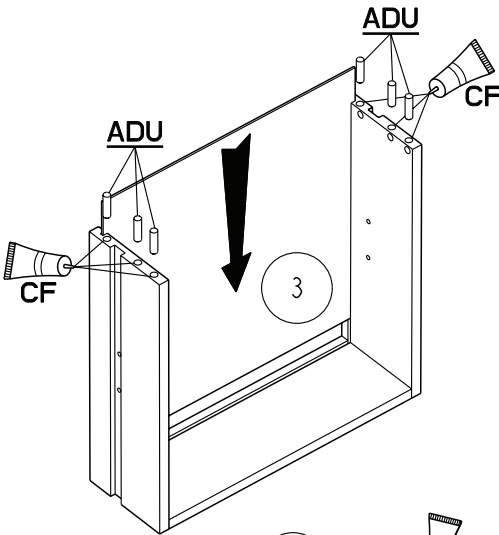
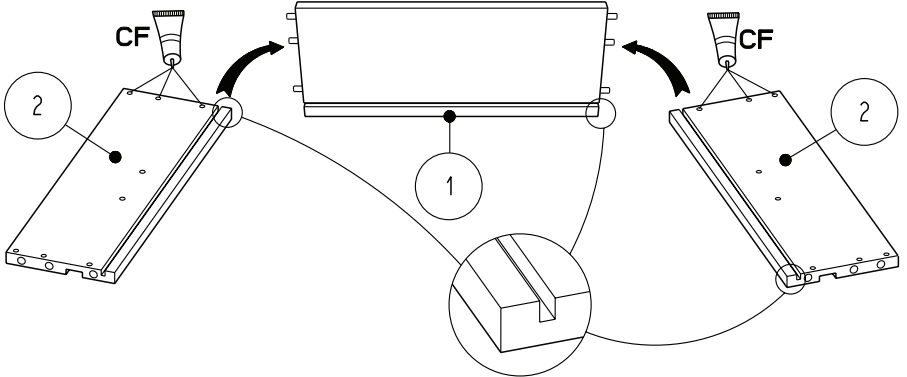
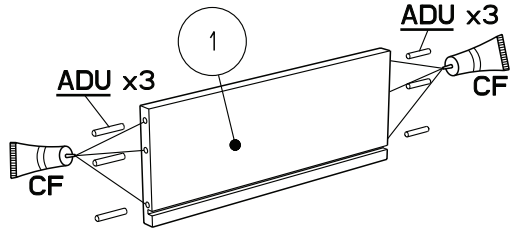

2

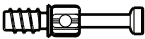

BSD x 6



VB x 1

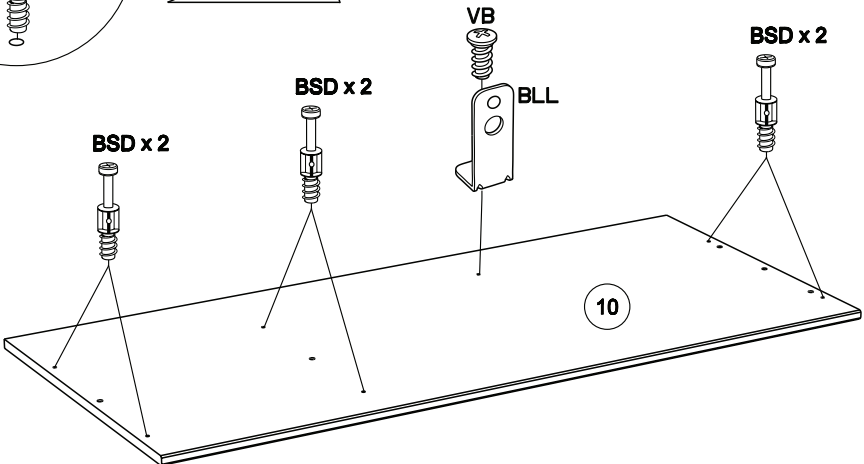
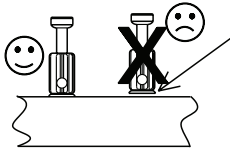
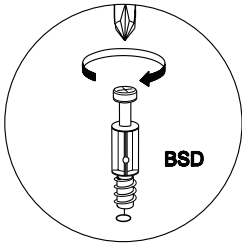
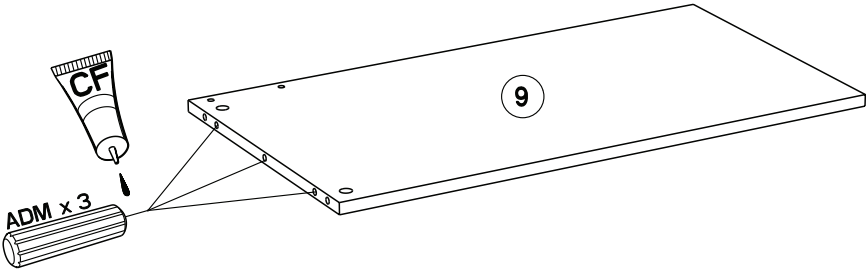
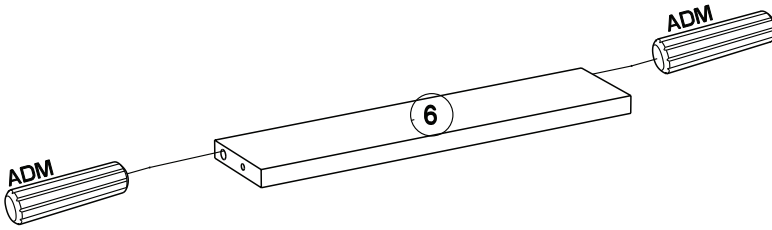

BLL x1

CF x 1

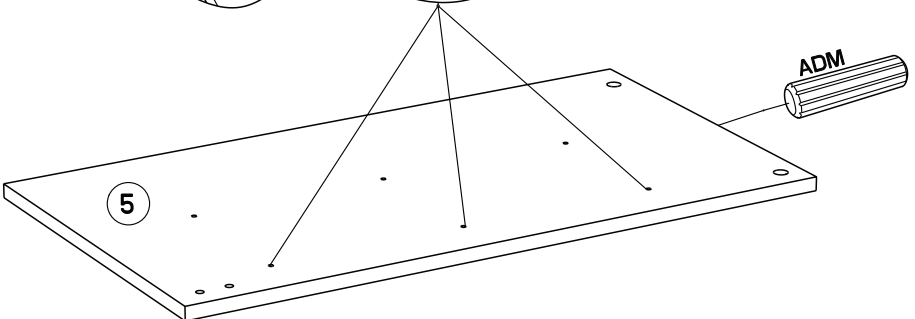
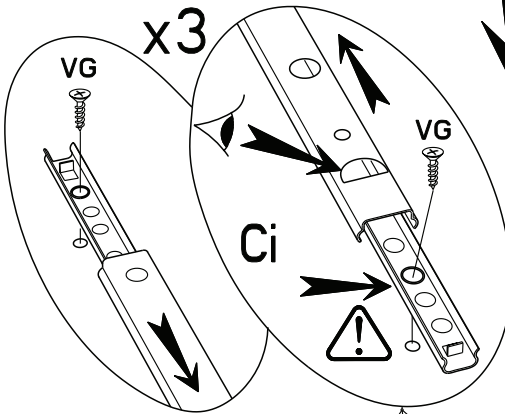
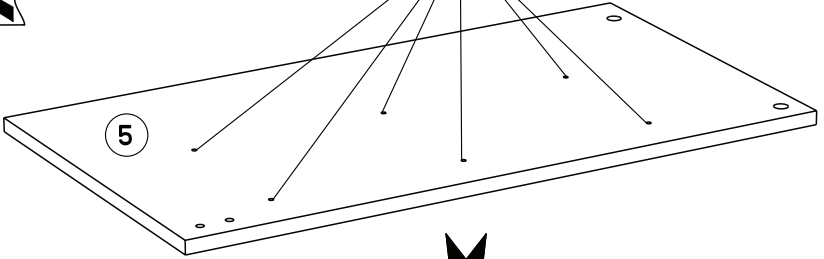
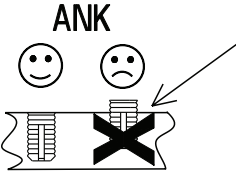
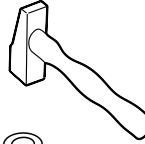
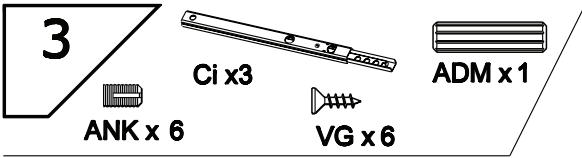
ADM x5



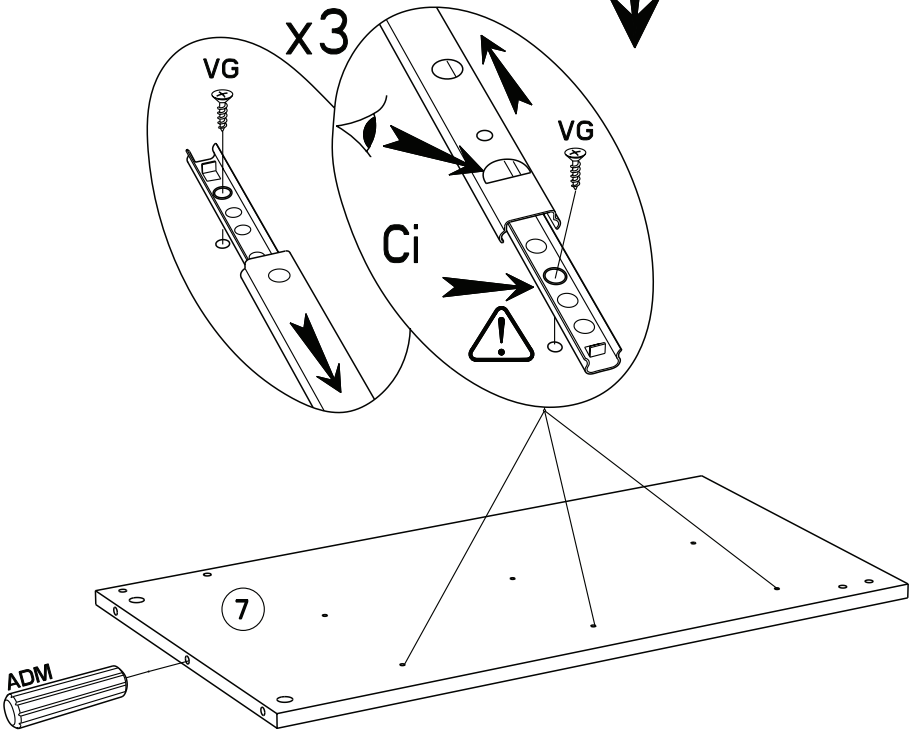
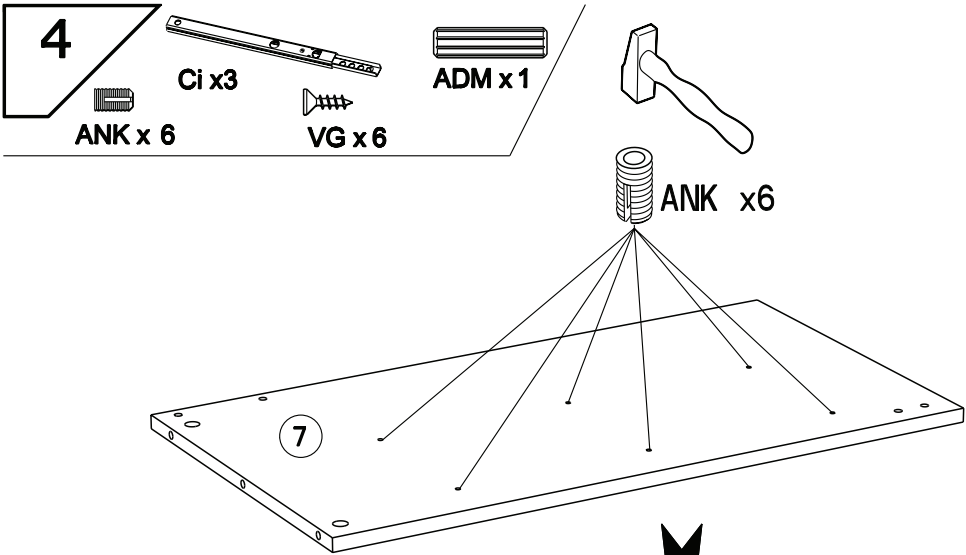



5



HV x1

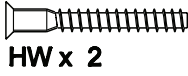

HW x 2



WA x 2



Ai x4

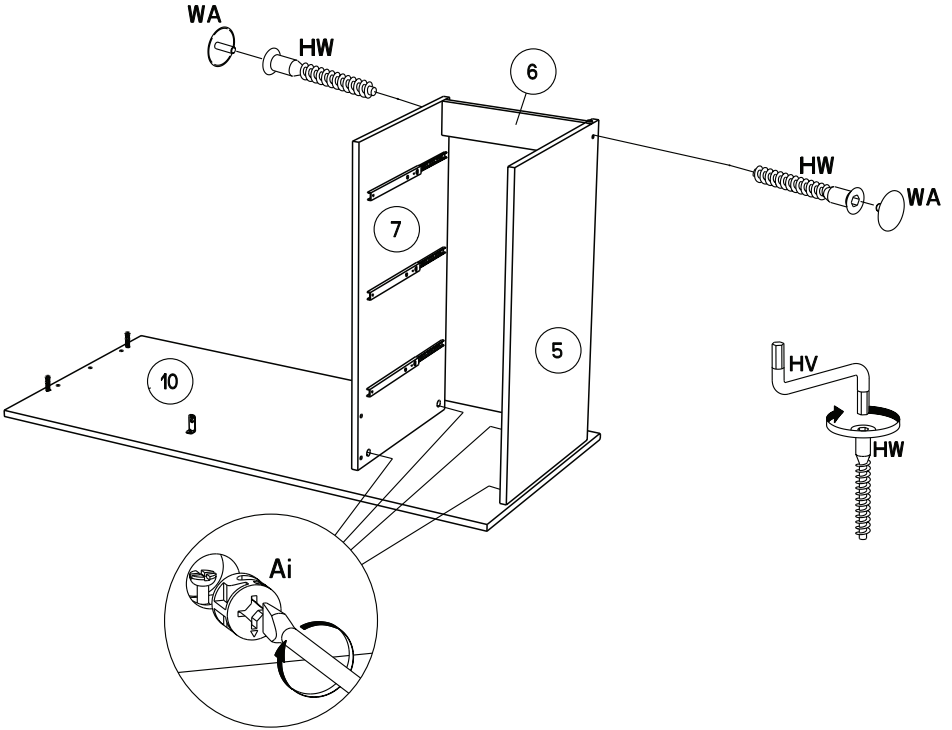

6

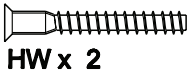

HW x 2

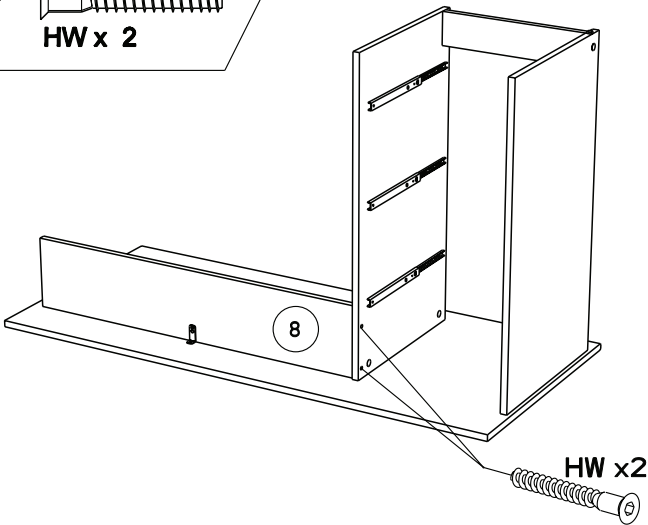

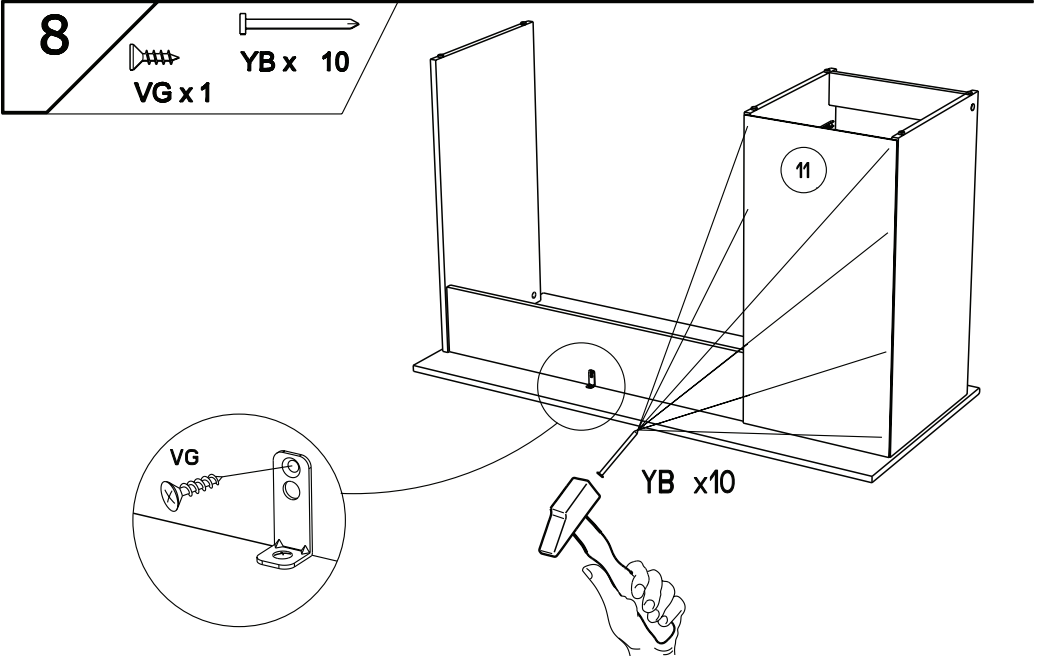
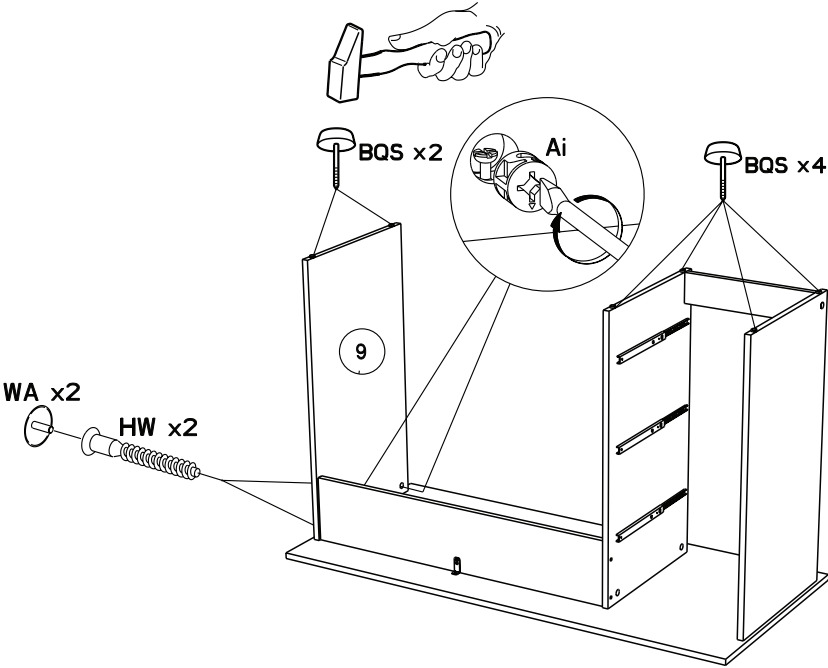
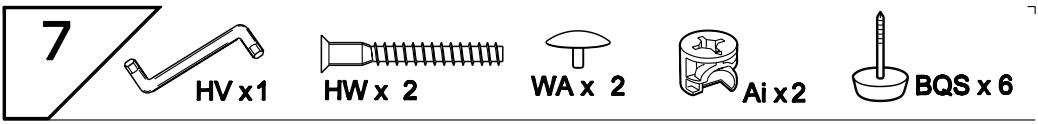

- FR** Pour votre sécurité : Fixation du meuble au mur.
Attention, la fixation doit être réalisée par une personne compétente car cela nécessite des chevilles adaptées à la nature de votre mur.
- EN** For your safety: the unit should be secured to the wall.
NB this should be carried out by a competent person as you must use the right rawlplug for your type of wall.
- DE** Zu Ihrer Sicherheit: Befestigen Sie das Möbel an der Wand.
Achtung: Diese Befestigung ist durch eine fachlich kompetente Person vorzunehmen.
Hierfür sind für die Bauweise Ihrer Wand geeignete Dübel einzusetzen.
- ES** Por su seguridad: Fijar el mueble a la pared.
Advertencia: la fijación la ha de llevar a cabo por personal adecuado, ya que requiere el uso de tacos que se adapten al tipo de pared.
- PT** Para sua segurança: fixação do móvel ao muro.
Atenção: a fixação deverá ser efetuada por pessoa habilitada, visto que são necessárias cavilhas adaptadas ao tipo de parede.
- IT** Avvertenza di sicurezza: il fissaggio del mobile a parete deve essere realizzato da una persona competente, in quanto l'operazione richiede l'impiego di tasselli adatti alla natura del muro.
- NL** Voor uw veiligheid: bevestiging van het meubel aan de muur.
Opgelet de bevestiging moet worden uitgevoerd door een bekwaam persoon daar dit voor uw type muur geschikte pluggen vereist.
- CZ** Z bezpečnostních důvodů: upevněte nábytek do zdi.
Pozor, upevnění je třeba svěřit kompetentní osobě, neboť vyžaduje hmoždinky vhodné pro vaši zeď.
- HU** Az Ön biztonsága érdekében : a bútor falra rögzítése.
Figyelmeztetés : a rögzítés csak megfelelő szakképesítéssel rendelkező személy által végezhető el, mert a rögzítéshez a falnak megfelelő csavarokra van szükség.
- PL** Dla bezpieczeństwa: mocowanie mebla do ściany.
Uwaga, mocowanie musi zostać wykonane przez osobę kompetentną, ponieważ wymaga to zastosowania kółków dostosowanych do rodzaju ściany.
- RO** Pentru securitatea dumneavoastră: fixarea mobilierului de perete.
Atenție, fixarea trebuie să fie realizată de o persoană calificată, deoarece sunt necesare dispozitive de fixare adaptate caracteristicilor peretelui dumneavoastră
- RU** Для вашей безопасности: Крепление мебели к стене
Внимание! Крепление должно производиться опытным специалистом, т.к. для такой установки потребуются штифты, соответствующие типу вашей стены.
- SK** Z bezpečnostných dôvodov: nábytok upevnite k stene.
Dbajte na to, aby upevnenie vykonala kompetentná osoba, pretože pri upevňovaní sa vyžadujú kolíky vhodné do materiálu, z ktorého je stena vyrobená.
- SL** Za vašo varnost: Enota naj bo pritrjena na steno. Pozor: To naj stori kompetentna oseba, ker je potrebno uporabiti pravilni nosilec glede na vrsto stene ki jo uporabljate.
- TR** Güvenliğiniz için: Mobilyanın duvara sabitlemesi
Dikkat, sabitleme işlemi uzman biri tarafından yapılmalıdır çünkü bu işlem için duvarınızın malzemesine uygun dübellerin kullanılmasını gerektirmektedir
- EL** Για την ασφάλειά σας : στερέωση των επίπλων στον τοίχο.
Προσοχή, η στερέωση πρέπει να γίνεται από ικανό άτομο, καθώς απαιτούνται σφήνες προσαρμοσμένες στη φύση του τοίχου σας.

AR لسلامتک الشخصیة: تثبیت قطعة الأثاث علی الحائط

تحذیر، یجب أن یقوم شخص متخصص بعملیة التثبیت علی الحائط إذ أنها تتطلب اسفینا معینا یتوافق مع طبیعة الحائط نفسه.

ZH 为了您的安全：本产品必须靠墙安装。

NB 本产品必须由专业人士安装，且您必须使用符合您的墙壁类型的罗威纤维管。

