

Art. Nr. 5148 2059, 1336 4440

LKZ 41164

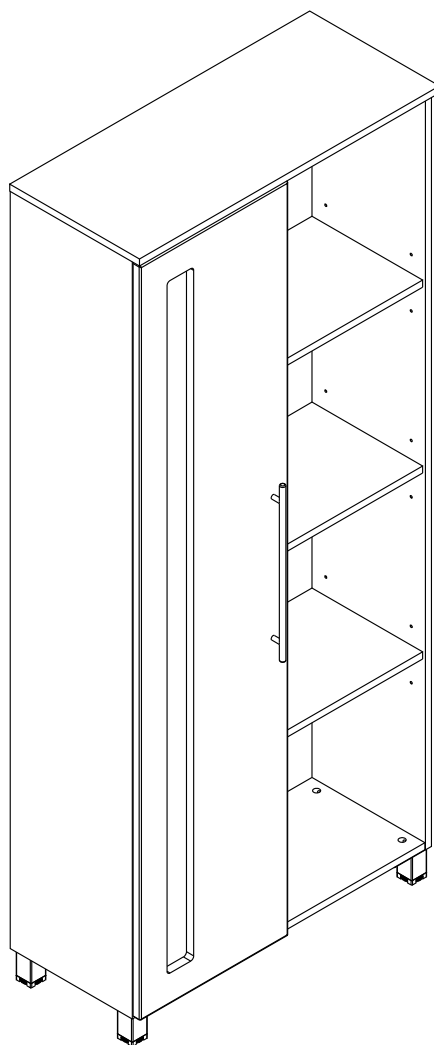

- | | |
|---------------------------------------|-----------------------------------|
| D Montageanleitung | GB Assembly instructions |
| FR Notice de montage | IT Istruzioni di montaggio |
| NL Handleiding voor de montage | PL Instrukcja montazu |
| CZ Montážní návod | SK Návod na montáž |
| HU Szerelési útmutató | RO Instrukțiuni de montaj |
| TR Montaj talimati | RU Инструкция по монтажу |

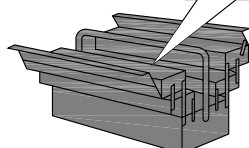
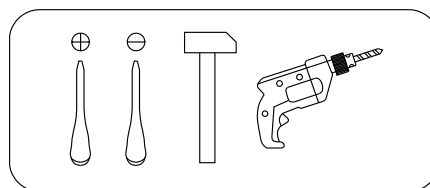
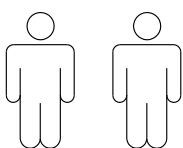

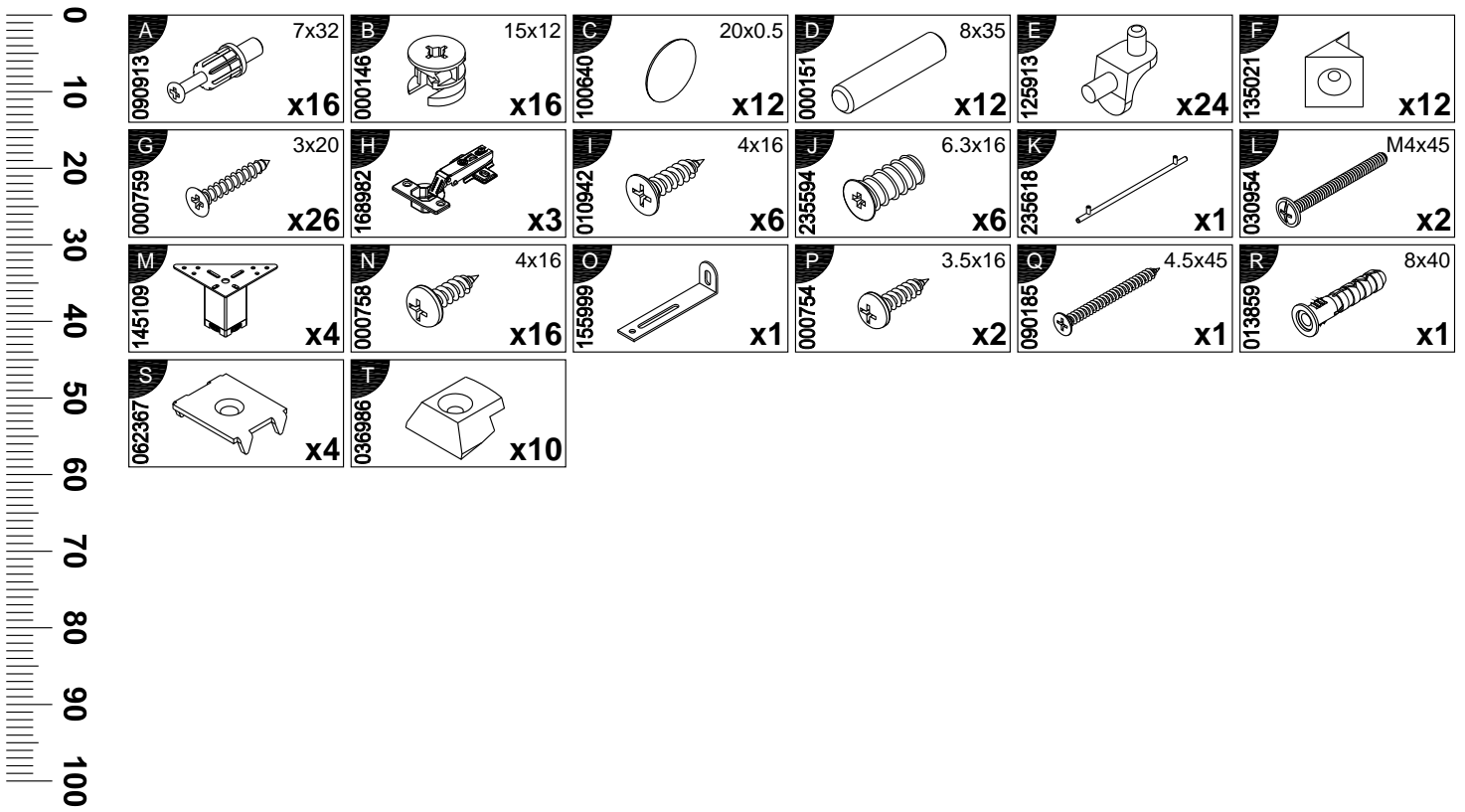

N	Size/MaB (mm)	Qty	✓	N	Size/MaB (mm)	Qty	✓
1	1720x320x16	1		6	752x319x16	1	
2	1720x320x16	1		7	368x290x16	6	
3	752x200x16	1		8	1712x388x19	1	
4	1704x296x16	1		9	1714x380x3	2	
5	786x340x16	1		10	1590x88x4	1	

Service - Dienstverlening - Serwis - Servis - Сервисная служба





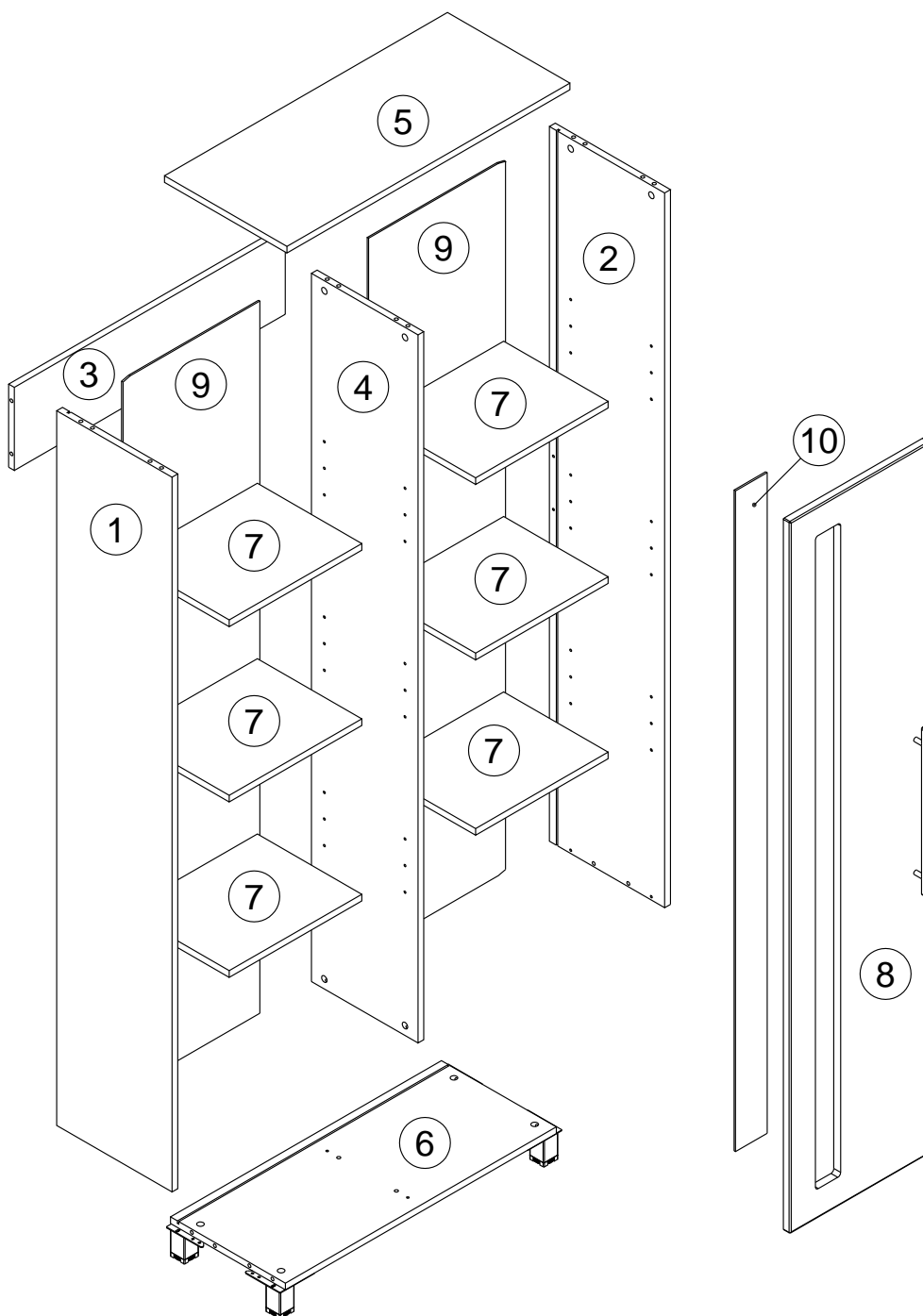
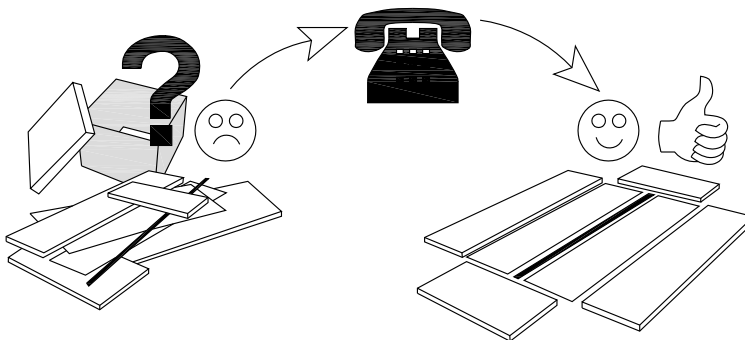
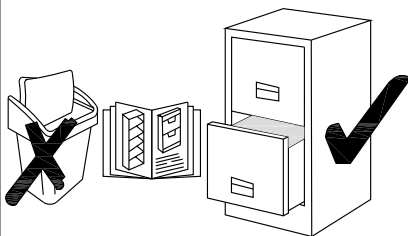

Name - Naam - Nazwa - Isim - Название

Nr. - No. - Номер

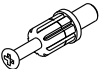
Typ - Type - Тип - Тип

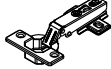

1

A 090913  7x32 x8	B 000146  15x12 x4	D 000151  8x35 x4	E 125913  x12	H 168982  x3	J 235594  6.3x16 x6
--	---	--	--	--	--

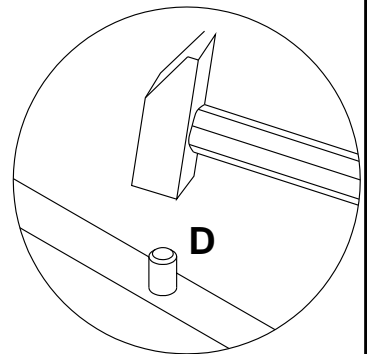
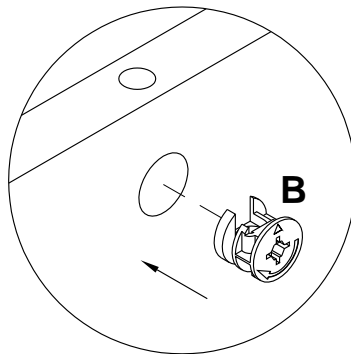
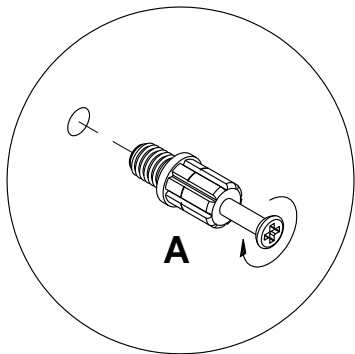
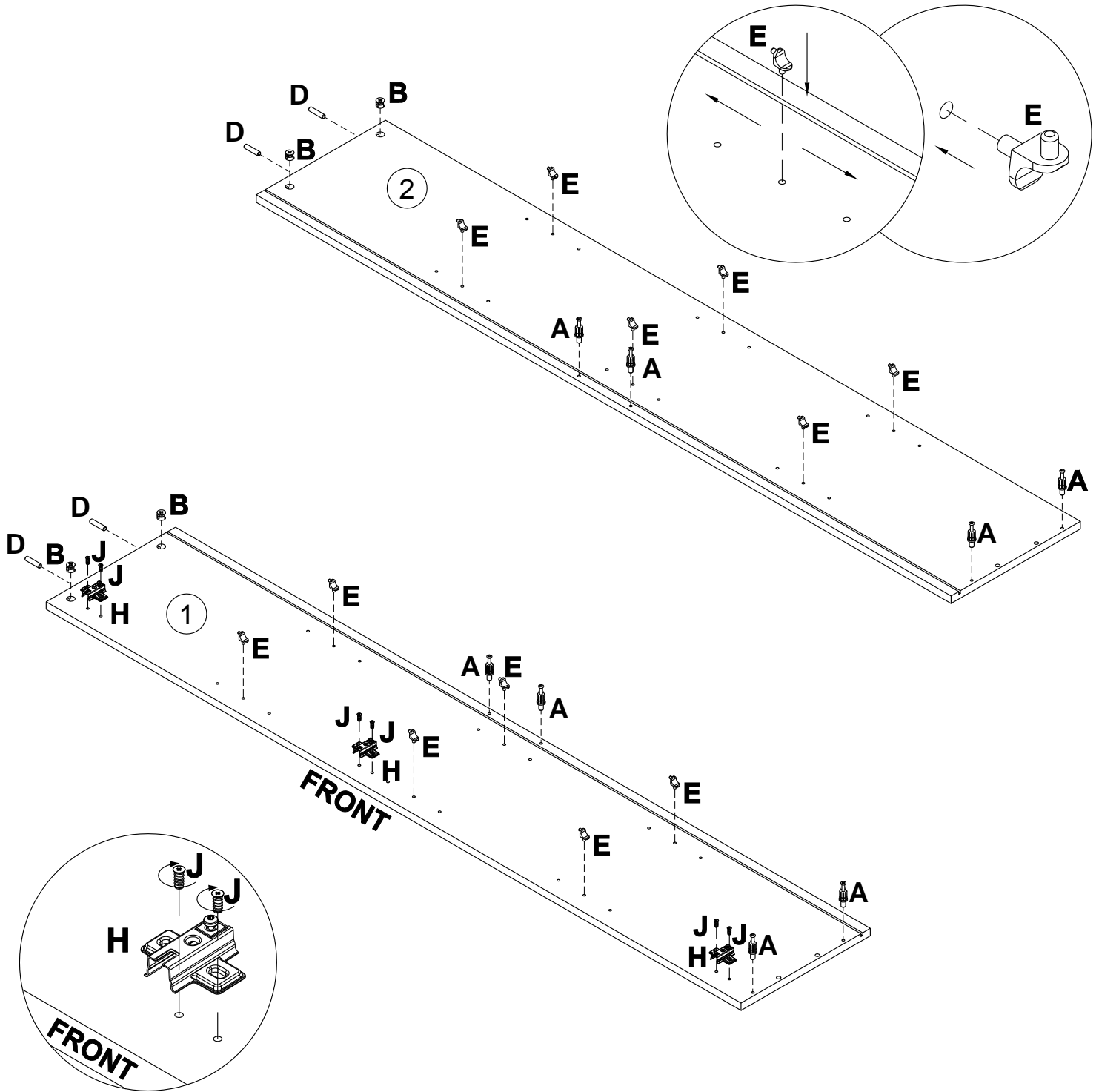

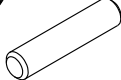
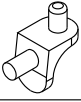
B 000146  15x12 x4	D 000151  8x35 x4	E 125913  x12
---	--	--

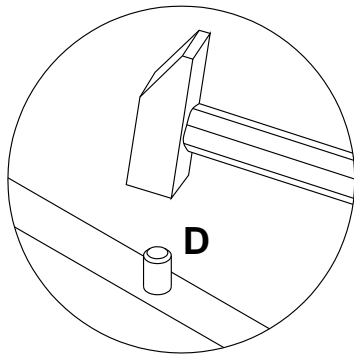
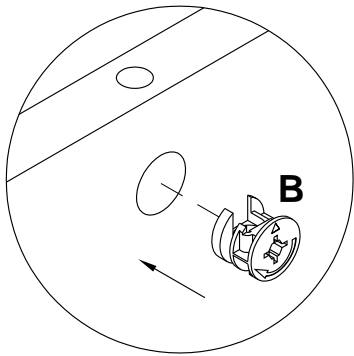
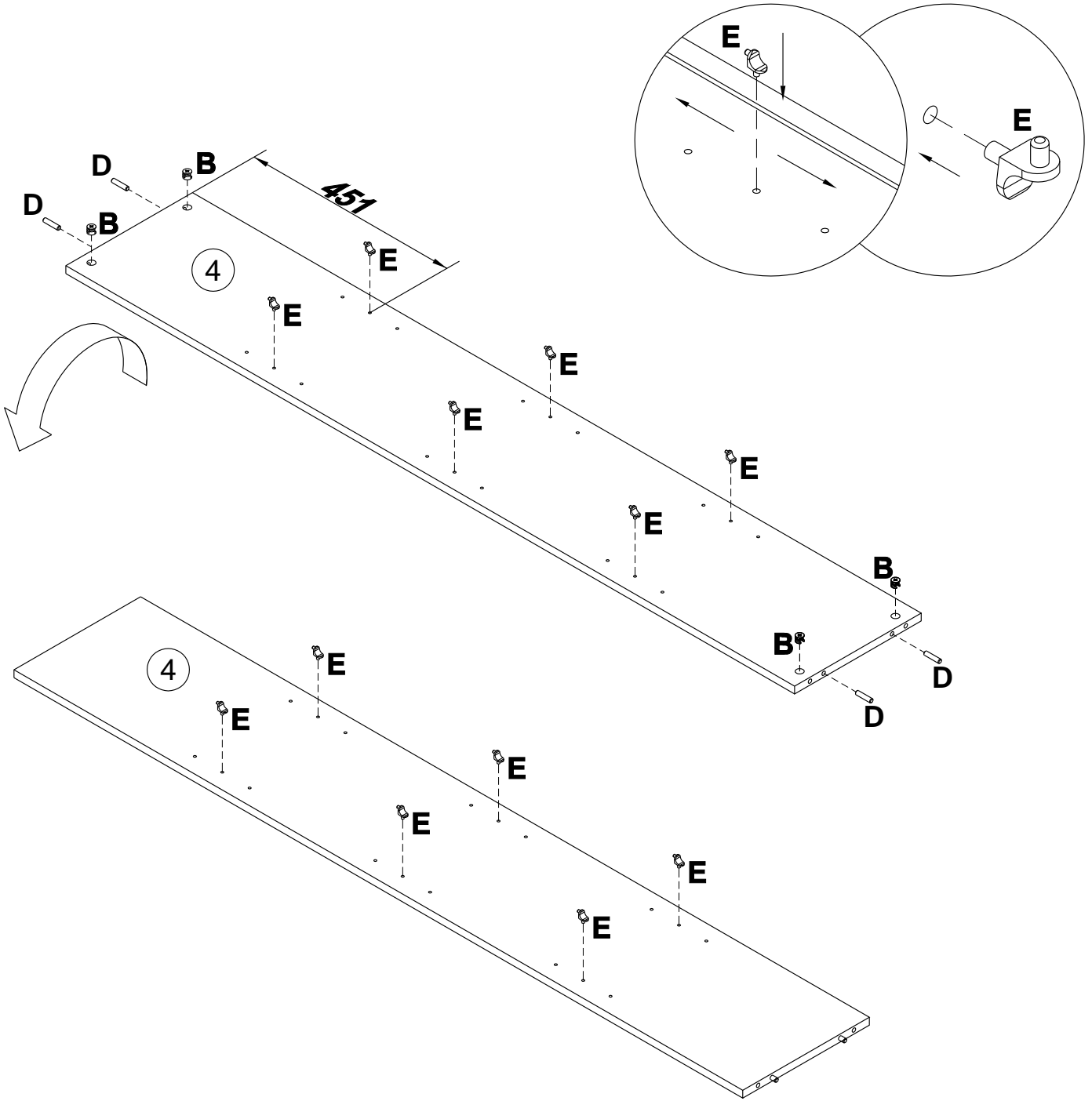

3

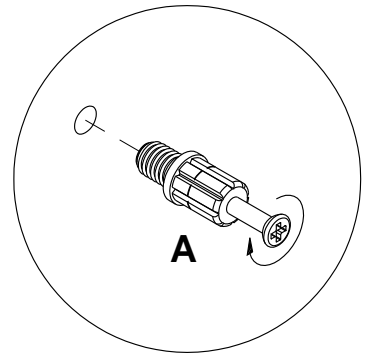
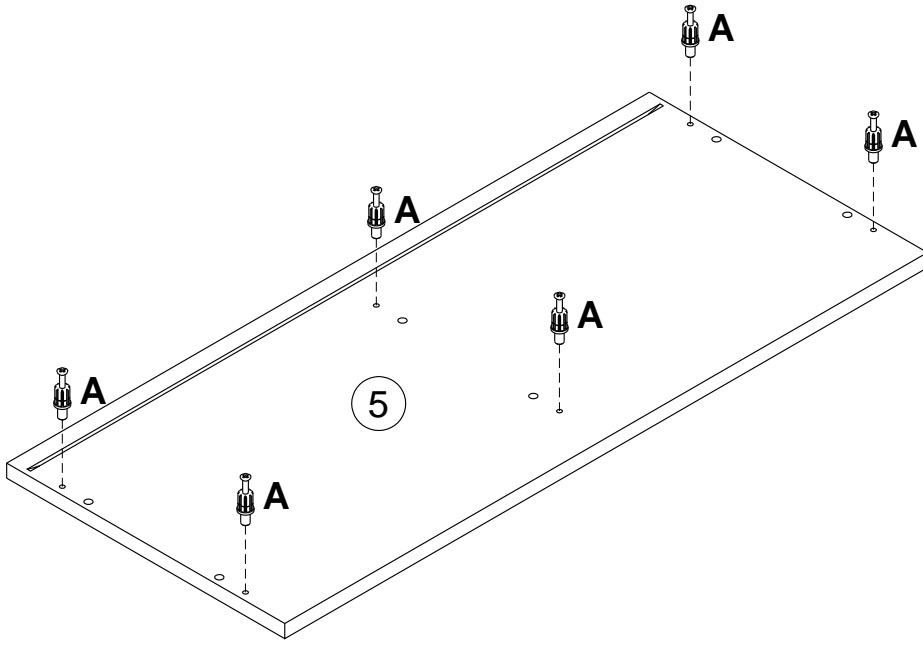
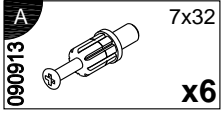

4

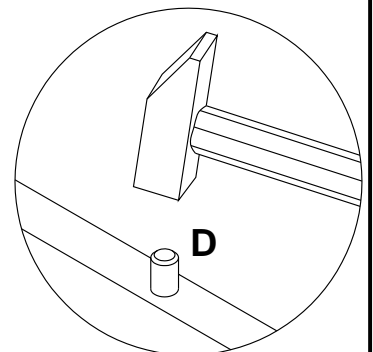
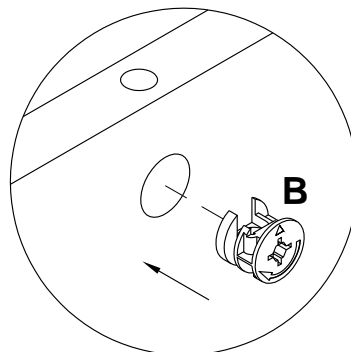
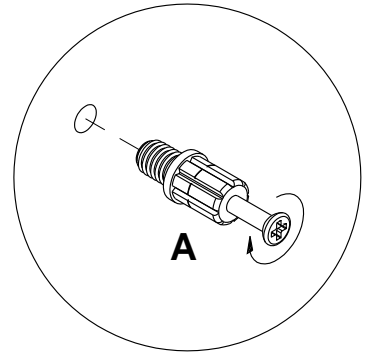
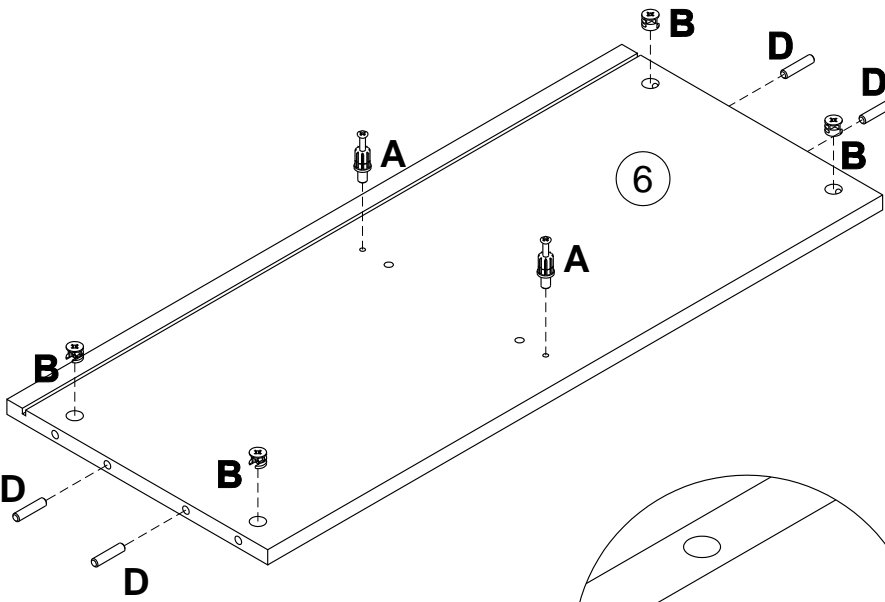
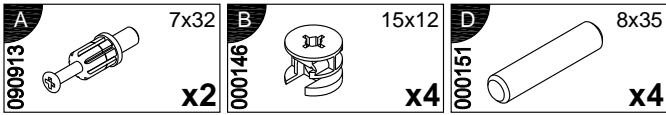

6

5

000146		15x12
		x4

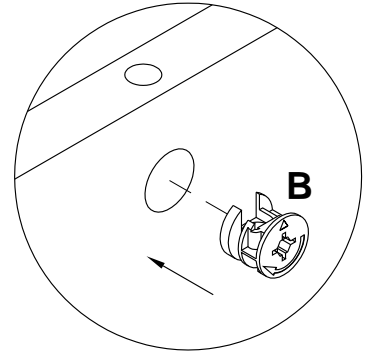
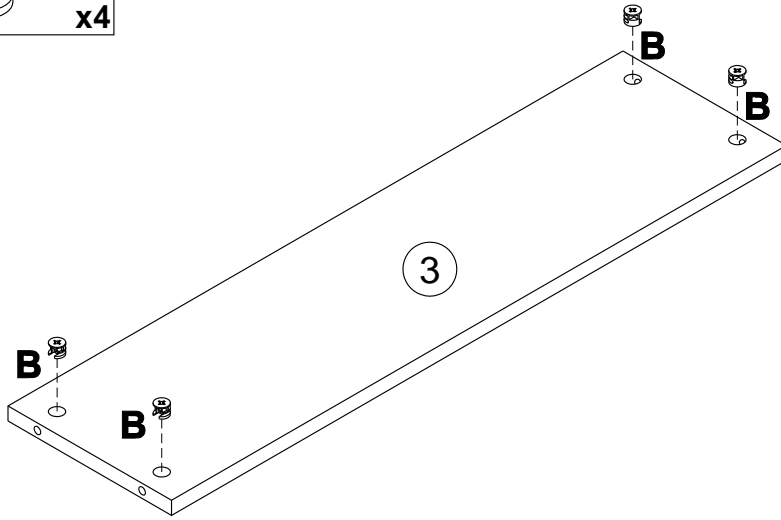

6

000759		3x20
		x10

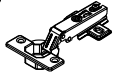
168982		3
		x3

010942		4x16
		x6

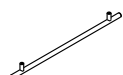
235618		1
		x1

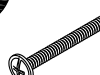
030954		M4x45
		x2

036986		10
		x10

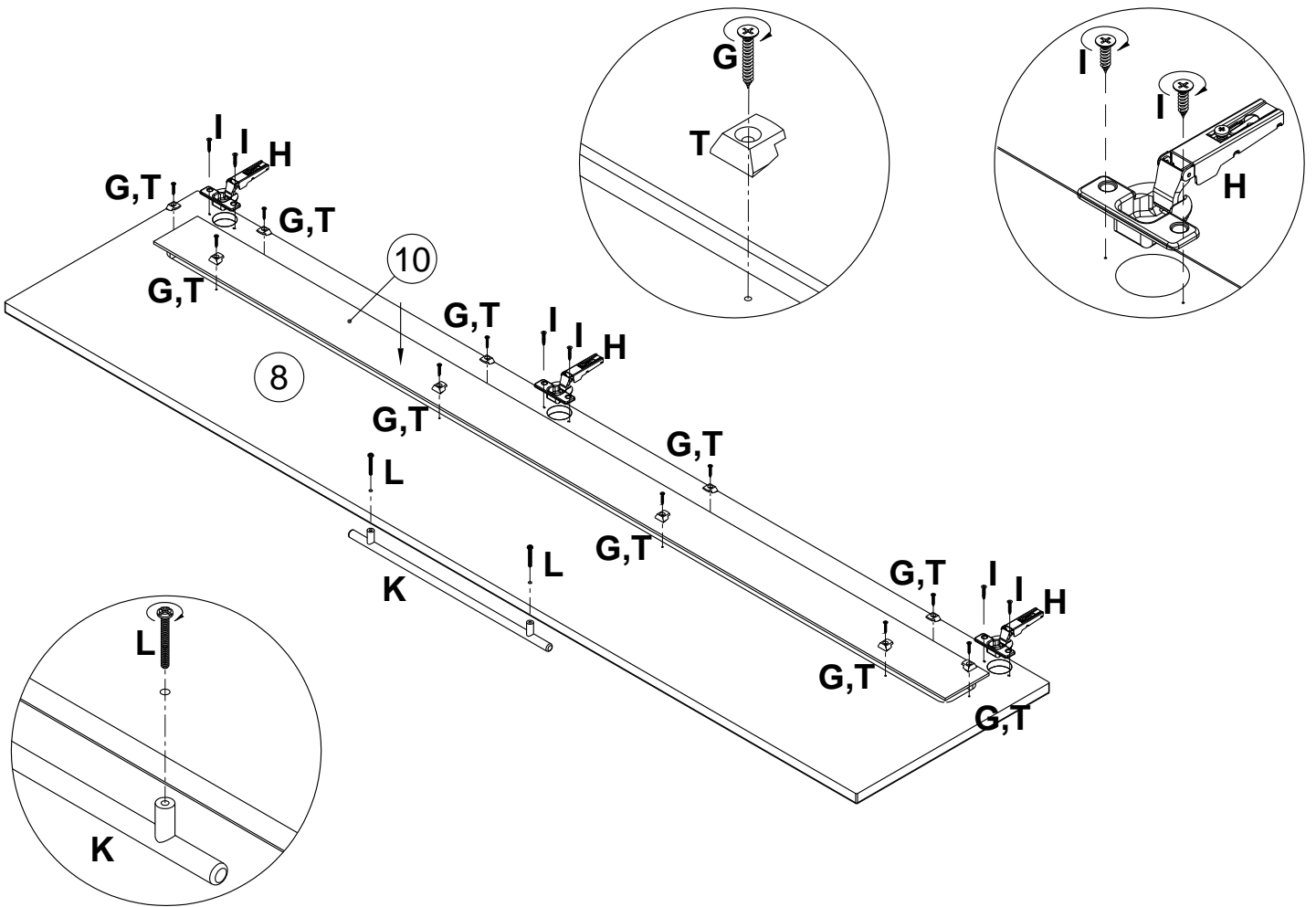

7

7

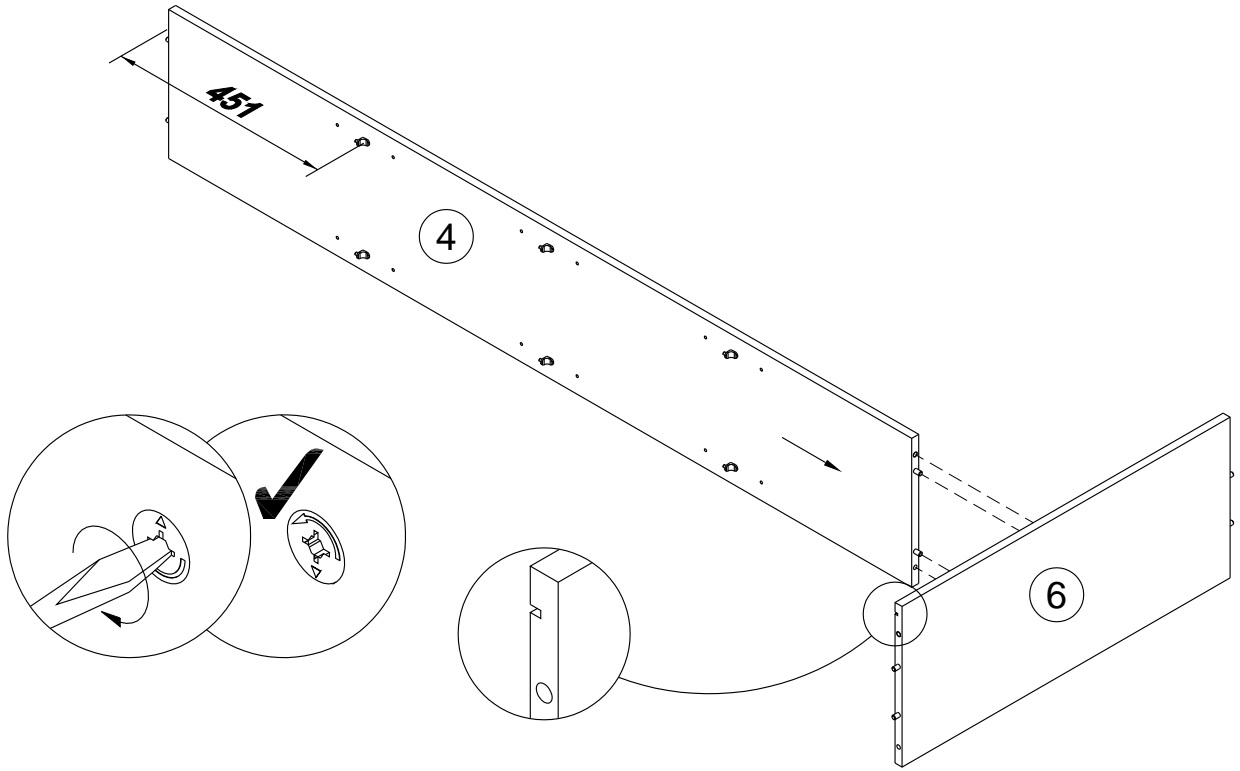

8

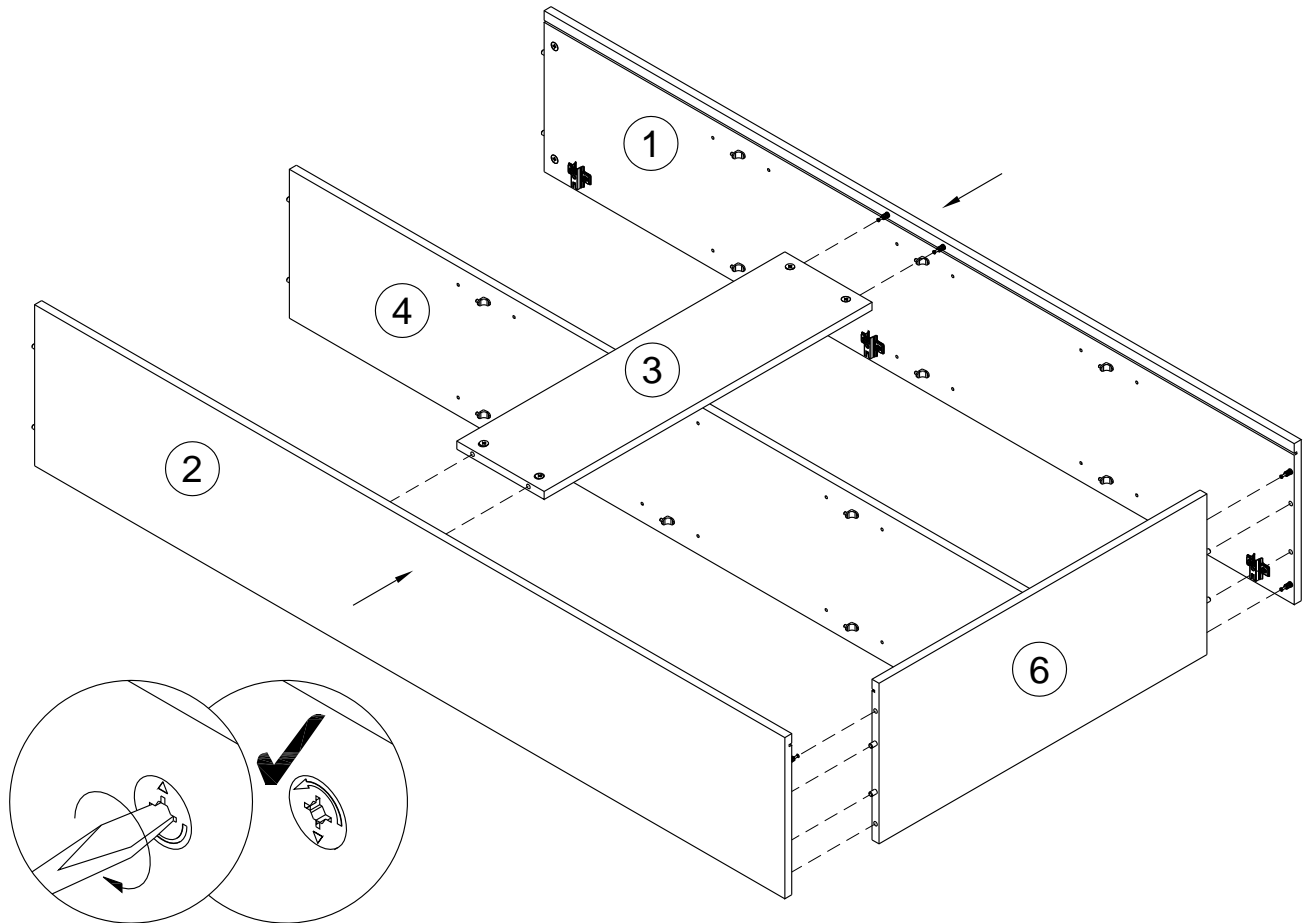

8

9

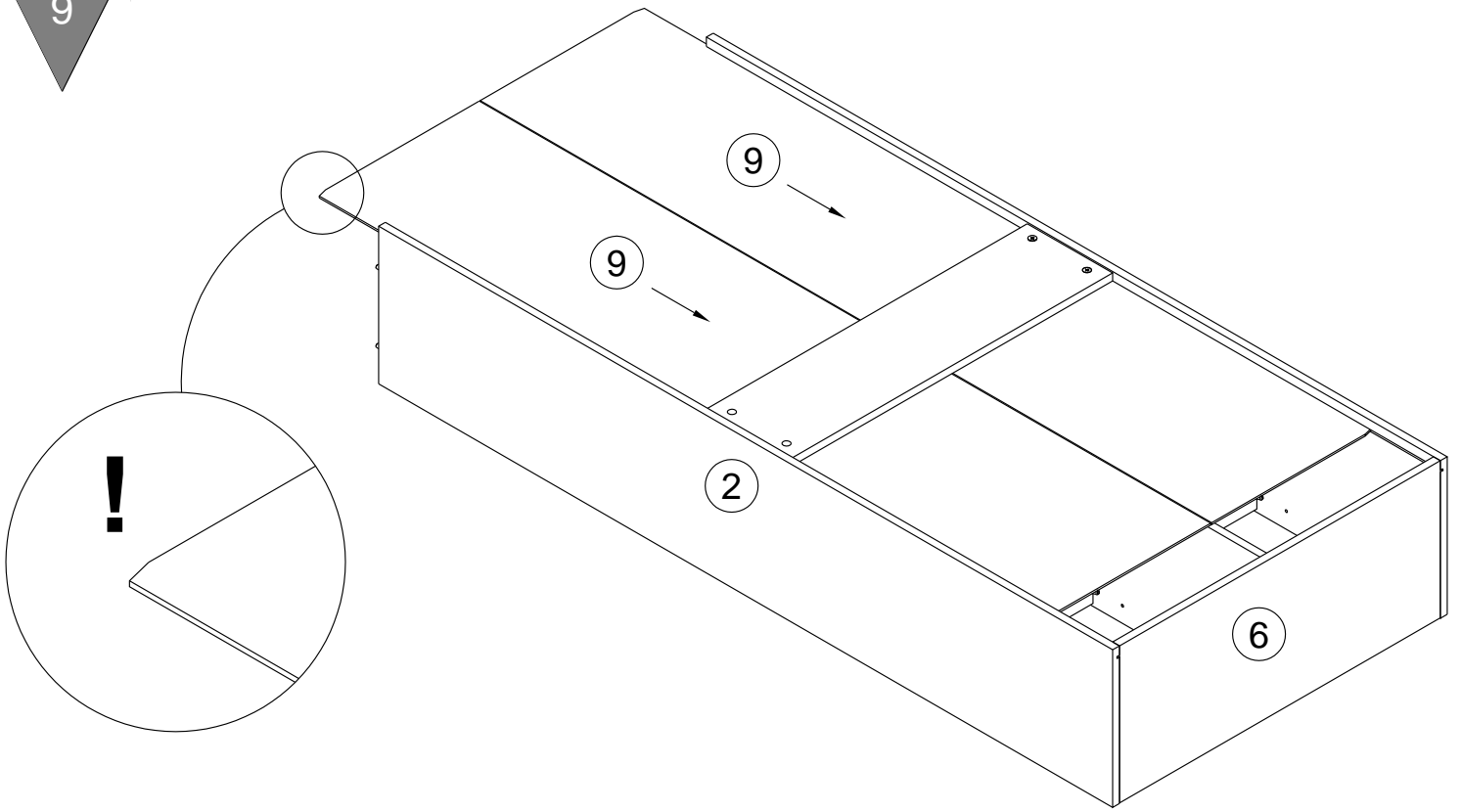

10

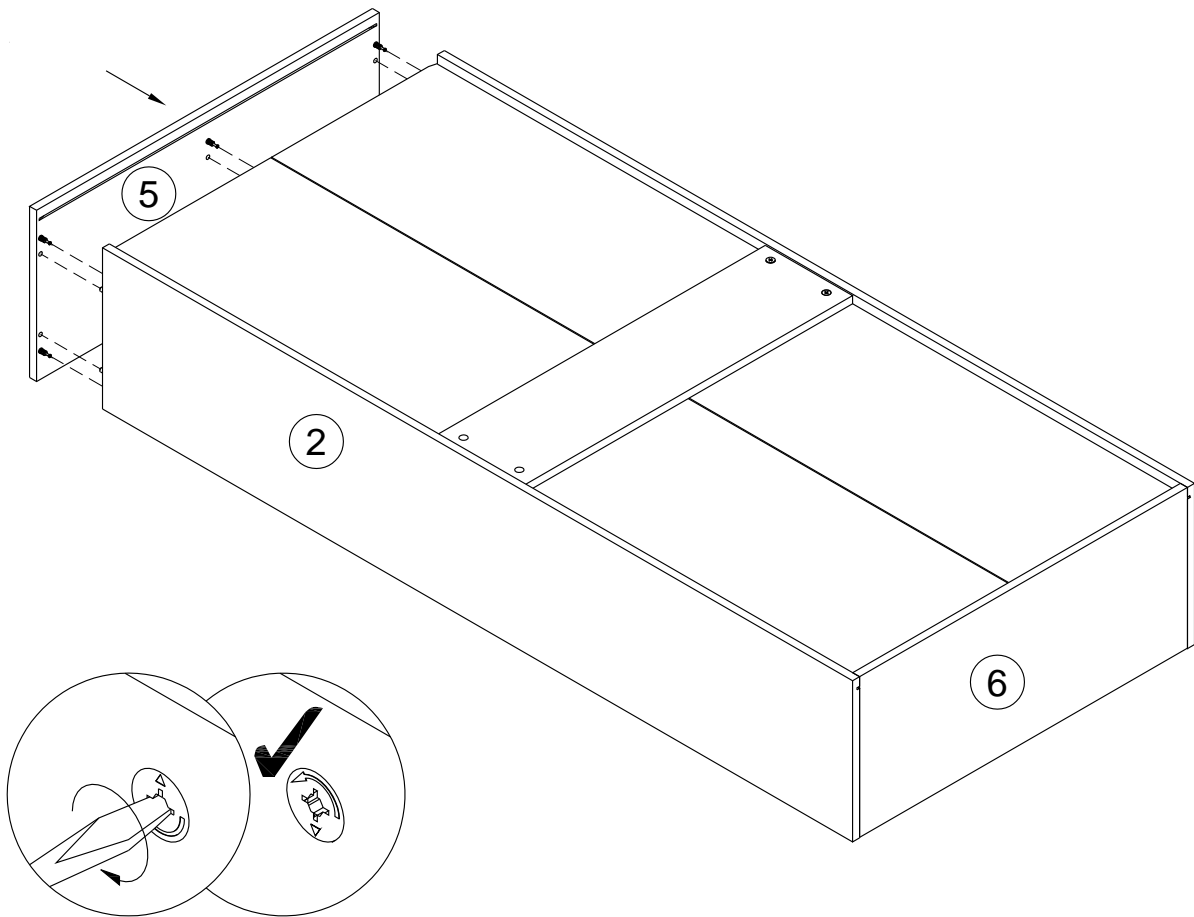



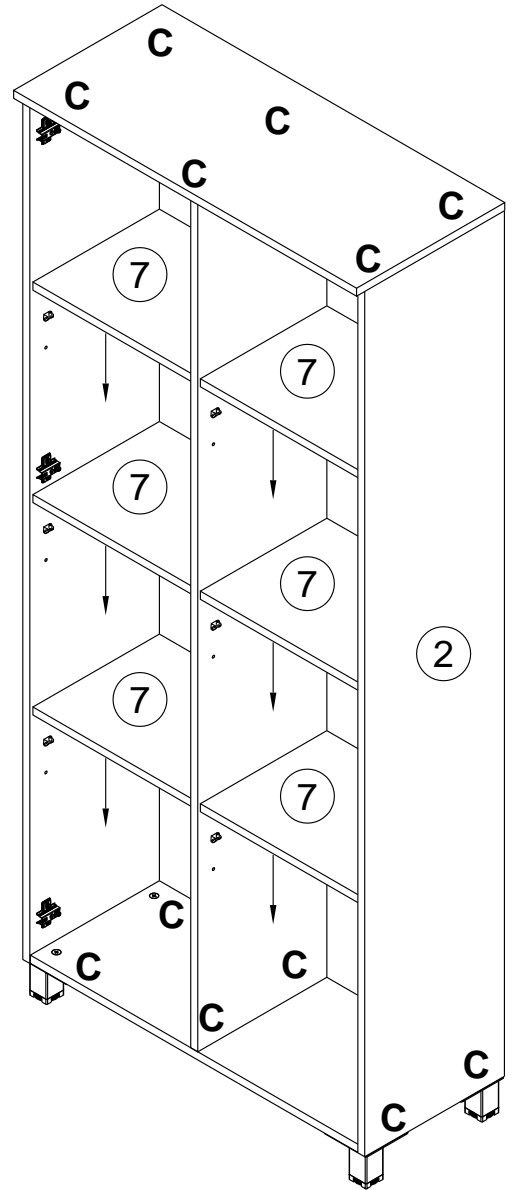
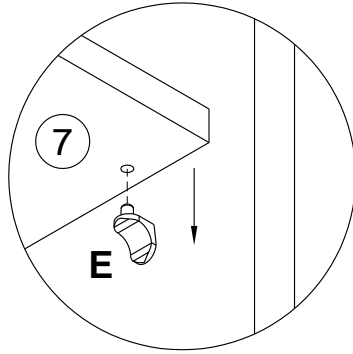
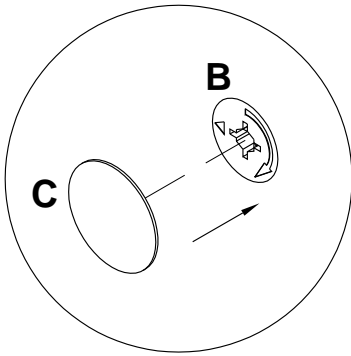

9

12

100640 C 20x0.5 x12

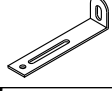

13

- O** 155999  x1
- P** 000754  3.5x16 x2
- Q** 090185  4.5x45 x1
- R** 013859  8x40 x1

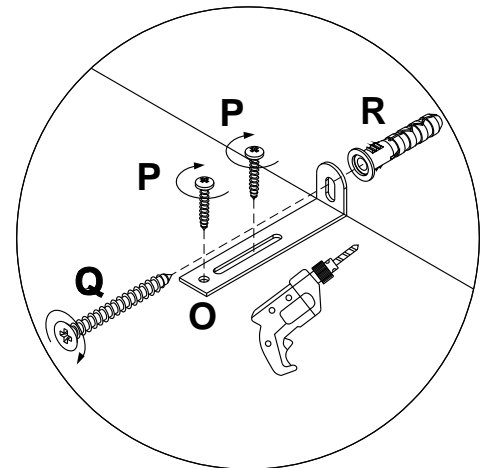
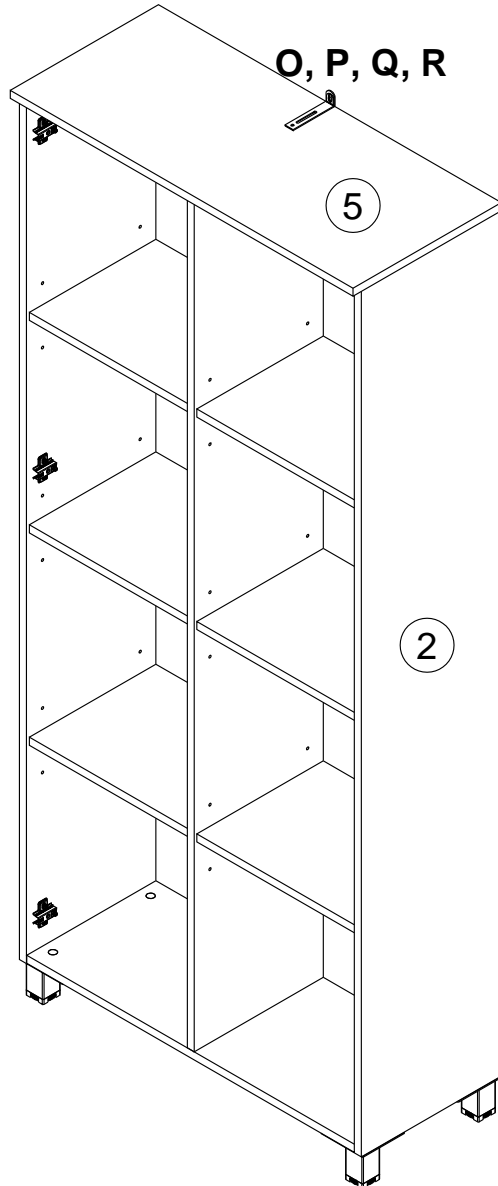

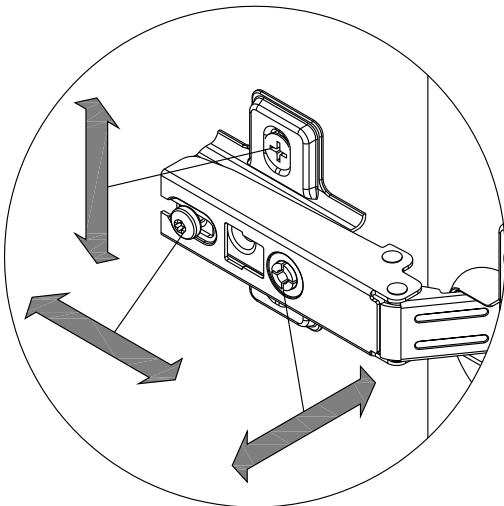
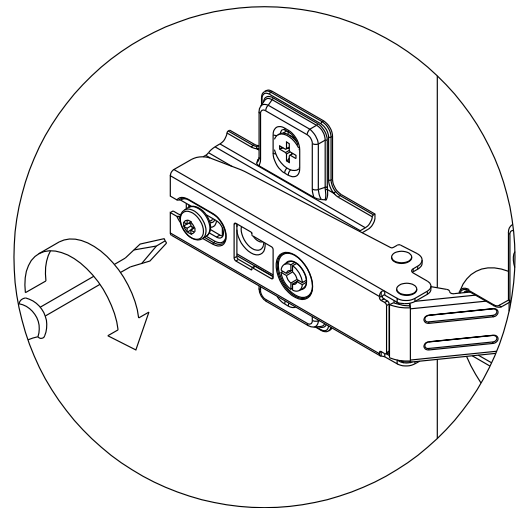
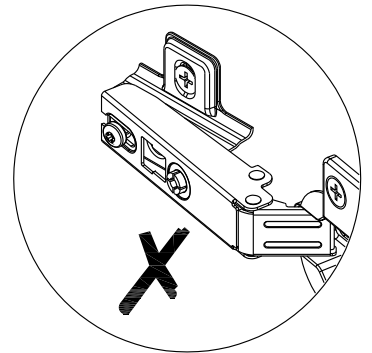
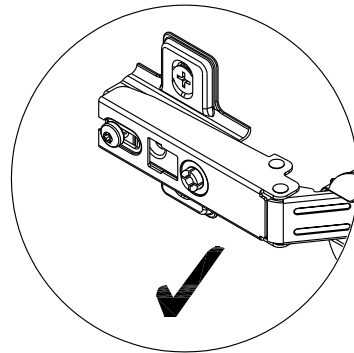
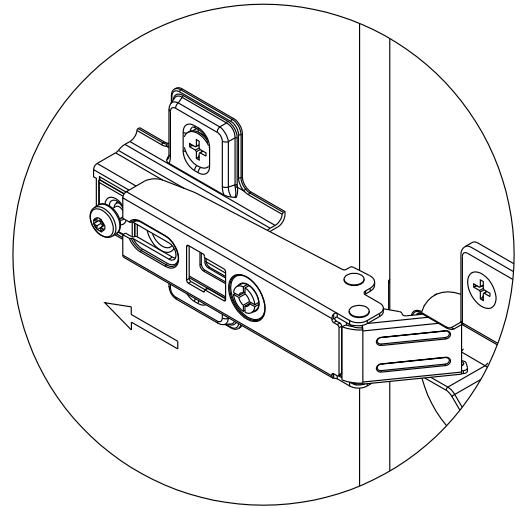
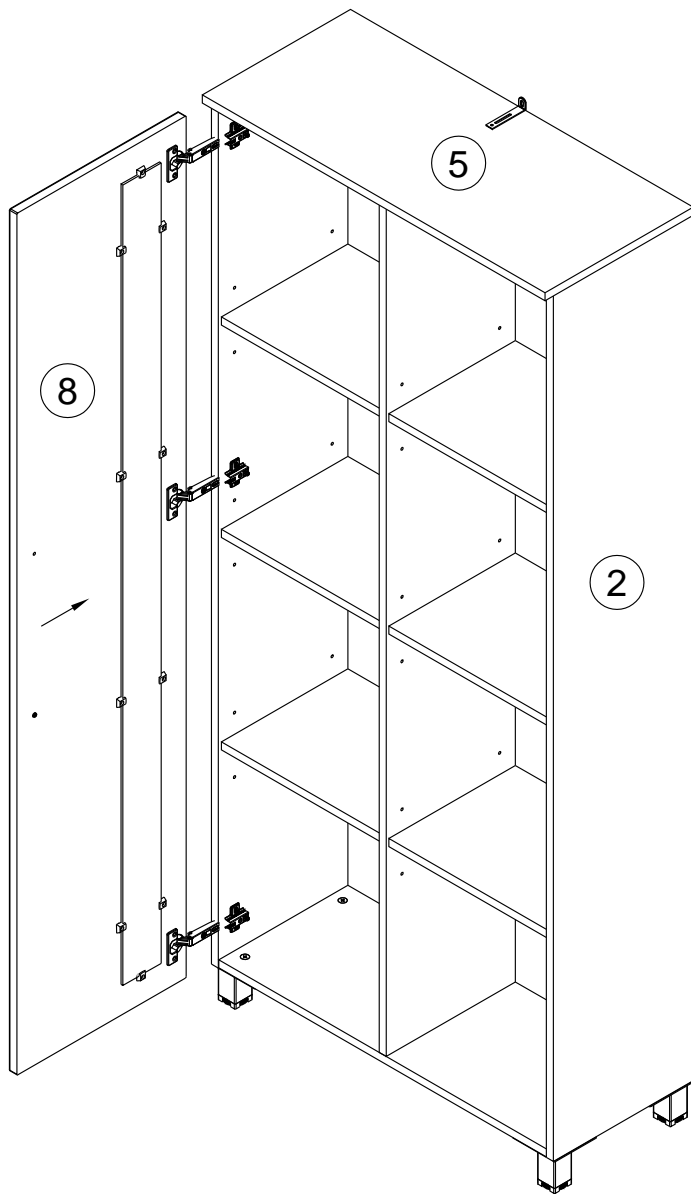

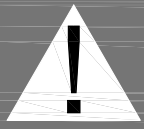

Achtung • Attention • Attenzione
Opgelet • Uwaga • Pozor • Figyelem
Atenție • Dikkat • Внимание



(D)	Wandbefestigung dient als Kippschutz – unbedingt anbringen! Bei einigen Wandtypen kann ein Spezialdübel erforderlich sein!
(GB)	The wall fastening serves to prevent tipping – be absolutely sure to mount it! For certain wall types, a special wall plug may be necessary!
(FR)	La fixation murale sert de protection contre le basculement – à installer impérativement ! Pour certains types de murs il faut des chevilles spéciales !
(IT)	Il fissaggio alla parete serve da protezione anti-ribaltamento – attaccarla assolutamente ! Per alcune strutture di parete può essere necessario un tassello speciale !
(NL)	Bevestiging aan de muur dient als kantelbescherming – zeker en vast bevestigen ! Bij enkele muurtypes is een speciale plug misschien vereist !
(PL)	Mocowanie do ściany jest jednocześnie zabezpieczeniem przed przewróceniem – koniecznie zamontować! Do niektórych rodzajów ścian koniecznie zastosować specjalne kołki mocujące.
(CZ)	Montáž na stěnu slouží jako ochrana proti převrhnuti – bezpodmienečně umístěte! Uněkterých typů stěn může být zapotřebi speciální hmoždinka !
(SK)	Upevnenie na stenu slúži ako ochrana proti prevráteniu – bezpodmienečne použite! Pre niektoré druhy stien môže byť potrebná špeciálna hmoždenka !
(HU)	A terméket a falhoz kel rögzíteni, különben az felborulhat! Egyes faltípusoknál speciális tiplit kell használni !
(RO)	Sistemul de fixare la perete servește ca protecție la răsturnare – de montat obligatoriu! Pentru unele tipuri de pereți este posibil să fie necesar un diblu special !
(TR)	Duvardaki sabitleme, devrilmeye karşı bir emniyet tedbiridir ve mutlaka monte edilmelidir! Bazı duvar tiplerinde bunun için özel bir dübel gerekli olabilir !
(RU)	Обязательно установите крепление на стене во избежание опрокидывания ! Для некоторых типов стен может потребоваться специальный дюбель !