

AMY SANDBOX WITH STORAGE



Sandbox / Sandkasten / Zandbak /
Bac à sable / Arenero / Sabbiera



INSTRUCTION MANUAL

Keep instructions for later use

GEBRAUCHSANWEISUNG

Anleitung zum späteren Gebrauch aufbewahren

GEbruIKSHANDLEIDING

Handleiding bewaren voor later gebruik

MODE D'EMPLOI

Conserver la notice pour usage ultérieur

MANUAL DE USUARIO

Guardar estas Instrucciones para su uso future

ISTRUZIONE PER L'USO

Conservare l'istruzioni per uso successivo



8 717973 937180

Article number /
Artikelnummer /
Artikelnummer /
Numéro d'article /
Número de artículo /
Codice articolo

A031.005.00



WARNING



Have Fun!

Pragma

the multi-brand company



AMY SANDBOX WITH STORAGE



! NOTICE



WARNING

CHOKING HAZARD

Small parts. Not suitable for children under 36 months.



WARNING

THE PRODUCT IS TO BE ASSEMBLED BY AN ADULT.



WARNING

Potential hazard description, e.g. In unassembled state contain potentially hazardous sharp points, so please keep out of baby's reach.

Only for domestic outdoor use.
Retain for future reference.



WARNUNG

VERSCHLUCKUNGSGEFAHR

Kleine Teile. Für Kinder unter 3 Jahren nicht geeignet.



WARNUNG

DAS PRODUKT IST VON EINEM ERWACHSENEN ZUSAMMENGEBAUT WERDEN.



WARNUNG

Beschreibung potenzieller Gefahr, z.B. in nicht zusammengesetztem Zustand enthält es potenziell gefährliche scharfe Spitzen, daher von Babys fernhalten!

Nur für den häuslichen Gebrauch im Außenbereich.
Diese Informationen aufheben.



WAARSCHUWING

VERSTIKKINGSGEVAAR

Kleine onderdelen. Niet geschikt voor kinderen onder de 36 maanden.



WAARSCHUWING

HET PRODUCT MOET DOOR EEN VOLWASSEN GEMONTEERD WORDEN.



WAARSCHUWING

Beschrijving potentieel gevaar, bv in ongemonteerde toestand bevat het potentieel gevaarlijke punten, zorg ervoor dat baby's er niet bij kunnen.

Alleen geschikt voor particulier buiten gebruik.
Bewaar deze informatie.

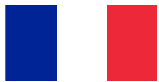

AVERTISSEMENT

RISQUE D'ÉTOUFFEMENT

Petit matériel. Ne convient pas pour les enfants de moins de 36 mois.



AVERTISSEMENT

LE PRODUIT DOIT ÊTRE ASSEMBLÉ PAR UN ADULTE.



AVERTISSEMENT

Description de risque potentiel, par exemple, Démonté, contient des pointes potentiellement dangereuses. À conserver hors de portée des enfants en bas âge.

Convient uniquement pour l'utilisation à l'extérieur.
Conserver pour une consultation ultérieure.



ADVERTENCIA

PELIGRO DE ASFIXIA

Piezas pequeñas. No adecuado para menores de 36 meses.



ADVERTENCIA

EL PRODUCTO DEBE SER MONTADO POR UN ADULTO



ADVERTENCIA

Descripción de posible peligro, p. ej.: El producto desmontado contiene posibles puntos afilados, así que debe mantenerse fuera del alcance del bebé

Sólo para uso doméstico en el exterior.
Conservar para futuras consultas.



AVVERTENZA

PERICOLO DI SOFFOCAMENTO

Componenti di piccole dimensioni. Non adatto per bambini di età inferiore a 36 mesi.



AVVERTENZA

IL GIOCATTOLO DEVE ESSERE MONTATO DA UN ADULTO.



AVVERTENZA







Descrizione dei rischi potenziali, ad es. in condizioni smontate contiene parti acuminate potenzialmente pericolose; tenere quindi fuori dalla portata del bambino.

Esclusivamente per uso domestico all'aperto.
Conservare per riferimento futuro.

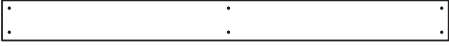
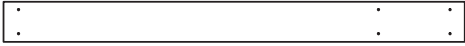
AMY SANDBOX WITH STORAGE

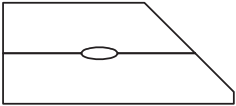
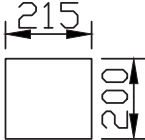

PARTS

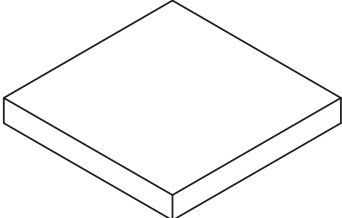
1		x4
2		x4
3		x2
4		x2
5		x1
6		x6
7		x4
A	 3.5x40mm	x68
B		x1

AMY SANDBOX WITH STORAGE



ASSEMBLY

1

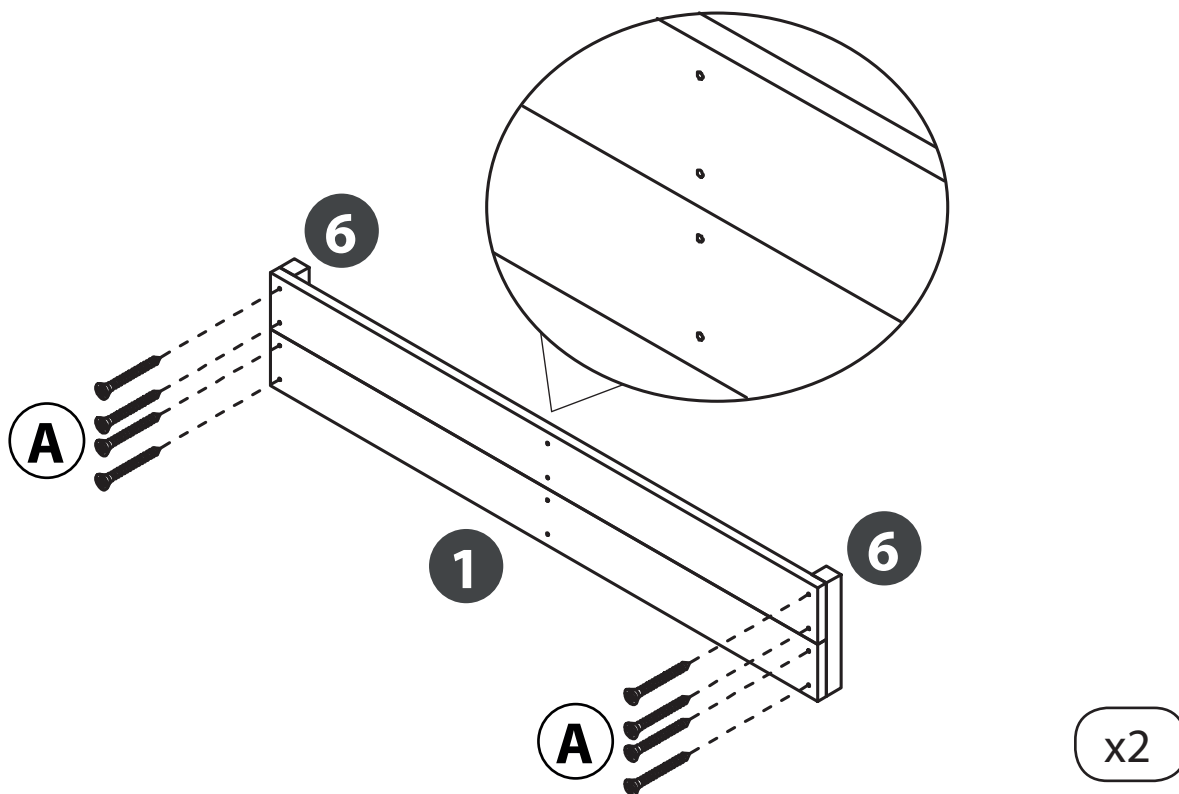

2

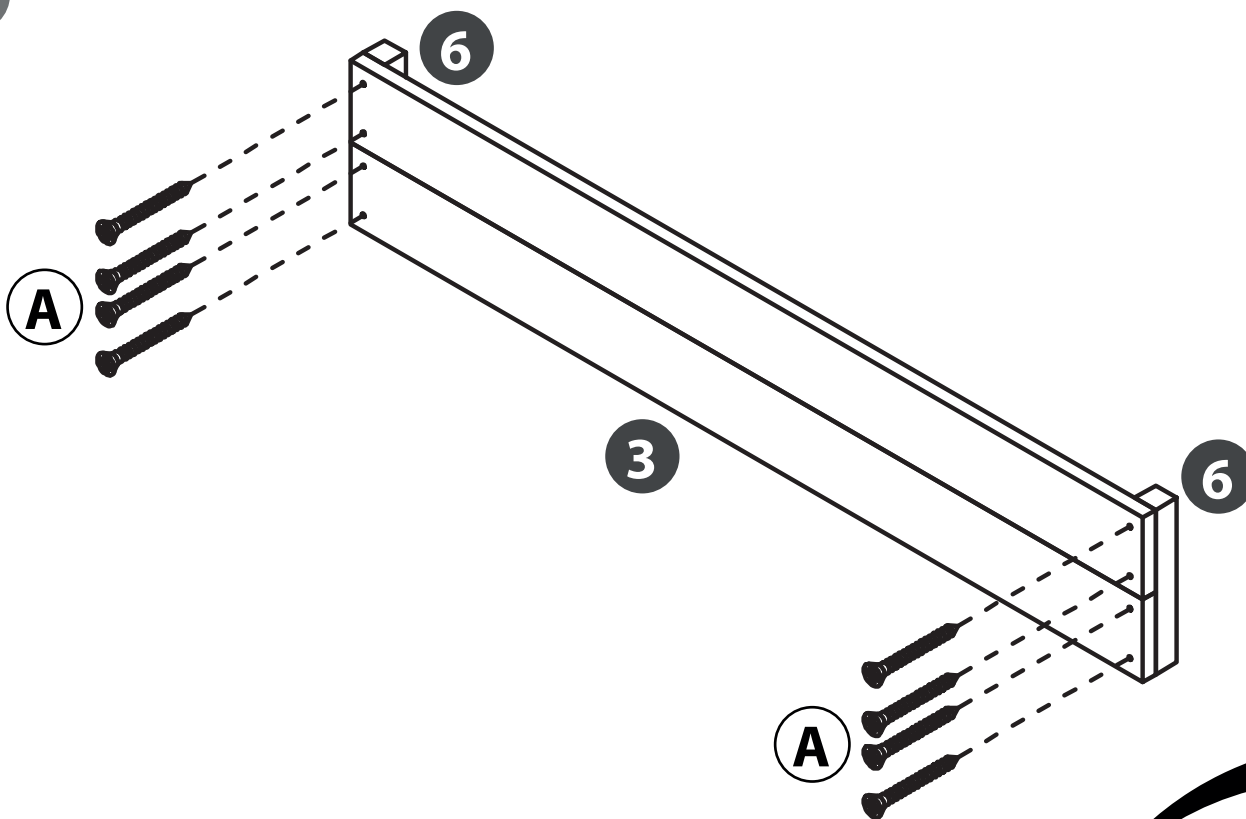

AMY SANDBOX WITH STORAGE



ASSEMBLY

3

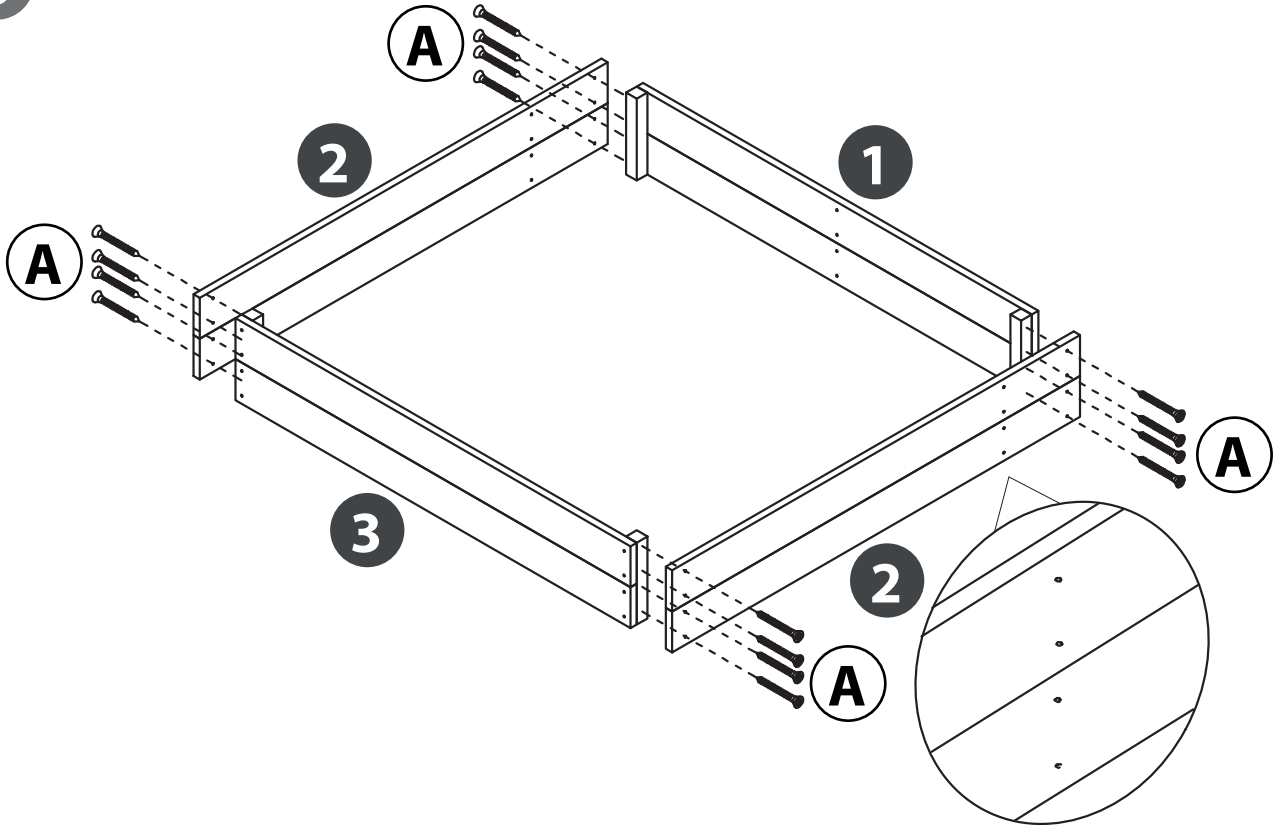

4

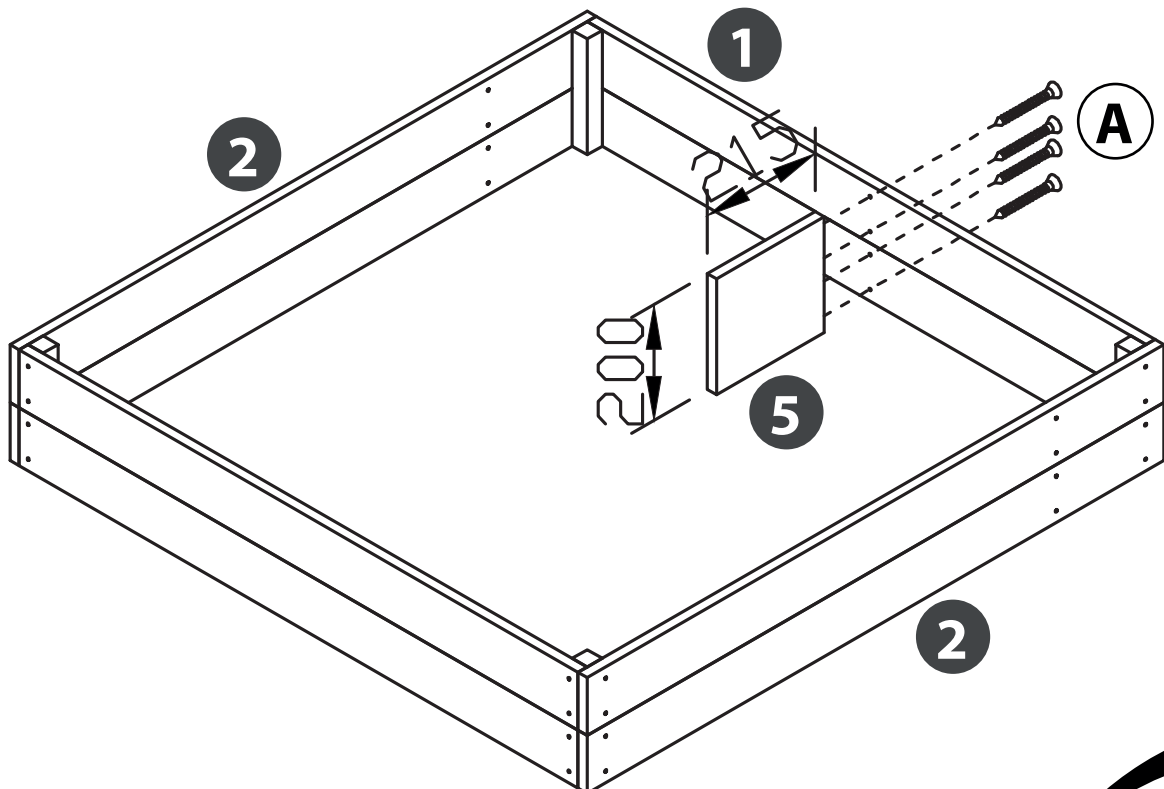

Have Fun!

AMY SANDBOX WITH STORAGE



ASSEMBLY

5

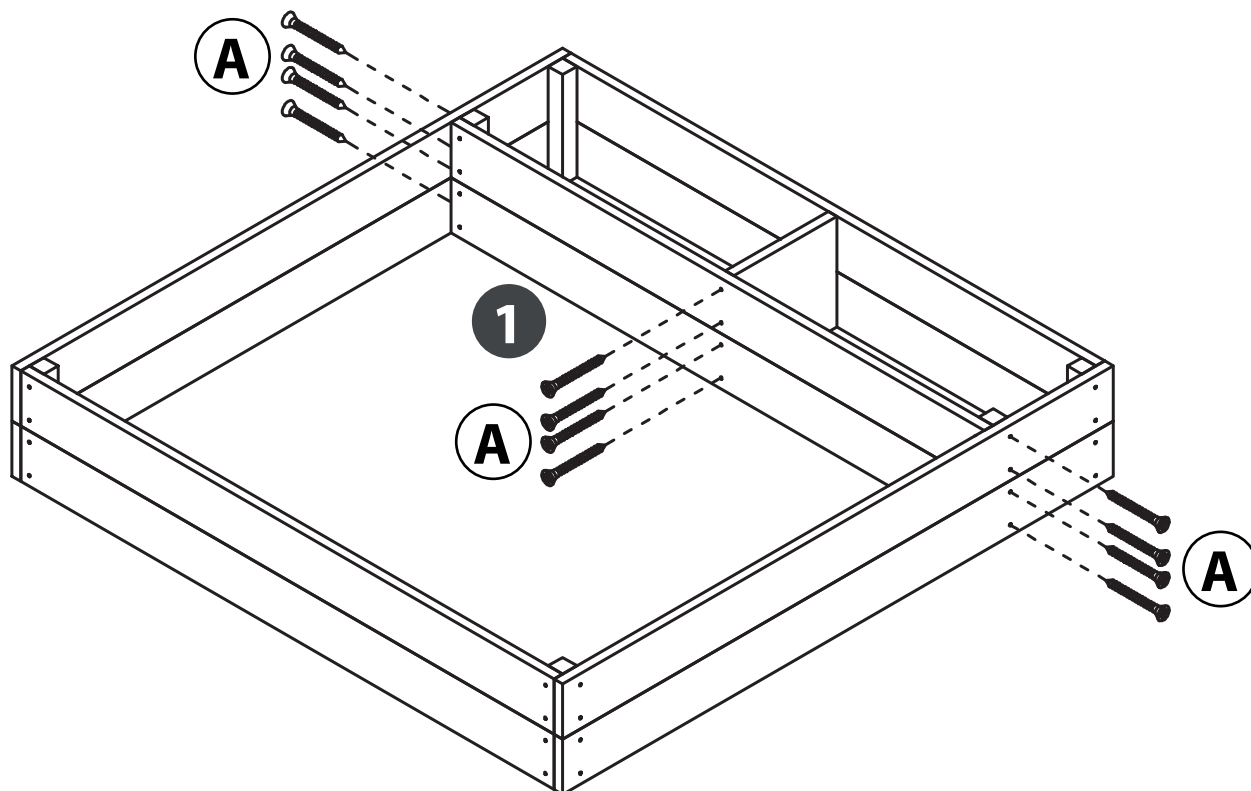

6

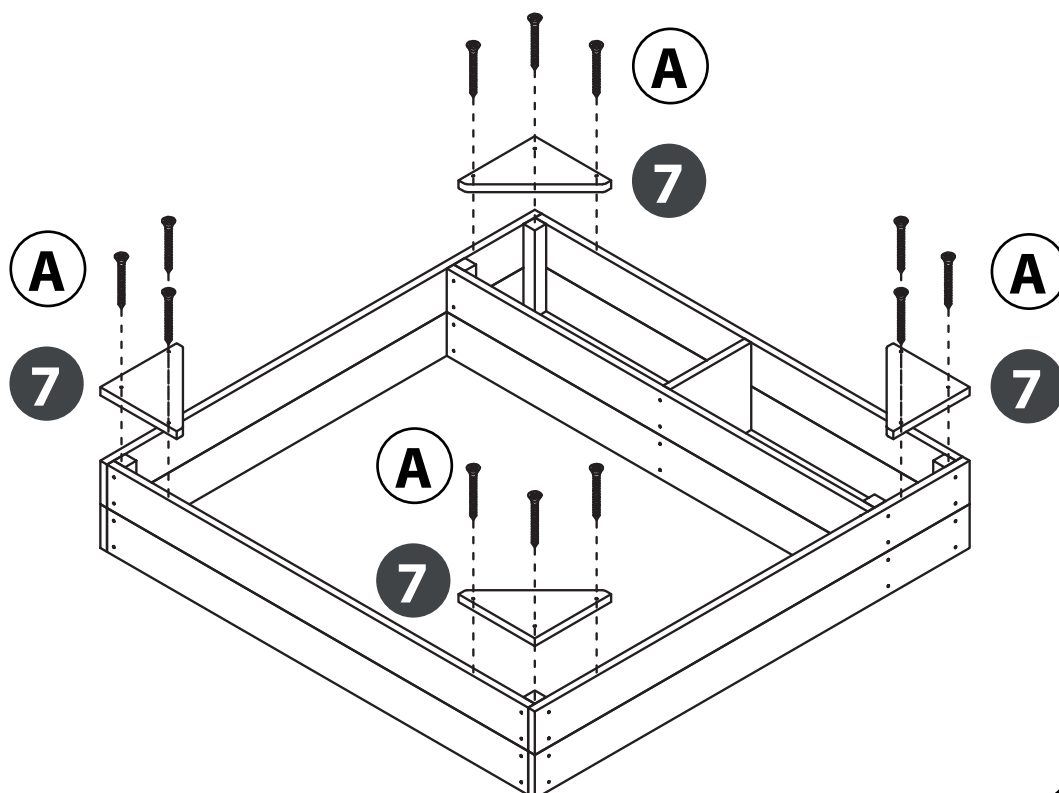

Have Fun!

AMY SANDBOX WITH STORAGE



ASSEMBLY

7

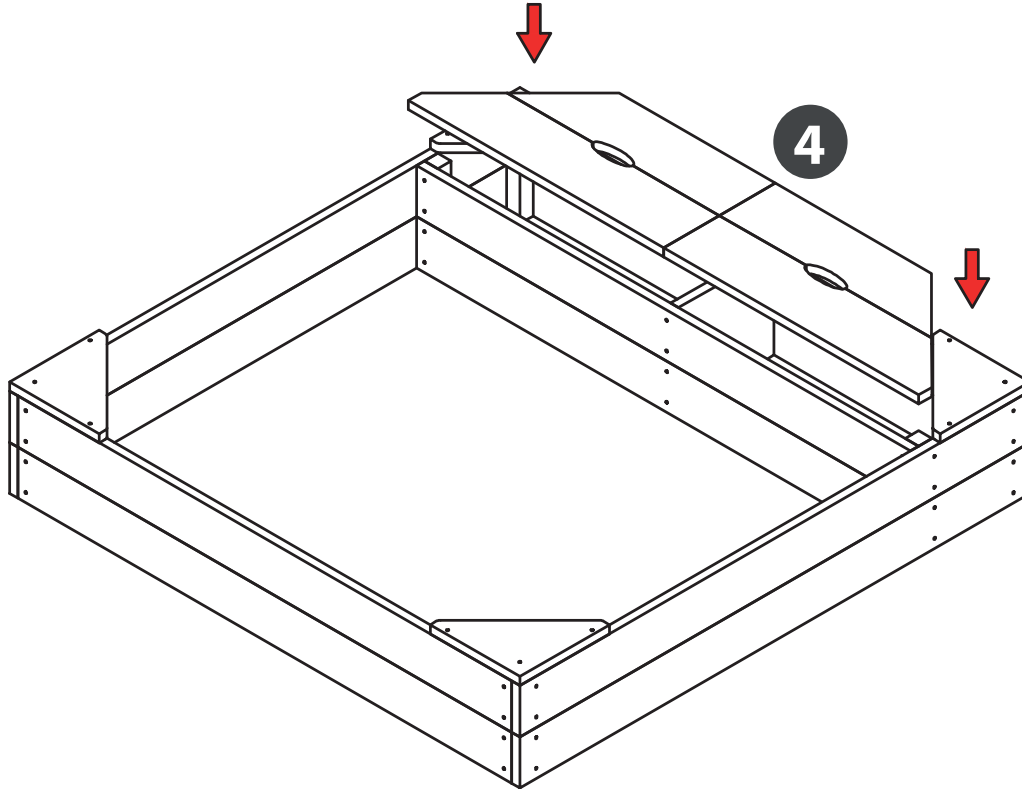

8

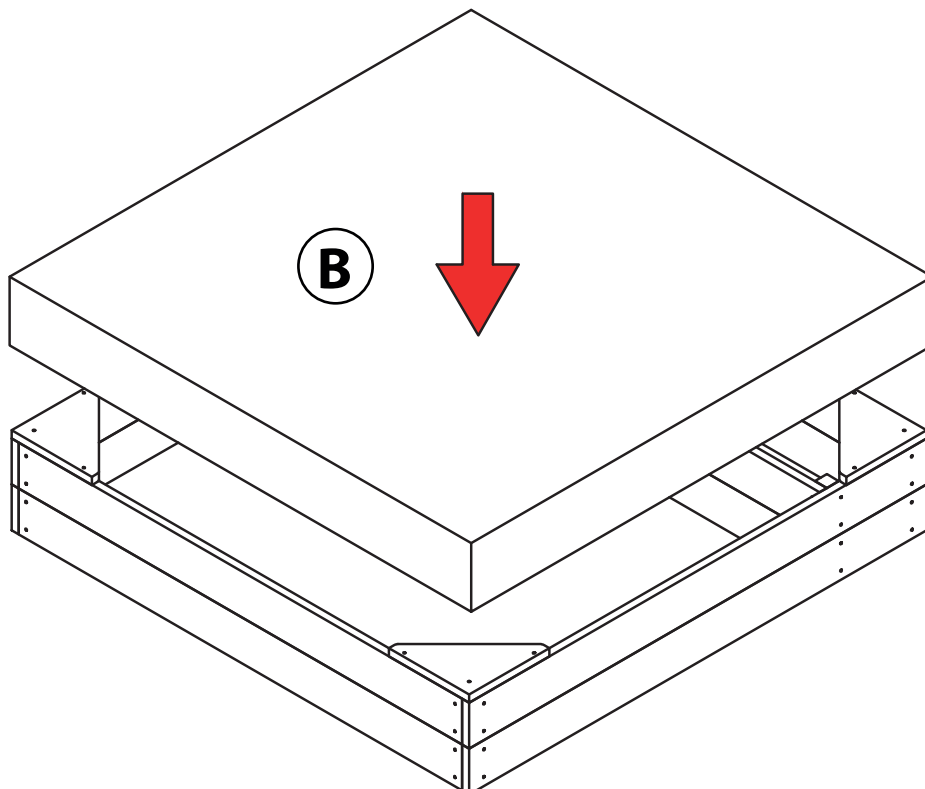

Have Fun!

AMY SANDBOX WITH STORAGE



PLACEMENT

PLACEMENT

Place the AXI Amy on a flat surface and at least 2.00 metres away from other structures and other obstacles such as house walls, garage, fence, overhanging branches or laundry lines. It is necessary to carry out checks and maintenance of the main parts at regular intervals, pointing out that if these checks are not carried out the toy could overturn or otherwise become a hazard. It's of a particular importance that the maintenance instructions are followed at the beginning of each season as well as at regular intervals during the usage season.

PLATZIERUNG

Stellen Sie das AXI Amy auf einem flachen Untergrund auf und halten Sie einen Abstand von mindestens 2 m zum nächsten Bau oder Hindernis, wie Haus, Garage, Zaun und überhängende Zweige oder Wäscheleinen, ein. Es müssen regelmäßige Prüfungen und Wartungsarbeiten an den Hauptteilen erfolgen. Wenn diese Prüfungen nicht durchgeführt werden, könnte das Spielzeug kippen oder anderweitig eine Gefahr darstellen. Es ist besonders wichtig, dass die Wartungsanweisungen zu Beginn jeder Saison und in regelmäßigen Abständen bei der Nutzung während der Saison befolgt werden.

PLAATSING

Plaats de AXI Amy op een vlakke ondergrond en minimaal 2.00 meter uit de buurt van andere bouwwerken en obstakels zoals een huis, garage, hek en overhangende takken of waslijnen. Het is noodzakelijk de hoofdonderdelen op regelmatige basis te controleren en te onderhouden, en erop te wijzen dat, indien deze controles niet worden uitgevoerd, het speelgoed kan omvallen of op andere wijze gevaar kan opleveren. Het is van het grootste belang dat de onderhoudsinstructies worden opgevolgd, aan het begin van het seizoen en daarnaast regelmatig tijdens het gebruikseizoen.

PLACEMENT

Posez le AXI Amy sur une surface plane et gardez une distance d'au moins 2 mètres des autres édifices et obstacles, comme les maisons, garages, barrières, branches et cordes à linge. Des vérifications et une maintenance des parties principales du jouet doivent régulièrement avoir lieu, sinon le jouet risque de se renverser ou de devenir dangereux. Il est capital de respecter scrupuleusement les instructions et les intervalles de maintenance au début de chaque saison, et au cours de la saison d'utilisation.

COLOCACIÓN

Coloque le AXI Amy sobre una superficie plana y a una distancia mínima de 2 metros de otros edificios u obstáculos, como por ejemplo casas, garajes, vallas y ramas inclinadas o tendedores. Es necesario realizar comprobaciones y tareas de mantenimiento en las piezas principales a intervalos regulares. En caso contrario, el juguete podría volcar o constituir un peligro. Es de especial importancia seguir las instrucciones de mantenimiento al inicio de cada temporada y a intervalos regulares durante la temporada de uso.

POSIZIONAMENT

Posizionare le AXI Amy su una superficie piana e a una distanza minima di 2,00 metri da altre costruzioni edili e ostacoli (quali, ad esempio, fabbricati, garage, recinzioni, alberi con rami spioventi o corde per il bucato). È necessario effettuare controlli e la manutenzione dei componenti principali a intervalli regolari; si ricorda che in mancanza di tali controlli il giocattolo potrebbe capovolgersi o provocare altri pericoli. È particolarmente importante seguire le istruzioni di manutenzione all'inizio di ogni stagione e a intervalli regolari durante la stagione di utilizzo.

AMY SANDBOX WITH STORAGE



MAINTENANCE

MAINTENANCE

Check whether all the nuts are on the bolts and whether there are any sharp edges, replace part as necessary. It is necessary to check regularly for splinters, loose screws and the tightness of joints and/or fastenings. If necessary, nuts and bolts must be tightened. 'Regularly means: when you put it up and twice a month during the outdoor play season. Once a year check the state of the protective stain layer. To ensure the optimum durability, the AXI Amy needs to be given a new coat of stain every two years. Use a water-based paint / stain based on natural components for this.

WARTUNG

Prüfen Sie, ob alle Muttern auf den Schrauben sitzen und keine scharfen Ränder haben. Tauschen Sie diese gegebenenfalls aus. Das Sandbox muss regelmäßig nach Splintern, Schrauben und der Festigkeit der Verbindungen und/oder Befestigungen kontrolliert werden. Falls notwendig, müssen Schrauben und Muttern festgezogen werden. Mit regelmäßig ist gemeint: in der Draußenspielsaison mindestens zwei Mal pro Monat. Kontrollieren Sie jährlich den Zustand der Beizschicht. Für optimale Haltbarkeit muss das AXI Amy einmal in zwei Jahren neu mit Beize behandelt werden. Verwenden Sie dazu eine wasserlösliche Farbe oder Beize auf natürlicher Basis.

ONDERHOUD

Controleer of alle moeren op de bouten zitten en of er geen scherpe randen zijn, vervang onderdeel indien nodig. Het is verplicht regelmatig te controleren op splinters, schroeven en de sterkte van verbindingen en/of bevestigingen. Indien van toepassing dienen schroeven en moeren te worden aangedraaid. Onder regelmatig wordt verstaan: bij aanvang van en tweemaal per maand tijdens het buitenspeelseizoen. Controleer jaarlijks de conditie van de beitslaag. Voor een optimale duurzaamheid is het noodzakelijk de AXI Amy eens per twee jaar te voorzien van een nieuwe beitslaag. Maak hierbij gebruik van een watergedragen verf/beits op natuurlijke basis.

ENTRETIEN

Contrôlez si tous les écrous sont montés sur les boulons, s'il n'y a pas d'arêtes tranchantes, et remplacez la pièce au besoin. Il est impératif de contrôler régulièrement s'il y a des éclats de bois qui se détachent, si les vis sont bien serrées et si les raccordements et/ou fixations sont en place et solides. Si nécessaire, serrez les vis et écrous. Périodiquement signifie, dans ce cas : au début de la saison de jeux à l'extérieur, puis deux fois par mois pendant la saison. Annuellement pour la couche de teinture. Afin d'assurer une durabilité optimale, le AXI Amy doit être traitée tous les deux ans. Appliquez une peinture/teinture naturelle à base d'eau.

MANTENIMIENTO

Compruebe que todos los pernos disponen de tuercas y que no tienen bordes afilados. Si es necesario, deberá sustituir la pieza en cuestión. Es obligatorio comprobar de manera regular si hay astillas o tornillos que sobresalen, así como la resistencia de las uniones y/o fijaciones. Si es necesario, deberá apretar más fuerte los tornillos o pernos. Por "regularmente" se entiende: al comienzo de la temporada de juegos al aire libre y, dos veces al mes durante la misma. Compruebe una vez al año el estado de la capa de nogalina. Para una durabilidad óptima es necesario aplicar dos veces al año una nueva capa de nogalina a le AXI Amy. Utilice una pintura o nogalina de base acuosa.

MANUTENZIONE

Verificare che tutti i dadi e i bulloni siano ben posizionati e che non vi siano estremità o bordi affilati. Provvedere alla sostituzione degli elementi se necessario. È obbligatorio verificare a intervalli regolari l'eventuale presenza di schegge nonché il serraggio delle viti, dei giunti e/o degli elementi di fissaggio. Se necessario, provvedere al giusto serraggio delle viti e dei dadi. Con "intervalli regolari" si intende all'inizio della messa in opera e due volte al mese durante l'uso regolare dell'attrezzo ludico. Verificare ogni anno le condizioni dello strato di vernice protettiva. Per una durata ottimale dell'attrezzo, è necessario provvedere una volta ogni 2 anni alla verniciatura della AXI Amy. Utilizzare a tale scopo una vernice a base di acqua / un colorante in soluzione acquosa a base naturale.

AMY SANDBOX WITH STORAGE



GUARANTEE

GUARANTEE

Congratulations on your purchase of the AXI Amy Sandbox. You have bought a product you will enjoy for many years. AXI provides a 2-year guarantee on this product - when properly used - in respect of the joints and accessories and a guarantee of five years on the wood according to the general guarantee terms & conditions. If the product does not reach you in good condition or if there are other problems, please contact your dealer or point of sale where you purchased the product.

GARANTIE

Herzlichen Glückwunsch zum Erwerb der AXI Amy Sandbox. Mit Ihrer Entscheidung haben Sie ein Produkt erworben, an dem Sie viele Jahre lang Freude haben werden. AXI gibt entsprechend den allgemeinen Garantieb Bestimmungen für das Produkt - bei richtiger Verwendung - eine Garantie von 2 Jahren auf die Verbindungen und das Zubehör sowie eine Garantie von 5 Jahren auf das Holz. Wenn Sie das Produkt nicht in einwandfreiem Zustand erhalten oder wenn sich andere Probleme ergeben, wenden Sie sich dann an den Händler oder die Verkaufsstelle, wo Sie das Produkt erworben haben.

GARANTIE

Gefeliciteerd met uw aankoop van de AXI Amy Sandbox. Met deze keuze heeft u een product gekocht waarvan u jarenlang plezier zult hebben. AXI verstrekt op dit product - bij juist gebruik - een garantie van 2 jaar op de verbindingen en accessoires en een garantie van 5 jaar op het hout volgens de algemene garantievooraarden. Mocht het product u niet in goede staat bereiken of als er zich andere problemen voordoen, neem dan contact op met uw dealer of verkooppunt waar u het product heeft aangeschaft.

GARANTIE

Félicitations pour votre achat du AXI Amy Sandbox. Vous avez choisi un produit qui vous apportera du bonheur pendant des années. Sur le produit, AXI offre une garantie de 2 ans pour les raccords et accessoires ainsi qu'une garantie de 5 sur le bois, à condition de l'utiliser de manière adéquate et conformément aux conditions générales de la garantie. Veuillez contacter votre revendeur ou le point de vente où vous l'avez acheté si le produit n'est pas livré en bon état ou si vous constatez un autre problème.

LA GARANTIA

Felicidades por la compra del AXI Amy Sandbox. Al elegir nuestra marca, usted disfrutará muchos años de un producto de calidad. AXI ofrece una garantía de 2 años a las conexiones y accesorios el producto, siempre que se utilicen de forma adecuada, y una garantía de 5 años a la madera de acuerdo con las condiciones de garantía generales. Si el producto no cumple con las especificaciones en el momento de la entrega o en caso de otros problemas, contáctese con el distribuidor o el punto de venta donde se realizó la compra.

GARANZIA

Congratulazioni per l'acquisto della AXI Amy Sandbox. Con l'acquisto dei nostri prodotti avete scelto una qualità che dura nel tempo. Il prodotto - fermo restando un idoneo utilizzo - da una garanzia AXI di 2 anni sui giunti e sugli accessori e di 5 anni sui materiali lignei, secondo quanto previsto dalle condizioni generali di garanzia. Qualora il prodotto non risulti conforme alle specifiche all'atto della consegna o in caso di altri inconvenienti, contattare il rivenditore o il punto vendita presso cui è avvenuto l'acquisto.



WARNING!

Manufacturer and seller expressly disclaim any and all liability for personal injury, property damage or loss, either direct, indirect or incidental, resulting from the incorrect attachment, improper use, inadequate maintenance, or neglect of this product.



Have Fun!

Pragma
the multi-brand company

A Pragma Brand

AXI is one of our brands with awesome products of great quality, that offers hours of active fun!

Pragma / AXI

Kruisboog 40
3905 TG Veenendaal
Netherlands
T: +31 (0)318 - 57 88 00
info@pragma-trading.com
www.pragma-trading.com

Article number / Artikelnummer / Artikelnummer /
Numéro d'article / Número de artículo / Codice articolo

A031.005.00

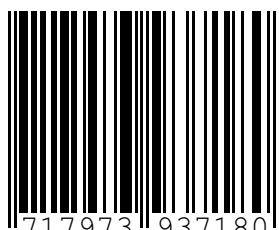

8 717973 937180

181212JW