

QUALITY:

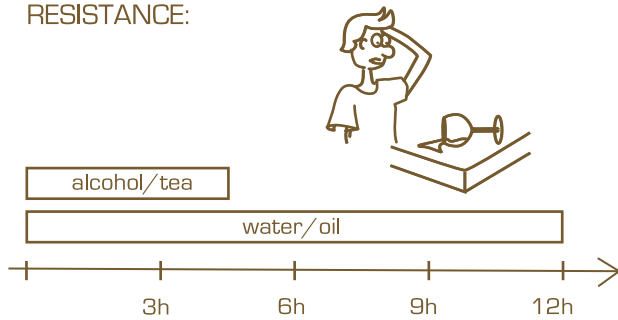

RESISTANCE:



RESPONSIBILITY:



INFO:



+41 41 780 38 08



service@phoenix-group.ch



www.phoenix-home.info



www.phoenix-home.info

PH04 010-16



PRINCESS

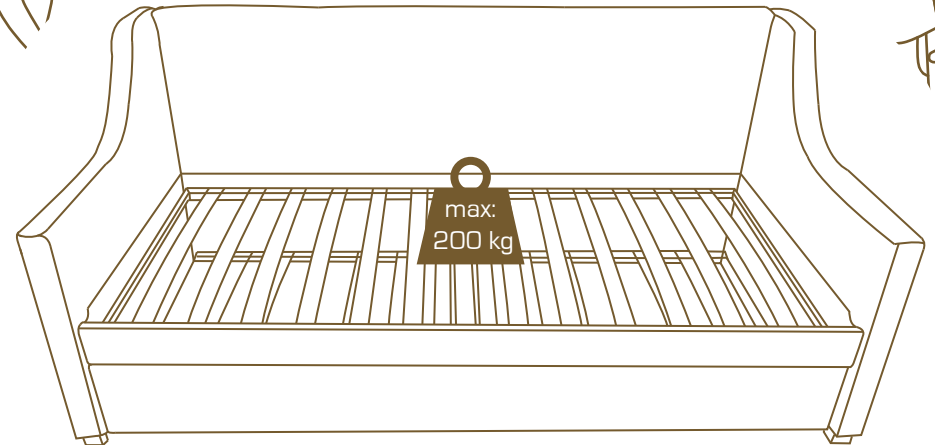
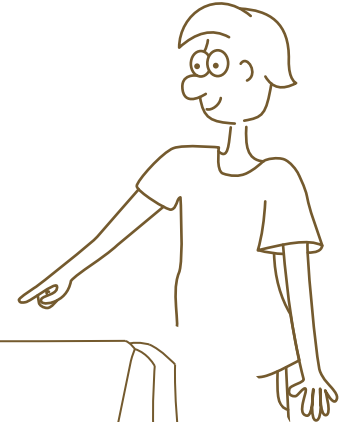
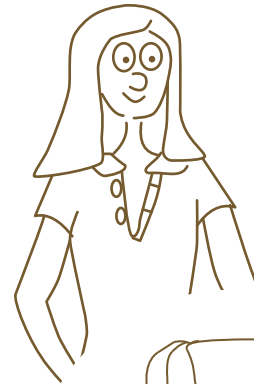

ITM: 417210

SIZE: 110x96,5x210 CM
(200x96,5x210 CM)

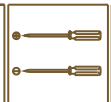

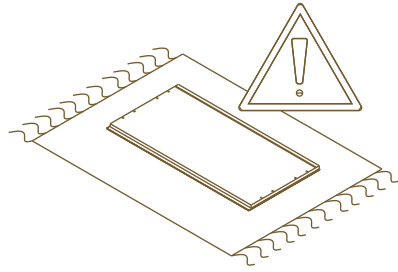
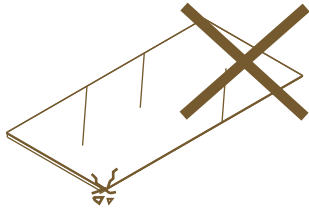

A 1x



B 1x



C 1x



D 1x



E 1x



F 1x

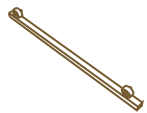

G 2x



H 25x

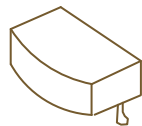

I 50x



J 4x



K 1x



L 16x

M 8



M 28x

M 8



N 8x

M 8



O 4x

M 8



P 1x

M 8



Q 4x

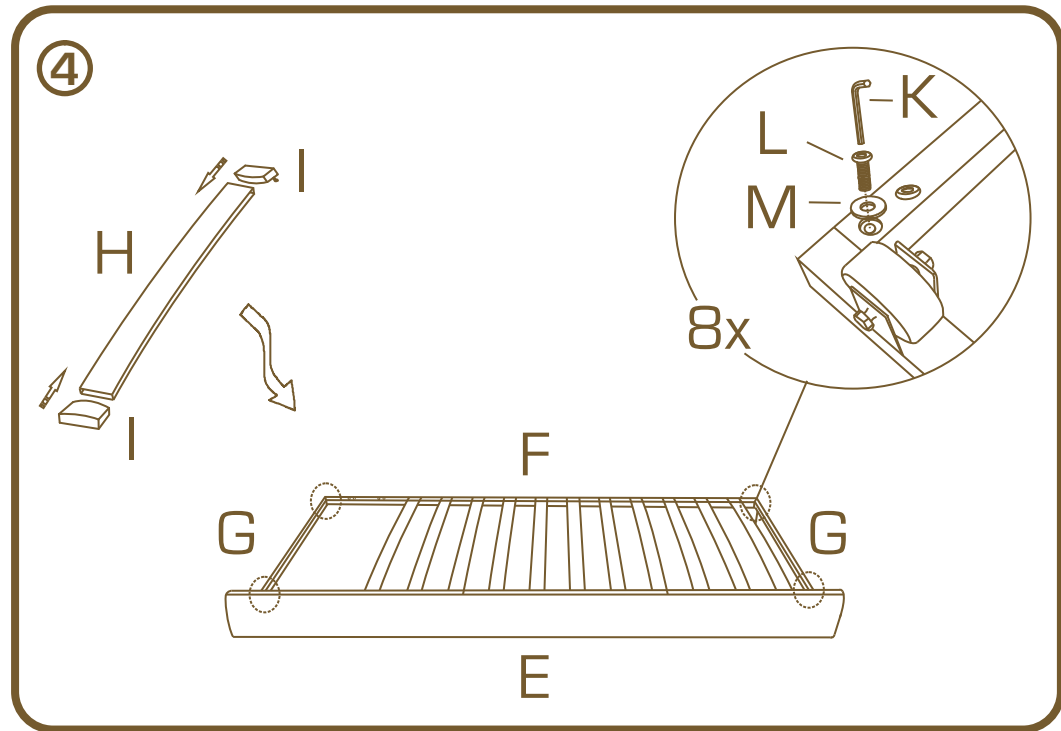
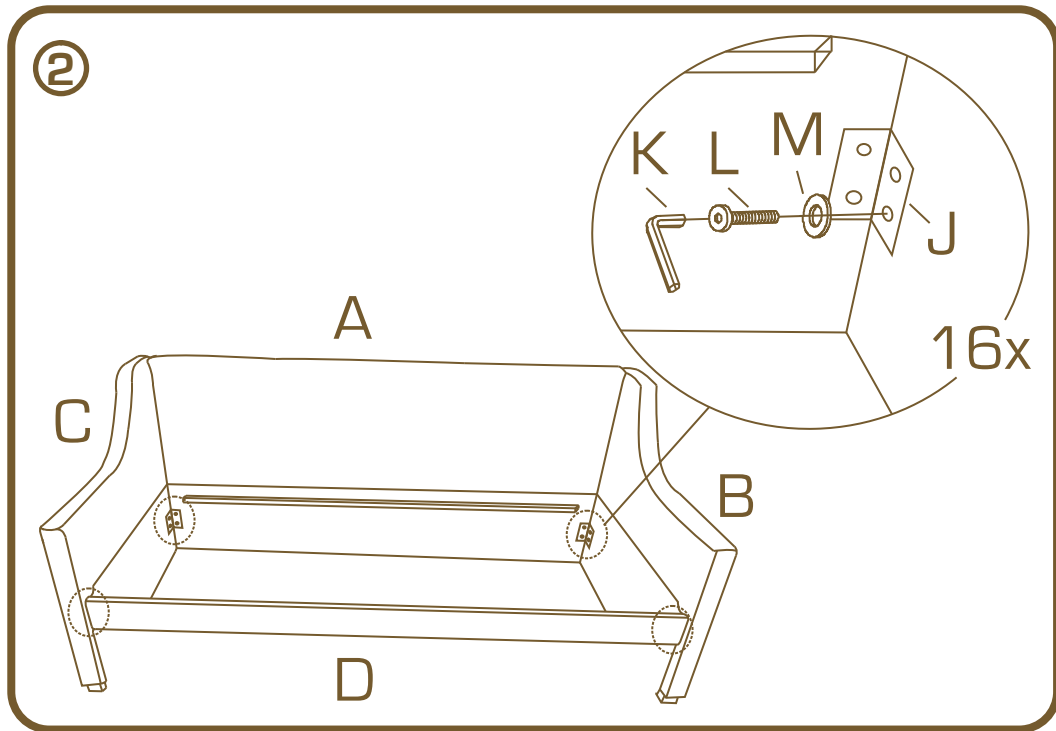
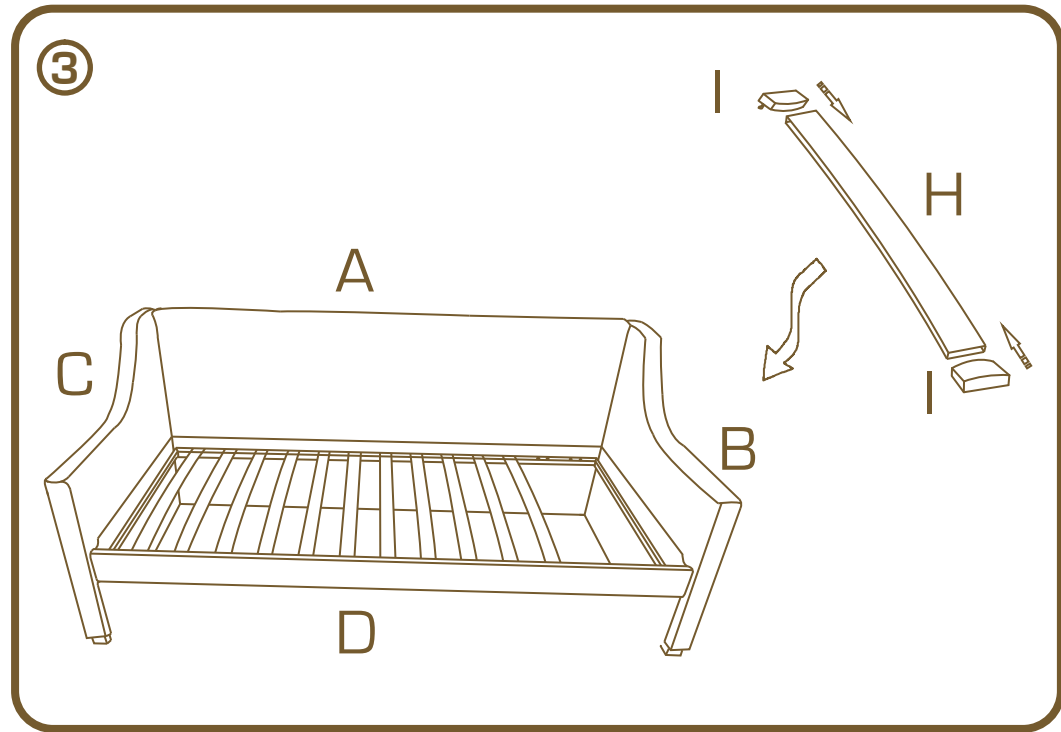
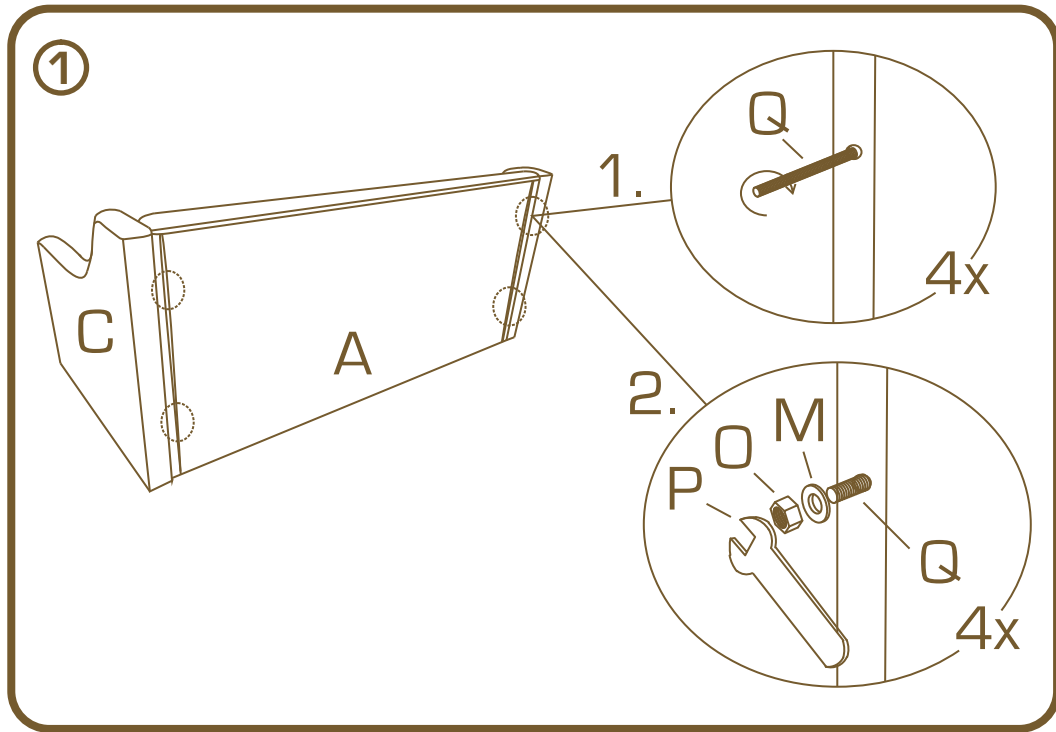

⑤

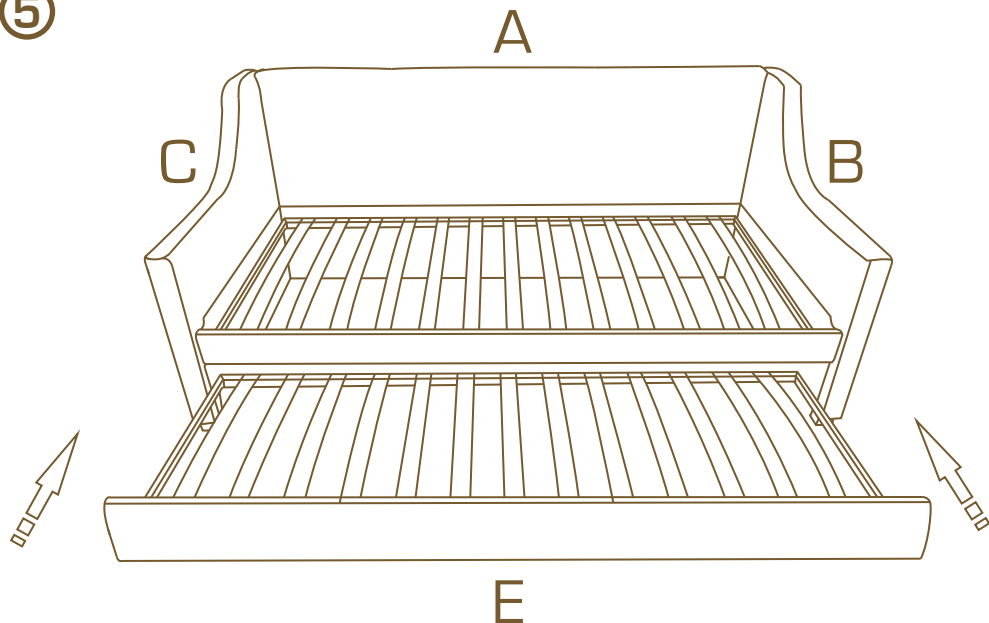

⑥

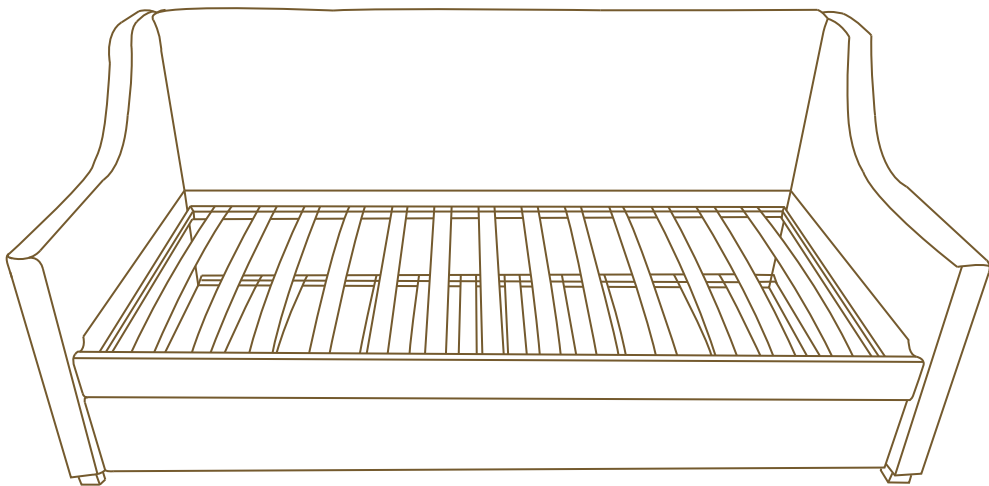

Sicherheitshinweise / Security advices

GB

Please take the time to carefully read through the whole of these instructions before you commence. Keep these instructions for future reference. Unpack, inspect and check off all of the contents. Please dispose of all packaging safely.

Small component parts could choke a child if swallowed. We strongly recommend that you keep children well away from the work area.

It would be sensible to lay a sheet or blanket on the floor where you intend to work to avoid scratching this product and to protect your floor.

This product is heavy. Take extreme care when lifting to avoid personal injury or damage to the product.

Assemble the product as close to its intended final position in the room as possible.

General Care

Wipe clean with a slightly damp soft cloth.

Avoid the use of all household cleaners and abrasives. When moving your furniture, carefully lift into place. Never drag or push the pieces across the floor as this will cause damage to the joints and could result in failure to the product that will invalidate the warranty.

Recommendations

Periodical re-tightening of fixings.

Warning

This unit is heavy. Please use an assistant when lifting.

DE

Bitte nehmen Sie sich die Zeit, diese Anweisungen sorgfältig durchzulesen, bevor Sie beginnen. Bewahren Sie diese Anweisungen zum späteren Nachschlagen auf. Den gesamten Inhalt auspacken, prüfen und abhaken. Bitte entsorgen Sie alle Verpackungen sicher. Kleinteile könnten ein Kind ersticken, wenn sie verschluckt werden. Wir empfehlen dringend, Kinder vom Arbeitsbereich fernzuhalten.

Es wäre sinnvoll, ein Laken oder eine Decke auf den Boden zu legen, auf dem Sie arbeiten möchten, um ein Verkratzen dieses Produkts zu vermeiden und Ihren Boden zu schützen.

Dieses Produkt ist schwer. Gehen Sie beim Anheben äußerst vorsichtig vor, um Verletzungen oder Schäden am Produkt zu vermeiden.

Montieren Sie das Produkt so nah wie möglich an seiner beabsichtigten endgültigen Position im Raum.

Allgemeine Pflege

Mit einem leicht angefeuchteten, weichen Tuch abwischen.

Vermeiden Sie die Verwendung aller Haushaltsreiniger und Scheuermittel. Wenn Sie Ihre Möbel bewegen, heben Sie sie vorsichtig an ihren Platz. Ziehen oder schieben Sie die Teile niemals so über den Boden

kann Schäden an den Gelenken verursachen und zu einem Ausfall des Produkts führen, wodurch die Garantie erlischt.

Empfehlungen

Regelmäßiges Nachziehen der Befestigungen.

Warnung

Dieses Sofa ist schwer. Verwenden Sie beim Anheben bitte einen Helfer.

- DE** WICHTIG! - FÜR SPÄTERES NACHSCHLAGEN AUFBEWAHREN! SORGFÄLTIG LESEN!
- GB** ATTENTION! - PLEASE STORE FOR FURTHER ENQUIRIES! READ CAREFULLY!
- FR** IMPORTANT! - CONSERVER POUR UNE UTILISATION ULTÉRIEURE - LIRE ATTENTIVEMENT!
- ES** ¡ATENCIÓN! - GUARDAR PARA UN USO POSTERIOR. - LÉASE DETENIDAMENTE!
- PT** IMPORTANTE! - GUARDAR PARA FUTURAS CONSULTAS - LER COM ATENÇÃO!
- IT** IMPORTANTE! CONSERVARE PER L'USO FUTURO - LEGGERE CON ATTENZIONE!
- NL** BELANGRIJK! - BEWAAR DE HANDLEIDING VOOR LATERE RAADPLEGING!
ZORGVULDIG LEZEN!
- DK** VIGTIGT! BØR OPBEVARES TIL SENERE BRUG - SKAL LÆSES GRUNDIGT!
- SE** VIKTIGT! SPARAS FÖR FRAMTIDA BRUK - MÅSTE LÄSAS NOGA!
- FI** TÄRKEÄÄ! - SÄILYTÄ MYÖHEMPÄÄ KÄYTTÖÄ VARTEN - LUE TARKKAVAISESTI!
- NO** VIKTIG! - OPPBEVARES FOR SENERE BRUK - MÅ LESES NØYE!
- PL** WAŻNE! ZACHOWAĆ NA PRZYSZŁOŚĆ! STARANNIE PRZECZYTAĆ!
- CZ** DŮLEŽITÉ! - NÁVOD SI USCHŮVEJTE PRO POZDĚJŠÍ POUŽITÍ! - PEČLIVĚ SI JEJ PROČTĚTE!
- HU** FONTOS! - KÉSŐBBI FELHASZNÁLÁSRA ŐRIZZE MEG - GONDOSAN OLVASSA EL!
- HR** VAŽNO! - SAČUVATI ZA KASNIJU UPORABU - PAŽLJIVO PROČITATI!
- RO** IMPORTANT! - PĂSTRĂȚI PENTRU UTILIZARE ULTERIOARĂ - CITIȚI CU ATENȚIE!
- RS** VAŽNO! - ČUVATI ZA KASNIJU UPOTREBU - PAŽLJIVO SVE PROČITATI!
- SK** DÔLEŽITÉ! - NÁVOD UCHOVAJTE NA NESKORŠIE POUŽITIE -
DÔKLADNE SI HO PREČÍTAJTE!
- SI** POMEMBNO! - SHRANITE ZA KASNEJŠO UPORABO - TEMELJITO PREBERITE!
- TR** ÖNEMLİ!-DAHA SONRA KULLANILMAK ÜZERE DE MUHAFZA EDİNİZ-
DİKKATLE OKUYUNUZ!
- GR** ΣΗΜΑΝΤΙΚΟ! - ΝΑ ΦΥΛΑΣΣΕΤΑΙ ΓΙΑ ΑΡΓΟΤΕΡΗ ΧΡΗΣΗ - ΝΑ ΔΙΑΒΑΖΕΤΑΙ ΜΕ ΠΡΟΣΟΧΗ!
- RU** ВАЖНО: ВНИМАТЕЛЬНО ПРОЧТИТЕ И СОХРАНИТЕ!