

- | | | | |
|-----------|------------------------------------|---------------|---------------------------------|
| DE | Montageanleitung | GB USA | Assembly instructions |
| FR | Notice de montage | IT | Istruzione di montaggio |
| NL | Handleiding voor de montage | PL | Instrukcja montażu |
| CZ | Montážní návod | SK | Návod na montáž |
| HU | Szerelési útmutató | RO | Instrucțiuni de montaj |
| TR | Montaj talimatı | RU | Инструкция по монтажу |
| PT | Instruções de montagem | ES | Instrucciones de montaje |

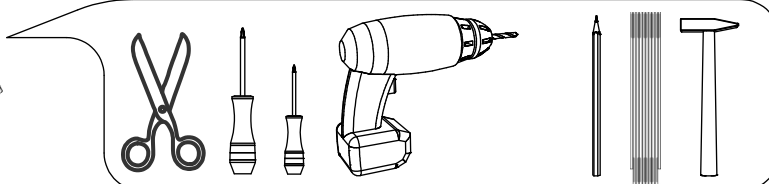

IT Avvisi di sicurezza

Durante il montaggio del mobile, il triangolo segnala i seguenti avvisi.

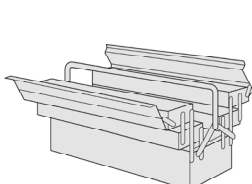
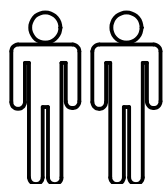

12

Tenere lontano dai bambini pezzi di ferramenta come viti, copriviti ecc. per evitare un eventuale soffocamento.

13

Seguire scrupolosamente lo schema di montaggio.

14

Prima della foratura posizionare una tavoletta sotto il pezzo per garantire un foro pulito.

17

Colorato da un lato.

DE Sicherheitshinweise

Das Dreieck erinnert Sie während der Montage an die folgenden Hinweise.



12

Achten Sie darauf, daß Kinder keine Kleinteile, wie z. B. Muttern, Abdeckkappen oder Ähnliches in den Mund nehmen. Sie könnten sie verschlucken und daran ersticken.

13

Gehen Sie bei der Montage des Artikels sorgfältig vor und halten Sie sich an die Montageanleitung.

14

Legen Sie ein Holzstück unter das zu durchbohrende Teil, um Holzaustrisse am Bohrloch zu vermeiden.

17

Eine Seite farbig.

UK USA Safety instructions

The triangle reminds you during the installation of the following notes.



12

Ensure that children do not put any small parts such as nuts, caps or the like in their mouth. They could swallow and choke on them.

13

When assembling the product, please proceed with caution and comply with the assembly instructions.

14

Before drilling place a slab under the piece to ensure a clean hole.

17

Colored on one side.

RU Правила техники безопасности

Во время монтажа треугольник служит напоминанием для следующих указаний.



12

Следите, чтобы мелкие детали, например гайки, крышки и т. п., не попали в рот ребенка. Дети могут их проглотить и задохнуться.

13

При монтаже изделия будьте внимательны и соблюдайте инструкции по монтажу.

14

Положите брусок под деталь, в которой следует сделать отверстие, чтобы избежать разрывистой поверхности вокруг отверстия

17

цветные на одной стороне

CZ Bezpečnostní pokyny

Trojúhelník vám během montáže připomene následující pokyny.



12

Dbejte na to, aby děti nedávaly do úst žádné drobné díly jako např. matice, krytky a podobně. Mohly by je spolknout a udusit se.

13

Při montáži výrobku postupujte pečlivě a dodržujte pokyny uvedené v montážním návodu.

14

Vložte kus dřeva pod části, kde vrtáte, aby se zabránilo trhlinám ve dřevě v místě vrtání.

17

obarveny na jedné straně

FR Avis de sécurité

Ces avis vous seront rappelés durant le montage par ce triangle.



12

Tenir éloignés les enfants pour éviter qu'ils ne mettent pas de petites pièces dans leur bouche, ils pourraient les avaler et étouffer.

13

Durant le montage de votre meuble veuillez procéder avec prudence et respecter les instructions de montage.

14

Pour percer sans endommager les surfaces utilisez une contre partie en bois que vous placez sous la pièces à percer.

17

Une couleur sur un face.

TR Güvenlik uyarıları

Durante a montagem do móvel, o triângulo indica as seguintes advertências.



12

Çocukların somun, muhafaza kapakçıkları ve benzeri küçük parçaları ağızlarına almamalarına dikkat ediniz. Bunları yutabilirler ve boğulabilirler.

13

Montaj esnasında büyük bir itinayla çalışınız, ürünü dikkatlice çalışınız ve mutlaka montaj talimatına uyunuz.

14

Delikte ahşap çatlaklarını önlemek için delinecek parçanın altında bir tahta koyunuz.

17

Bir tarafta renklendirilebilir

SK Bezpečnostné pokyny

Trojuholník vám počas montáže pripomenie nasledujúce pokyny.



12

Dbajte, aby si deti nemohli dať do úst drobné diely, ako napr. matice, krytky alebo podobne. Mohli by ich prehltnúť a zadusíť sa.

13

Pri montáži výrobku postupujte obozretne a dodržujte návod na montáž.

14

Vložte kus dreva pod časti, kde vrtáte, aby sa zabránilo trhlinám v dreve v mieste vŕtania.

17

zafarbené na jednej strane

NL Veiligheidsinstructies

De driehoek herinnert u tijdens de installatie van de volgende meldingen.



12

Zorg ervoor dat kinderen geen kleine stukken, zoals moeren, afdekkapjes of dergelijke in de mond nemen. Ze kunnen ze inslikken en daardoor stikken.

13

Ga bij de montage van het artikel zorgvuldig te werk en houd u aan de handleiding voor de montage.

14

Leg een stuk hout onder het onderdeel waarin een gat moet worden geboord, zodat barsten in het hout aan het geboorde gat worden vermeden.

17

van de ene kant in kleur.

PL Wskazówki bezpieczeństwa

Trójkąt przypomina o następujących wskazówkach dotyczących montażu.



12

Należy dopilnować, aby dzieci nie bawiły się lub też brały do ust żadnych drobnych części mebla, takich jak np. nakrętki, zatyczki itp.. Mogłyby je połknąć i udusić się nimi.

13

Podczas montażu proszę postępować z należytą uwagą i zgodnie z instrukcją montażu. Artykuł może być montowany tylko przez osoby z odpowiednimi kwalifikacjami.

14

Podłożyć pod przewiercaną część kawałek drewna, aby zapobiec ewentualnym pęknięciom wokół wierzonej dziury.

17

Pokolorowane na jednej stronie

RO Instrucțiuni referitoare la siguranță

Triunghiul vă atenționează să țineți cont în timpul montajului de următoarea indicație



12

Supravegheați copiii pentru că pot să introducă în gură piesele mici, cum ar fi de exemplu piulițe, capace sau altele similare. Ei pot să le înghită și se pot asfixia.

13

Procedați cu atenție la montarea produsului și respectați instrucțiunile de montaj.

14

Introduceți o bucată de lemn dedesubtul elementului de găurit, pentru a evita fisurarea lemnului în dreptul găurii.

17

colorat pe o parte

HU Biztonságtechnikai

A háromszög a szerelés közben a következő utasításra emlékezteti.



12

Gondoskodjon arról, hogy a gyerekek ne vehessék a szájukba a kis alkatrészeket, pl. az anyákat, a fed kupakokat stb. Ezeket lenyelve megfulladhatnak.

13

A termék összeszerelésekor körültekintően járjon el, és tartsa magát a szerelési útmutatóban foglaltakhoz.

14

Fektessen egy fadarabot az átfúrandó rész alá; megelőzve, hogy a furat szélének faanyagát kitöredezzen.

17

egyik oldalán színezett

PT

Avisos de segurança

Durante a montagem do móvel, o triângulo indica as seguintes advertências.



12

Mantenha longe do alcance das crianças todo o tipo de peças pequenas como parafusos e outras, para evitar o risco de sufocamento.

13

Siga escrupulosamente o esquema de montagem.

14

Antes de la perforación colocar una tableta en la pieza para asegurar un agujero limpio.

17

De color en un lado

AR

إشعارات الأمان

من فضلك اتبع الخطوات التالية الموضحة أدناه لكيفية التركيب و الرموز لها بالمثلثات الصفراء أسفله



12

تأكد من ابعاد الأجزاء الصغيرة و المسامير و البراغي التي يمكن ابتلاعها من أيدي الأطفال

13

عند تجميع و تركيب المنتج يرجى اتباع الخطوات المنصوص عليها بدقة و حذر

14

قبل الثقب يرجى وضع لوحة تحت مكان الثقب للحصول ثقب نظيف و عدم اتلاف الأرضية

17

ملون على جانب واحد

ES

Avisos de seguridad

Durante el montaje del mueble, prestar atención al triángulo que informa sobre los siguientes avisos.



12

Mantener alejado de los niños piezas de herramientas como tornillos, ecc para evitar una eventual asfixia.

13

Seguir escrupulosamente el diagrama de montaje.

14

Antes da perfuração colocar um comprimido em peça para garantir um buraco limpo.

17

Colorido em um lado.

Service • Dienstverlening • Serwis • Servis • Сервисная служба • Servizio

Name • Naam • Nazwa • Isim • Название • Nom • Nome

Nr. • No. • Номер • Nu.

Тур • Туре • Тір • Тип • Тіро

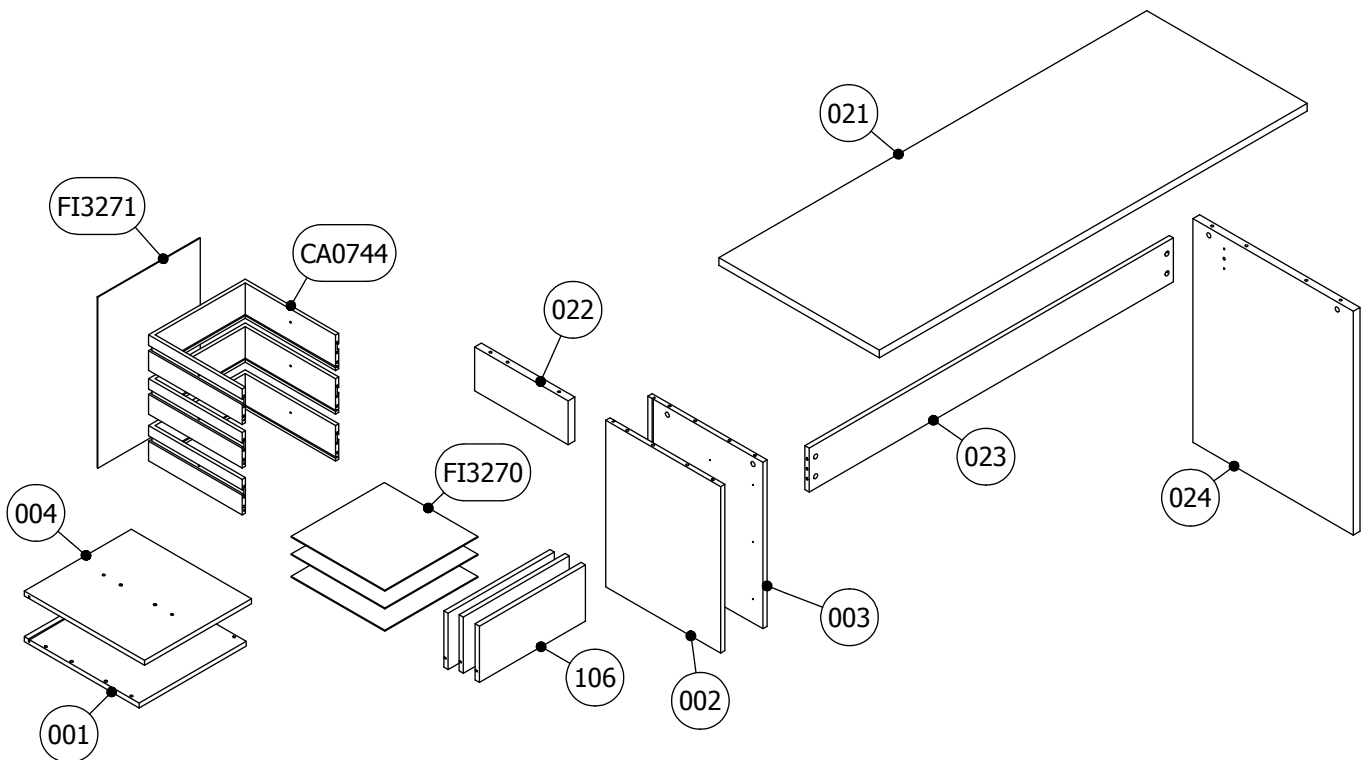
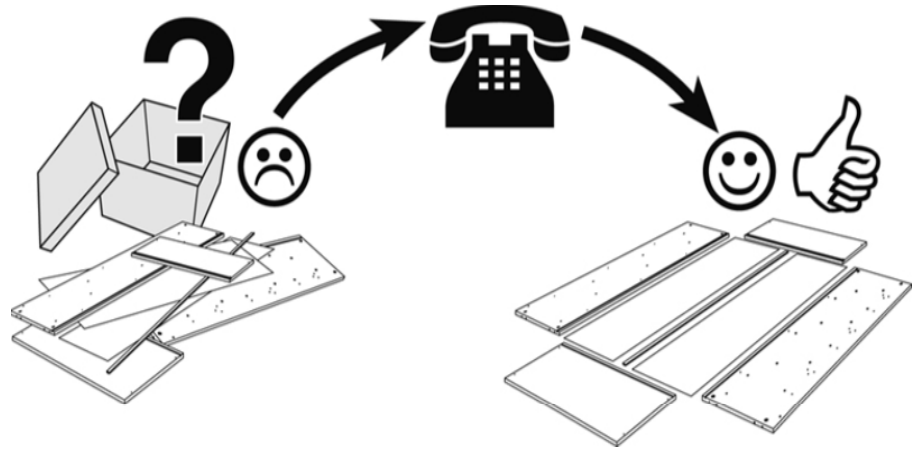

Code	Qt.	Dimensions	Box
106	3	397x182x16	2-2
001	1	400x430x16	2-2
002	1	539x430x16	2-2
003	1	539x430x16	2-2
004	1	400x450x16	2-2
021	1	1600x600x25	2-1
022	1	142x350x25	2-2
023	1	1362,5x142x16	2-1
024	1	725x600x25	2-1
CA0744	3	361x350x115	2-1
FI3270	3	348x350x3	2-2
FI3271	1	554x383x3	2-2

12

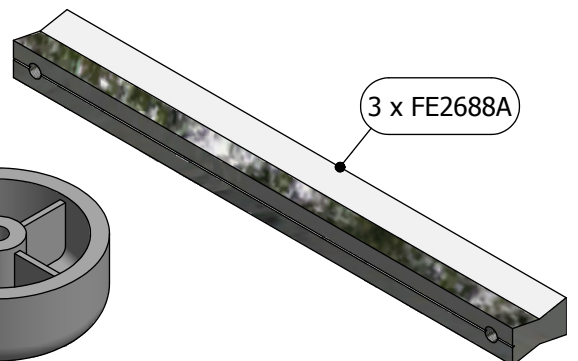
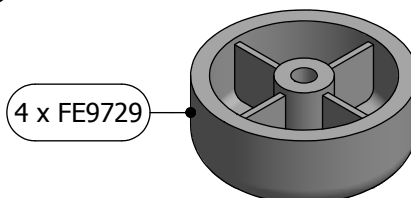
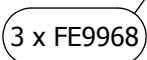
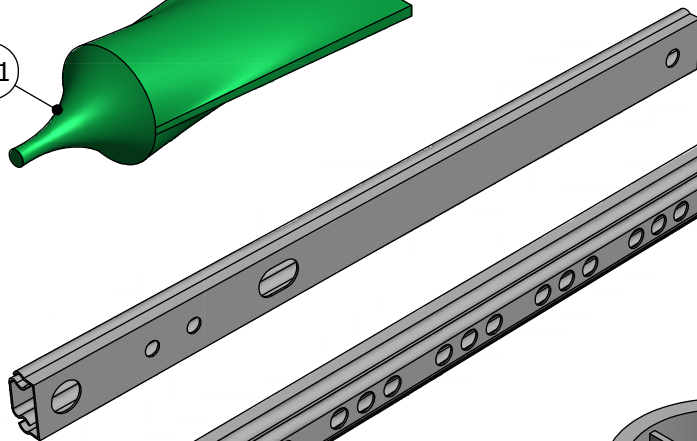
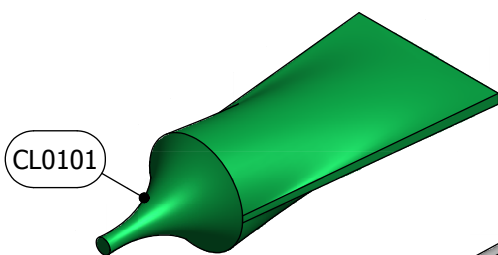
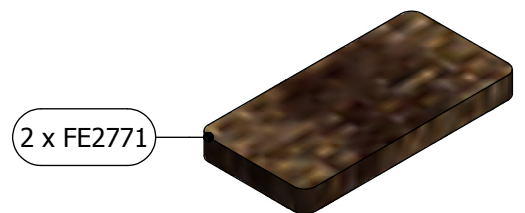
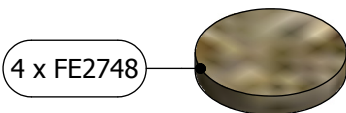
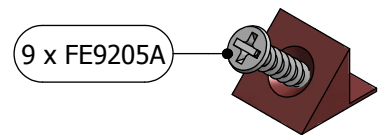
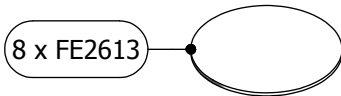
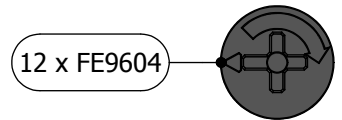
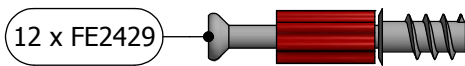
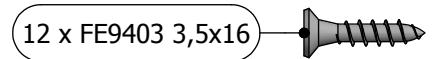
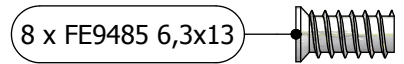
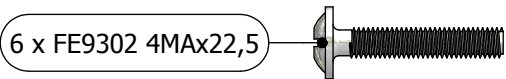
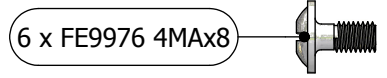
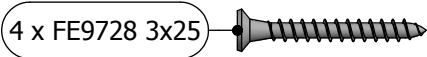
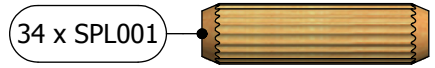
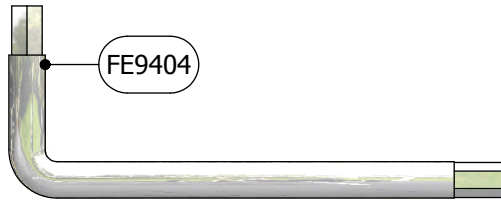

13

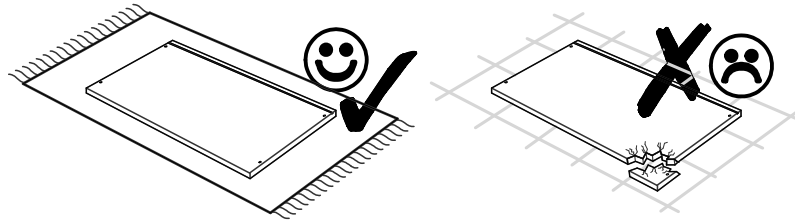

3x

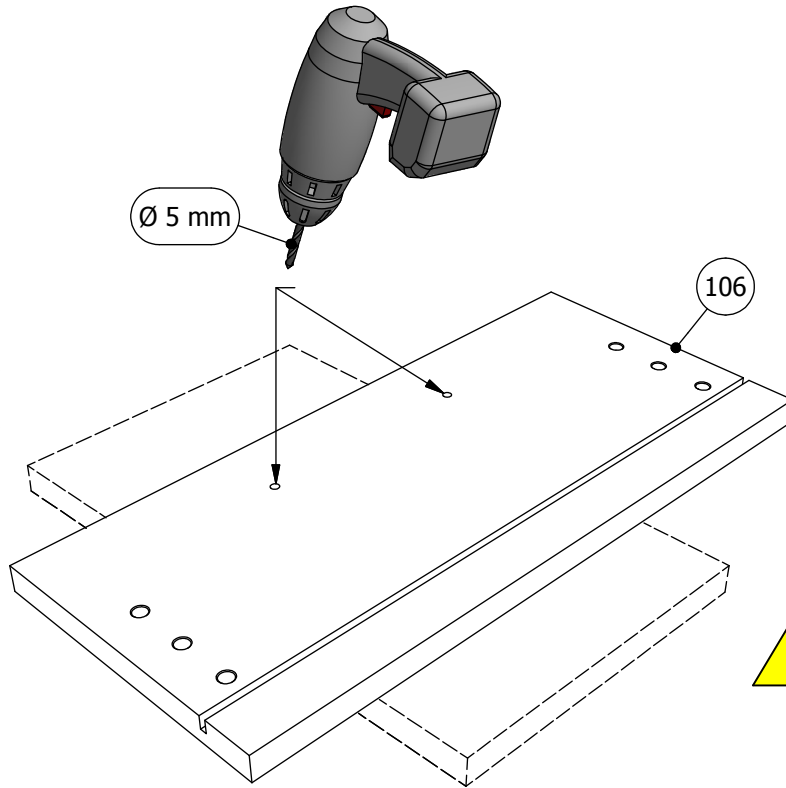

14

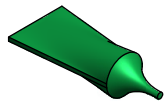

3x

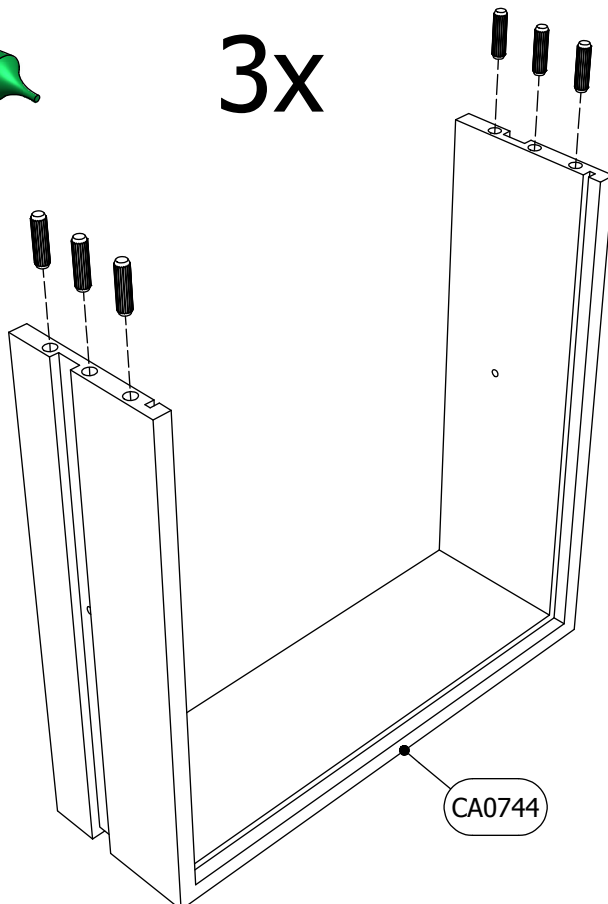

18 x SPL001

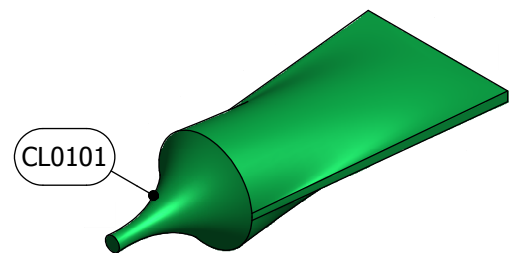

3x

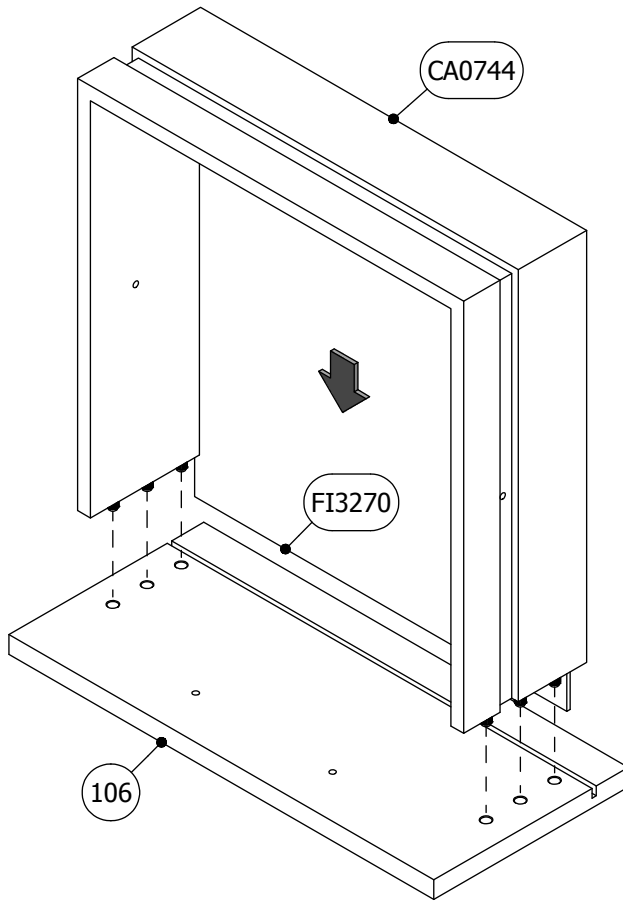
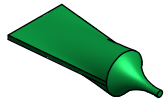

CL0101

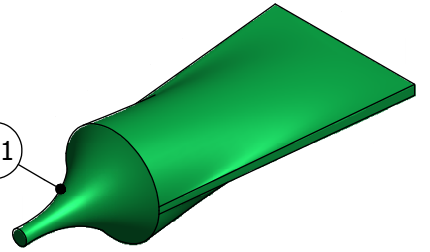

CA0744

F13270

106

3x

3 x FE9205A

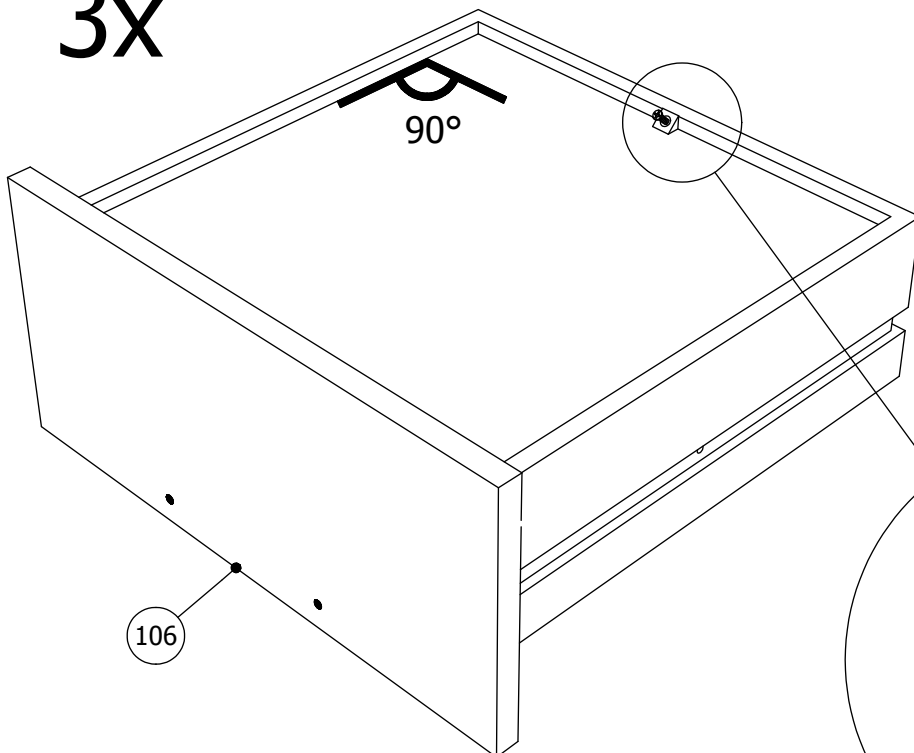
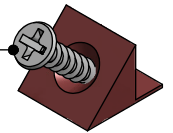

90°

106

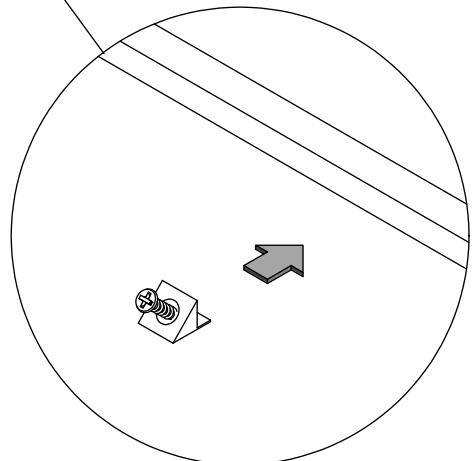

12 x FE9403 3,5x16



3 x FE9968

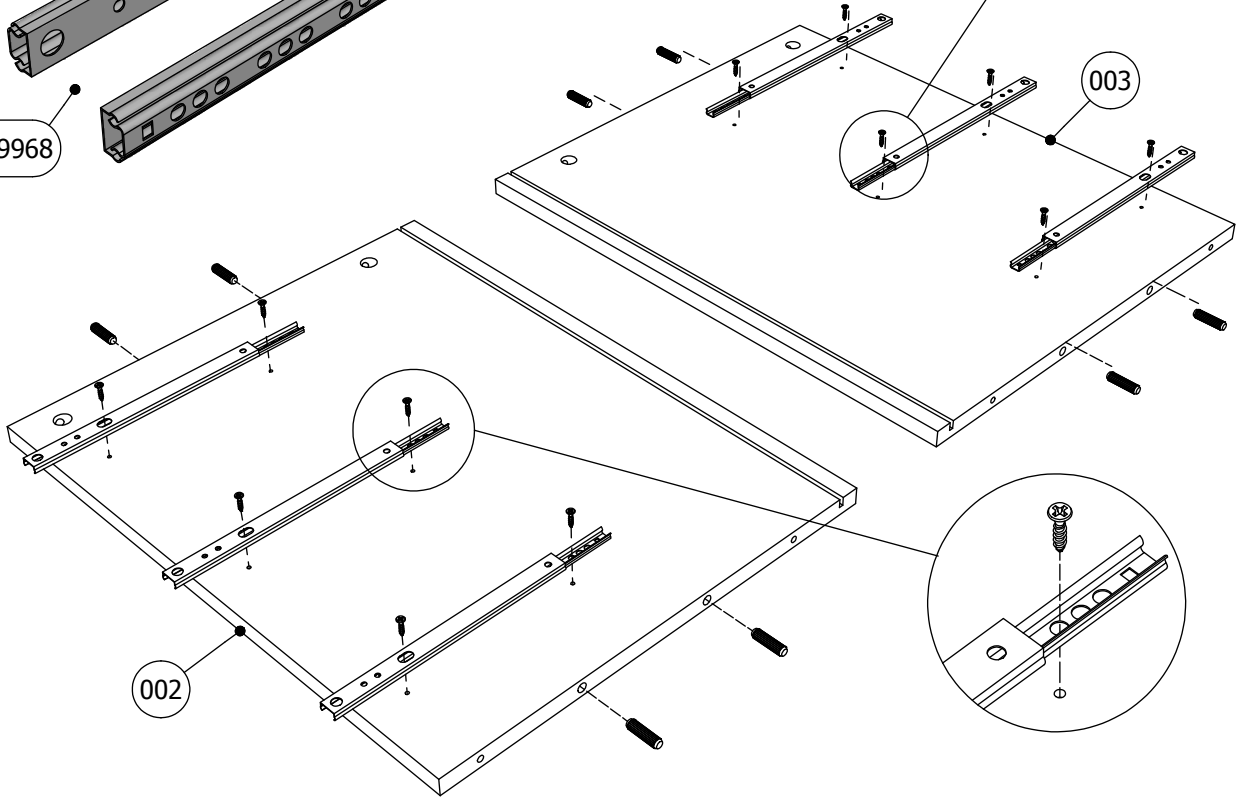
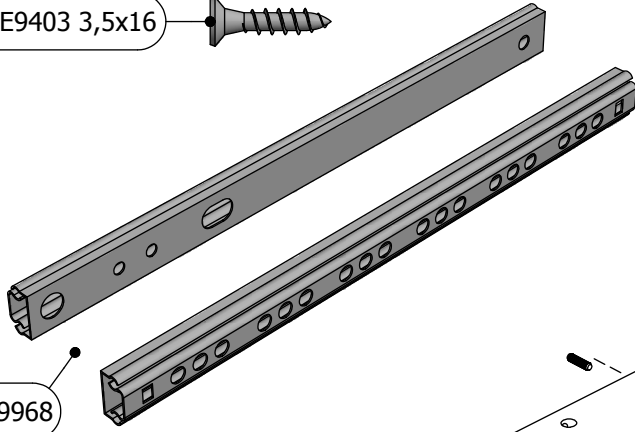

4 x FE9729

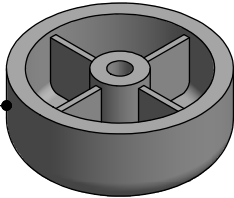

4 x FE9728 3x25



4 x FE2748

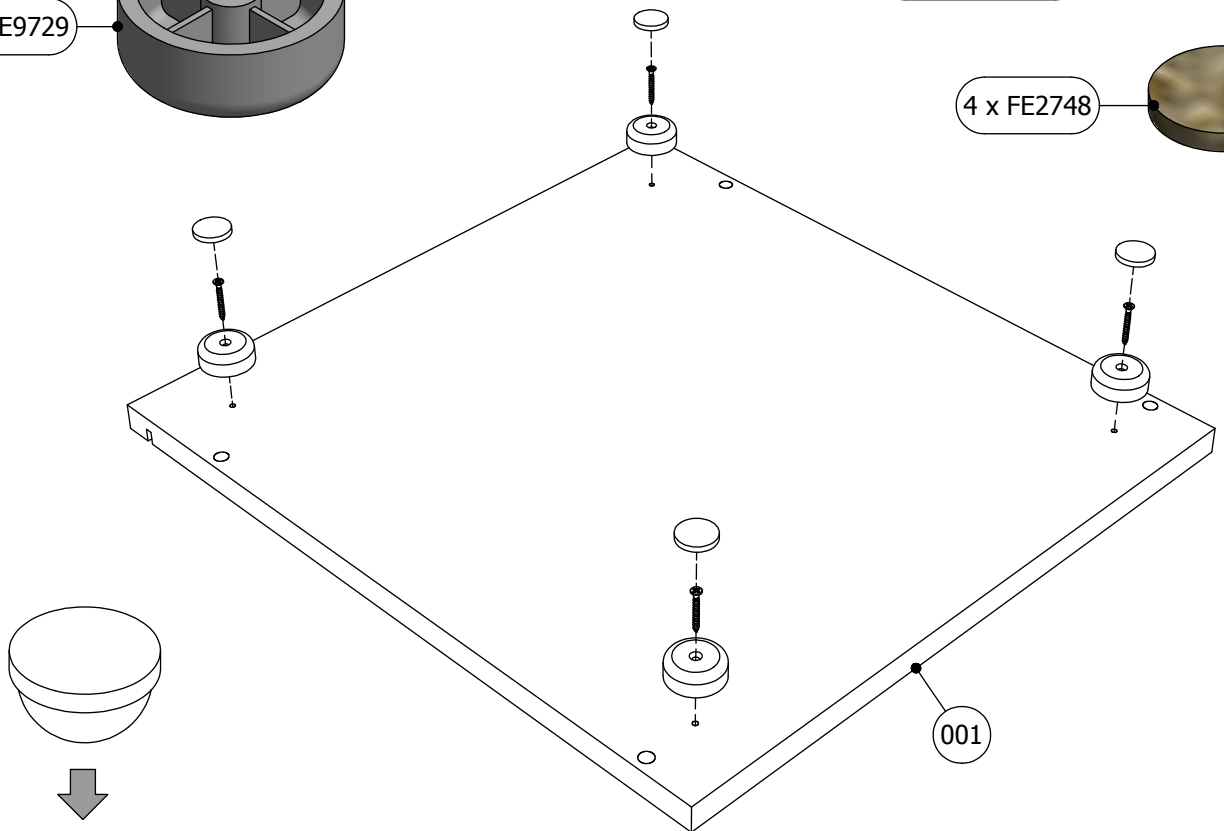

4 x FE9134 7x50

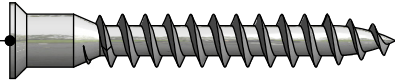

FE9404

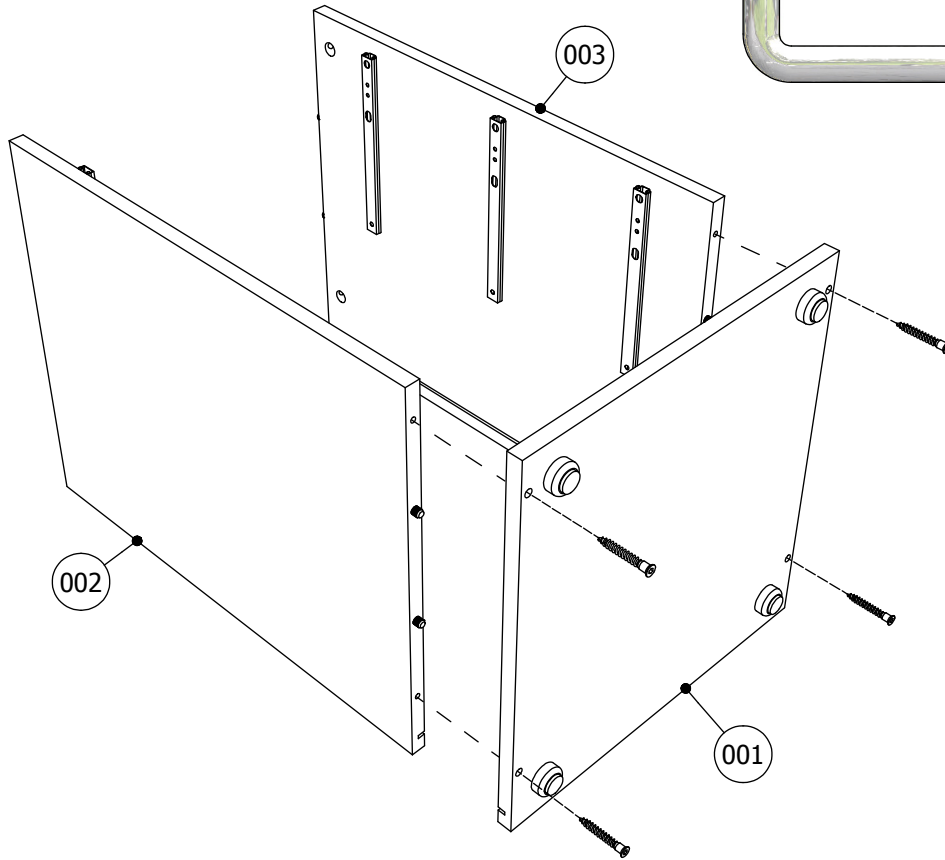
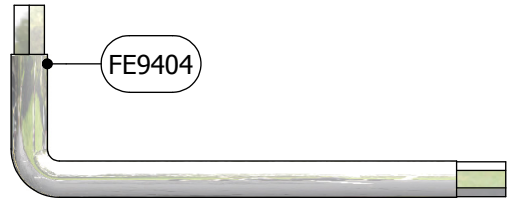

4 x FE2429

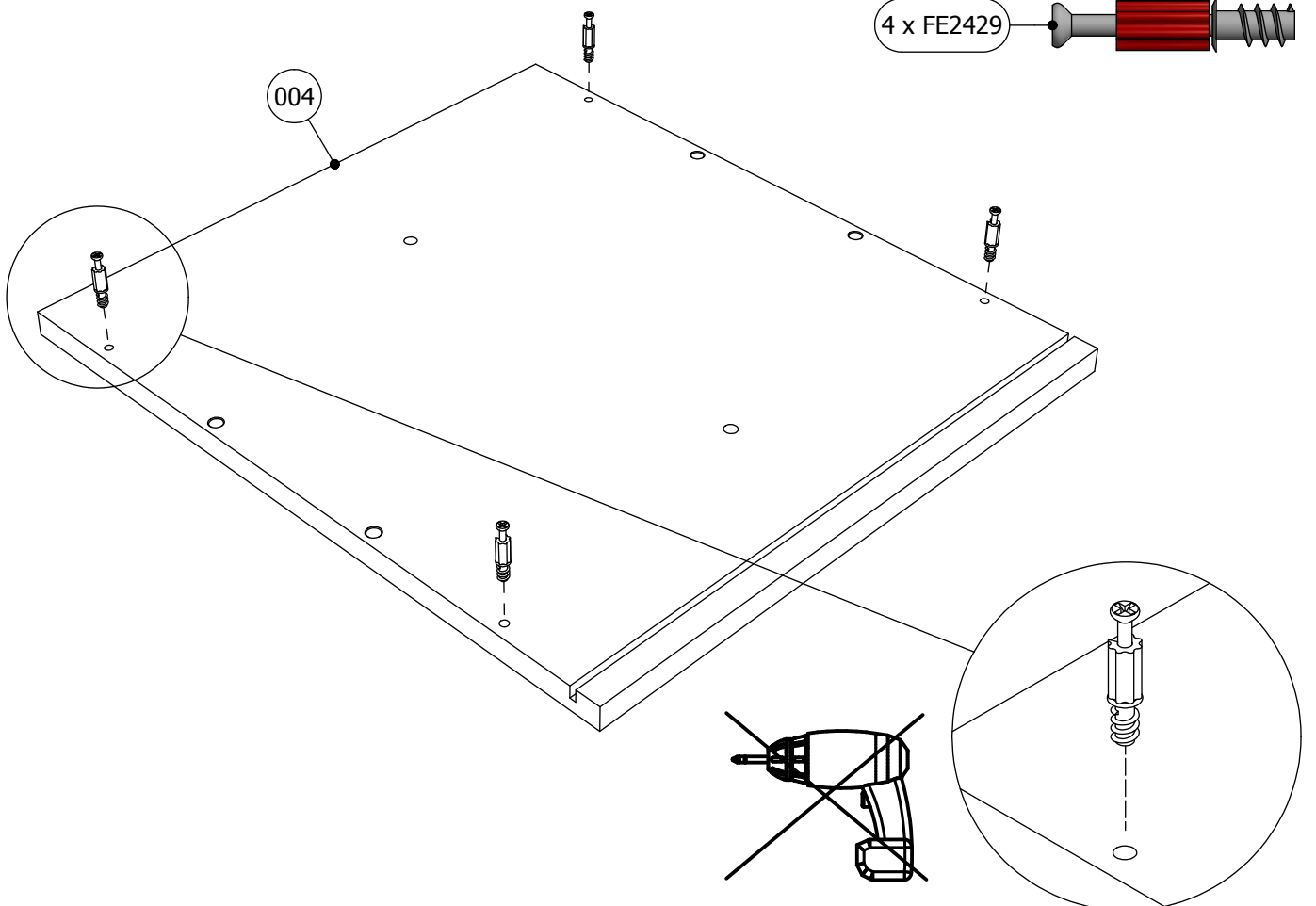

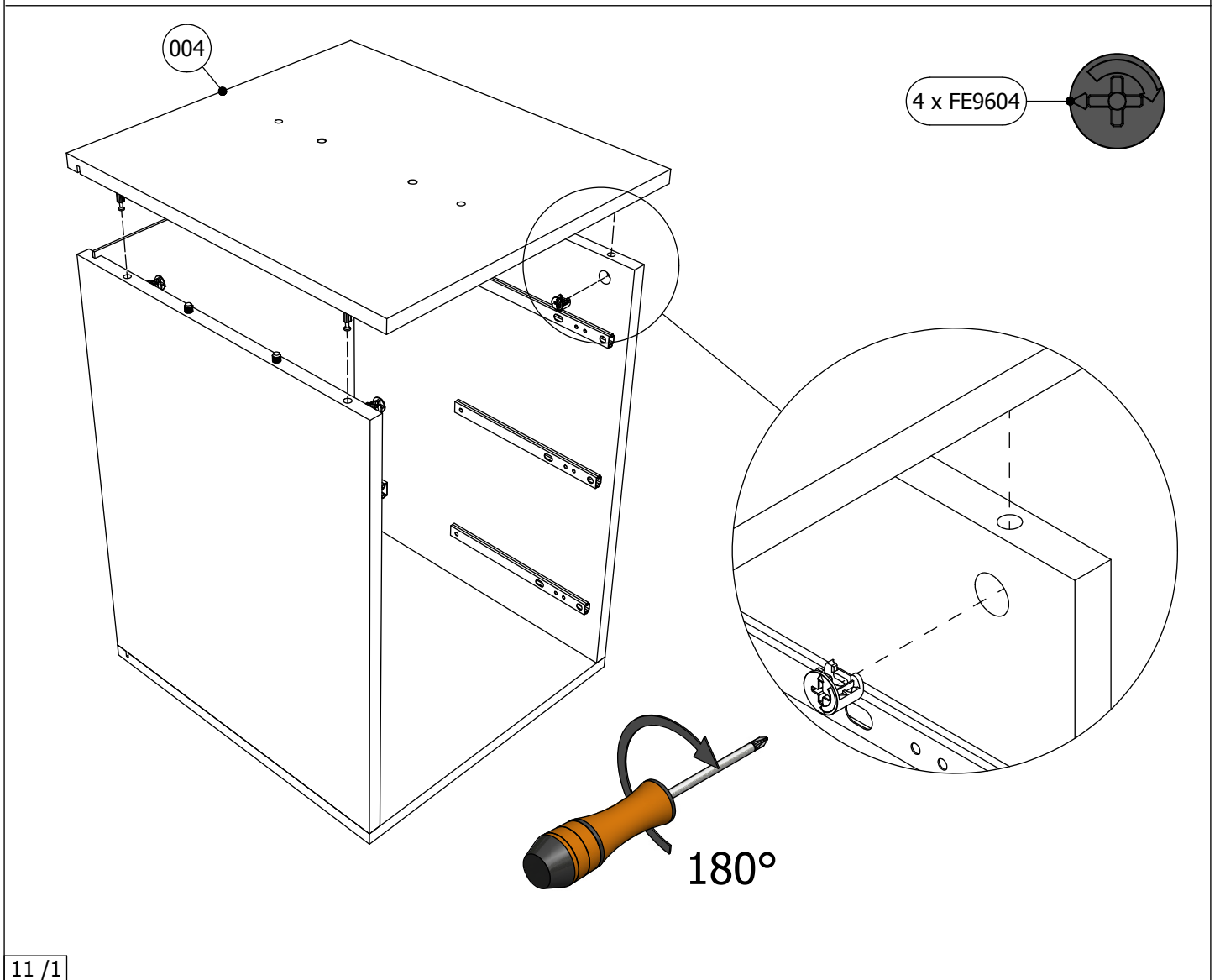
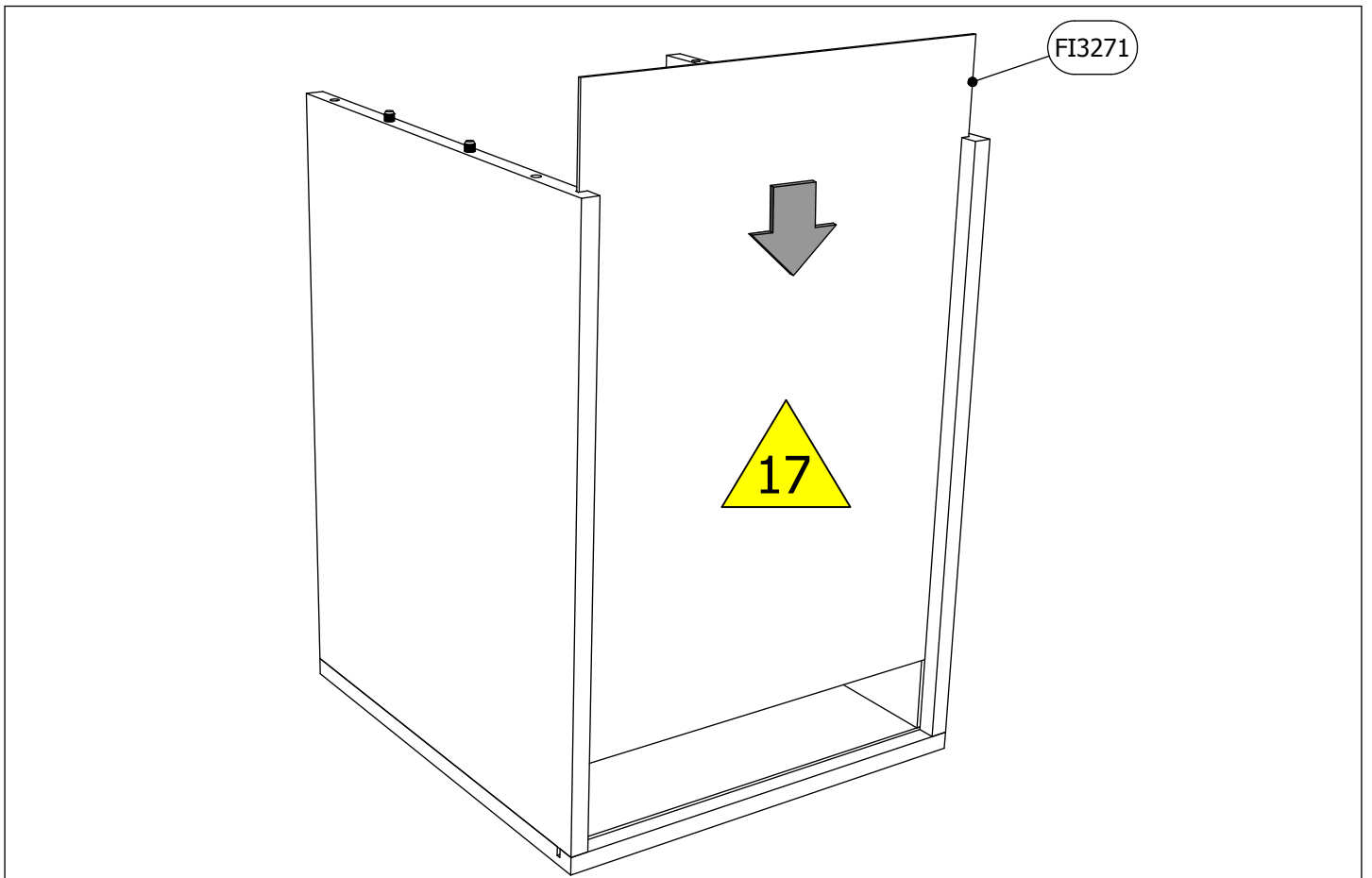

6 x FE9205A

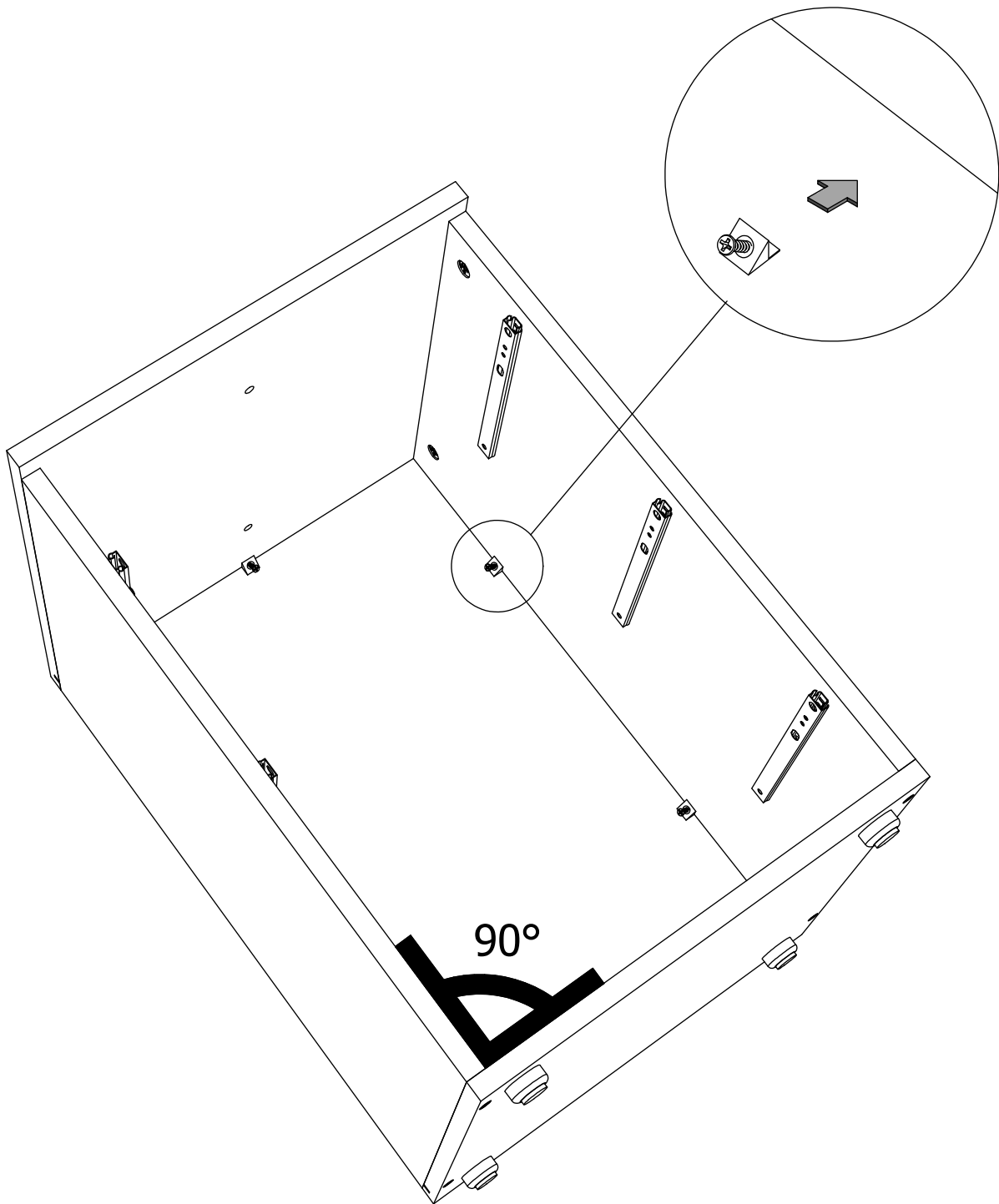
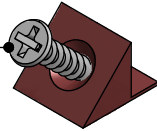

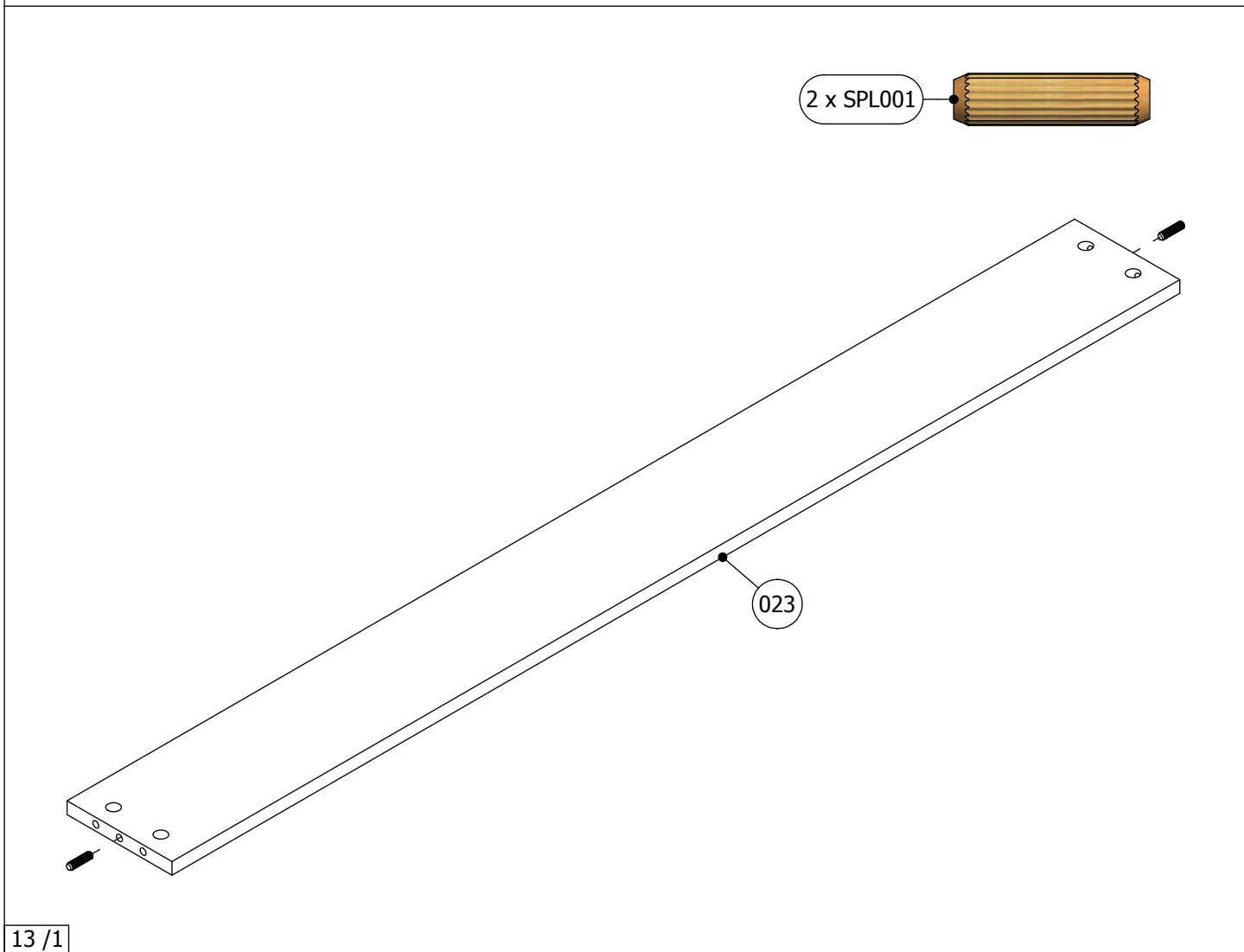
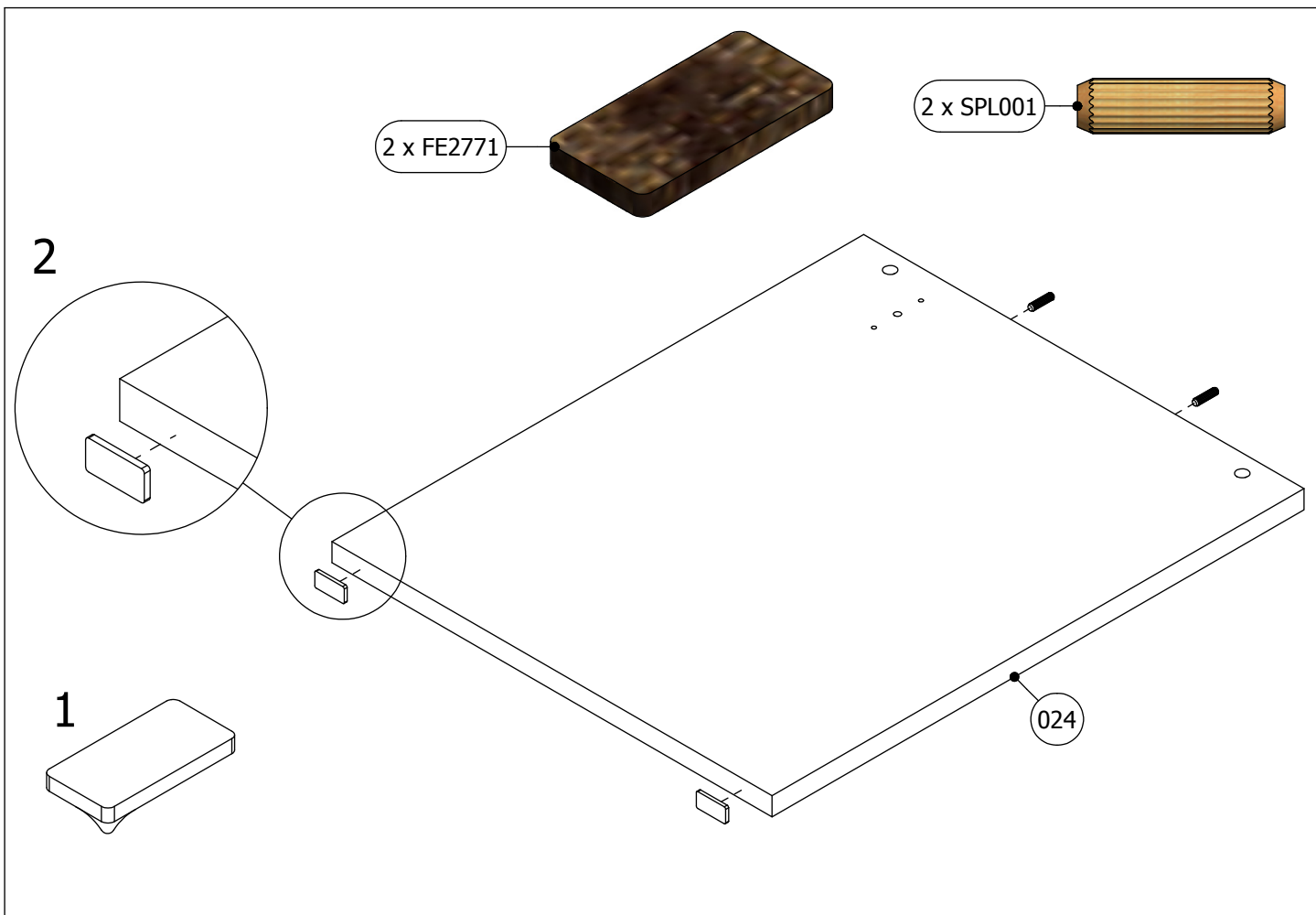

2 x FE2429



4 x SPL001

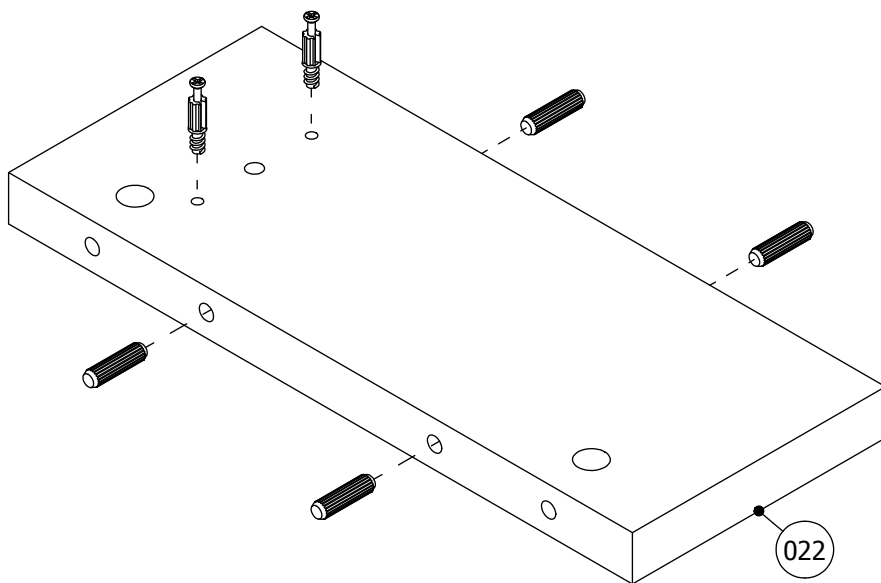

4 x FE2429

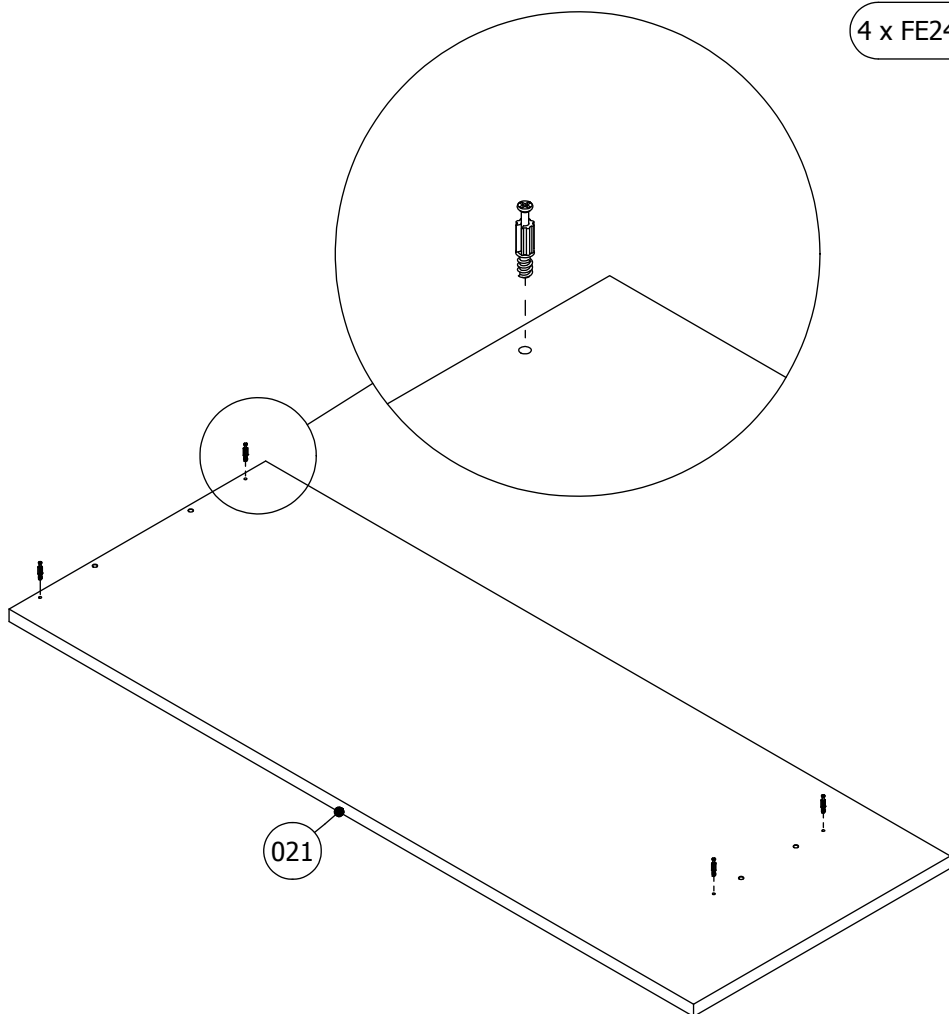

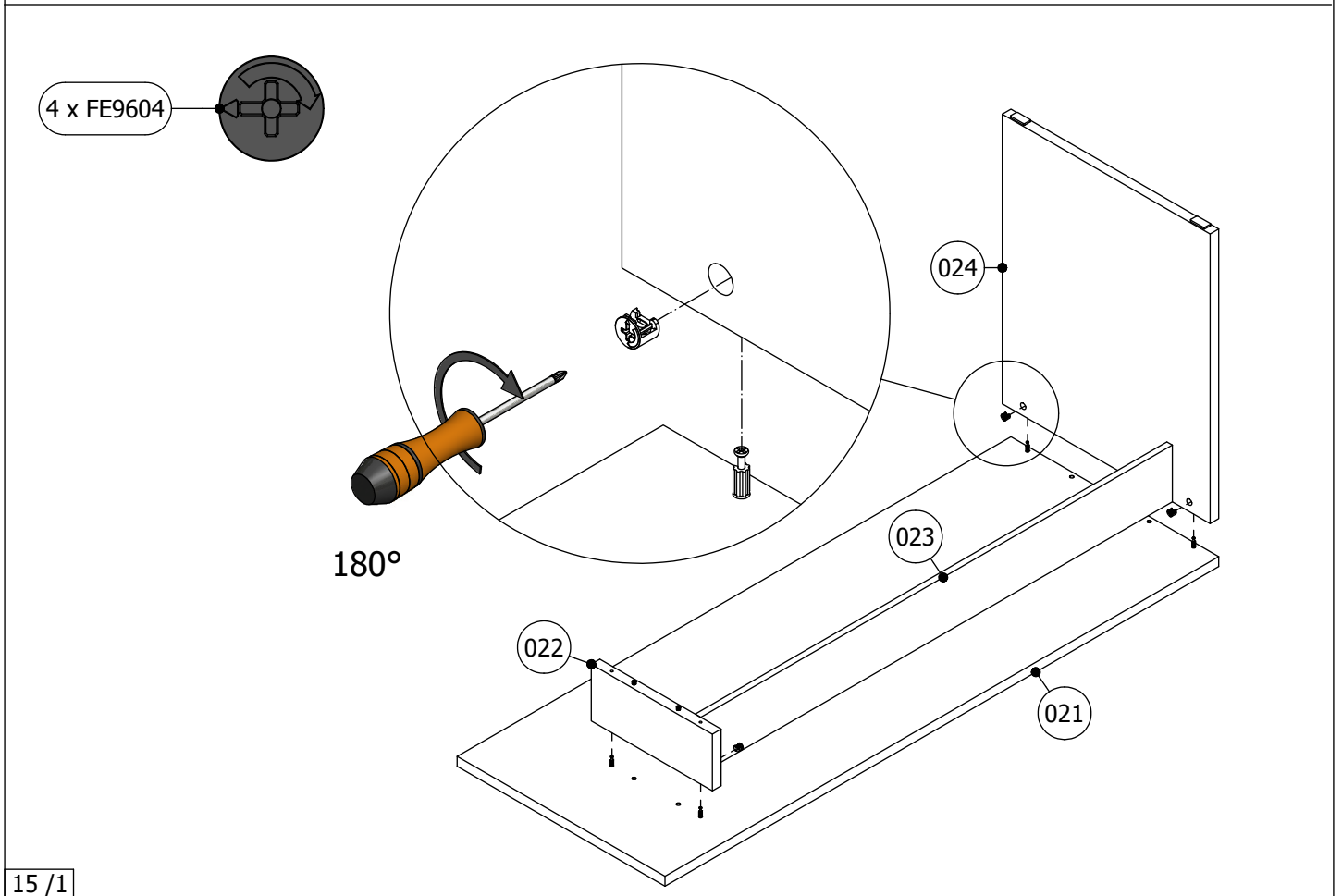
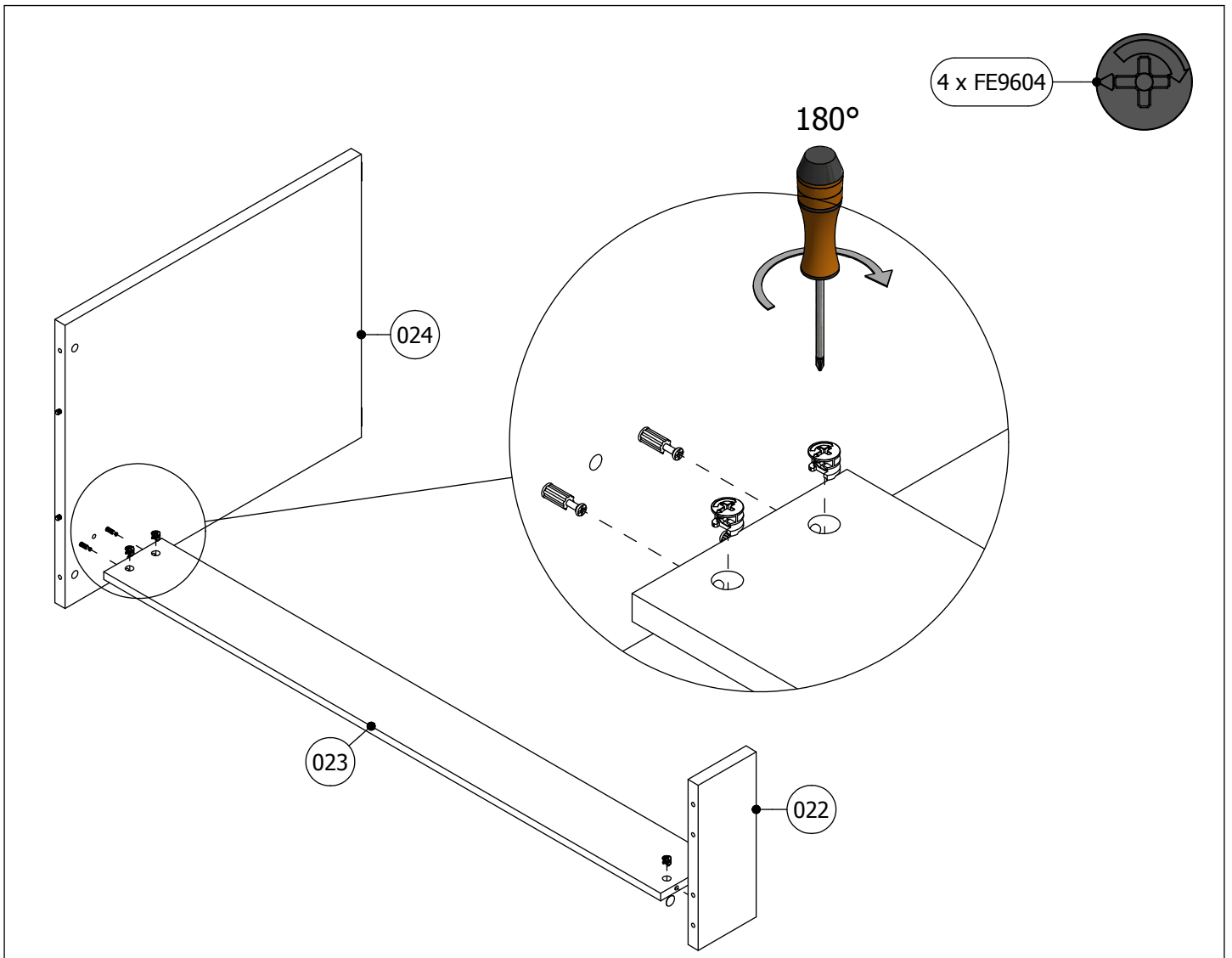

8 x FE2613

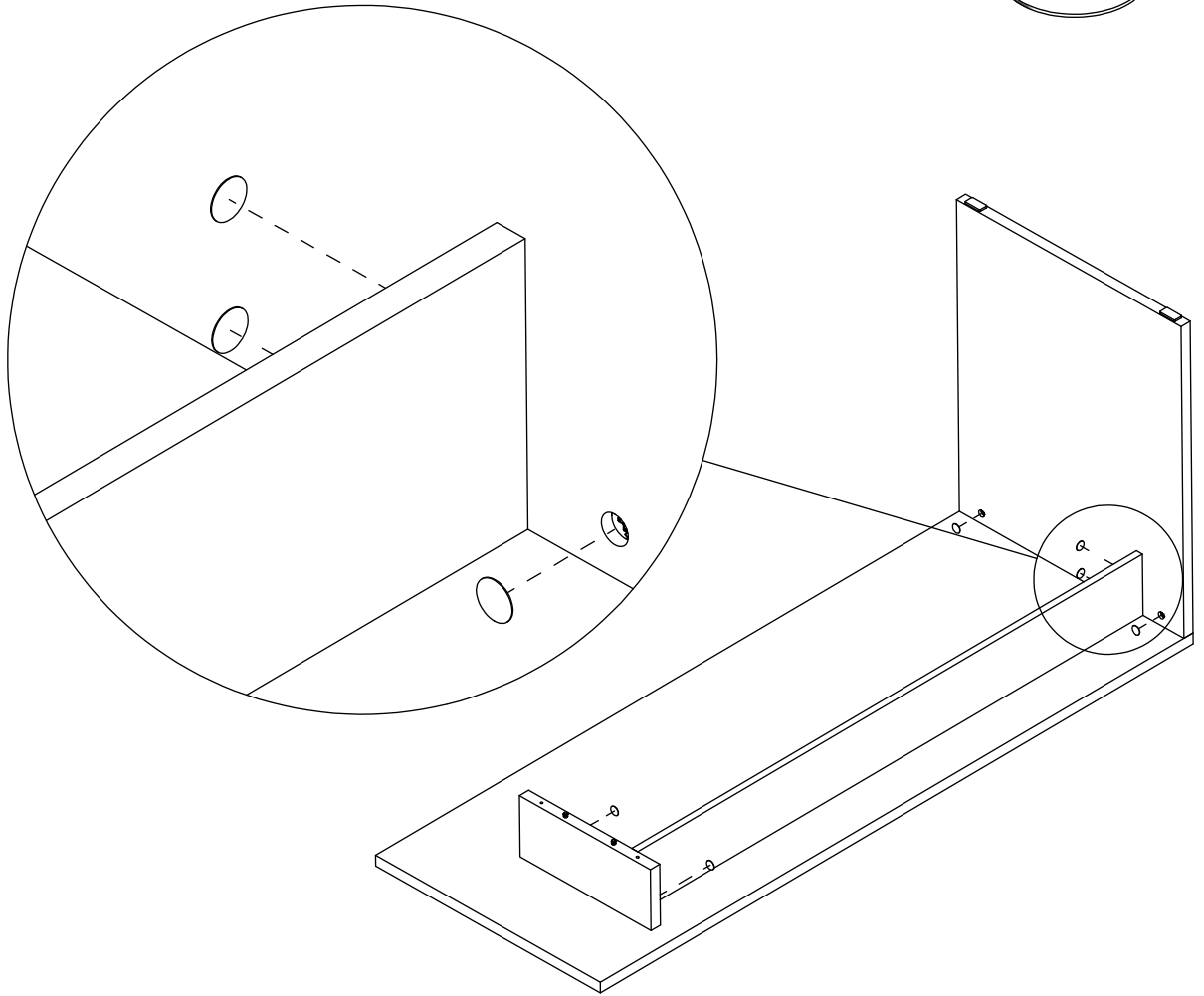

2 x FE9134 7x50

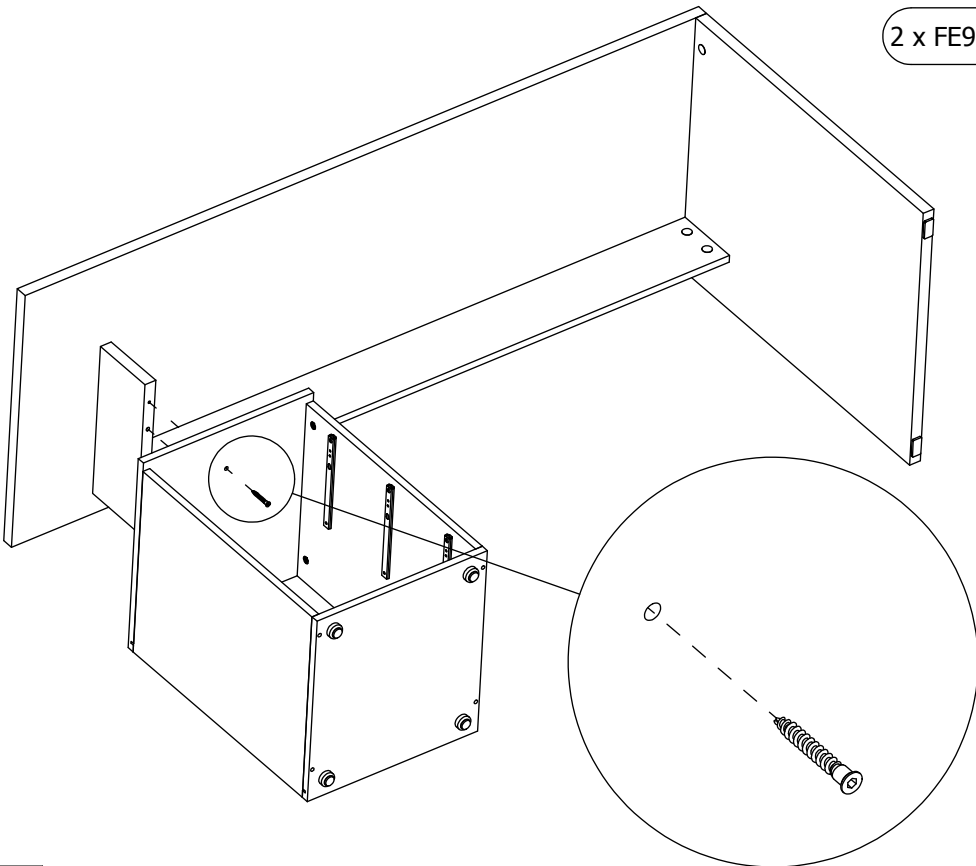

6 x FE9302 4MAx22,5

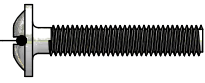

6 x FE9976 4MAx8

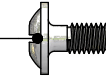

3 x FE2688A

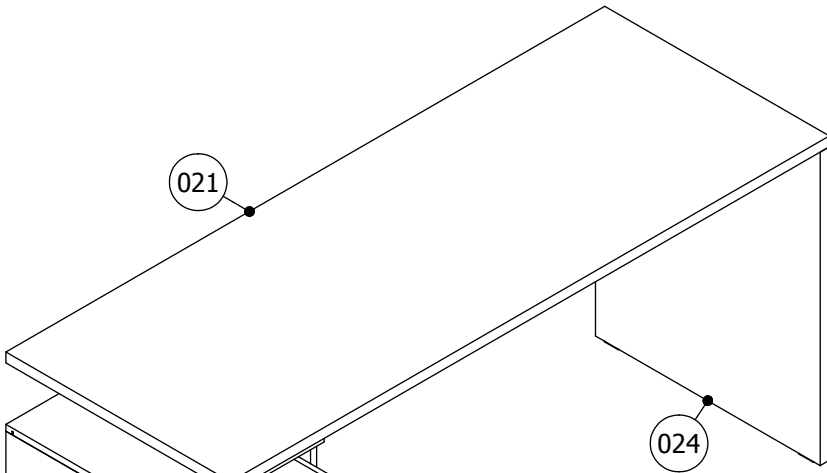
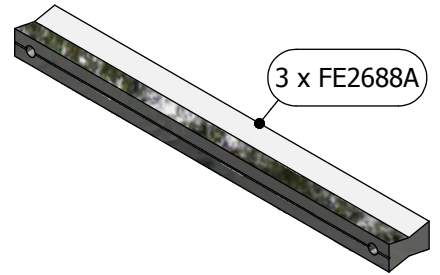

021

024

106

106

106

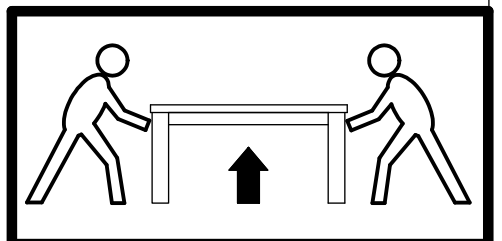
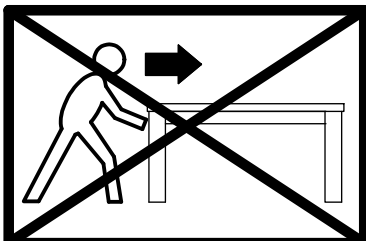
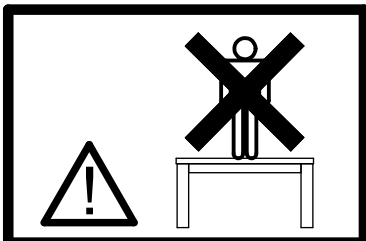
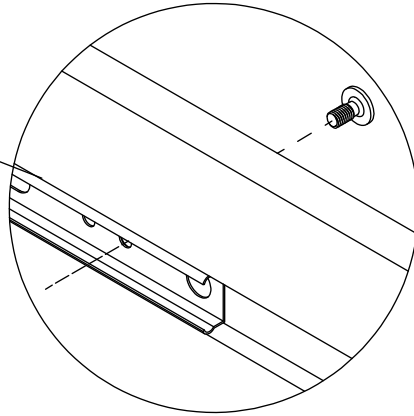

DE Pflegehinweise

Bitte nur mit einem Staubtuch oder leicht feuchtem Lappen reinigen. Keine scheuernden Putzmittel verwenden.
Schützen Sie Ihre Möbel generell vor Wasser (z.B. beim Wischen oder Blumen gießen). Die Feuchtigkeit kann in das Möbelstück eindringen und es beschädigen.

UK USA Care tips

Please only clean with a duster or a damp cloth. Do not use any abrasive cleaners. In general, keep water away from your furniture (e. g. when mopping or watering plants). The moisture may penetrate the furniture and damage it.

NL Reinigingsnotities

Reinig alleen met een stofdoek of een lichtjes vochtige doek. Gebruik geen schurende poetsmiddelen.
Bescherm uw meubelen doorgaans tegen water (bijv. bij het dweilen of als u de bloemen water geeft). De vochtigheid kan in het meubelstuk dringen en het beschadigen.

PL Wskazówki dotyczące pielęgnacji

Czyszczenie należy wykonać wyłącznie za pomocą ściereczki lub lekko nawilżonego ręcznika. Nie stosować środków czyszczących do szorowania.
Mebel należy chronić przed wodą (np. podczas czyszczenia lub podlewania kwiatków). Wilgoć może wnikać w mebel i uszkodzić go.

RU Обслуживание

Очищайте от пыли тряпкой или слегка влажной ветошью. Не допускается применение чистящих средств, не предназначенных для ухода за мебелью.
Предохраняйте мебель от попадания воды (например, при вытирании или поливке цветов). Не допускайте попадания влаги на мебель, чтобы предотвратить ее повреждение.

RO Indicații de întreținere

Vă rugăm să utilizați la curățare exclusiv o cârpă de șters praful sau o cârpă ușor umezită. Nu utilizați substa
Protejați întotdeauna mobilierul contra apei (de exemplu la stergere sau la udarea florilor). Mobilierul poate fi afectat de umiditate și se poate deteriora. Nu utilizați produse abrazive.

ES Alertas de mantenimiento

Limpe sólo con un paño húmedo, no utilice disolventes.
Proteja sus muebles de contacto con el agua. La infiltración de agua podría arruinar los muebles.

AR نصائح الرعاية

يرجى التنظيف فقط باستخدام منفضة أو قطعة قماش رطبة لا تستخدم أي منظفات خشنة أو كاشطة يمكن أن تخدش الأثاث بشكل عام، أبقِ الماء بعيداً عن الأثاث خاصة عند مسح الأرض أو سقي النباتات الرطبة قد تخترق الأثاث وتلفه

TR Bakım

Lütfen sadece bir toz beziyle veya hafif nemli yumuşak bir bezle siliniz. Aşındırıcı temizlik malzemeleri kullanmayınız.
Genelde mobilyalarınızı sudan koruyunuz (örneğin, yerleri paspaslarken veya çiçekleri sularken). Nem, mobilya parçasına nüfuz edebilir ve zarar verebilir.

IT Avvisi di manutenzione

Pulire solamente con un panno umido, non utilizzare solventi.
Proteggere i mobili dal contatto con acqua. L'infiltrazione dell'acqua potrebbe rovinare il mobile.

FR Conseil d'entretien

Nettoyer avec un plumeau ou un chiffon humide. Ne pas utiliser de dissolvants.
En général, garder l'eau loin de vos meubles (par exemple lors de lavages, ou bien pour l'arrosage des plantes). L'humidité peut pénétrer les meubles et les endommager.

CZ Ošetřování

Čistěte prosím jen prachovkou nebo lehce navlhčeným hadrem. Nepoužívejte drhnoucí čisticí prostředky.
Chraňte váš nábytek před vodou (např. při utírání prachu nebo zalévání květin). Vlhkost může do nábytku proniknout a poškodit ho.

SK Ošetrovanie

Na čistenie používajte len prachovku alebo zľahka navlhčenú utierku. Nepoužívajte žiadne drhúce čistiace prostriedky.
Chrňte váš nábytok celkovo pred vodou (napr. pri utieraní alebo polievaní kvetín). Vlhkosť môže vniknúť do nábytku a poškodiť ho.

HU Ápolási tanácsok

Kérjük, csak portörölő kendővel vagy enyhén nedves ronggyal tisztítsa. Ne használjon dörzsölhető tisztítószert.
Védje a bútort a víz ellen (pl. a letörölés során, ill. a növények öntözésekor). A nedvesség behatolhat a bútortá és azt tönkre teheti.

PT Alertas de manutenção

Limpe apenas com um pano úmido, não use solventes.
Proteja sua mobília de contacto com a água. A infiltração de água pode arruinar o mobiliário.

