

80-20101-40

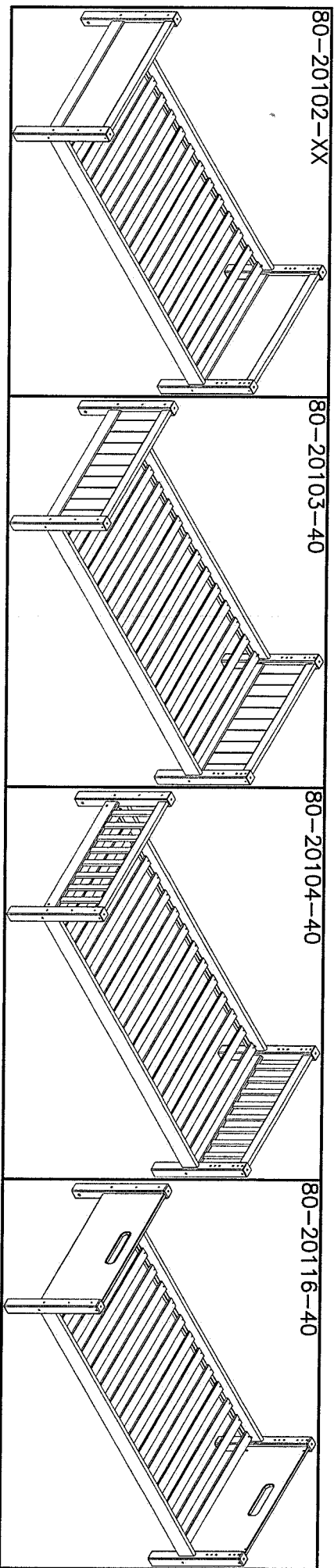

See assembly instruction in box no.
 Voir notice de montage dans la caisse no.
 Siehe Aufbauanleitung im Karton no.
 Zie voor de montage-instructie pakketnr.

Before assembling this product, please ensure that all the components supplied comply with the list on this page. All Screw-type fittings can be tightened with this tool.

Avant de commencer l'assemblage, veuillez contrôler si tous les objets indiqués sont présents. Tous les vis peuvent être serrés par cet outil.

Bevor Sie mit dem Aufbau beginnen, kontrollieren Sie ob alle auf der Zeichnung angegebenen Teile vorhanden sind. Bitte verwenden Sie zur Montage einen Kreuzschraubenzieher und den beiliegenden Innensechskantschlüssel.

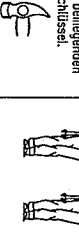
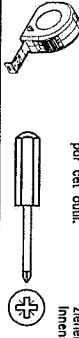

Ware-nr. Part no. Ref No	Stück. Qty. Qte.
Siehe Bild-nr. See picture no. Image no	Mass Dim. Dim.

12-06306473-40	2 stck./pcs.	12-06306474-40	2 stck./pcs.	1305-19672-40	2 stck./pcs.																		
	2 stck./pcs.		2 stck./pcs.		2 stck./pcs.																		
A 3922-08018 B stck./pcs. 3930-10050 16 stck./pcs. 3909-70100	647x63x63 B	B 647x63x63 C	3901-40030	30 stck./pcs.	1967x115x26																		
Z1 M8/ø12x18 mm. 3913-08110		Z2 ø10x50 mm. 3938-000081-2		Z3 16 stck./pcs.	Z4 ø7x100 mm. 3938-00010-2		20 stck./pcs.	Z5 ø4x30 mm. 4033-005		4 stck./pcs.	Z6 M8x110 mm. 3938-00016-2		4 stck./pcs.	Z7 ø8 mm. 3938-00016-2		16 stck./pcs.	Z8 ø10 mm. 4033-005		4 stck./pcs.	Z9 1967x115x26		1 stck./pcs.	5 mm.

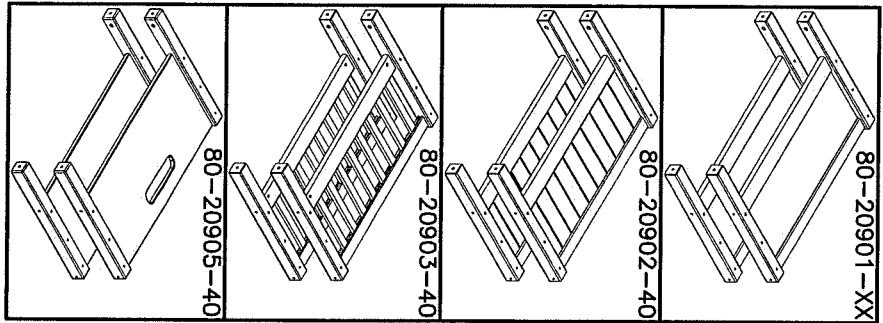

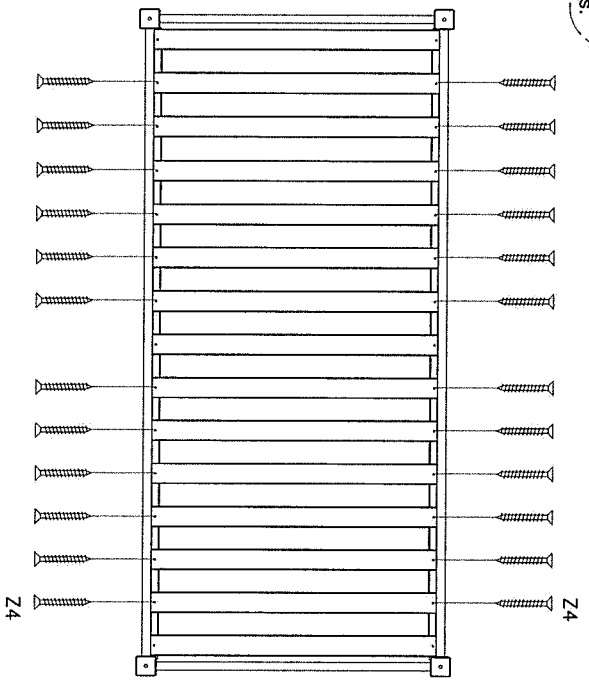
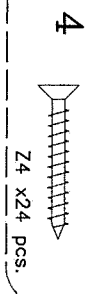
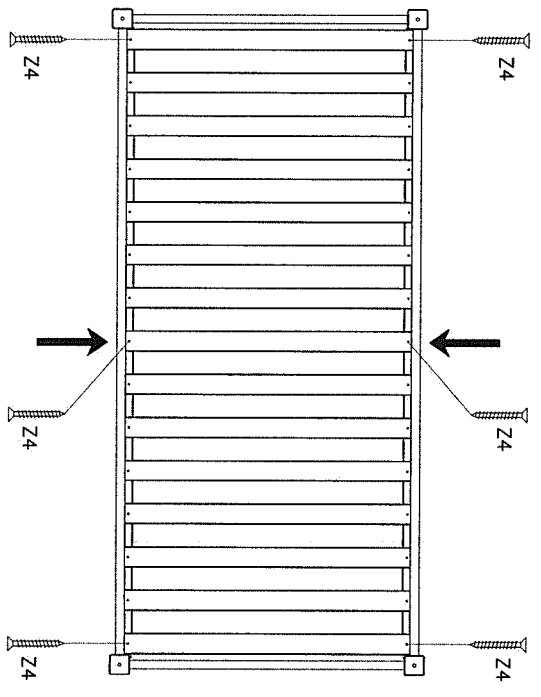
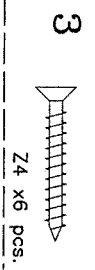
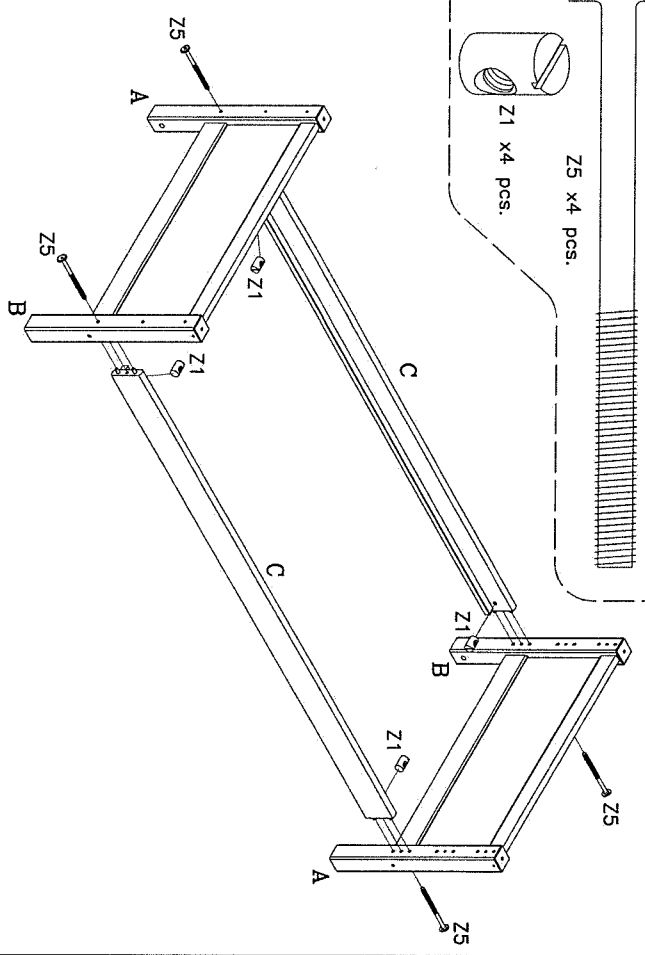
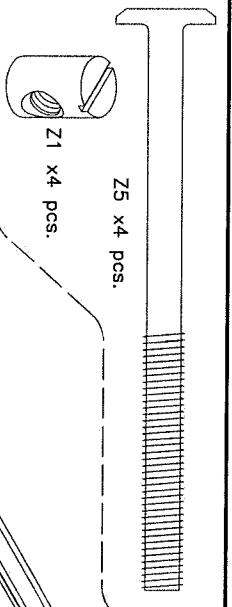
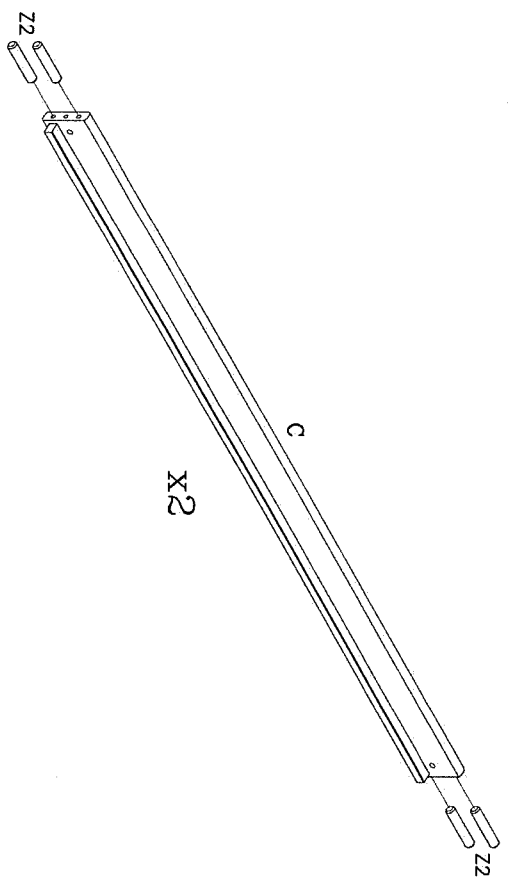
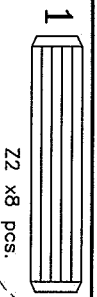

80-20905-40 White

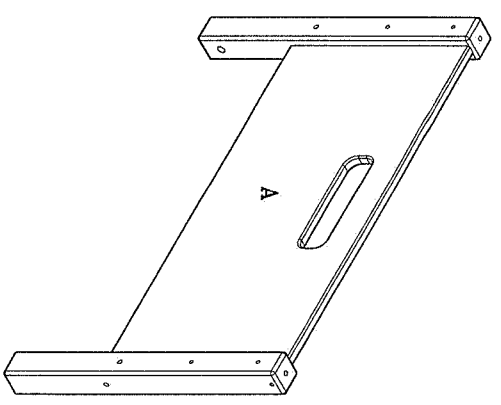

Before assembling this product, please ensure all the components supplied comply with the list on this page. All Screw-type fittings can be tightened with this tool.

Avant de commencer l'assemblage, veuillez vérifier si tous les composants inclus sont conformes à la liste par cet outil.

Bevor Sie mit dem Aufbau beginnen, überprüfen Sie ob alle auf der Zettelliste angegebenen Teile vorhanden sind. Bitte verwenden Sie zur Montage einen Kreuzschraubenzieher und den beiliegenden Innensechskantschlüssel.

Bitte-nr. / Part no. / Ref. No. / Siehe Bild-nr. / See picture no. / Inonge no. / Mass Dim. / Qty. / Dte.

4301-2208631-40	2 stick/ pcs.		M6/Ø10x18mm	4 stick/ pcs.	4033-004	1 stick/ pcs.	4 mm.
			M6x110 mm.	4 stick/ pcs.			
			3922-060181	4 stick/ pcs.			
			3913-06110				
			863x431x22	Z29			

Z1, Z2, Z5 Fittings in single / bunk bed box.
 Z1, Z2, Z5 Beschläge im Einzel- / Etagenbett Karton.
 Z1, Z2, Z5 Raccords en lit simple / lit superposé.
 Z1, Z2, Z5 Fittings in het enkelspel / stapelbed boxen.

<p>1</p> <p>Z2 x8 pcs.</p> <p>Z29 x2 pcs. Z5 x2 pcs. Z1 x2 pcs. Z28 x2 pcs.</p> <p>Z29 x2 pcs. Z5 x2 pcs. Z1 x2 pcs. Z28 x2 pcs.</p> <p>Bunk bed only. Nur Etagen Bett. Lits superposés seulement. Alleen stapelbed</p>	<p>3a</p> <p>Z29 x2 pcs. Z5 x2 pcs. Z1 x2 pcs. Z28 x2 pcs.</p> <p>Z29 x2 pcs. Z5 x2 pcs. Z1 x2 pcs. Z28 x2 pcs.</p>
--	--

80-20510-40

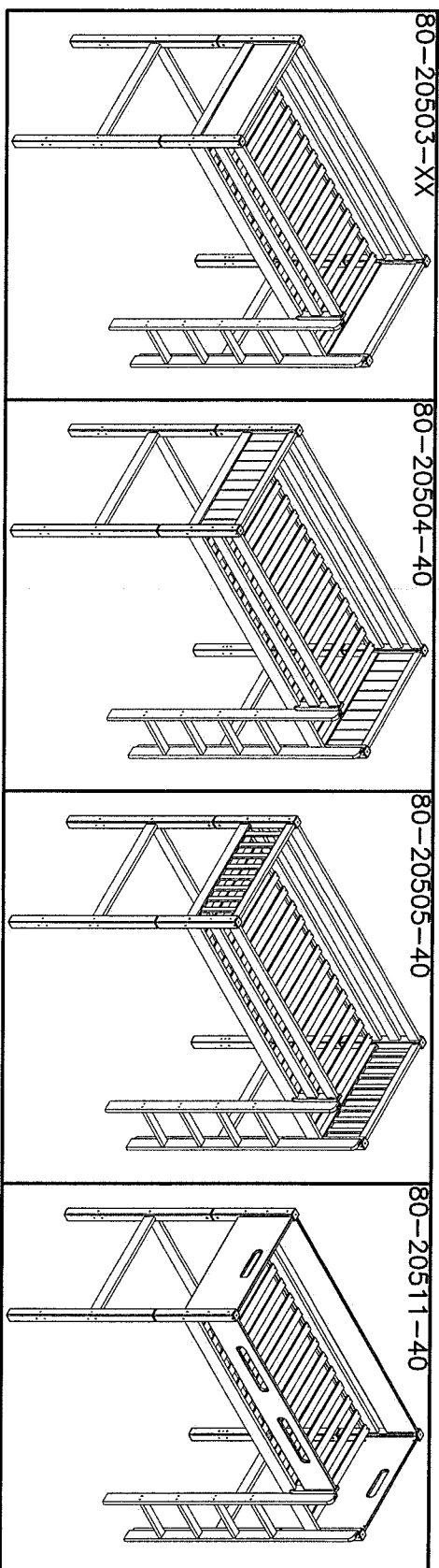

80-20503-XX

80-20504-40

80-20505-40

80-20511-40

Before assembling this product, please ensure that all the components supplied comply with the list on this page. All Screw-type fittings can be tightened with this tool.

Avant de commencer l'assemblage, veuillez vérifier que tous les objets présents dans les présentés. Tous les vis à tête sont à serrés par cet outil.

Bevor Sie mit dem Aufbau beginnen, überprüfen Sie ob alle auf die Zeichnung angegebenen Teile vorhanden sind. Bitte verwenden Sie zur Montage einen Kreuzschraubzieher und den beiliegenden Innensechskantschlüssel.

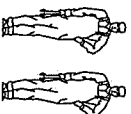

Ware-nr.
Part no.
Ref No

Siehe Bild-nr.
See picture no.
Image no

Stück.
Qty.
Qté.

Mass
Dim.
Dim.

See assembly instruction in box no. 80-20101-40

Voir notice de montage dans la coisse no. 80-20101-40

Siehe Aufbauanleitung im karton no. 80-20101-40

Zie voor de montage-instructie pokkeintr. 80-20101-40

12-02603182-40	4 stick/pcs	12-02618331-40	2 stick/pcs	12-02619676-40	1 stick/pcs	12-06311863-40	2 stick/pcs	3922-060181	8 stick/pcs	3913-06070	2 stick/pcs				
A	318x65x26	1 stick/pcs	D	1833x89x28	1 stick/pcs	4301-2219675-40	1967x89x26	G	1186x63x63	2 stick/pcs	Z28	M6/ø10x18mm	Z30	M6x70 mm	6 stick/pcs
12-02603611-40	361x65x26	2 stick/pcs	B	4301-2219675-40	1967x89x26	12-06311864-40	1186x63x63	Z29	M6x110 mm	3938-000081-2	28 stick/pcs	3938-00010-2	12 stick/pcs		
C	863x89x28	3909-70100	E	1571x248x22	1967x248x22	H	1186x63x63	Z6	ø8 mm, Z7	ø10 mm	Z7	ø10 mm			
3930-10050	12 stick/pcs	3909-70100	10 stick/pcs	3901-40030	6 stick/pcs	3938-00016-2	4 stick/pcs	3903-40025	4 stick/pcs	3907-63022	4 stick/pcs	3917-10012	4 stick/pcs		
Z2	ø10x50 mm	Z3	ø7x100 mm	Z4	ø4x30 mm	Z8	ø16 mm	Z9	ø4x25 mm	Z10	M10/ø10x115 mm	Z11	M10x12 mm		
4007-014	2 stick/pcs	4008-021	4 stick/pcs	3922-100028	4 stick/pcs	3909-70060	16 stick/pcs	3934-10115	4 stick/pcs	3933-15028	4 stick/pcs	3901-30020	2 stick/pcs		
Z12	15,5x3 mm	Z13	20x20x16x2 mm	Z14	M10/ø15x28 mm	Z15	ø7x60 mm	Z16	M10/ø10x115 mm	Z17	ø15x28 mm	Z18	ø3x20 mm		

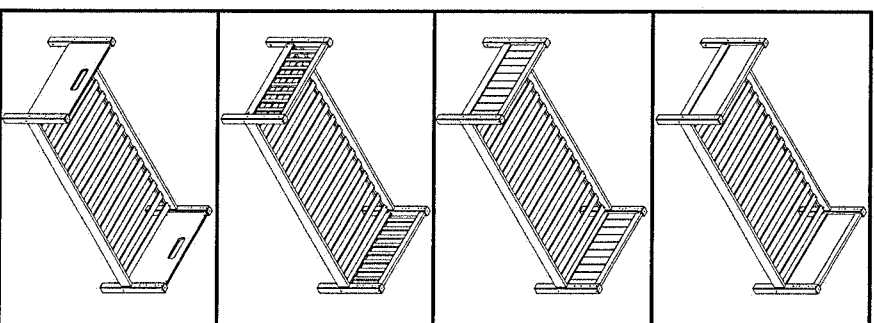

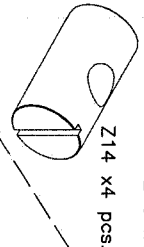
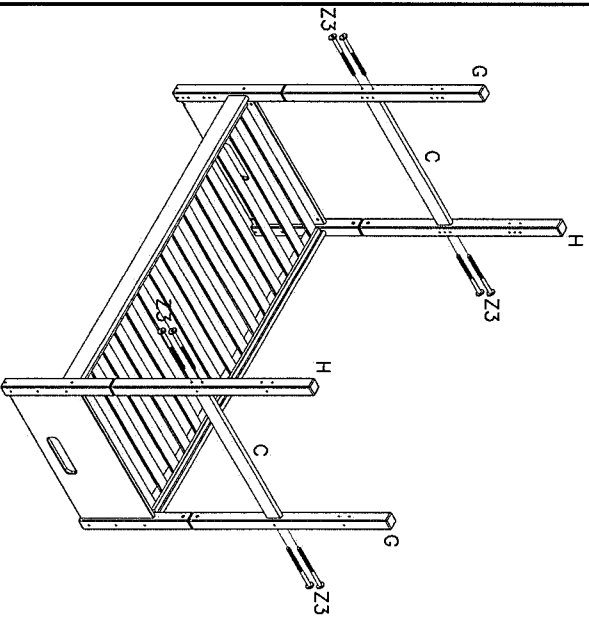
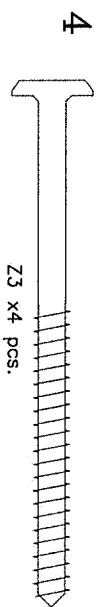
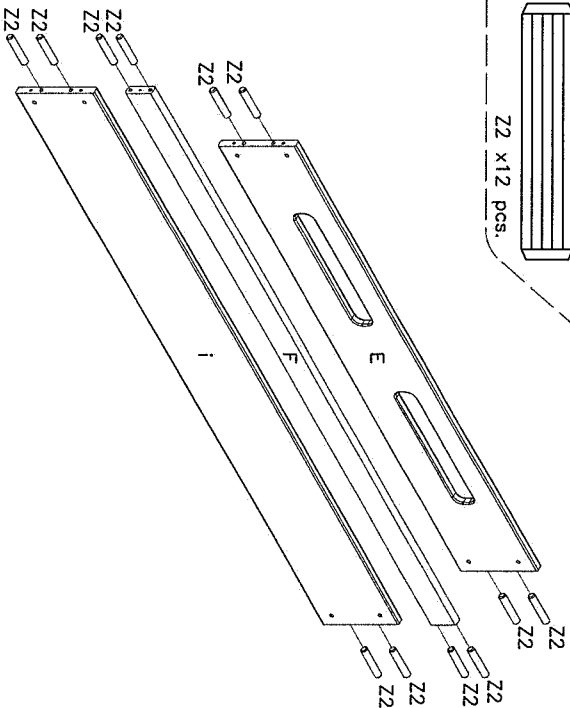
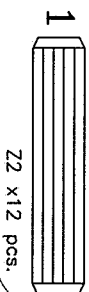

Screw the bolt Z16 into the leg, until the ring on the bolt is flush with the end of the leg.
 Schroef de bout Z16 in de poot, tot de ringruitering op de bout gelijkvalt met de bovenzijde van de poot.
 Der Verbindungsbolzen Z16 wird eingeschraubt, bis der markierte Ring mit der Oberkante des Pfostens bündig ist.
 Visser le goujon dans le pied jusqu'à ce que l'anneau gravé soit à fleur avec le bois.

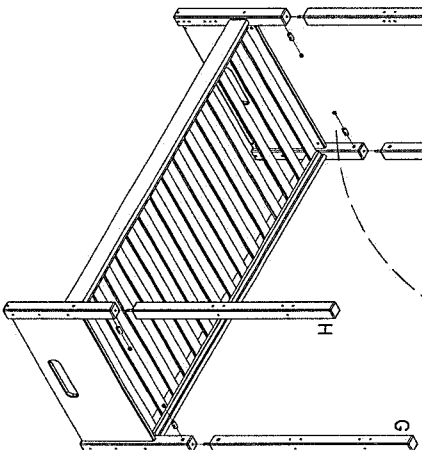
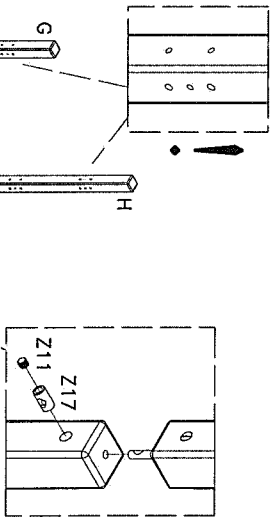
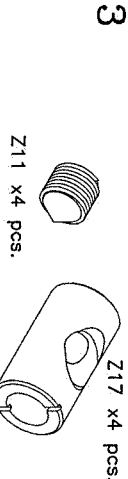
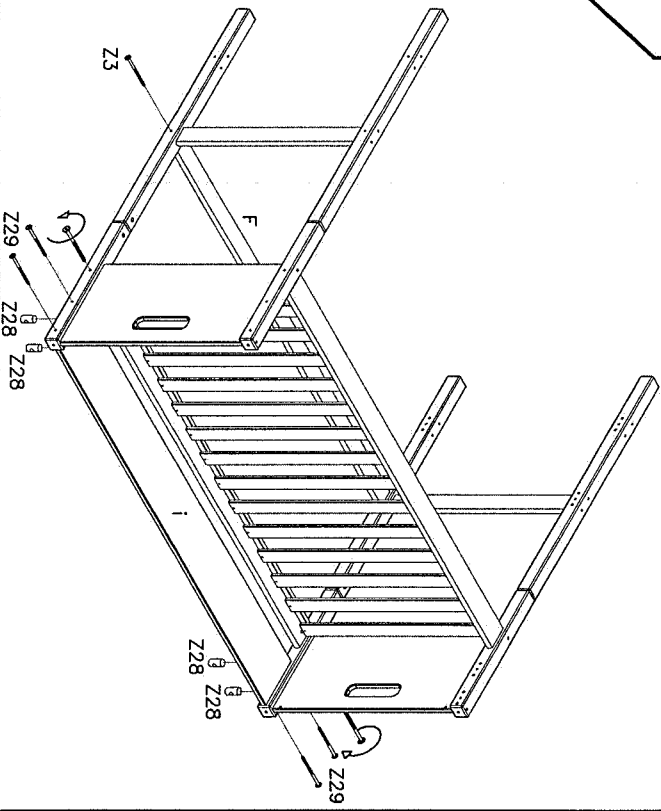
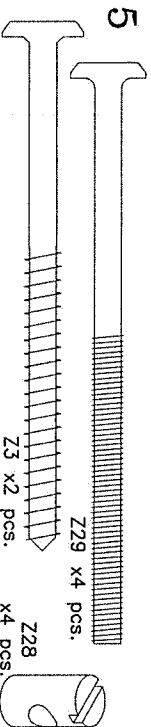
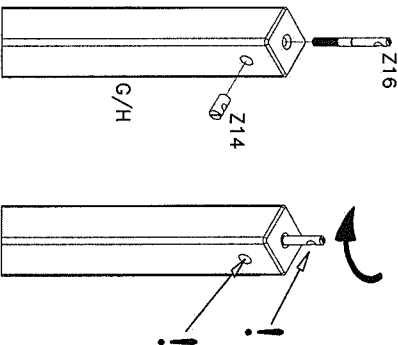

If the leg is loose after assembly, loosen the screw Z11 slightly, until the lower leg can be turned 1 time around clockwise. Then tighten the Z11 screw again.
 Indien de poot na montage niet vast genoeg zit, dient u schroef Z11 iets los te draaien, tot de onderste poot 1 keer rechtsom gedraaid kon worden. Daarna kunt u schroef Z11 weer vastschroeven.
 Wenn die Pfosten nicht fest genug angezogen sind, muss die Schraube Z11 leicht gelöst werden, bis der untere Pfosten 1 Mal rechts herum gedreht werden kann. Dann muss die Schraube Z11 wieder gespannt werden.
 Si les deux montants de pied ne sont pas suffisamment serrés, il convient de desserrer légèrement le vis Z11, jusqu'à pouvoir tourner la partie inférieure du pieds 1 fois dans le sens des aiguilles d'une montre. Ensuite resserrer le vis Z11.

6

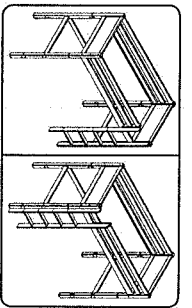
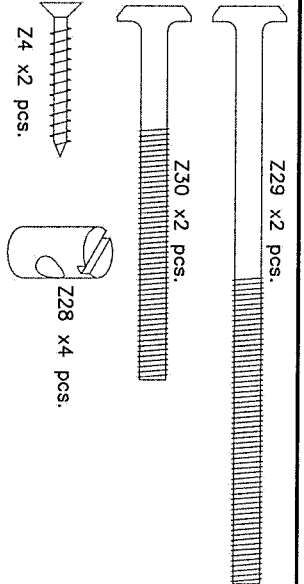

DK: Max. madrashøjde
 D: Max. Höhe der Matratze
 GB: Max. height of mattress
 E: Hauteur max. du matelas
 F: Altezza max. materasso
 I: Altura del colchón máximo
 NL: Maximale matrashoogte
 CN: 床垫最大高度

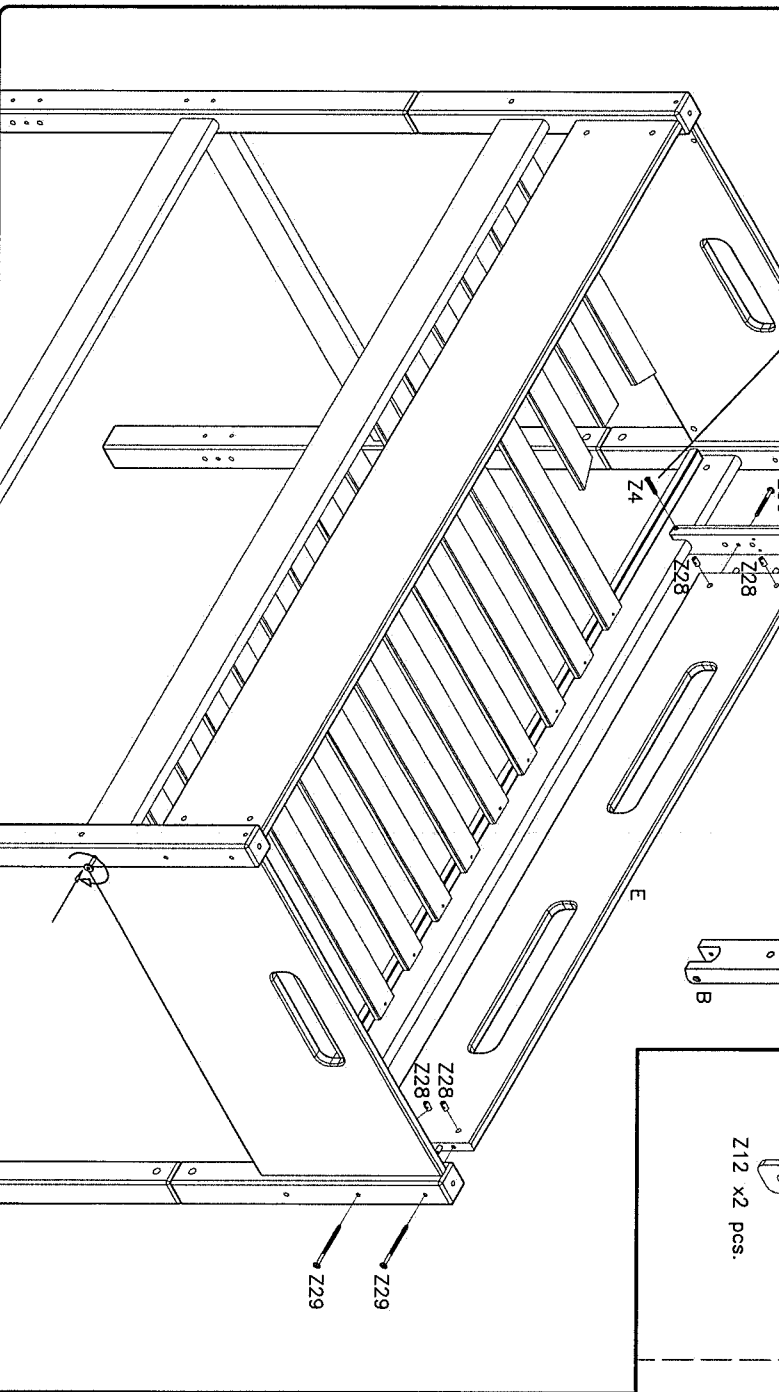
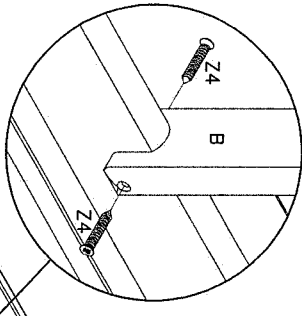

7

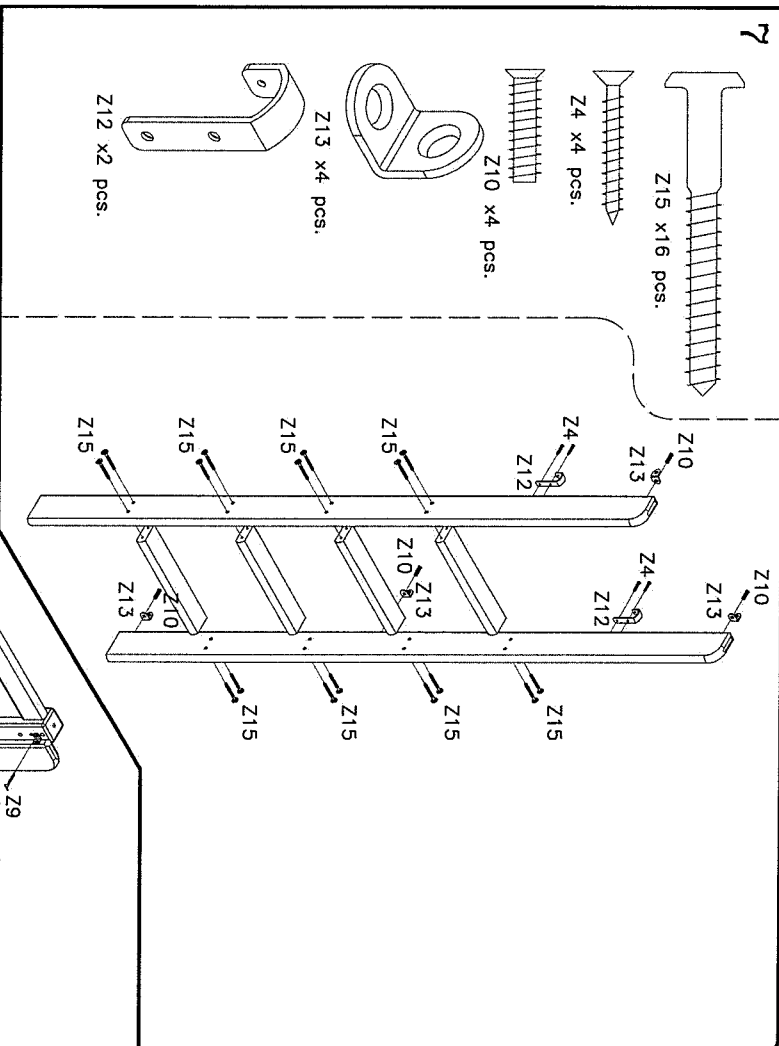
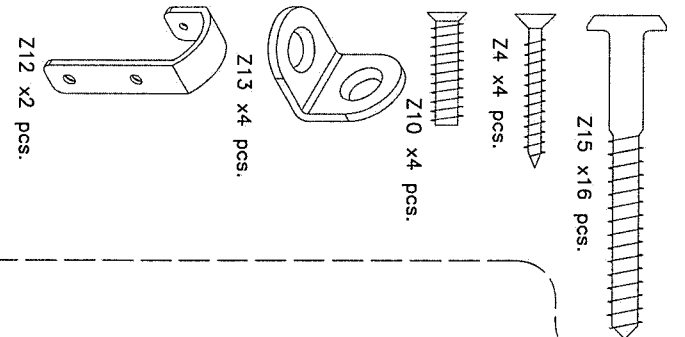

8

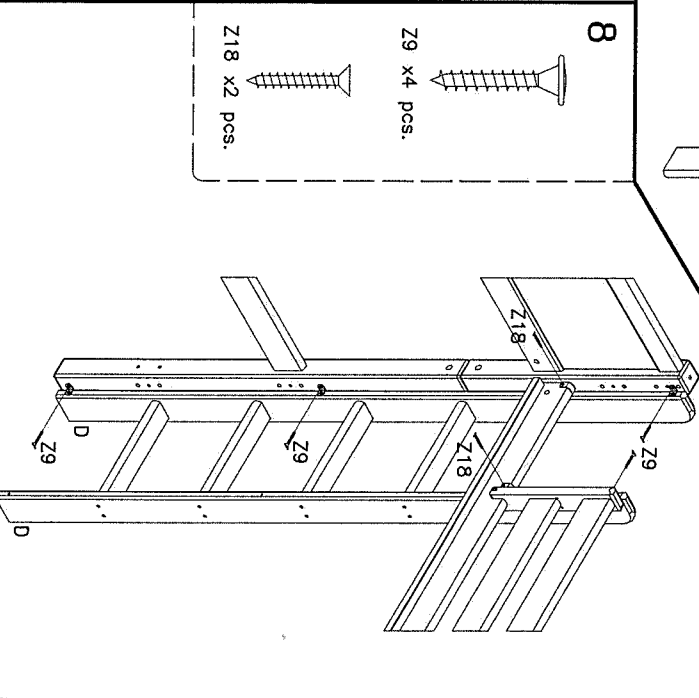
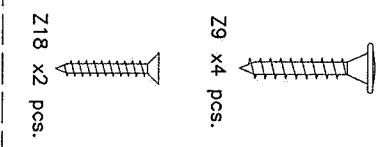

82-50086-40 200cm

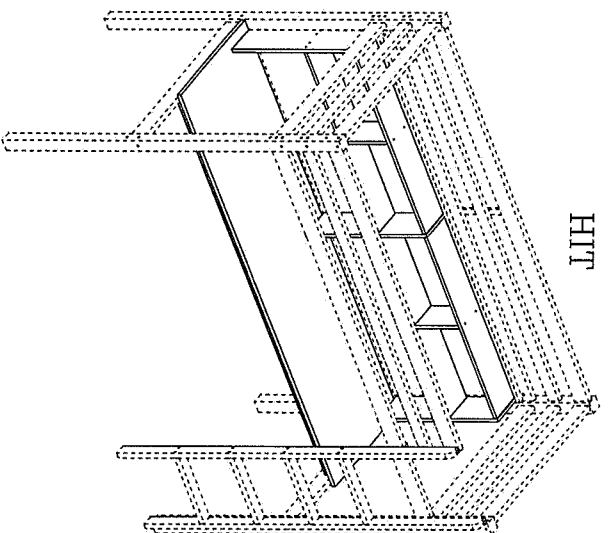
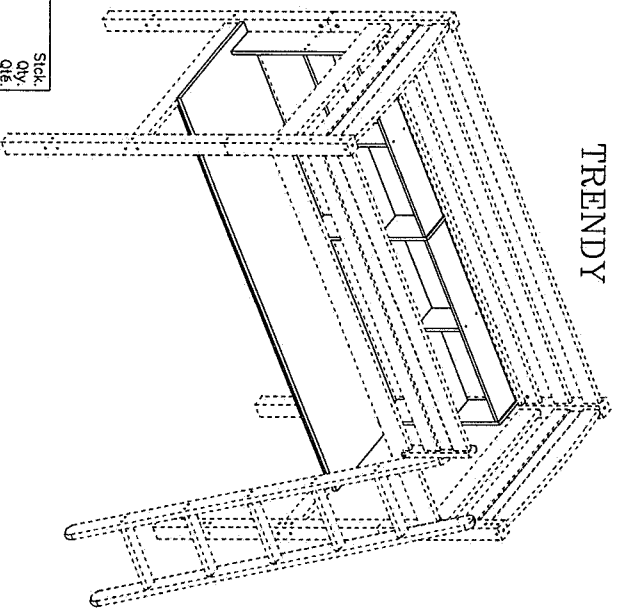
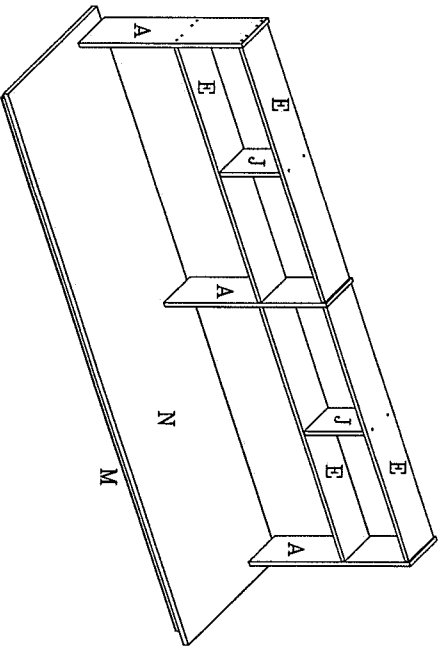

Before assembling this product, please ensure that all the components supplied comply with the list on this page. All Screw-Type fittings can be tightened with this tool.

Avant de commencer l'assemblage, veuillez contrôler si tous les objets indiqués sont présents. Tous les vis peuvent être serrés par cet outil.

Bevor Sie mit dem Aufbau beginnen, kontrollieren Sie ob alle auf der Zeichnung angegebenen Teile vorhanden sind. Bitte verwenden Sie zur Montage einen Kreuzschraubenzieher und den beiliegenden Inmensschlüssel.

More-nr.
Part no.
Réf. No.

Stück.
Qty.
Qte.

Steh-Bild-nr.
See picture no.
Image no.

Mess
Dim.
Dim.

15-01506451-40 3 stick/pcs.	15-01502411-40 2 stick/pcs	12-01520031-40 1 stick/pcs.	12-01519951-40 1 stick/pcs.
--------------------------------	-------------------------------	--------------------------------	--------------------------------

4020-005 8 stick/pcs.	4020-006 8 stick/pcs.	3933-15010 16 stick/pcs.	3924-04015 4 stick/pcs.	3930-05030 16 stick/pcs.	3901-45055 6 stick/pcs.	15-01820701-40 1 stick/pcs.
--------------------------	--------------------------	-----------------------------	----------------------------	-----------------------------	----------------------------	--------------------------------

Z1 65x34 mm. 17 stick/pcs.	Z2 Max:34 mm. 6 stick/pcs.	Z3 ø15x9,5 mm. 5 stick/pcs.	Z4 ø5MMx15 mm. 1 stick/pcs.	Z5 ø5x30 mm. 1 stick/pcs.	Z8 ø4,5x35 mm. 8 stick/pcs.
----------------------------------	----------------------------------	-----------------------------------	-----------------------------------	---------------------------------	-----------------------------------

Z11 ø3,5x20 mm.	Z12 ø7x40 mm.	Z15 50x50x15 mm.	Z17 4 mm.	Z9 ø4x40 mm.	N 2070x575x18
--------------------	------------------	---------------------	--------------	-----------------	------------------

TRENDY - NORDIC

HIT

Ref.no. 44-01339-40 B1 Smnt: 210217 Page 1-2

