

Art. Nr. 4134 7027, 1038 3732, 9162 6769

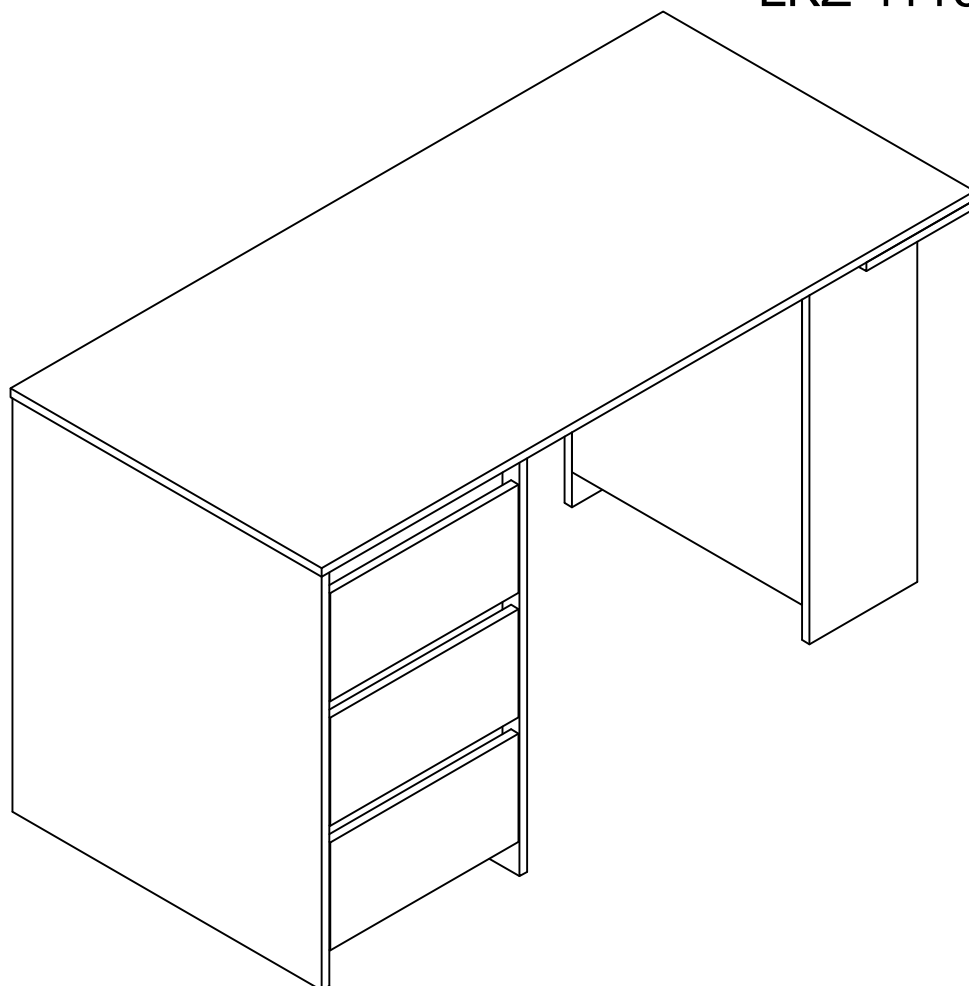

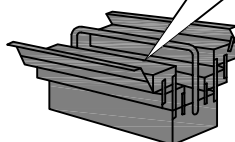

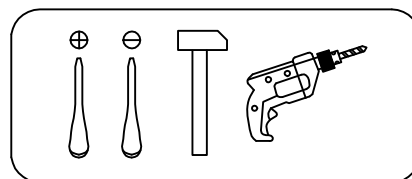

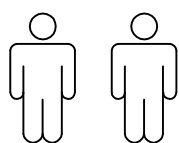

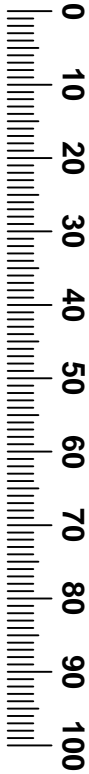







LKZ 41164



- | | |
|---|-------------------------------------|
| (D) Montageanleitung | (GB) Assembly instructions |
| (FR) Notice de montage | (IT) Istruzioni di montaggio |
| (NL) Handleiding voor de montage | (PL) Instrukcja montazu |
| (CZ) Montážni návod | (SK) Návod na montáž |
| (HU) Szerelési útmutató | (RO) Instrucțiuni de montaj |
| (TR) Montaj talimati | (RU) Инструкция по монтажу |





A 000146  15x12 x40	B 090912  15x10 x18	C 090913  7x32 x58	D 000151  8x35 x36	M 000084  6x25 x4	F 155999  x1
G 000754  3.5x16 x2	H 090185  4.5x45 x1	I 013859  8x40 x1	J 101608  7x50 x12	K 168891  L550 x3	L 000767  3x13 x18
M 000762  3.5x13 x18	N 098889  x18	O 030579  x16	P 101777  70x50 x4	Q 100640  20x0.5 x20	

N	Size/MaB (mm)	Qty	✓	N	Size/MaB (mm)	Qty	✓
1	759x654x16	1		10	486x211x16	3	
2	759x654x16	1		11	402x64x16	1	
3	743x228x16	1		12	402x64x16	3	
4	743x228x16	1		13	486x64x16	1	
5	759x402x16	1		14	398x198x16	3	
6	486x679x16	1		15	550x150x12	3	
7	715x200x16	1		16	550x150x12	3	
8	1380x658x16	1		17	353x150x12	3	
9	658x229x16	1		18	547x363x3	3	

Service - Dienstverlening - Serwis - Servis - Сервисная служба

Name - Naam - Nazwa - Isim - Название

Nr. - No. - Номер

Typ - Type - Тип - Тип

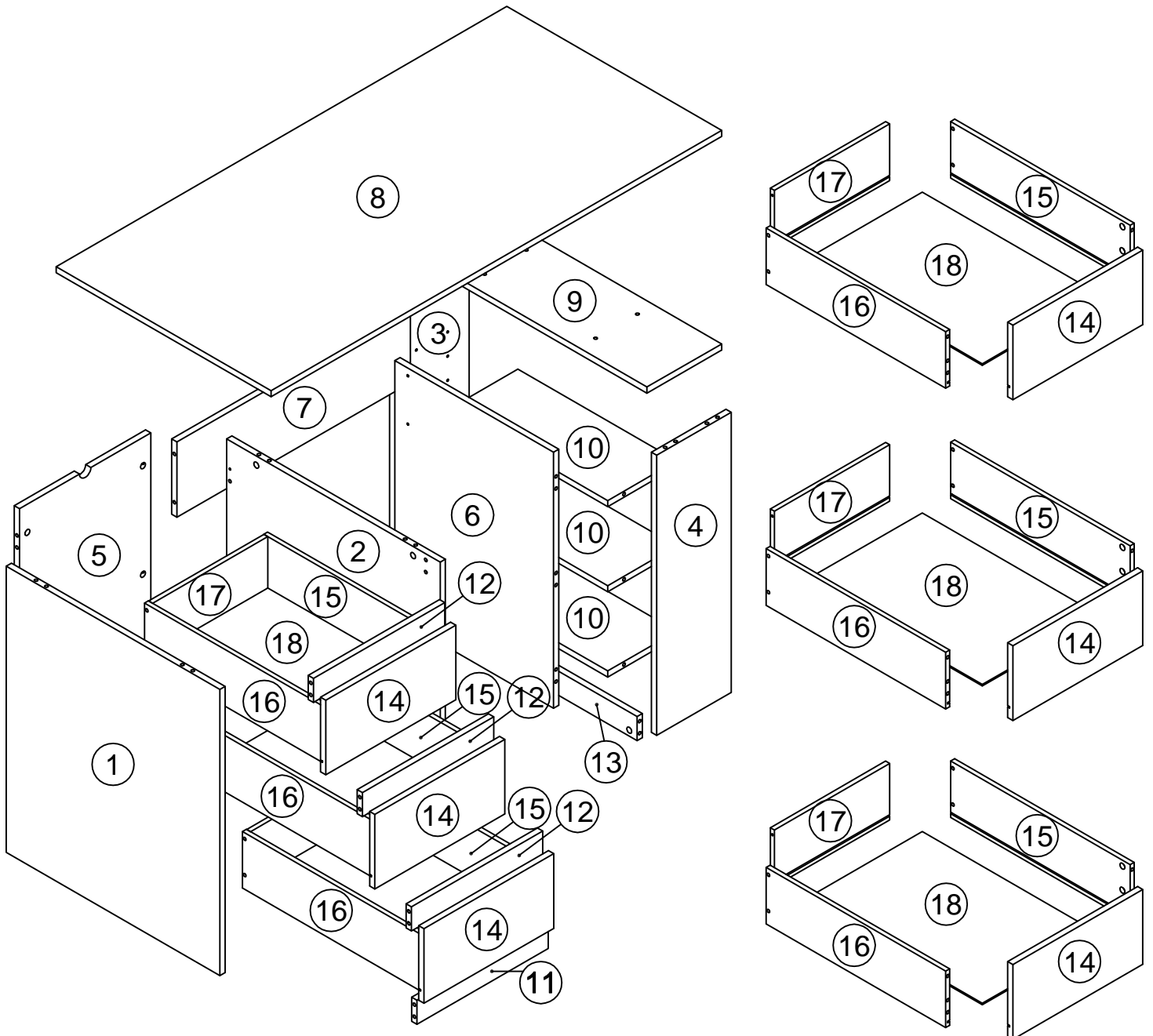
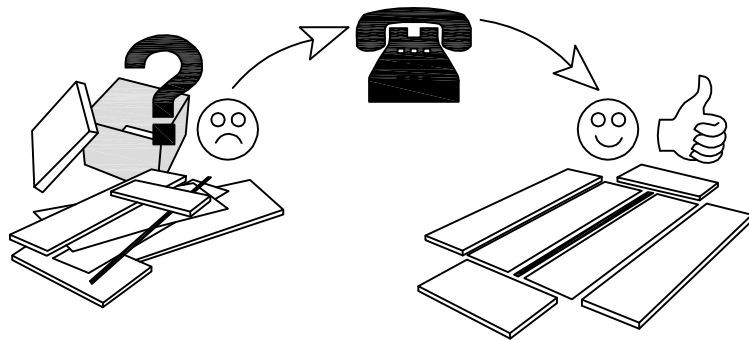
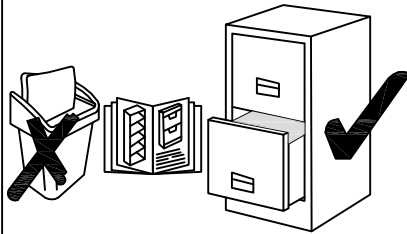

1

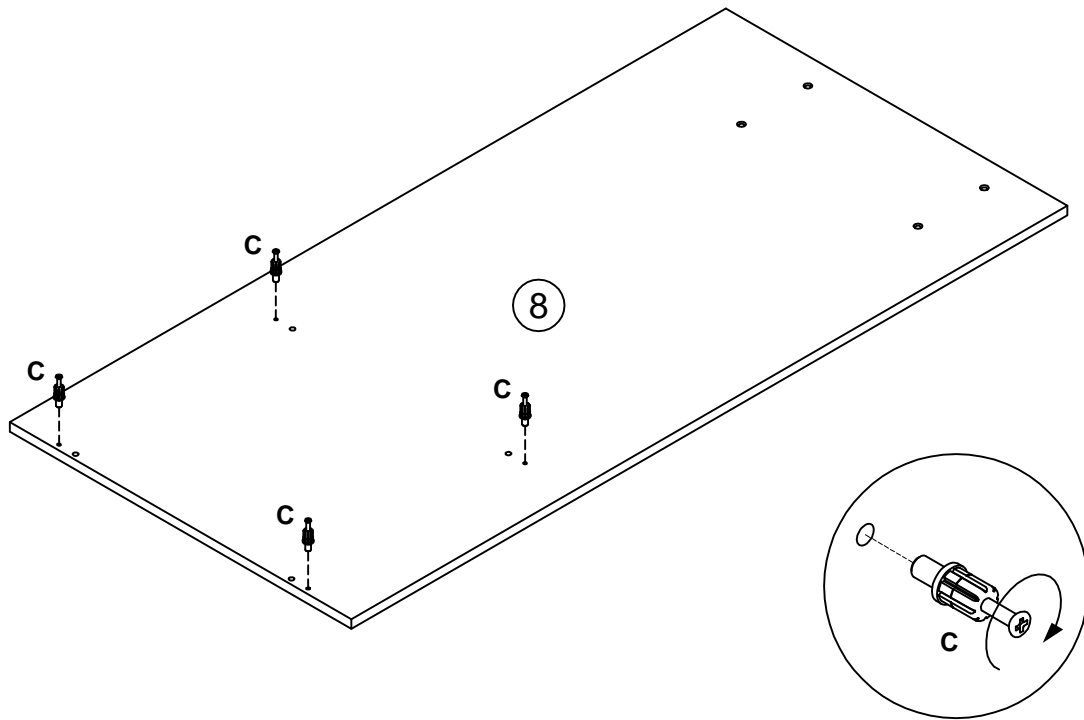
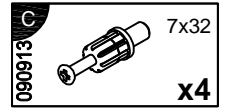

2

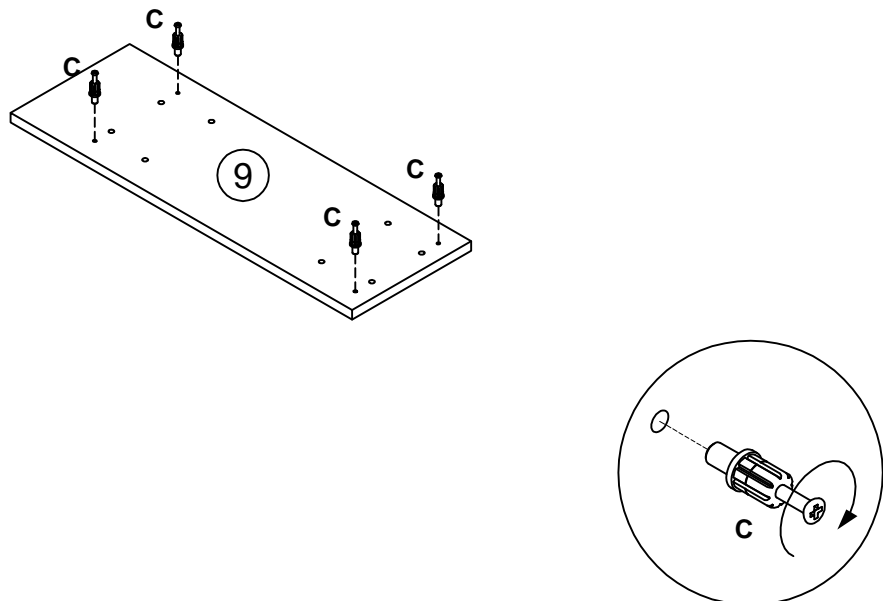
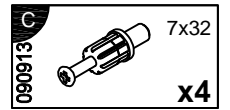

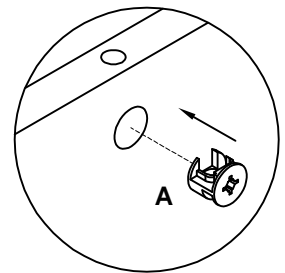
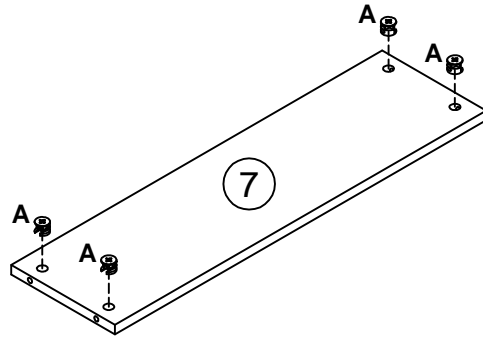

3

A		15x12
000146		x4



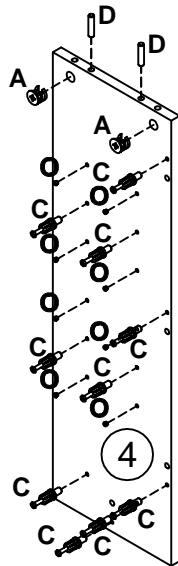
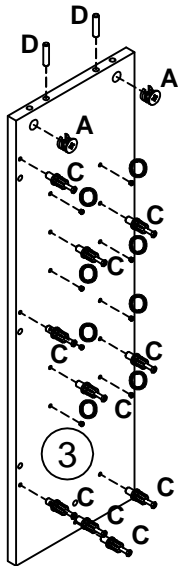

4



A		15x12
000146		x4

C		7x32
090913		x20

D		8x35
000151		x4

O		x16
030579		

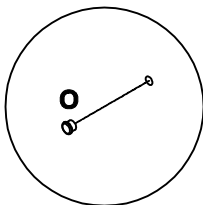
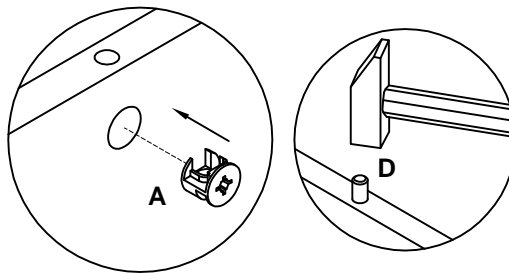
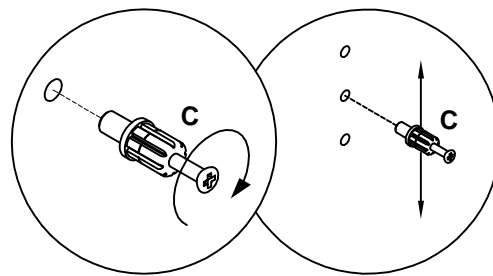

5

5 x3

A 000146 15x12
x12

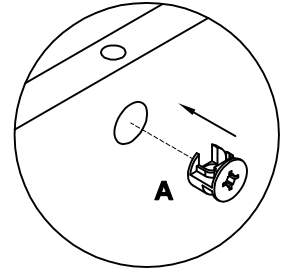
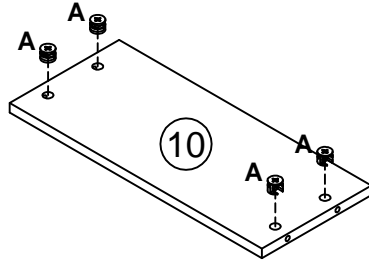

6

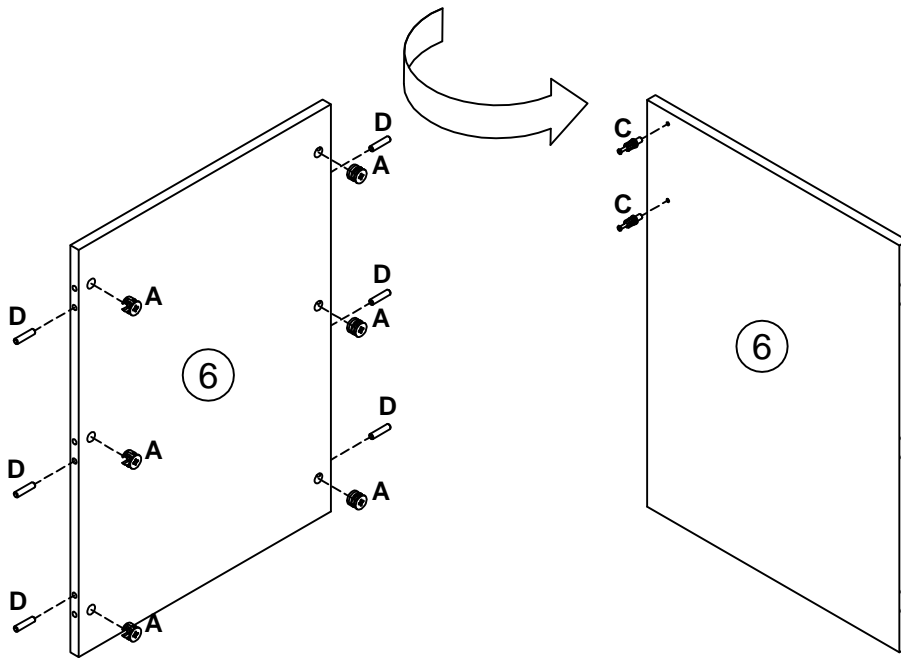

A 000146 15x12
x6

C 090913 7x32
x2

D 000151 8x35
x6

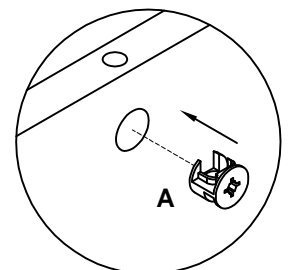
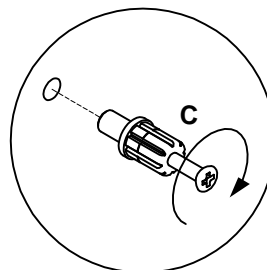

7

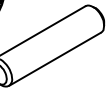
A		15x12
000146		x6
D		8x35
000151		x6

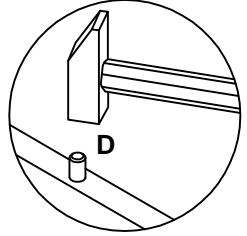
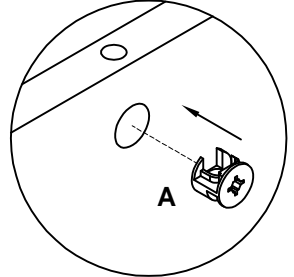
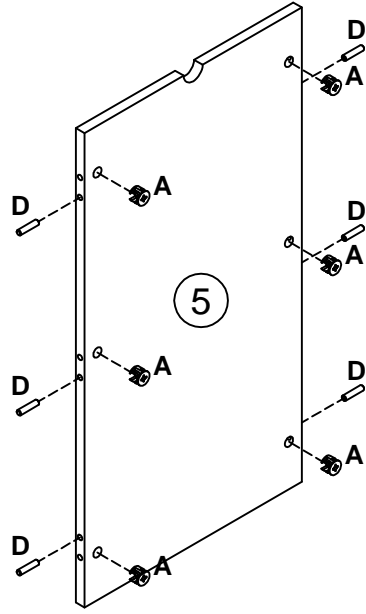

8

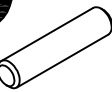
A		15x12
000146		x4
D		8x35
000151		x4

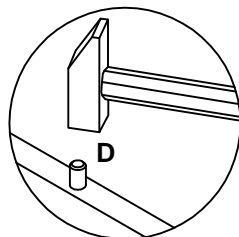
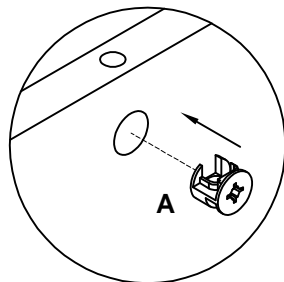
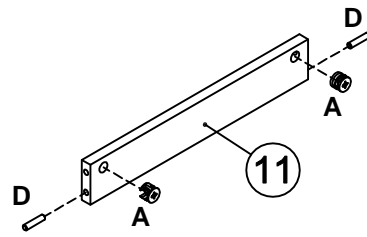
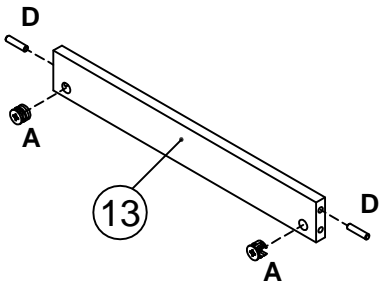

9 x3

D 000151 8x35 x12

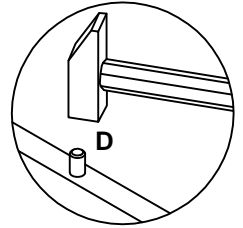
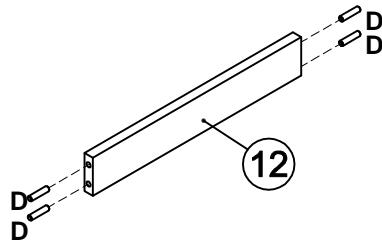

10

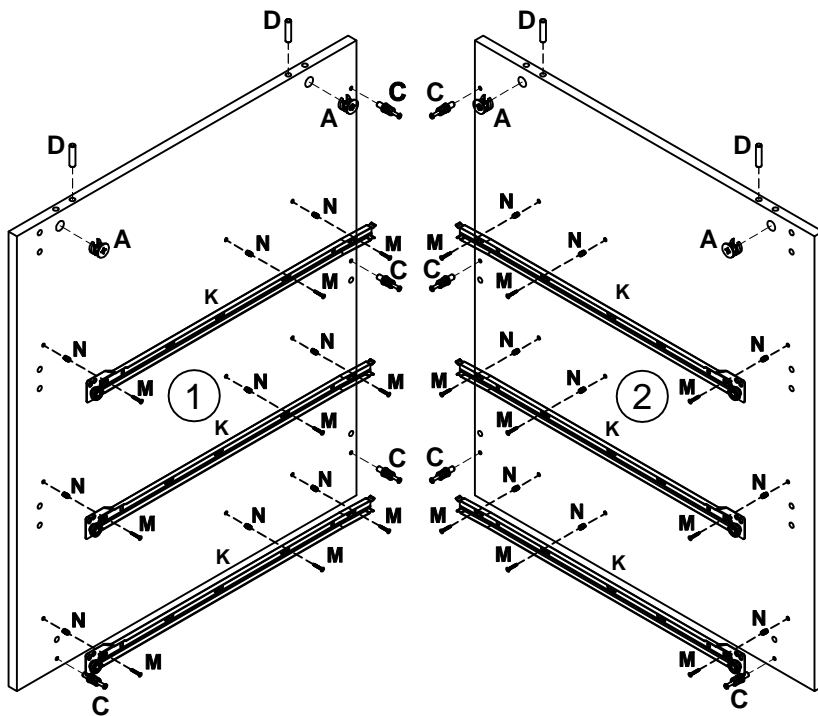

A 000146 15x12 x4

C 090913 7x32 x8

D 000151 8x35 x4

K 168891 L550 x3

M 000762 3.5x13 x18

N 098889 x18

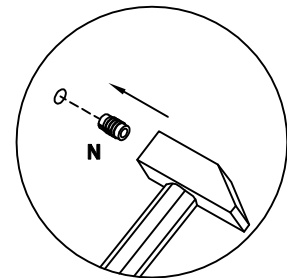
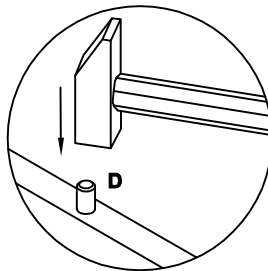
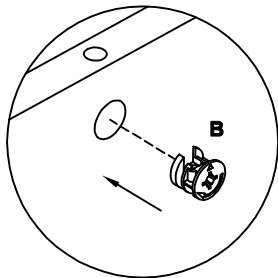
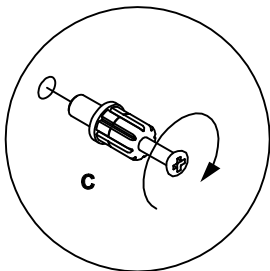
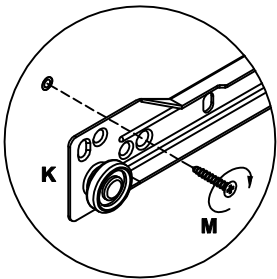

11

090913 **C** 7x32
x2

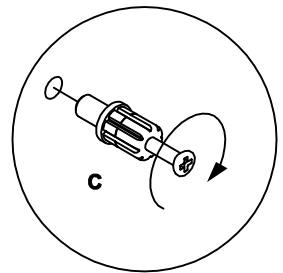
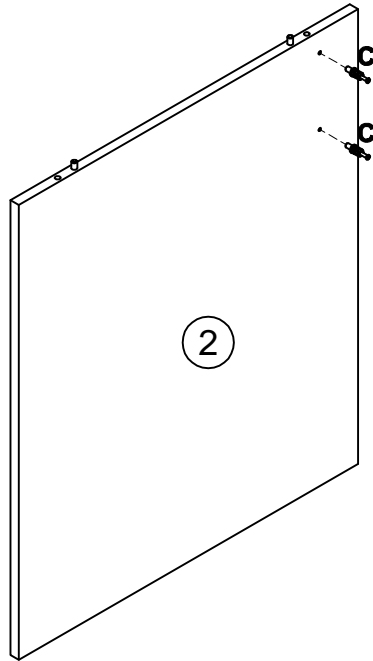

12 x3

090912 **B** 15x10
x18

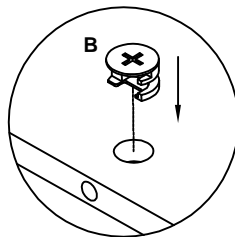
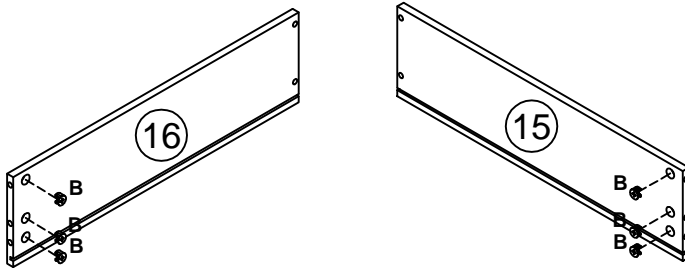

13 x3

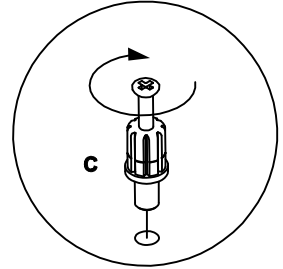
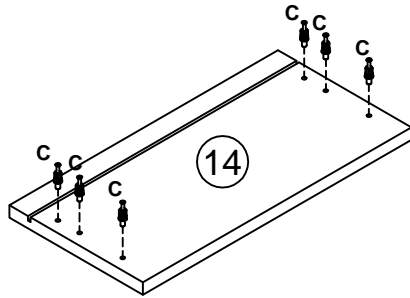
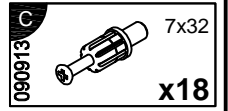

14 x3

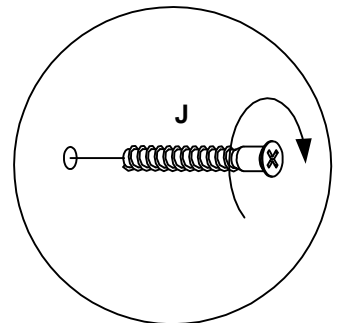
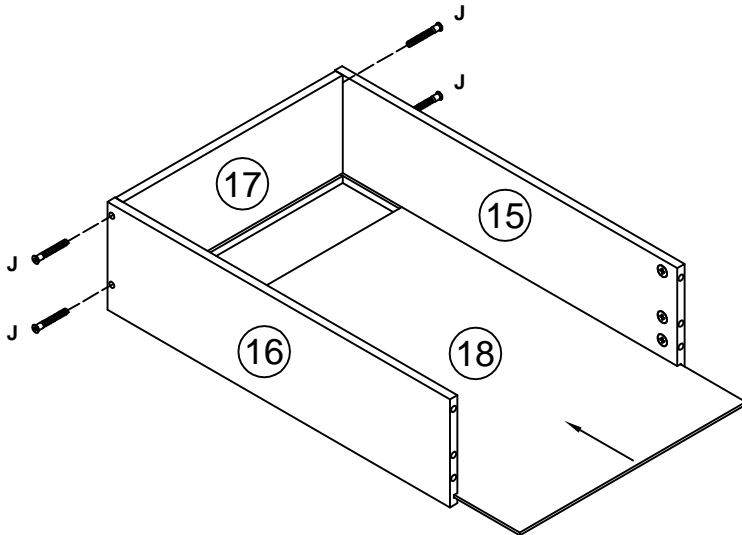
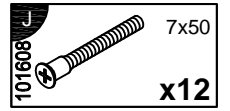

15 x3

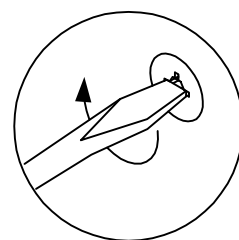
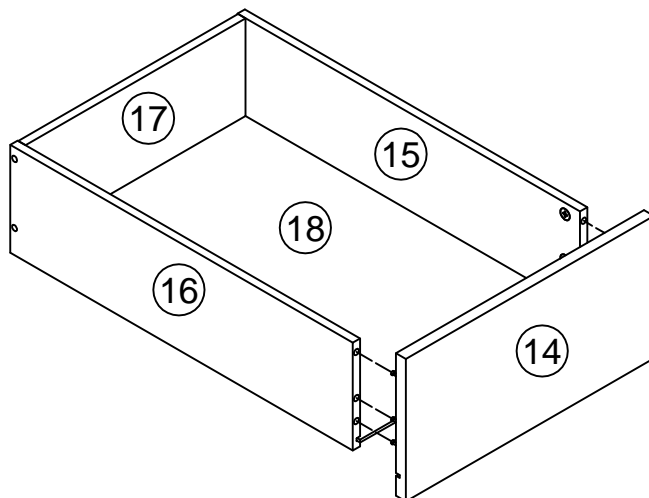

16 x3

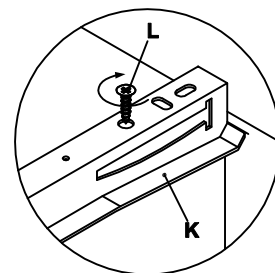
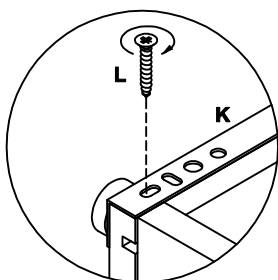
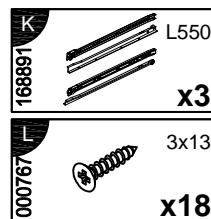
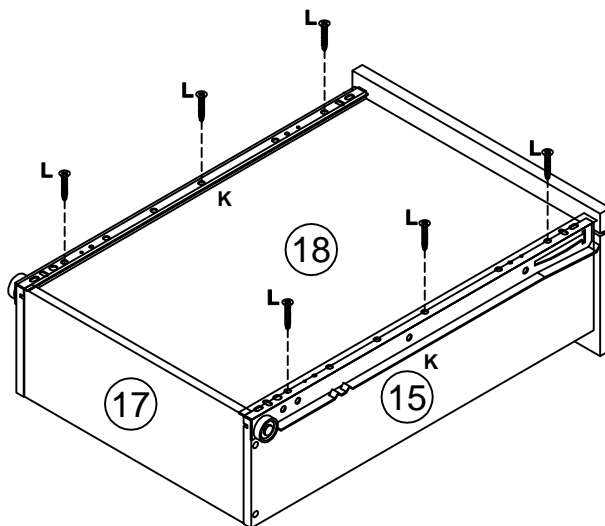

17

100640 Q 20x0.5
x5

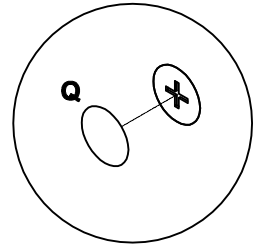
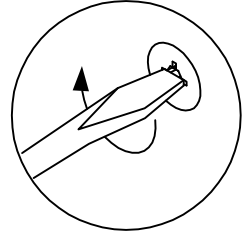
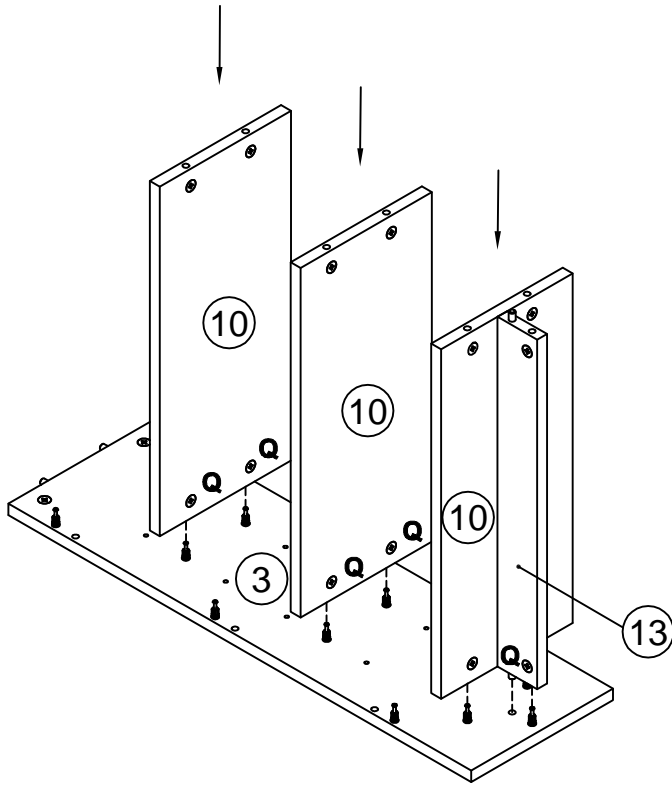

18

100640 Q 20x0.5
x3

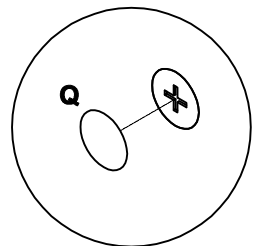
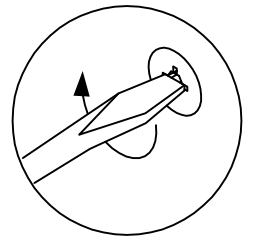
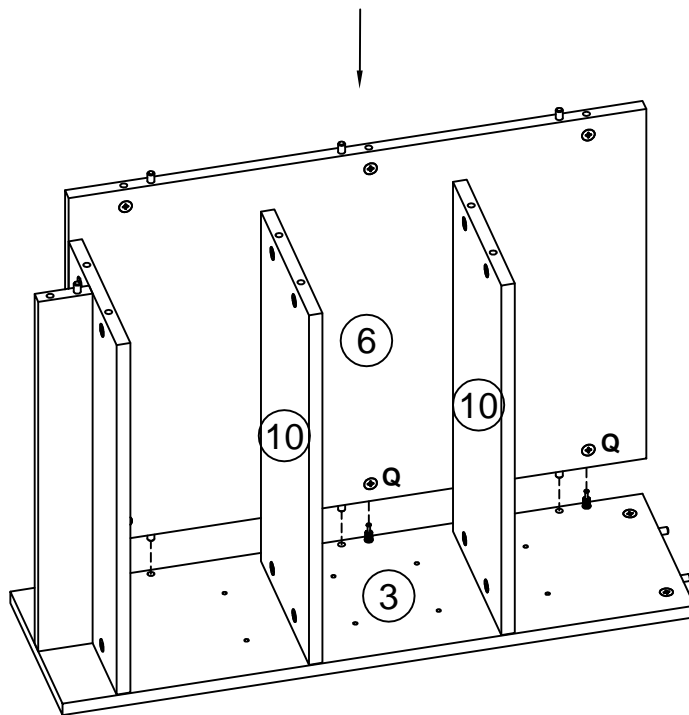

19

- P** 101777 70x50 **x2**
- D** 100640 20x0.5 **x8**

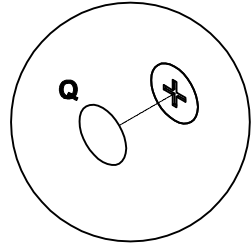
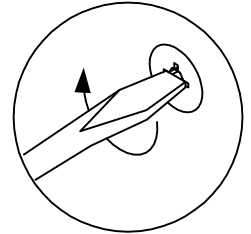
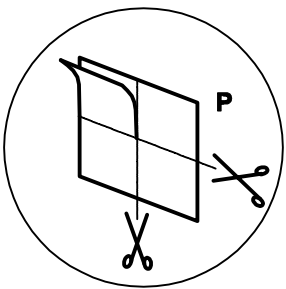
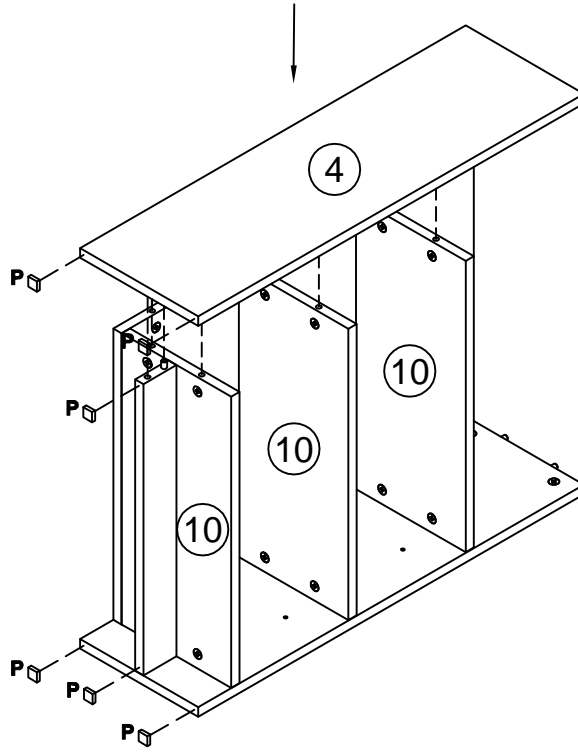

20

- D** 100640 20x0.5 **x4**

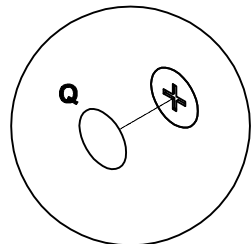
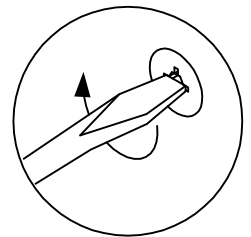
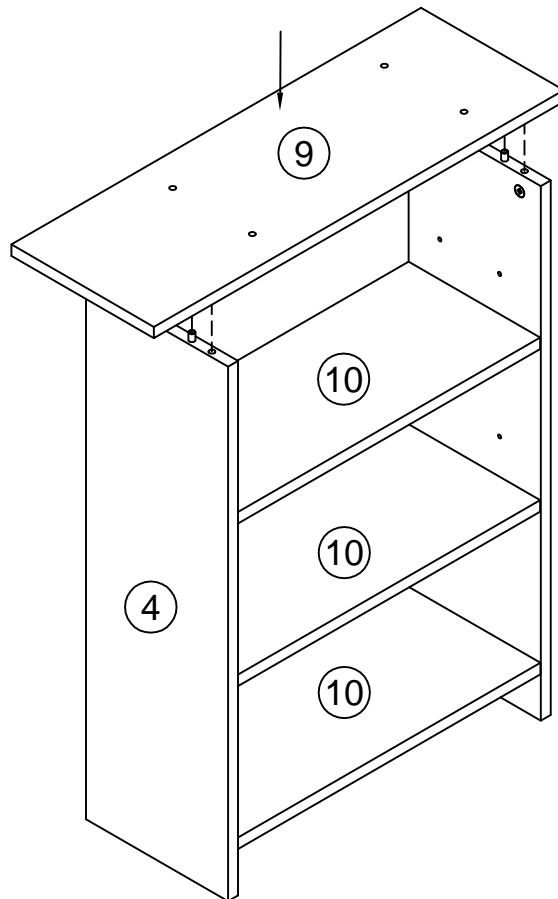

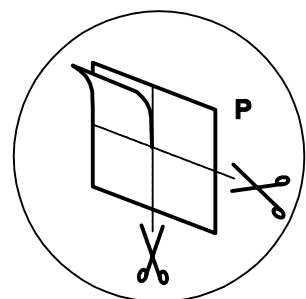
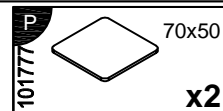
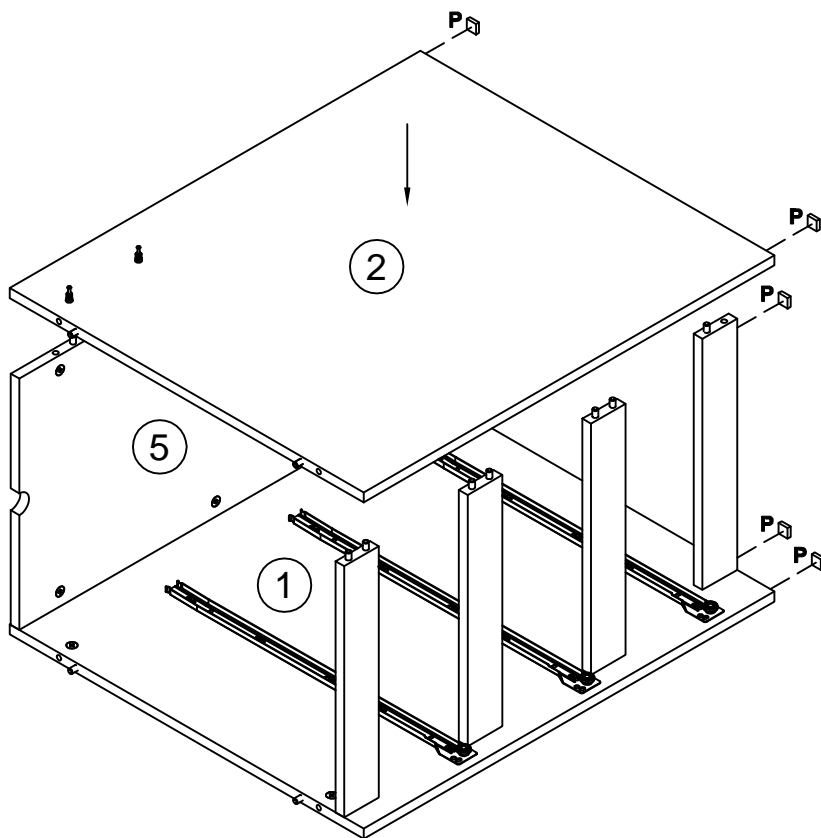
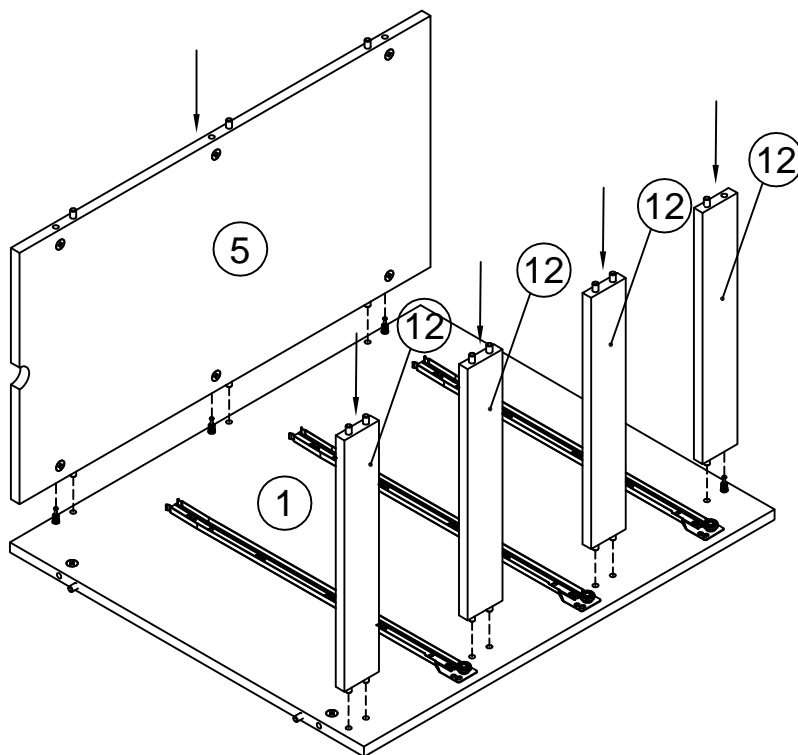

23

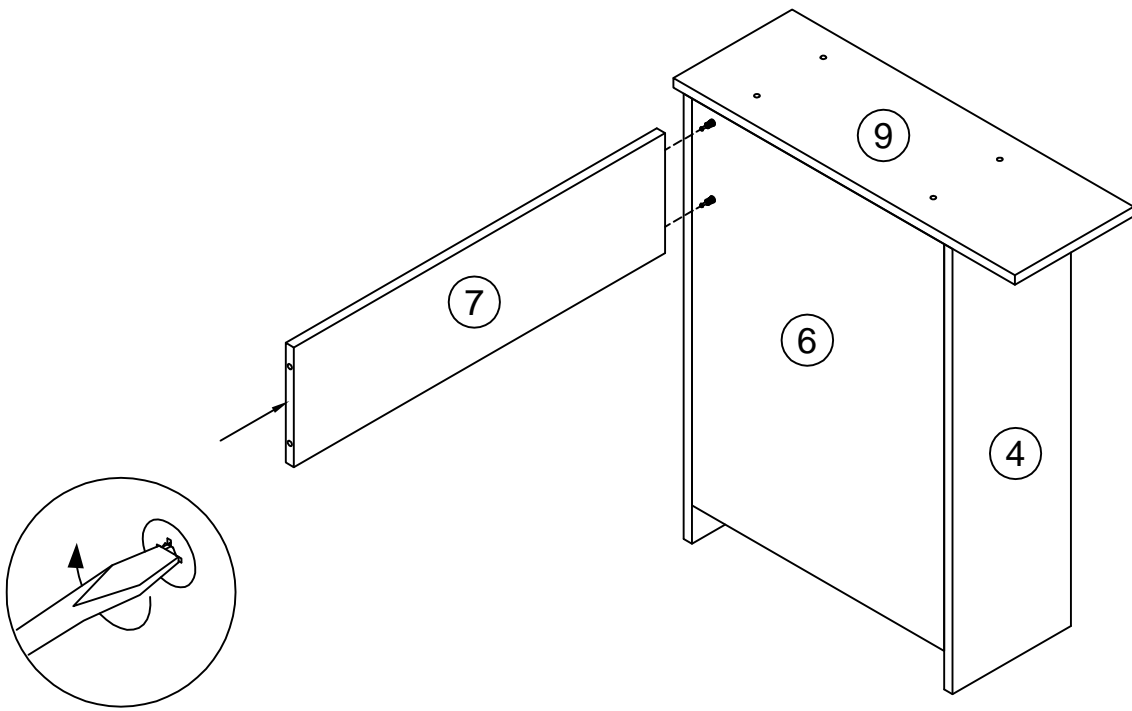

24

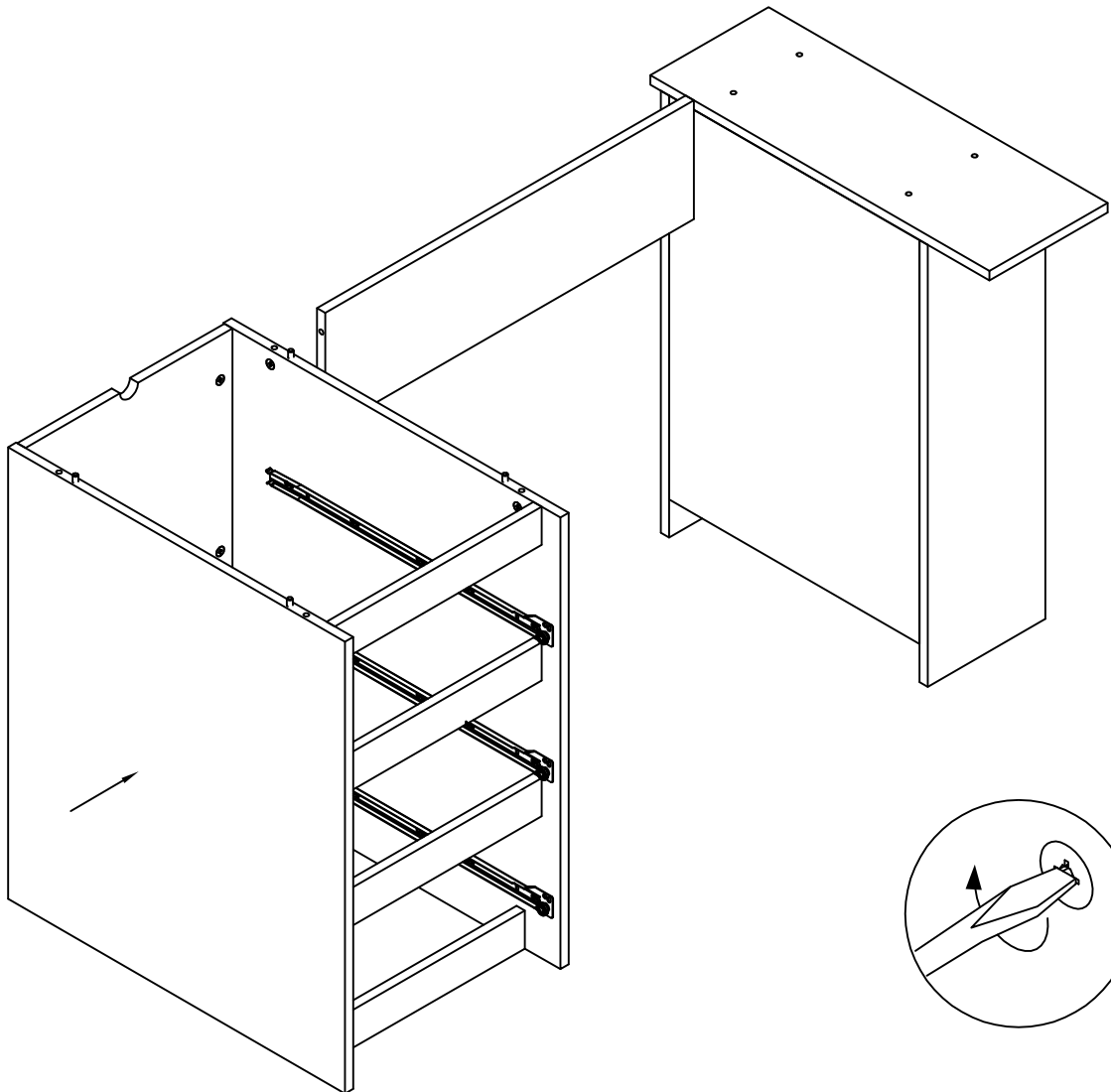

25

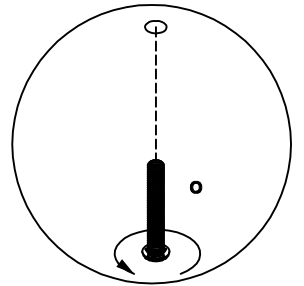
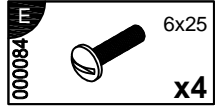
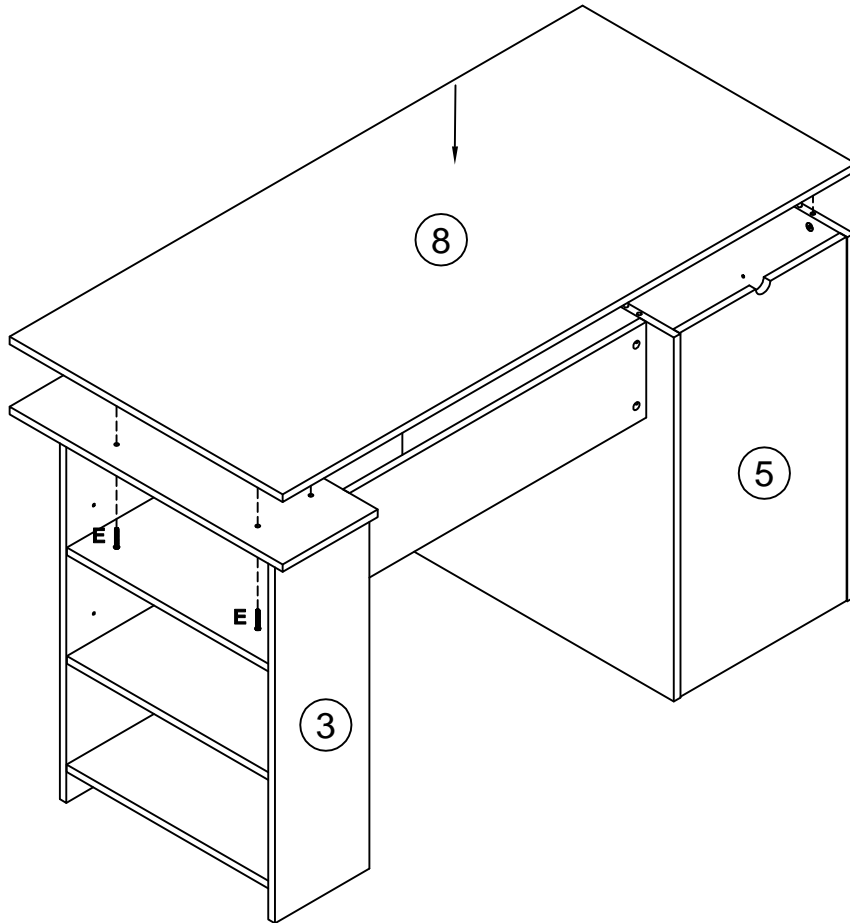

26

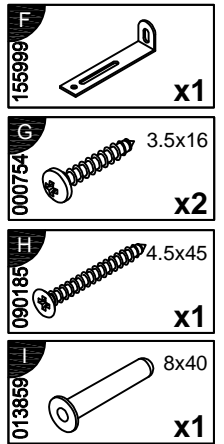
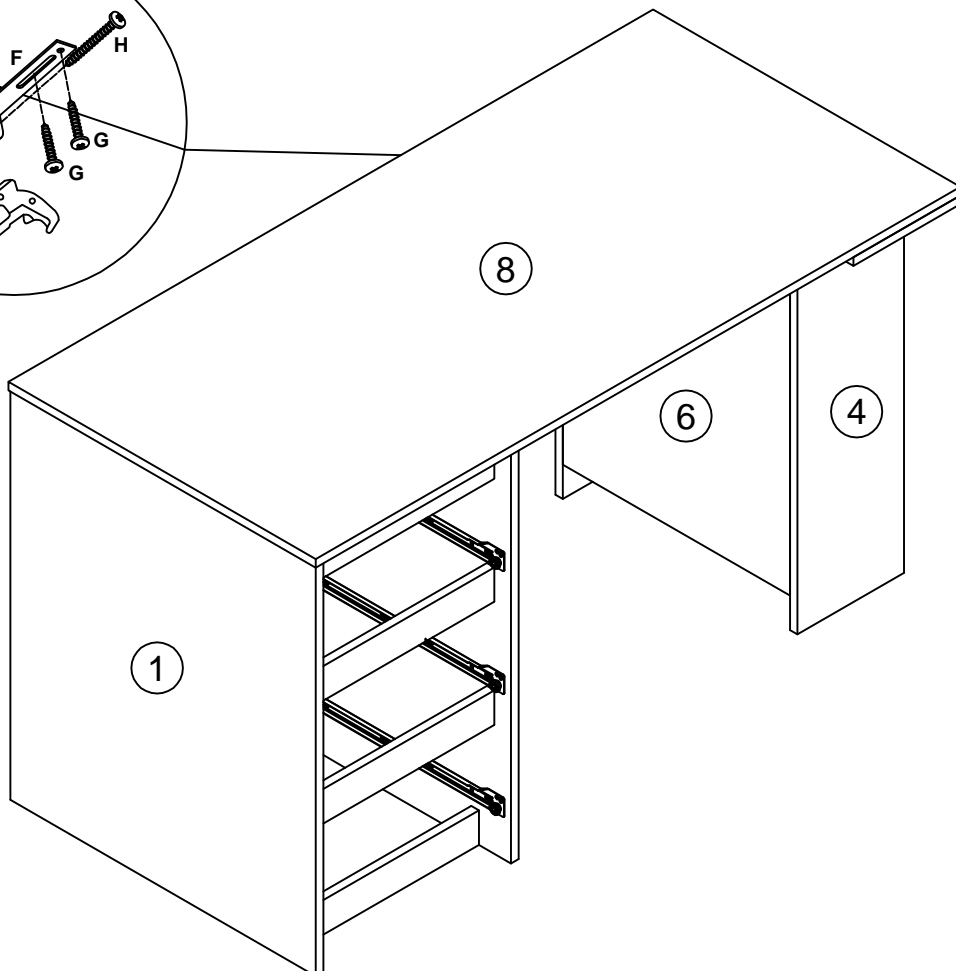
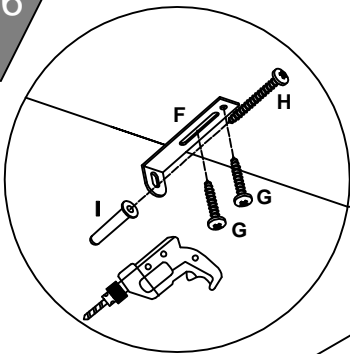

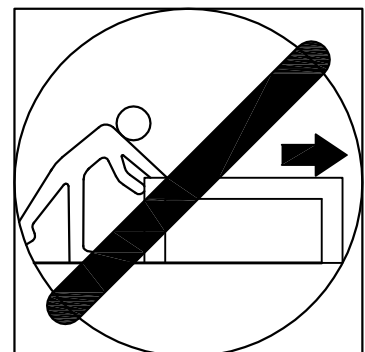
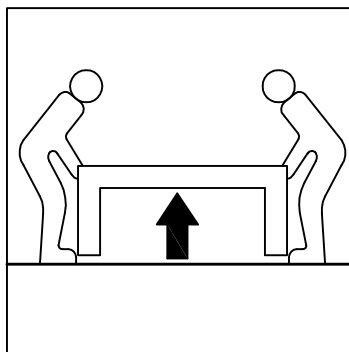
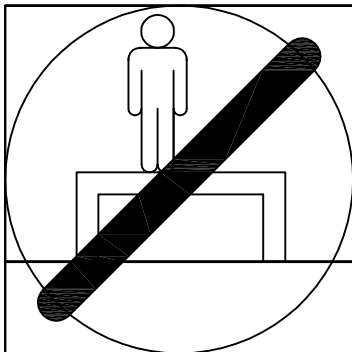
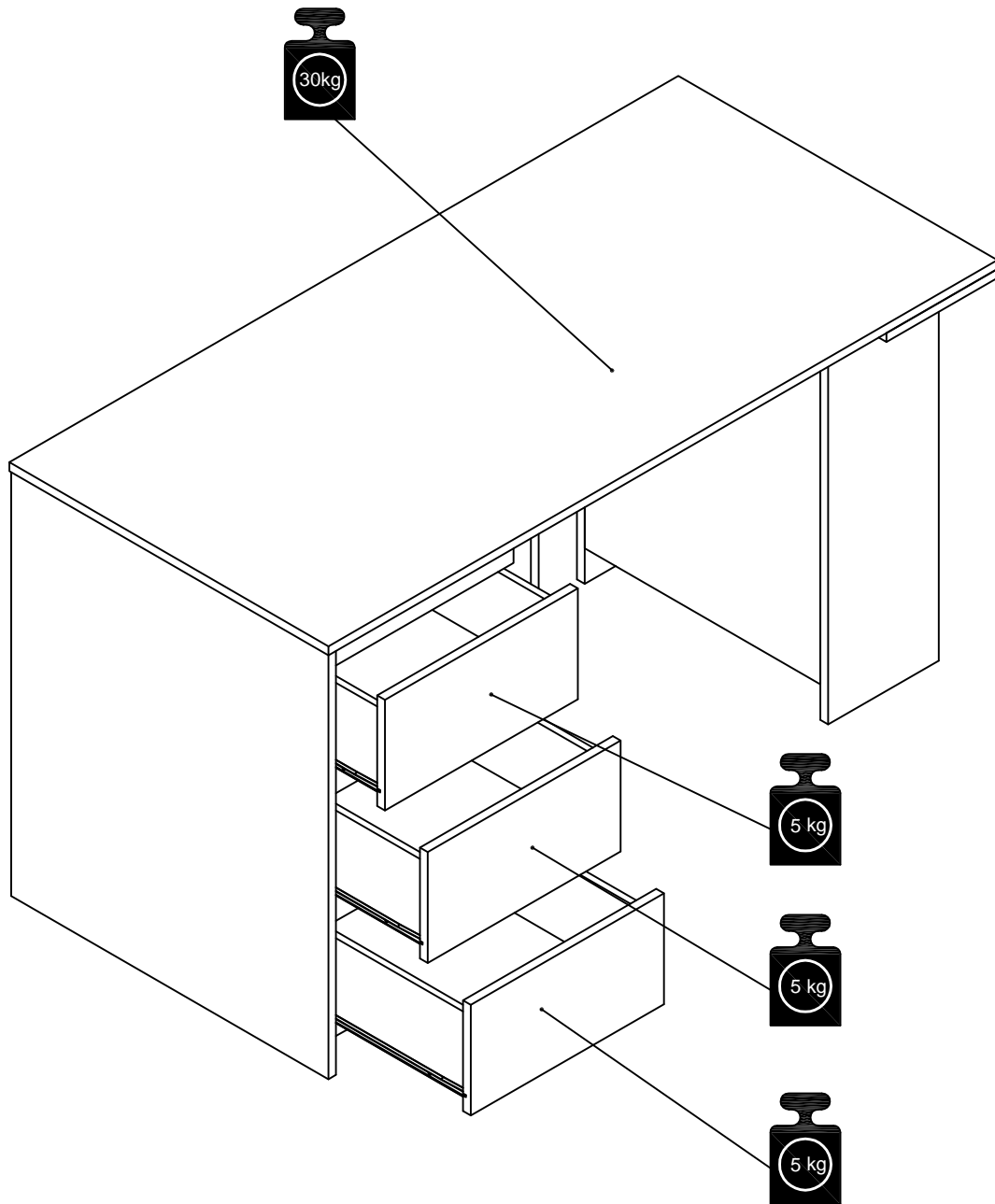

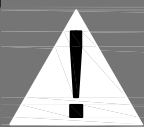

Achtung • Attention • Attenzione
Opgelet • Uwaga • Pozor • Figyelem
Atenție • Dikkat • Внимание

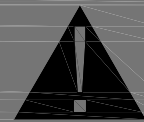

(D)	Wandbefestigung dient als Kippschutz – unbedingt anbringen! Bei einigen Wandtypen kann ein Spezialdübel erforderlich sein!
(GB)	The wall fastening serves to prevent tipping – be absolutely sure to mount it! For certain wall types, a special wall plug may be necessary!
(FR)	La fixation murale sert de protection contre le basculement – à installer impérativement ! Pour certains types de murs il faut des chevilles spéciales !
(IT)	Il fissaggio alla parete serve da protezione anti-ribaltamento – attaccarla assolutamente ! Per alcune strutture di parete può essere necessario un tassello speciale !
(NL)	Bevestiging aan de muur dient als kantelbescherming – zeker en vast bevestigen ! Bij enkele muurtypes is een speciale plug misschien vereist !
(PL)	Mocowanie do ściany jest jednocześnie zabezpieczeniem przed przewróceniem – koniecznie zamontować! Do niektórych rodzajów ścian koniecznie zastosować specjalne kołki mocujące.
(CZ)	Montáž na stěnu slouží jako ochrana proti převrnutí – bezpodmienečně umístěte! Uněkterých typů stěn může být zapotřebí speciální hmoždinka !
(SK)	Upevnenie na stenu slúži ako ochrana proti prevráteniu – bezpodmienečne použite! Pre niektoré druhy stien môže byť potrebná špeciálna hmoždenka !
(HU)	A terméket a falhoz kel rögzíteni, különben az felborulhat! Egyes fal típusoknál speciális tiplit kell használni !
(RO)	Sistemul de fixare la perete servește ca protecție la răsturnare – de montat obligatoriu! Pentru unele tipuri de pereți este posibil să fie necesar un diblu special !
(TR)	Duvardaki sabitleme, devrilmeye karşı bir emniyet tedbiridir ve mutlaka monte edilmelidir! Bazı duvar tiplerinde bunun için özel bir dübel gerekli olabilir !
(RU)	Обязательно установите крепление на стене во избежание опрокидывания ! Для некоторых типов стен может потребоваться специальный дюбель !