

1 → 2 → 3 ...

1 8x Nr.98	16x / 12x 6,3x12,5 Nr.451	8x / 6x 4x15 Nr.158
4x UC646-3D Nr.502		
2x UC646-3D Nr.523	4x UC646-3D 6,3x13 Nr.274	

Service-Hotline
01805-678101
0,14€ pro Minute
++49 für Österreich
Auslandstarif pro Minute
service@jaka-bkl.de
voor Nederland en België
00800-40119350
benelux@jaka-bkl.de

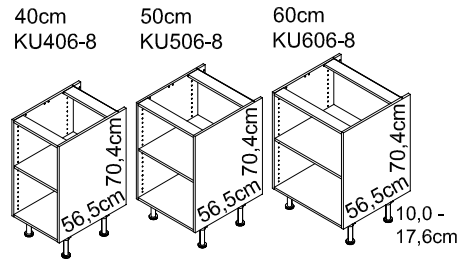

Montageanleitung

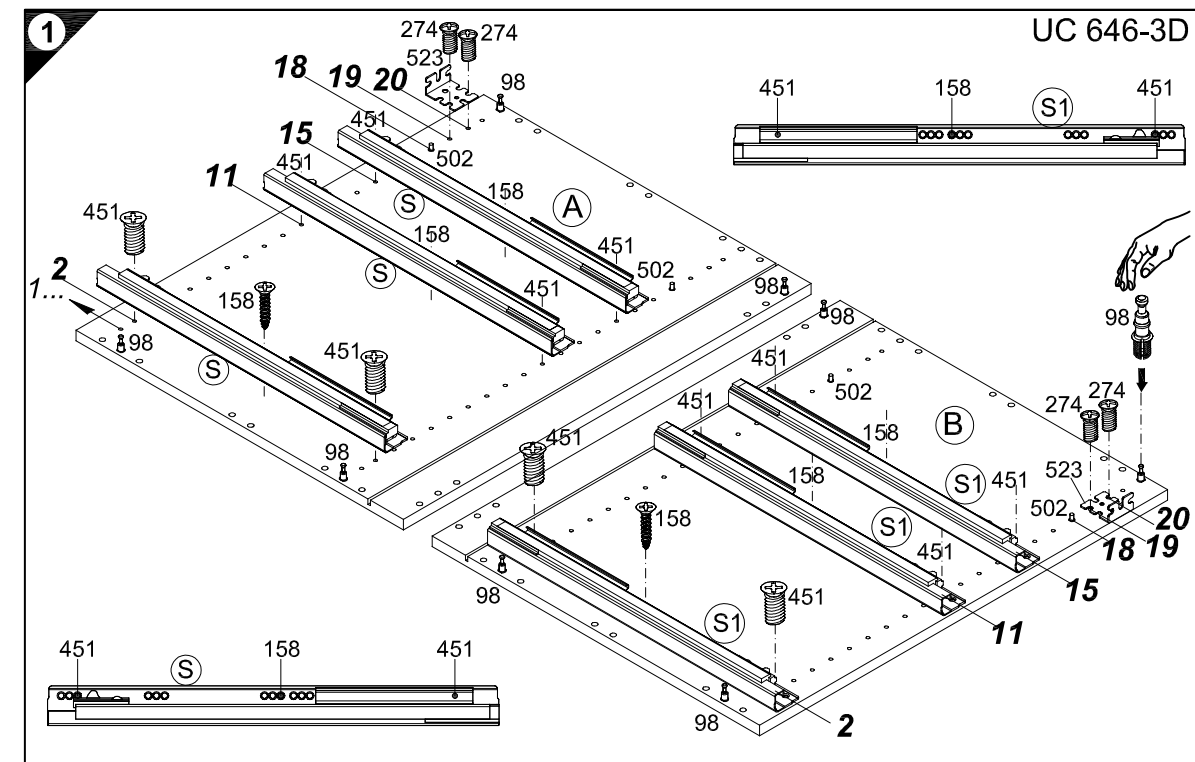
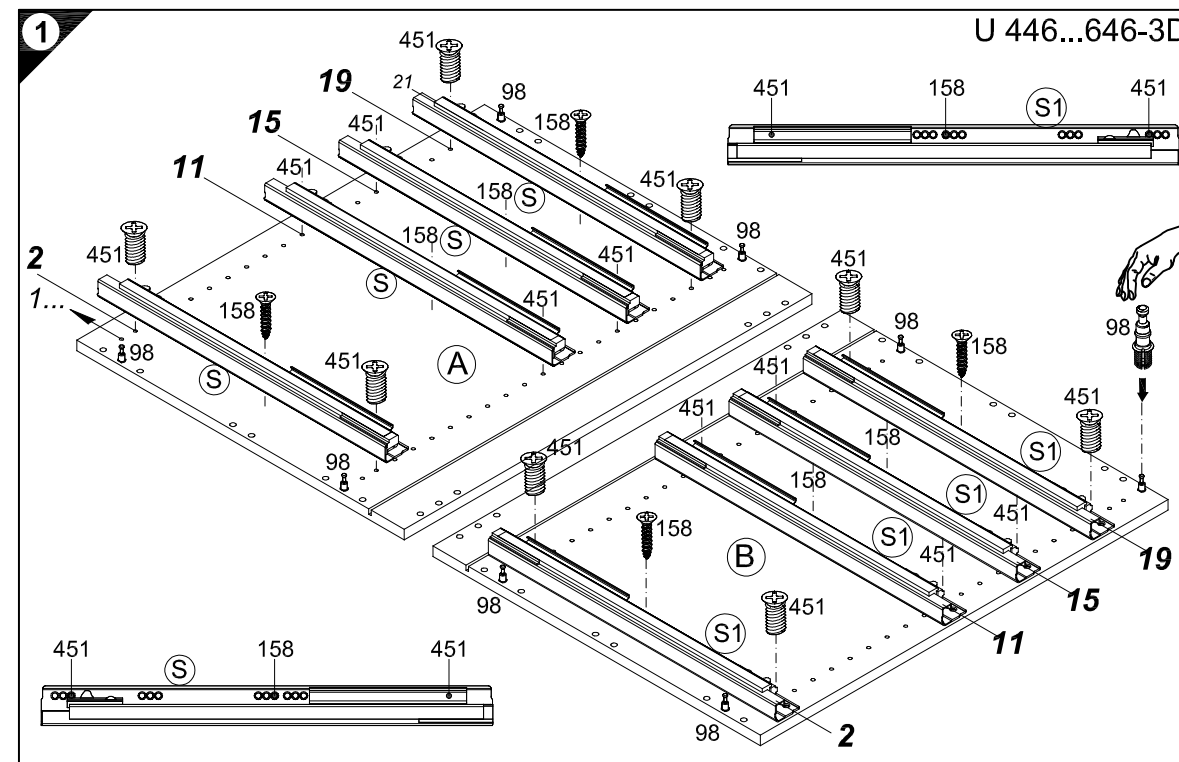
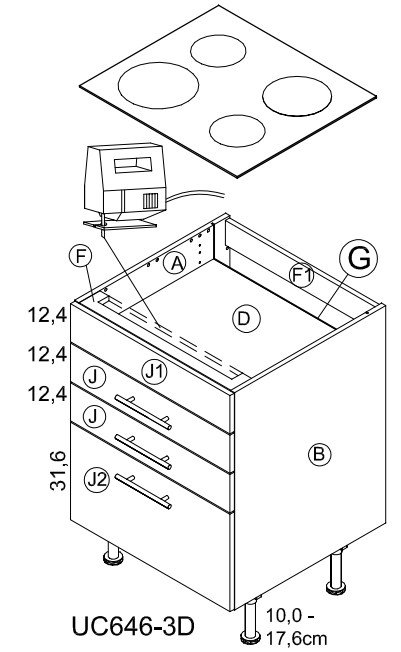
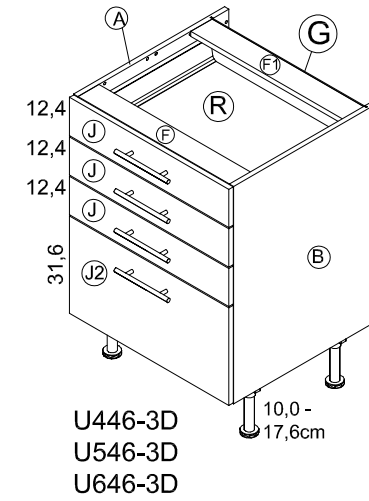
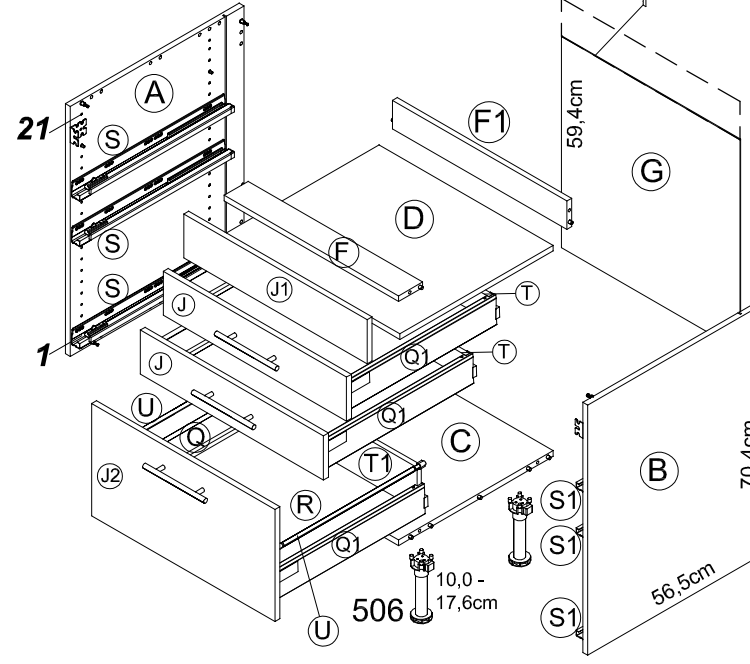
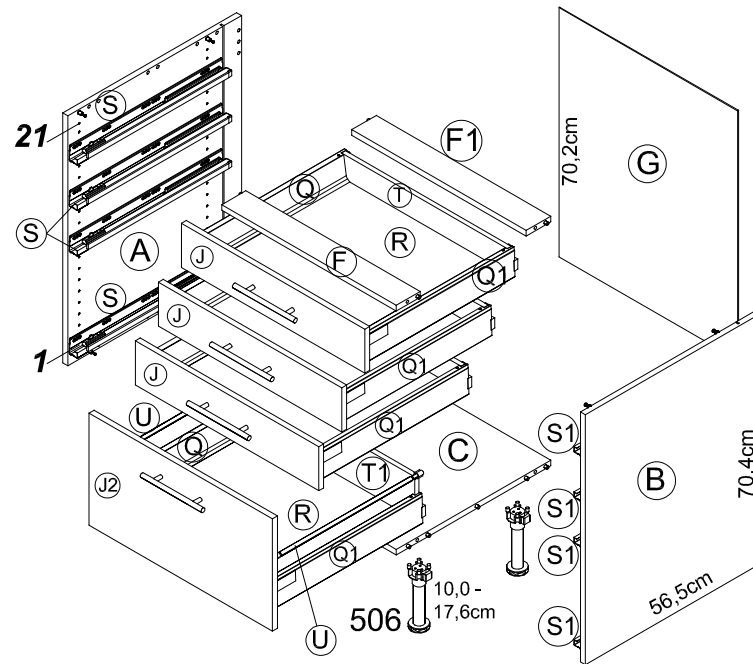

Ersatzteile/Spare parts/pièces de rechange/Reserveonderdelen/Piezas de recambio/Ricambi/Запасные части/Części zamienne/pótkatrészek/Náhradní části/Nadomestni deli/varaosat/reservdelar/náhradné diely/Utilizați piese de schimb/Yedek parçalar

40cm U 446-3D	(A)E941021 (B)E941021 (C)E951215 (F)E942975 (F1)E952975 (G)E970010 (J)E940564 (J2)E940643 (Q)E446918 (Q1)E446919 (R)E541902 (S)E446922 (S1)E446923 (T)E446931 (T1)E446941 (U)E446888
50cm U 546-3D	(A)E941021 (B)E941021 (C)E951224 (F)E942974 (F1)E952974 (G)E970117 (J)E940563 (J2)E940644 (Q)E446918 (Q1)E446919 (R)E541903 (S)E446922 (S1)E446923 (T)E446933 (T1)E446943 (U)E446888
60cm U 646-3D	(A)E941021 (B)E941021 (C)E951223 (F)E942973 (F1)E952973 (G)E970116 (J)E940562 (J2)E940645 (Q)E446918 (Q1)E446919 (R)E541904 (S)E446922 (S1)E446923 (T)E446934 (T1)E446944 (U)E446888
60cm UC 646-3D	(A)E941021 (B)E941021 (C)E951223 (D)E950303 (F)E942973 (F1)E952973 (G)E970116 (J)E940562 (J1)E940562 (J2)E940645 (Q)E446918 (Q1)E446919 (R)E541904 (S)E446922 (S1)E446923 (T1)E446944 (U)E446888

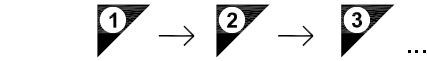

- 2** 8x Nr.76
- 2** 14x Ø8x30 Nr.80
- 2** 2x Nr.506
- 2** 4x 4x15 Nr.336
- 5** 16x Nr.204
- 8** 2x WS-8 4x15 Nr.336
- 9** 2x 4,5x30 Nr.417
- 9** 2x Nr.111
- 10** 1x Nr.505

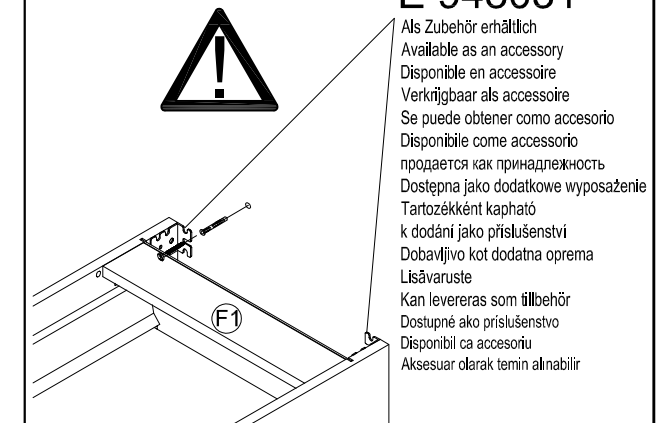
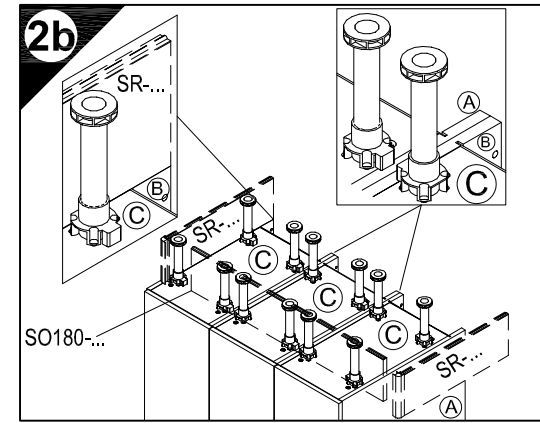
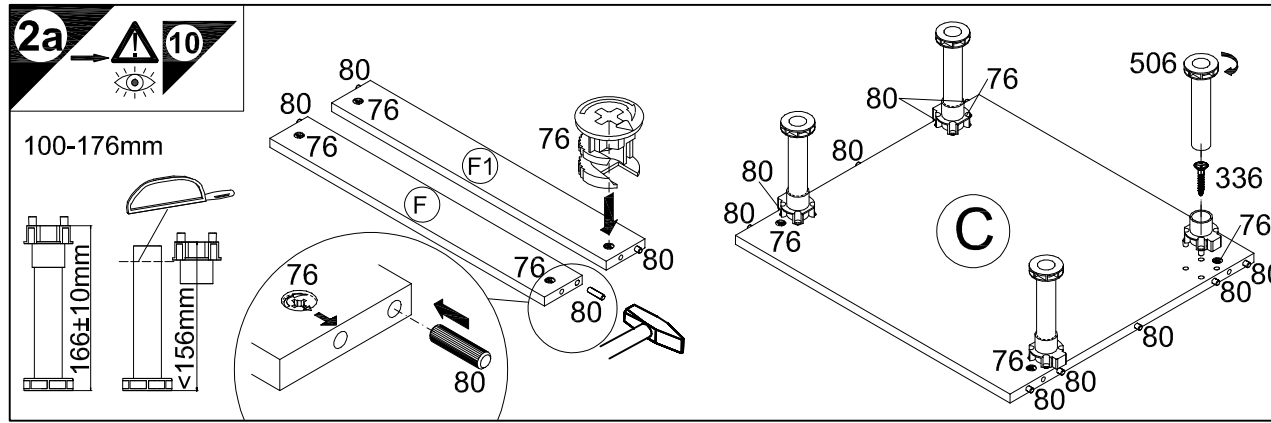

E 948031

Als Zubehör erhältlich
Available as an accessory
Disponibile en accessoire
Verkrijgbaar als accessoire
Se puede obtener como accesorio
Disponibile come accessorio
продаётся как принадлежность
Dostępna jako dodatkowe wyposażenie
Tartozékként kapható
k dodání jako příslušenství
Dobavljivo kot dodatna oprema
Lisävaruste
Kan levereras som tillbehör
Dostupné ako príslušenstvo
Disponibil ca accesoriu
Aksesuar olarak temin edilebilir

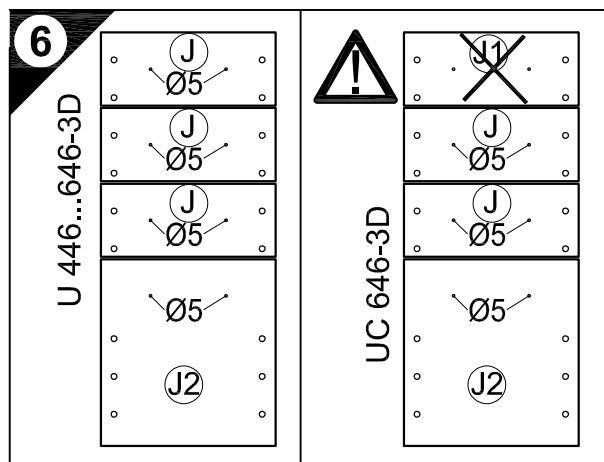
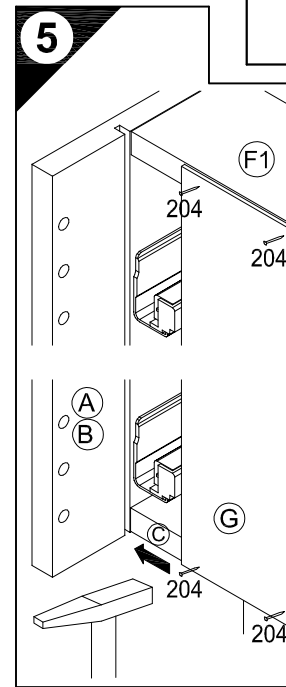
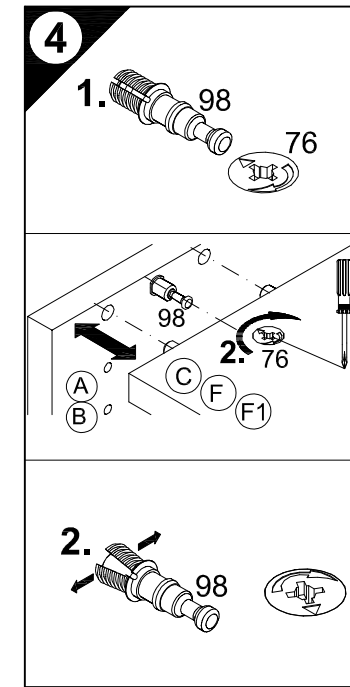
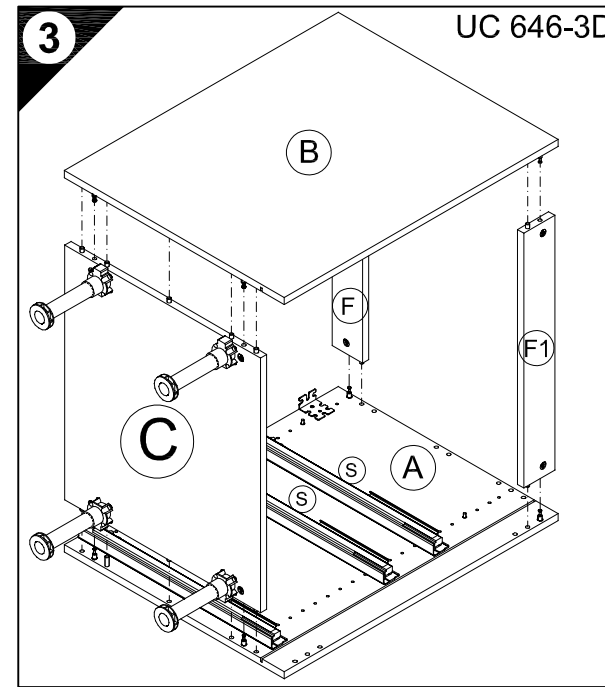
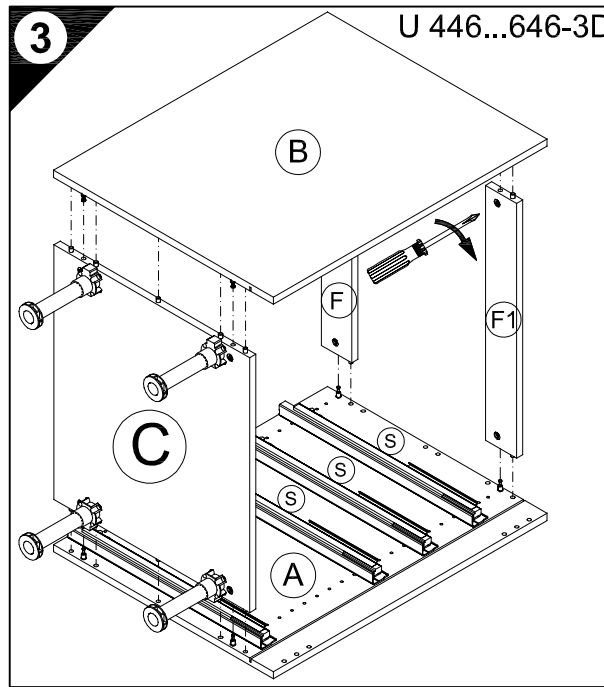

D Holzunterlage verwenden!
Front andrücken, scharfen Bohrer verwenden und mit wenig Druck durchbohren!
Use a wooden base!
Press front down, use sharp drill bit and, by applying slight pressure, drill a hole
F Utiliser un support en bois!
Appuyer sur la façade, utiliser un foret bien affûté et percer en appliquant une faible pression!
NL Houten onderlegger gebruiken!
Druk het front aan, gebruik een scherpe boor en oefen bij het boren weinig druk uit!
E ¡Utilizar una base de madera!
¡Presionar el frente, utilizar una broca afilada y taladrar con poca presión!
I Utilizzare una base di legno!
Appoggiare la facciata, utilizzare una punta di trapano affilata e trapanare esercitando solo una leggera pressione!
RUS Использовать деревянную подложку!
Прижать фасад, использовать острое сверло и просверлить с незначительным давлением!
PL Używać podkładkę z drewna!
Docisnąć front, użyć ostrego wiertła i przewiercić, używając małej siły nacisku!

H Alkalmazzon fa alátételt!
Nyomja le az előlapot, hasznájon éles fúró, és kis nyomással fúrja át!
CZ Použijte dřevěný podklad!
Přitlačte čelo, použijte ostrý vrták a provrtájte pomocí malého tlaku!
SLO Uporabite leseno podlago!
Pritisnite llnčno ter z ostrim svedrom in z majhnim pritiskom izvrtajte luknjo!
FIN Käytä puualustaa!
Palna etulevy palkolleen, käytä terävää poranterää ja poraa reikä vain kevyesti painamalla!
S Använd ett träunderlag!
Tryck fronten mot underlaget, använd vass borrh och borra lgenom med ett lätt tryck!
SK Použite drevený podklad!
Přitlačte front, použijte ostrý vrták a prevrtajte miernym tlakom!
RO suport de lemn!
Împingeți frontul, utilizați un burghiu ascuțit și perforați exercitând doar o presiune redusă!
TR Ahşap taban kullanın!
Önden bastırın, keskin matkap ucu kullanın ve az basınç uygulayarak delin!

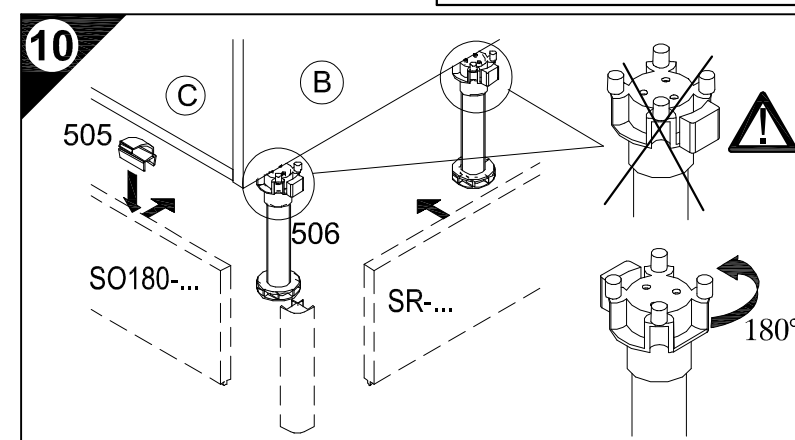
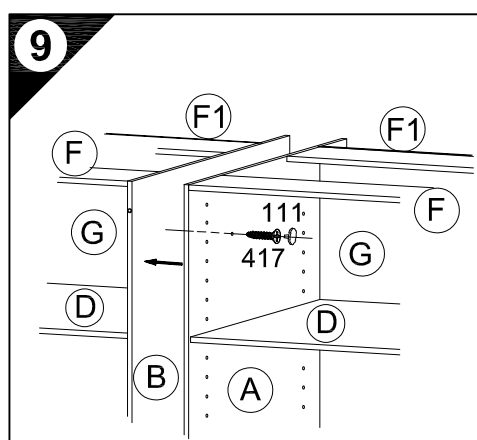
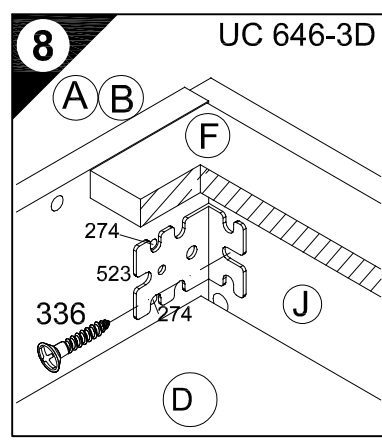
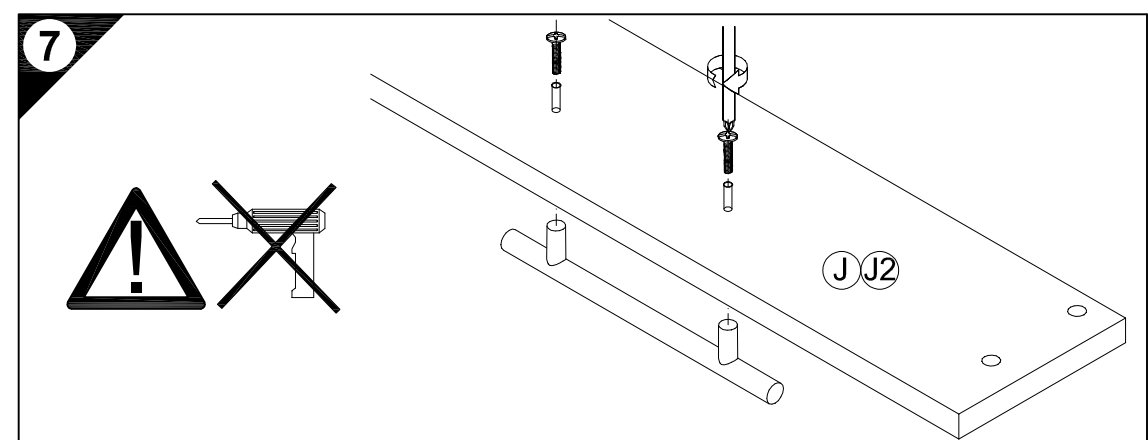
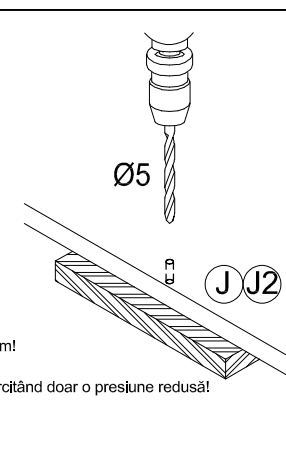

TANDEMBOX Schubkasten / Drawer / Tiroir / Lade

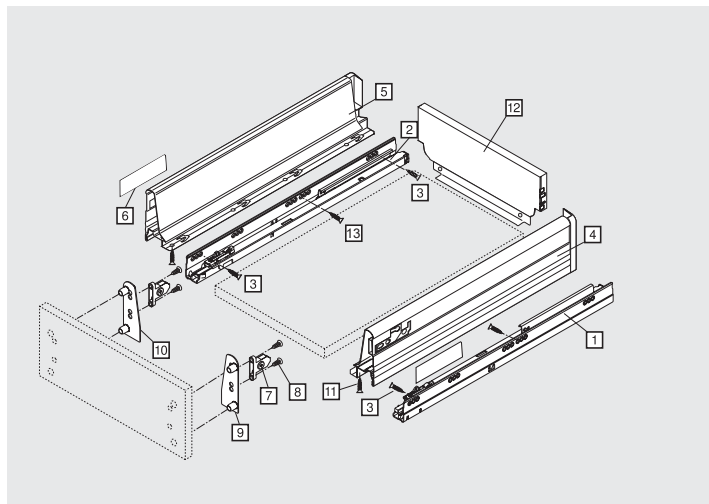

- 1 1x E446923
- 2 1x E446922
- 3 4x Nr. 451
- 4 1x E446919
- 5 1x E446918
- 6 2x Nr. 533
- 7 2x Nr. 526
- 8 4x Nr. 428
- 9 1x Nr. 521
- 10 1x Nr. 522
- 11 2x Nr. 157
- 12 1x E446...
- 13 2x Nr. 158

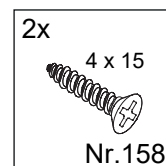
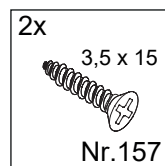
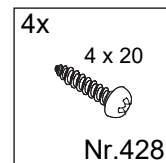
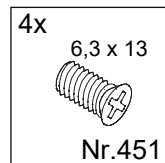

Montage / Assembly / Montage / Montage

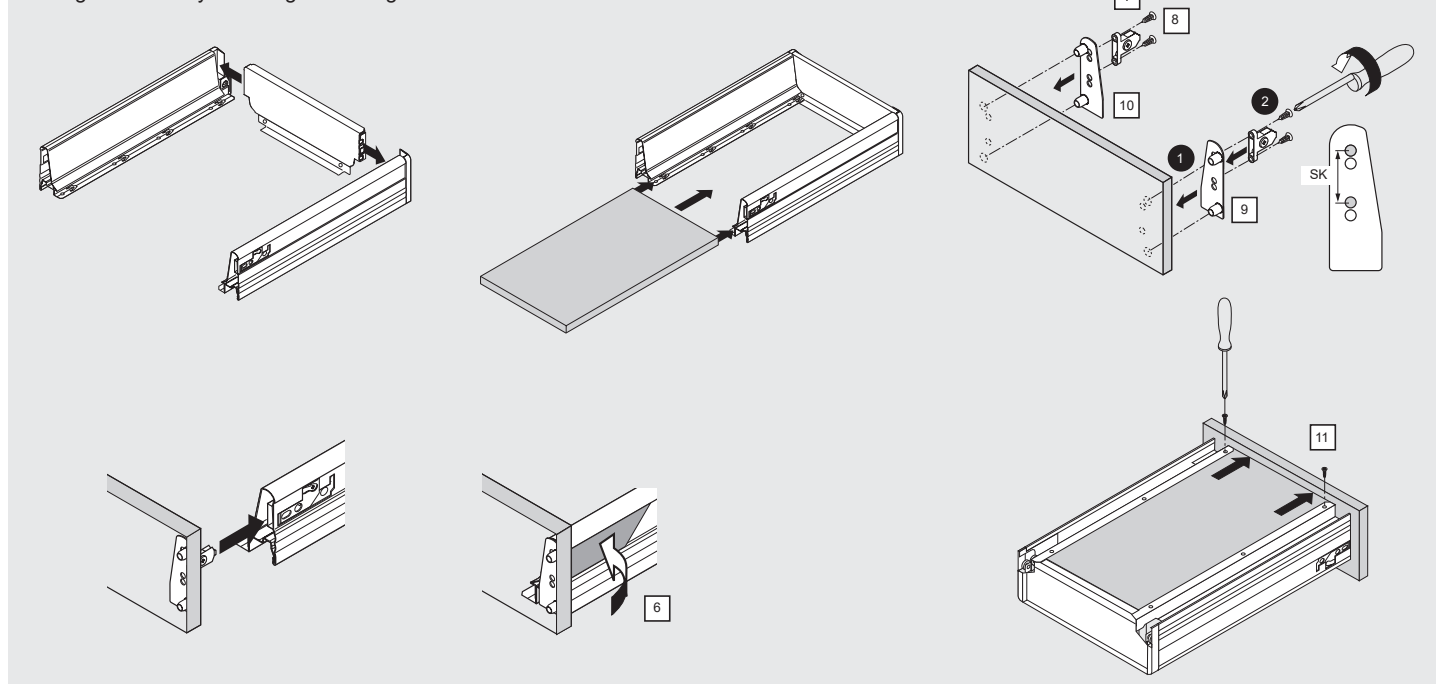

Demontage / Removal / Démontage / Demontage

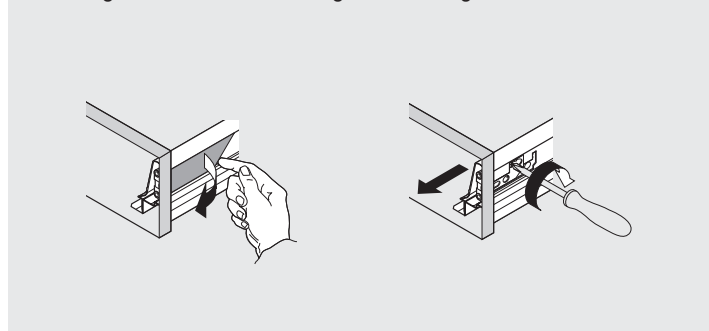

Höhenverstellung / Height adjustment / Réglage en hauteur / Hoogteverstelling

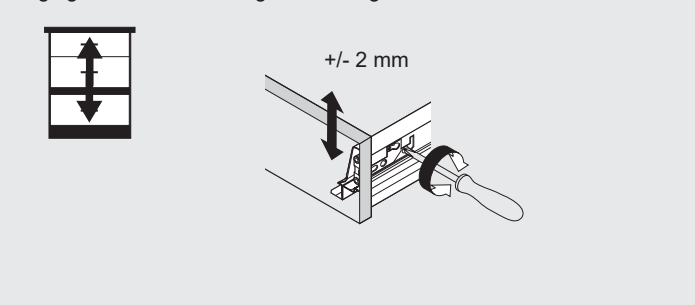

Seitenverstellung / Side adjustment / Réglage latéral / Zijdelingse verstelling

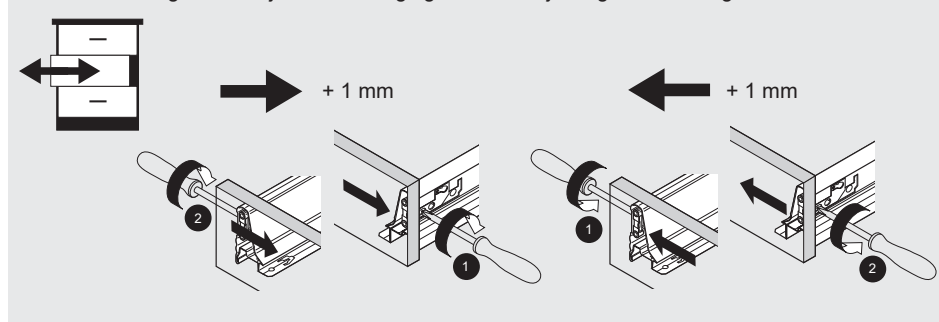

TANDEMBOX

Frontauszug / High frontende pull-out / Bloc tiroir / Voorraadlade

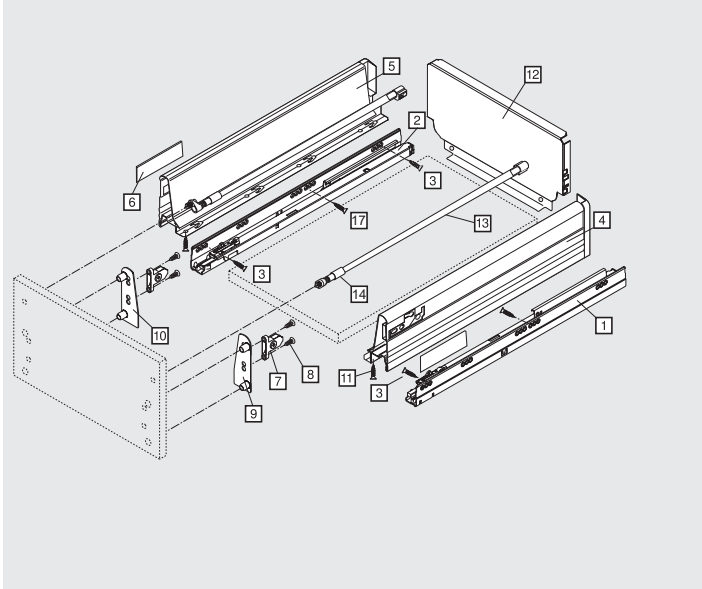

- 1 1x E446923
- 2 1x E446922
- 3 4x Nr. 451
- 4 1x E446919
- 5 1x E446918
- 6 2x Nr. 533
- 7 2x Nr. 526
- 8 4x Nr. 428
- 9 1x Nr. 521
- 10 1x Nr. 522
- 11 2x Nr. 157
- 12 1x E446...
- 13 2x E446885
- 14 2x Nr. 545
- 15 2x Nr. 544
- 16 2x Nr. 418
- 17 2x Nr. 158

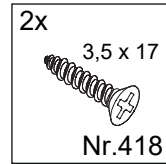
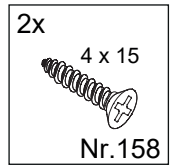
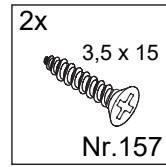
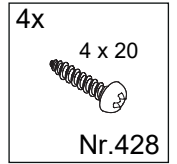
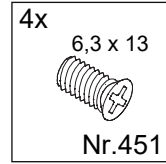

Montage / Assembly / Montage / Montage

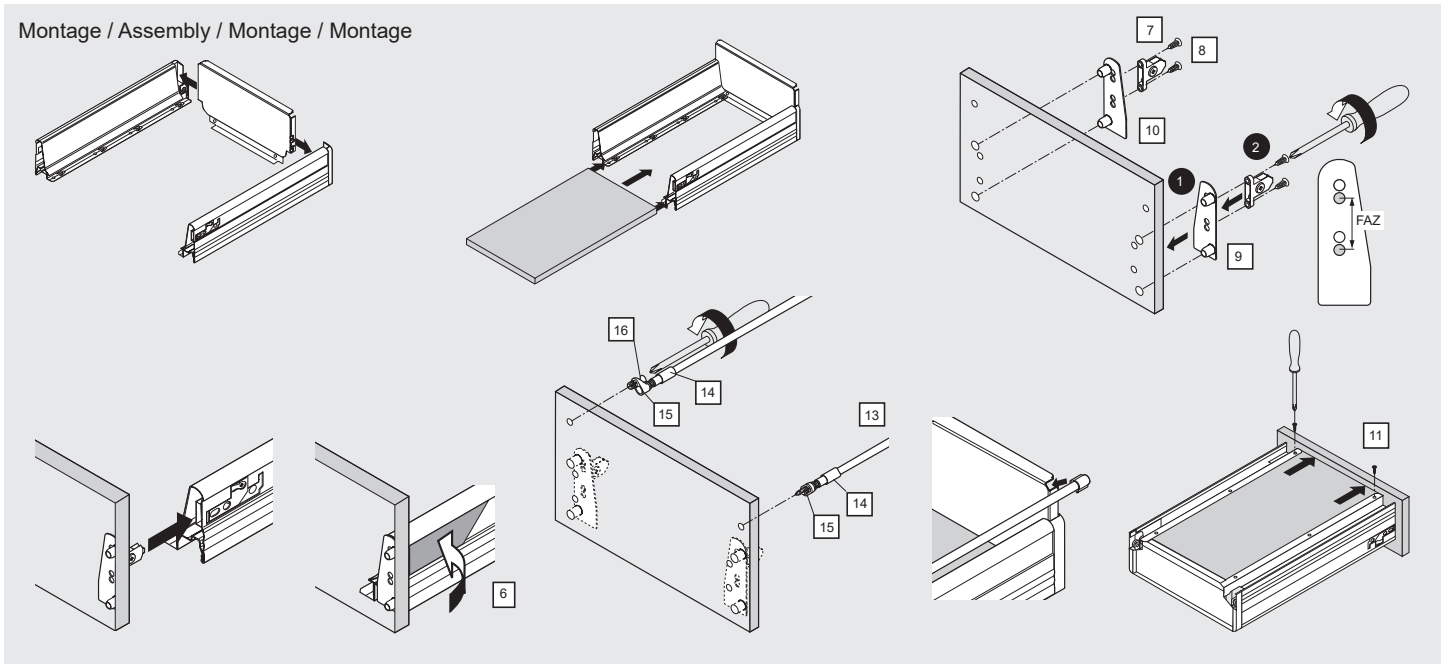

Demontage / Removal / Démontage / Demontage

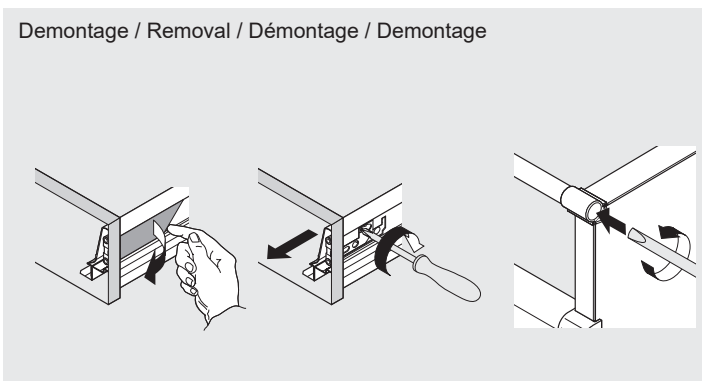

Höhenverstellung / Height adjustment / Réglage en hauteur / Hoogteverstelling

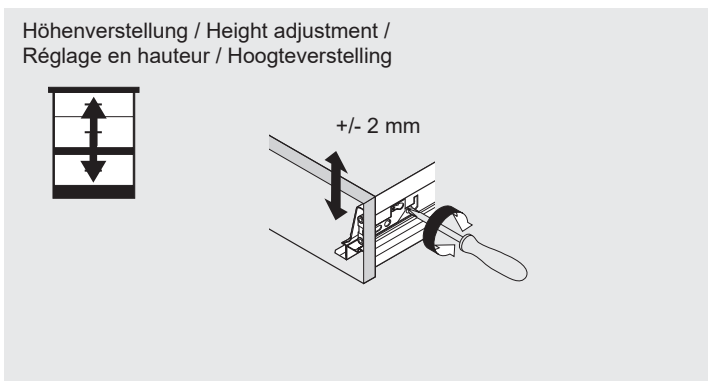

Seitenverstellung / Side adjustment / Réglage latéral / Zijdellingse verstelling

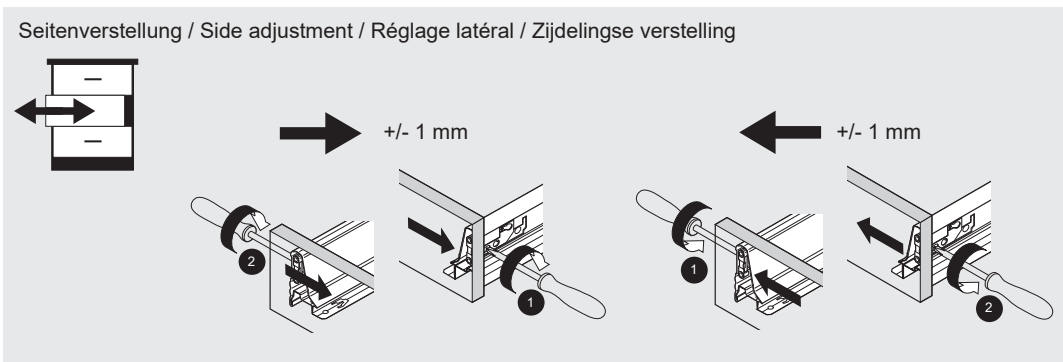

Neigung / Tilt adjustment / Inclinaison / Schuinite



SERVICEKARTE

VH

Liebe Kundin, lieber Kunde,

obwohl wir unsere Möbel vor der Auslieferung einer eingehenden Endkontrolle unterziehen, kann es vorkommen, dass einmal ein Zubehörteil fehlt oder während des Transports beschädigt wird. Senden sie den Artikel bitte nicht zurück, sondern fordern sie einfach Ersatz für das Einzelteil bei unserer Kundenhotline an. Die Telefonnummern finden sie auf den Serviceseiten im Katalog.

Bitte benennen sie die Teile wie sie auf ihrer Aufbauanleitung angegeben sind. Fügen sie auch **Artikelnummer, Modellnamen und Farbnummer** bei. **Siehe Beispiel.**

Wir werden ihre Anforderung sofort bearbeiten und ihnen das Ersatzteil umgehend zusenden.

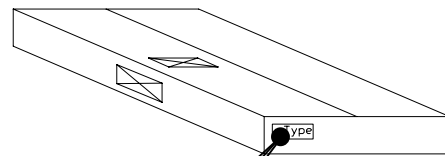

Muster - Bestellung		
Artikelnummer	123 456	
Modellname	Unterschrank VU634	
Farbe	TA 01	
Benötigte Ersatzteile:		
Bezeichnung	Nr.	Anzahl
Beschlagteil	98	2
Teil B	E 440 023	1

Bitte entnehmen sie die notwendige Ersatzteilnummer der Aufbauanleitung die zum Möbel gehört!

Kundendaten	
Kundennummer	
Name	
Vorname	
Strasse	
Haus-Nr.	
PLZ	
Ort	
Rechnungsdatum	
Tel. für Rückfragen	
Notizen:	

Ersatzteilbestellung		
Artikelnummer		
Modellname		
Farbe		
Benötigte Ersatzteile:		
Bezeichnung	Nr.	Anzahl
Grund der Ersatzteilanforderung:		