

LKZ: X0105

Modellname / Model name / Nom du modèle / Modellnamn  
 Nome modello / Název modelu / Modelnaam / Ime modela  
 Numéro Modelo / Modell neve / Название модели /  
 Názov modelu / Ime modela / Denumire model /  
 Наименование на модела / Nazwa modelu

**SNOW**

Modellnummer / Number / Numéro du modèle  
 Numero / Номер на модела / modello  
 Číslo modelu / Modell száma / Ěíslo modelu  
 Številka modela / Număr model / Broj modela  
 Modelnummer / Numer modelu

**X19 A9 711**

Type / Tipo / Típus / Typ / Тип / Tip

**711**

05.11.2021

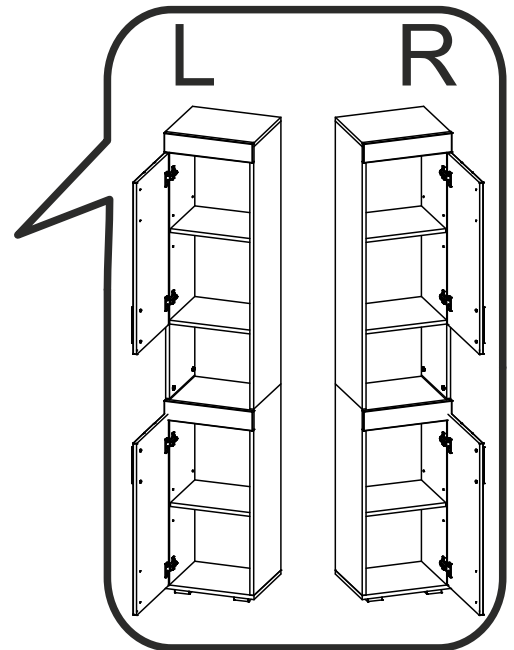
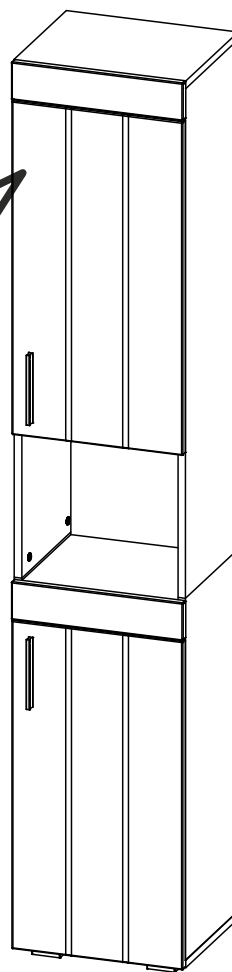
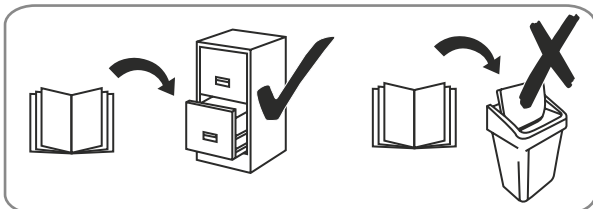
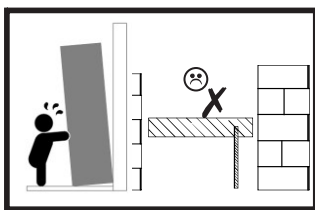
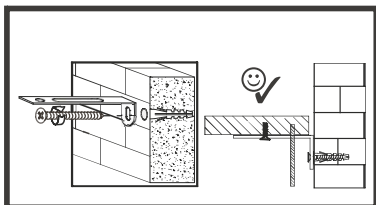
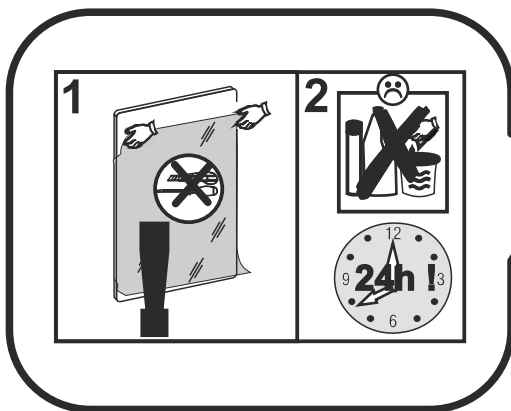
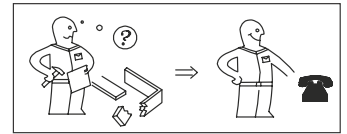
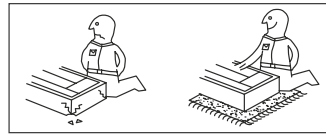
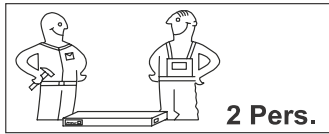
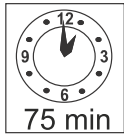

**Wichtig - Für spätere Verwendung  
 aufbewahren - sorgfältig lesen!**

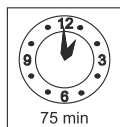
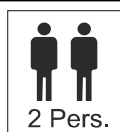
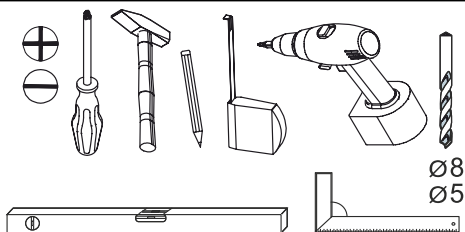

festziehen / tighten / Затягивать /  
 serrer / stringere / utiähnout / vasttrekken /  
 zategnuti / strângere / zwiázac / zacináč  
 szorosan meghúzni / pevne dotiahnut /  
 trdno pritegniti / затянуть / dra át



eindrücken / press in / enfoncez / wcisnąć  
 ribattere / zařlačit / Вкарайте / Indrukken  
 benyomni / silact' / vtisniti / tryck in  
 introducere prin apăsare / вдавить



ausmessen / measure / mesurer /  
 misurare / ometen / izmeriti / miara /  
 kimérni / izmeriti / măsurare / измерить  
 změřit / Измерете / mät upp / zmierzyc



drücken / press / presser / stisknout /  
 Натиснете / vtisniti / nasinac / drukken /  
 pritisnuti / nacisnac / pritisniti / нажать /  
 (meg)nyomni / apasare / tryck fast / nacisnac



einschlagen / hammer in / beverni / sla in  
 frapper au marteau / infossare / Zabit' /  
 zarazit / Набийте / zabiti / wbić  
 introduce prin bătaie / забить / zařlout



Drehen - wenden / przekreć - odwrócić /  
 Keren - omdraaien / Girare - Ruotare /  
 Okrenuti - ubnuti / Retourner - renverser /  
 Turn over - turn around / Otočte - obratite /  
 Zавърте - обърнете / Obrnite list /  
 Întoarceți - rotiți / Vrid runt - vänd /  
 прокрутить - повернуть / otočit - obrátit  
 elforgatni - megfordítani

LKZ: X0105

Modellname / Model name / Nom du modèle / Modellnamn  
Nome modello / Název modelu / Modelnaam / Ime modela  
Número Modelo / Modell neve / Название модели /  
Názov modelu / Ime modela / Denumire model /  
Наименование на модела / Nazwa modelu

**SNOW**

Modellnummer / Number / Numéro du modèle  
Numero / Номер на модели / modello  
Číslo modelu / Modell száma / Ěíslo modelu  
Številka modela / Numár model / Broj modela  
Modelnummer / Numer modelu

**X19 A9 711**

Type / Tipo / Típus / Typ / Тип / Tip

**711**

**D** Unser Direktservice für Beschlagteile  
Sollte Ihnen ein Beschlagteil fehlen, können Sie diese Servicekarte direkt an die untenstehende Adresse mailen. Wir können allerdings nur Beschlagteile auf diesem Wege verschicken. Sollten Sie eine andere Beanstandung an Ihrem Möbelstück haben, so wenden Sie sich bitte direkt an Ihr Möbelhaus.

**GB** Our direct order service for fitting  
If a fitting part is missing, you can e-mail this service card directly to the address below. However, we can only send fitting parts in this way. If you have any other cause for complaint concerning your item of furniture, please contact your furniture store directly.

**CZ** Naše přímé služby pro kování  
Chybí-li vám nějaký díl z kování, můžete tuto servisní kartu odeslat e-mailem přímo na níže uvedenou adresu. Touto cestou však můžeme rozesílat jen díly kování. Pokud byste reklamovali jiný díl nábytku, obraťte se přímo na svého prodejce nábytku.

**F** Bien étudier la notice de montage  
S'il vous manque une ferrure, veuillez envoyer directement la présente carte service à l'adresse e-mail indiquée ci-dessous. Cependant, ceci nous permet uniquement d'envoyer des ferrures. Pour tout autre type de réclamation concernant votre meuble, veuillez contacter directement votre magasin d'ameublement.

**I** Il nostro servizio diretto per l'ordine della ferramenta  
Qualora Vi dovesse mancare un pezzo di fissaggio, allora Vi preghiamo di inviare questa carta di servizio immediatamente all'indirizzo sottostante. Possiamo inviare i pezzi di fissaggio solamente per mezzo di questo procedimento. Qualora doveste avere qualche altra reclamazione in merito al mobile, allora Vi preghiamo di rivolgerVi direttamente al Vostro Negozio di mobili.

**BG** Нашата директна услуга за обков  
Ако липсват части от комплекта, ползвайте настоящата сервисна карта и ни я изпратете на e-mail адреса, посочен по-долу. По този начин можем да доставим само липсващи елементи от обкова. Ако установите други дефекти по мебелите, Ви съветваме да се обърнете към мебелната къща/магазин, от който сте закупили стоката.

**NL** Onze directservice voor losse onderdelen  
Wanneer er een onderdeel ontbreekt, kunt u deze servicekaart direct aan onderstaand e-mailadres sturen. Wij kunnen langs deze weg echter alleen beslagdelen versturen. Mocht u een ander probleem aan uw meubel hebben, verzoeken wij u contact op te nemen met uw meubeldealer.

**PL** Nasz bezpośredni serwis czeski montażowy  
Jeżeli brakuje części koniecznych do montażu, prosimy o przesłanie nam niniejszej karty serwisowej na niżej podany adres e-mailowy. W ten sposób możemy przesałać Państwu tylko brakujące części. W przypadku innych reklamacji dotyczących mebla, prosimy zgłosić się do salonu meblowego, w którym został dokonany zakup.

**HR** Servis za okove  
U slučaju da nedostaje neki od dijelova molimo vas da na dolje navedenu mail adresu pošaljete ovaj servisni obrazac. Na ovaj način mogu se dostaviti samo okovi. U slučaju da imate dodatne prigovore vezane uz komad namještaja molimo vas da se obratite izravno trgovini namještaja gdje je isti kupljen.

**HU** Direktszolgáltatunk vasalatók esetén  
Ha hiányzik egy vasalat, ezt a kártyát közvetlenül elküldheti az alább található címre. Azonban csakis vasalatókat tudunk így küldeni. Amennyiben másfajta reklamációt áll fenn bútorárbaját illetően, forduljon közvetlenül a bútorháznál.

**SK** Naš priamy servis pre časti kovania  
Ak by Vám chýbala nejaká časť kovania, môžete poslať túto servisnú kartu poslať e-mailom na nižšie uvedenú adresu. Diely kovania vieme poslať iba týmto spôsobom. Ak by ste mali inú reklamáciu ohľadom Vašho nábytku, obráťte sa priamo na Vašu predajňu nábytku.

**SLO** Naše direktno uslužne storitve za okovje  
Če vam manjka kakšno okovje, lahko to servisno kartico pošljete po e-pošti direktno na spodnji naslov. Po tej poti vam lahko pošljemo samo okovje. Če želite reklamirati kakšen drug del pohištva, se obrnite neposredno na vašo trgovino pohištva.

**RO** Service-ul nostru direct pentru feronerie  
În cazul în care vă lipsește o piesă de feronerie puteți să trimiteți direct acest card de service prin e-mail la adresa de mai jos. Noi nu putem expedia piese de feronerie decât pe această cale. Dacă aveți o altă reclamație referitoare la piesa de mobilier, atunci vă rugăm să vă adresați direct la magazinul dvs. de mobilă.

**RUS** Наш прямой сервис для поставок фурнитуры  
Если окажется, что Вам не хватает того или иного элемента фурнитуры, Вы можете отправить сервисную карту по факсу непосредственно на нижеприведенный адрес электронной почты. Однако, таким образом мы можем пересылать лишь фурнитуру. Если же у Вас возникнут иные претензии относительно приобретенной мебели, пожалуйста, обращайтесь непосредственно в организацию, осуществившую продажу.

**S** Vår direktservice för beslagsdelar  
Om du saknar en beslagsdel kan du skicka detta servicekort direkt till e-postadressen som anges nedan. Tänk på att detta är den enda möjligheten att skicka beslagsdelar till dig. Om du vill reklamera din möbel av en annan anledning måste du kontakta ditt möbelfhus direkt.

**ES** Nuestro servicio directo para accesorios  
Si le falta algún accesorio, puede enviar esta tarjeta de servicio directamente a la siguiente dirección. No obstante, por este método solo podemos enviar accesorios. Si tiene alguna otra objeción sobre su mueble, consulte directamente con su mueblería.

**TR** Donatılar için doğrudan servisimiz  
Bir donatınız eksikse bu servis kartını doğrudan aşağıda bulunan adrese doğrudan mail yazabilirsiniz. Sadece bu yolla donatılar gönderiliriz. Mobilyanızda başka şikayetleriniz varsa lütfen doğrudan mobilya satıcınıza danışın.

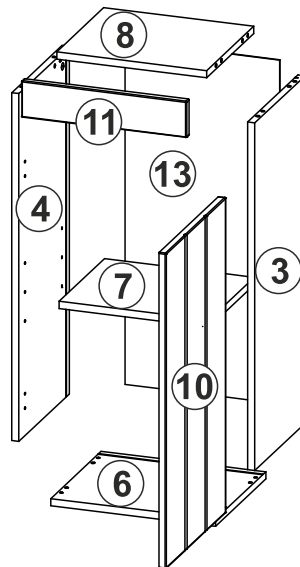
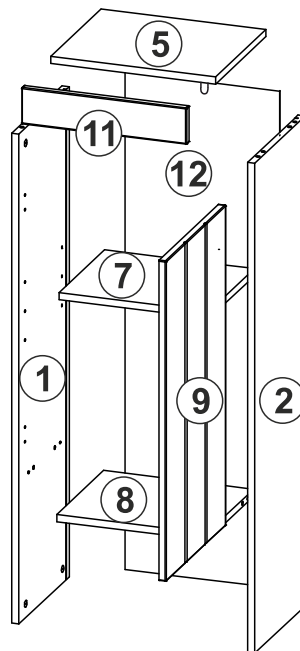
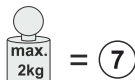
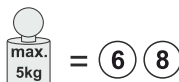

Nr.	Maße mm			Colli	Anzahl
1	1081	305	16	1/1	1
2	1081	305	16	1/1	1
3	767	305	16	1/1	1
4	767	305	16	1/1	1
5	364	305,5	16	1/1	1
6	364	305,5	16	1/1	1
7	331	275	16	1/1	2
8	331	284,5	16	1/1	2
9	707	362	16	1/1	1
10	696	362	16	1/1	1
11	364	80	16	1/1	2
12	1098	341	2,5	1/1	1
13	758	341	2,5	1/1	1
B1				1/1	1

Grund der Beanstandung / Reason of the objection:

Möbelhaus / Furniture store:

Name / Name: Telefon / Telephone:

PLZ / postal code: Ort / City:

Strasse / Street:

Haus-Nr. / House No.: @E-Mail:

E-Mail Kundenservice / Customer service e-mail / E-mail servisního střediska / E-mail de notre service clientèle / e-mail servizio clienti / E-mail на отдела за обслужване на клиенти / E-mail klantenservice / E-mail servisu dla klientów / Servisna mail adresa / Az ügyfélszolgálat e-mail címe / E-mail zákaznického servisu / E-pošta Servisna služba / E-mail Serviciu clienți / E-Mail сервисной службы / E-postadress kundservice / Servicio de atención por correo electrónico / Müşteri hizmetleri e-postası

service@xonox-home.com  
Hotline xonox.home GmBH  
0049-(0)5261-9202800

LKZ: X0105

Modellname / Model name / Nom du modèle / Modellnamn  
Nome modello / Název modelu / Modelnaam / Ime modela  
Número Modelo / Modell neve / Название модели /  
Názov modelu / Ime modela / Denumire model /  
Наименование на модела / Nazwa modelu

**SNOW**

















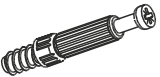
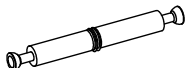

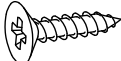
Modellnummer / Number / Numéro du modèle  
Numero / Номер на модела / modello  
Číslo modelu / Modell száma / Ěíslo modelu  
Številka modela / Numár model / Broj modela  
Modelnummer / Numer modelu

**X19 A9 711**

Type / Tipo / Típus / Тип / Тип / Tip

**711**

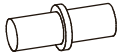
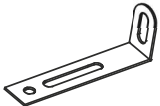
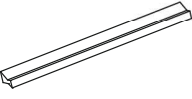
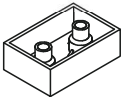
## B1

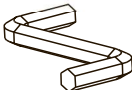
<p>Ø8x30</p>  <p><b>A0 x16</b></p>	<p>Ø8x50</p>  <p><b>A1 x4</b></p>	 <p><b>B0 x4</b></p>	<p>6,4x50</p>  <p><b>B1 x4</b></p>	<p>Ø5</p>  <p><b>B54 x12</b></p>	 <p><b>C01 x20</b></p>
 <p><b>C1 x20</b></p>	 <p><b>C2 x12</b></p>	<p>L-68</p>  <p><b>C3 x4</b></p>	<p>3x15</p>  <p><b>D0 x16</b></p>	<p>4x16</p>  <p><b>D10 x8</b></p>	<p>4x20</p>  <p><b>D14 x8</b></p>
<p>3,5x16</p>  <p><b>D17 x20</b></p>	<p>5x70mm</p>  <p><b>E2 x1</b></p> <p>8x50mm</p> 	 <p><b>F0 x16</b></p>	 <p><b>F1 x4</b></p>	 <p><b>G1A x4</b></p>	 <p><b>G1B x4</b></p>
 <p><b>H0 x8</b></p>	 <p><b>I1 x1</b></p>	 <p><b>L30 x2</b></p>	 <p><b>T1 x4</b></p>	 <p><b>U0 x4</b></p>	 <p><b>Z x1</b></p>

**(D) Sehr geehrter Kunde,**

als Möbelproduzent möchten wir Sie darüber informieren, dass eine Befestigung nur so gut ist wie die Verbindung zwischen Befestigungsmaterial (Dübel) und Mauerwerk. Prüfen Sie bei Hängeelementen Ihr Mauerwerk und verwenden Sie nur dafür vorgesehene Dübel aus einem Fachmarkt. Letztendlich ist der Monteur für die Befestigung am Mauerwerk verantwortlich.

Die Montage und das Verlegen der Elektroartikel sind nur von autorisiertem Fachpersonal durchzuführen. Beachten Sie die Beschreibungen und die Gewichtsangaben in der Montageanleitung.

Halten Sie bitte die angegebenen max. Gewichtsangaben ein. Bei Überlastungen, die durch spielende Kinder, Menschen, Material oder sonstige Einwirkungen entstehen -übernehmen wir als Möbelproduzent keine Haftung!

Die einwandfreie Funktion des Möbels ist nur bei lot- und waagerechter Aufstellung gewährleistet. Die Türen sind vorjustiert, müssen aber ggf. aufgrund örtlicher Bedingungen neu ausgerichtet / eingestellt werden!

Alle elektrischen Installationen sind nach den gültigen Normen bzw. Vorschriften von VDE, CE, MM gefertigt. Die zu verwendende Leuchtmittelstärke ist auf der jeweiligen Lampenfassung angegeben.

Bei Nichteinhaltung der max. Wattzahl besteht durch Überhitzung Brandgefahr. Das Zudecken der Leuchtmittel ist wegen Brandgefahr zu unterlassen!

Alle Schrauben sowie tragende Verbindungsstelle sollten nach 5 bis 6 Wochen nachgezogen werden, um eine dauerhafte Standsicherheit zu gewährleisten!

**Keine scheuernden Putzmittel verwenden!**

Werden Betriebs-, Bedienungs- oder Montageanweisungen nicht befolgt, Änderungen an den Produkten vorgenommen, Teile ausgewechselt oder Verbrauchsmaterialien verwendet, die nicht den Originalteilen entsprechen, so entfällt jegliche Gewährleistung oder Haftungsansprüche.

**(CZ) Vážený zákazník,**

jako výrobce nábytku bychom Vás chtěli informovat o tom, že upevnění je jen tak dobré, jak dobré je spojení mezi upevňovacím materiálem (hmoždinkou) a zdívkou. U závěsných prvků zkontrolujte příslušné zdivo a používejte jen vhodné hmoždinky, které nakoupíte v odborných obchodech. Za upevnění ve zdivu je nakonec zodpovědný ten, kdo upevnění montuje.

Montáž a instalaci elektrických částí směřjí provádět jen pověřeni odborní pracovníci. Dodržujte popisy a údaje o hmotnosti uvedené v návodu k montáži.

Dodržujte uvedené údaje o maximální hmotnosti při přetížení, které je způsobeno hrajícími si dětmi, lidmi, materiálem nebo jinými vlivy, nepřebíráme jako výrobce nábytku záruku!

Bezvadná funkce nábytku je zaručena jen při postavení nábytku ve správné svislé a vodorovné poloze. Dvířka jsou předem nastavená, případně je ale nutné je znovu seřadit / nastavit podle místních podmínek!

Všechny elektrické instalace jsou provedeny podle platných norem příp. předpisů VDE (svaz německých elektrotechniků), CE, MM. Intenzita žárovky/zdroje světla, která se má použít, je uvedena na příslušné objímce žárovky/zdroje světla. Při nedodržení maximálního výkonu ve Wattch hrozí nebezpečí vznícení kvůli přehřátí. Zakrytí žárovky/zdroje světla je kvůli nebezpečí požáru zakázáno! Všechny šrouby a nosné spojovací prvky se mají po 5 až 6 týdnech dotáhnout, čímž se zajistí trvalá stabilita!

**Nepoužívejte žádné abrazivní čisticí prostředky!**

Pokud se nedodržují pokyny k provozu, návodu nebo montáži, provádějí se úpravy výrobků, vyměňují se díly za neoriginální nebo se používá spotřební materiál, který neodpovídá originálnímu, zaniká záruka nebo nároky plynoucí z odpovědnosti.

**(SK) Vážený zákazník,**

ako výrobca nábytku by sme Vás chceli informovať o tom, že nové upevnenie je len také dobré, aké dobré je spojenie medzi spojovacím materiálom (hmoždinky) a murivom. Pri visiacich elementoch skontrolujte Vaše murivo a použite na príslušné murivo iba určenú hmoždinku zo stavebnín. V konečnom dôsledku je za upevnenie na murive zodpovedný montér.

Montáž a pokládku elektrických materiálov a spotrebičov smie vykonávať iba autorizovaný odborný personál. Prosíme, dodržte popisy a údaje o hmotnosti v návode na montáž.

Dodržiavajte uvádzané údaje o maximálnej hmotnosti pri preťažení, ktoré môžu spôsobiť hrajuce sa deti, ľudia, materiál, alebo iné vplyvy - my, ako výrobca nábytku nepreberáme žiadne ručenie!

Bezchybná funkcia nábytku je zaručená iba pri kolmoh a vodorovnom postavení. Dvere sú vopred nastavené, v prípade potreby na základe miestnych podmienok je však nutné ich znovu vyvážiť/nastaviť!

Všetky elektrické instalácie sú zhotovené podľa platných noriem, resp. predpisov VDE, CE, MM. Sila osvetľovacích telies, ktoré sa majú použiť, je uvedená na objímkach príslušných žiaroviek.

Pri nedodržaní maximálnych Wattov vzniká na základe prehriatia riziko požiaru. Neprikrývajte osvetľovacie teliesá kvôli riziku požiaru!

Všetky skrutky, ako aj nosné spojovacie diely by sa mali po 5 až 6 týždňoch dotiahnuť, aby bola zaručená trvalá stabilita!

**Nepoužívejte žádné drsné čistiace prostředky!**

Ak nebudú dodržané prevádzkové návody, návody na obsluhu alebo montáž, ak sa budú na produktoch vykonávať zmeny, vymieňať diely alebo ak sa bude používať spotrebný materiál, ktorý nezodpovedá originálnym dielom, odpadá akákoľvek záruka alebo akékoľvek nároky na ručenie.

**(GB) Dear Customer,**

As a furniture manufacturer we would like to point out that an attachment is only as good as the connection between the attachment material (dowel) and masonry. In the case of suspension elements you should check your masonry and only use the appropriate dowels from a specialist store. Ultimately it is the person carrying out the installation who is responsible for attachment to the masonry.

The installation and laying of electrical lines and other items must only be performed by authorised specialists. Please note the descriptions and weight information in the installation instructions.

Please observe the stated maximum weights; in the case of mechanical overloads caused by playing children, other individuals, materials etc. we do not accept any liability as the manufacturer of the furniture!

The furniture is only guaranteed to work perfectly if it is set up to be plumb and horizontal. The doors have been pre-adjusted, but may need to be realigned/readjusted in accordance with local conditions!

All electrical installations have been produced in accordance with the latest norms and regulations, such as those of the VDE (Association of German Electrical Engineers), CE and MM. The power of the bulbs to be used is marked on the respective light fitting.

If the maximum number of watts stated on the fitting is not complied with, there is a danger of fire from overheating. Covering the lamps and bulbs is strictly prohibited due to the danger of fire!

All screws and load-bearing connecting parts should be tightened after 5 to 6 weeks in order to ensure long-term stability!

**Do not use any abrasive cleaning materials!**

If the operating or installation instructions are not complied with, modifications are carried out to the products, parts replaced or consumable materials used which do not correspond to the original parts, all warranty or liability claims shall become null and void.

**(HU) Tisztelt Ügyfelünk!**

Mint bútorgyártó arról szeretnénk tájékoztatni Önt, hogy a rögzített szerkezetek minősége a rögzítő anyag (tipli) és a fal közti összeköttetés minőségétől függ. Falra szerelt egységek esetén ellenőrizze a fal adottságait és csakis szakkereskedelemből származó, a rögzítéshez megfelelő tipliket használjon. Végső soron a bútort felszerelő személy felelős a falra történő rögzítésért.

A villamossági cikkek szerelését és elhelyezését csakis erre jogosult szakember végezheti. Kérjük, vegye figyelembe az összeszerelési útmutatóban szereplő leírásokat és súlyadatokat.

Tartsa be a megadott maximális súlyhatárokat. A bútor játszó gyermekek, személyek, anyagok vagy egyéb behatások okozta túlterhelésért a bútorgyártót nem terheli felelősség.

A bútor kifogástalan működése csakis pontosan függőleges helyzetben garantált. Az ajtók előre be vannak állítva, a helyi adottságok függvényében azonban szükség esetén újra be kell állítani/igazítani őket.

A villamos berendezések a német VDE, CE és MM érvényes szabványainak és előírásainak megfelelően készültek. A világítótestek megfelelő erőssége az adott lámpa foglalattán található meg.

A max. watt-szám be nem tartása esetén túlforrósodás következtében fellépő tűzveszély áll fenn. A világítótesteket tűzveszély miatt nem szabad letakarni!

Minden csavart és tartó összekötő részt 5-6 hét elteltével újra meg kell húzni a bútor álló helyzetben való tartós biztonsága érdekében.

**Nem használjon habzó tisztítószereket!**

Az üzemeltetési, kezelési ill. szerelési útmutató utasításainak be nem tartása, a terméken végzett változtatások, részek kicserélése, vagy az eredeti részeknek meg nem felelő anyagokat felhasználása esetén mindennemű szavatosság és felelősség kizárt.

**(HR) Spo.tovani,**

kot proizvajalec pohi.tva vas .elimo informirati, da je pritrđitev samo tako mo.na, kot je mo.na povezava med pritrđilnim materialom (moznikom) in zidom. Pri elementih, ki so obe.eni, preverite zid in uporabite samo za zidove primerne moznike, ki ste jih nabavili v strokovni trgovini. Nenazadnje odgovarja monter za pritrđitev. Elektri.ne artikle naj vam polo.i in montira strokovnjak. Pri tem upo.tevajte opise ter podatke o te.i v navodilih za monta.o.

Upo.tevajte podano maksimalno te.o - pri previsokih obremenitvah, ki nastanejo zaradi igranja otrok, bremen ljudi ali drugega materiala ali zaradi drugih obremenitev . kot proizvajalec pohi.tva ne prevzemamo nikakr.ne odgovornosti!

Pravilno delovanje funkcij pohi.tva je zagotovljeno samo pri pravilni vodoravni in pravokotni postavitvi. Vrata so predhodno justirana, vendar jih je treba zaradi lokalnih pogojev na novo nastaviti!

Vse elektri.ne instalacije so izdelane v skladu z veljavnimi standardi oz. predpisi VDE, CE in MM. Jakost uporabljenih .arnic je vedno navedena na vsakem posameznem okviru za svetilo.

Pri neupo.tevanju maks. .tevila vatov obstaja zaradi pregretja nevarnost po.ara. Svetil zaradi nevarnosti po.ara ni dopustno prekrivati!

Vse vijake in nosilne povezovalne dele po 5 do 6 tednih naknadno privijajte, da boste zagotovili stalno trdnost povezav!

Ne uporabljajte .istil za drgnjenje!

V primeru neupo.tevanja navodil za delovanje, uporabo in monta.o, in v primeru izvajanja sprememb na produktih ter menjave delov ali porabnega materiala, ki ne ustrezajo originalnim delom, izgubi kupec vse pravice do uveljavljanja garancije.

**(I) Gentile cliente,**

in qualità di produttori di mobili desideriamo informarla del fatto che un fissaggio può essere solo veramente buono se anche il collegamento tra il materiale di fissaggio (bullone) e le mura è altrettanto buono. Nel caso degli elementi che pendono controllate le vostre mura ed utilizzate solamente bulloni previsti a tale scopo che troverete in un mercato specializzato. Infine è il montatore ad essere responsabile per il fissaggio sulla parete.

Il montaggio e la messa in funzione degli apparecchi elettronici devono essere effettuati esclusivamente da parte di personale specializzato. Si prega di rispettare le descrizioni e le indicazioni relative al peso presenti nelle istruzioni per il montaggio.

Si prega di rispettare le indicazioni relative al peso massimo - nel caso di un sovraccarico che può essere causato da bambini che giocano, da persone, da materiale oppure da altri infussi si declina qualsiasi responsabilità!

Il funzionamento corretto del mobile è garantito solamente in caso di un montaggio corretto in posizione orizzontale e come riportato sull'imballaggio. Le porte sono già state anticipate pre-impostate, essere dovranno però, qualora necessario, essere adattate / regolate conformemente alle nuove condizioni ambientali!

Tutte le installazioni elettriche sono preparate secondo le norme e le regole vigenti VDE, CE, MM. La potenza dei mezzi d'illuminazione da utilizzarsi è riportata sul rispettivo zoccolo della lampada.

In caso di mancato rispetto del numero massimo di Watt può verificarsi un surriscaldamento con il pericolo d'incendio. È vietato coprire i mezzi d'illuminazione perché sussiste pericolo d'incendio!

Tutte le viti e gli elementi portanti di collegamento dovrebbero essere ri-aggiustati dopo 5 o 6 settimane al fine di garantire un funzionamento sicuro continuativo!

**Non utilizzare mezzi di pulizia che creino polvere di pulizia!**

In caso di mancato rispetto delle indicazioni per l'esercizio, il comando o il montaggio, nel caso in cui venissero effettuate delle modifiche ai prodotti, in cui venissero sostituiti degli elementi oppure in cui venissero utilizzati dei materiali ausiliari che non corrispondono ai pezzi originali, allora non sarà più esigibile nessuna garanzia o nessuna richiesta di garanzia.

**(NL) Geachte klant,**

Als meubelproducent willen wij u erover informeren dat een bevestiging slechts zo goed is als de verbinding tussen het bevestigingsmateriaal (plug) en de muur. Controleer daarom bij aan de muur hangende elementen uw muurconstructie en gebruik alleen hiervoor geschikte pluggen uit een speciaalzaak. Tenslotte is de monteur verantwoordelijk voor de bevestiging aan de muur.

De montage en het leggen van kabels van elektrische artikelen mag uitsluitend door hiervoor bevoegd vakpersoneel worden uitgevoerd. Houd ook rekening met de beschrijvingen en de vermelde gewichten in de montagehandleiding.

Neem de aangegeven maximumgewichten in acht. Bij overbelasting die door spelende kinderen, personen, materiaal of overige invloeden ontstaat, zijn wij als meubelproducent niet aansprakelijk!

Het onberispelijk functioneren van het meubel is alleen gegarandeerd, wanneer dit horizontaal en verticaal waterpas wordt opgesteld. De deuren zijn vooraf ingesteld, moeten echter eventueel door de omstandigheden ter plaatse opnieuw worden afgesteld / ingesteld!

Alle elektrische aansluitingen voldoen aan de geldende normen resp. voorschriften van VDE, CE, MM. Het te gebruiken lampwattage is aangegeven op de betreffende lampfitting.

Wanneer het maximaal geoorloofde wattage niet wordt aangehouden, bestaat brandgevaar door oververhitting. Het afdekken van de lamp is in verband met brandgevaar verboden!

Alle schroeven en dragende verbindingselementen moeten na 5 à 6 weken worden aangedraaid om een duurzame stabiliteit te waarborgen!

**Gebruik geen schurende schoonmaakmiddelen!**

Wanneer gebruiksvorschriften, bedienings- of montage-instructies niet worden opgevolgd veranderingen aan de producten worden uitgevoerd, onderdelen worden vervangen of verbruiksmaterialen gebruikt, die niet overeenkomen met de originele onderdelen, vervalt iedere garantie of aansprakelijkheid.

**(BG) Многоуважаеми клиенти,**

като производител на мебели, ние желаем да Ви информираме, че дадено закрепване е само толкова добро, колкото връзката между закрепващото средство (дюбел) и зидарията. При висящи (окачени) елементи проверявайте Вашата зидария и използвайте само предвидени за целта дюбели от специализирани магазини. В края на краищата, монтьорът е отговорен за закрепването на зидарията. Монтажът и полагането на електрически части трябва да се извършва само от оторизирани специалисти. Съблюдавайте описанията и данните за теглото в инструкцията за монтаж. Спазвайте указаните макс. данни за тегло – като производител на мебели, ние не поемаме отговорност при претоварване, причинено чрез играещи деца, хора, материали или други влияния!

Безупречното действие на мебелите се гарантира само при вертикален и хоризонтален монтаж. Вратите са предварително юстирани, но при необходимост поради локалните условия трябва да се изравняват / регулират!

Всички електрически инсталации са произведени съгласно валидните норми, съотв. разпоредби на VDE, CE, MM. Силата на осветителните тела, която трябва да се използва е указана на съответната фасунга на лампата.

При непродържане към макс. мощност съществува опасност от пожар чрез прегряване. Поради опасност от пожар не трябва да се извършва покриване на осветителното тяло!

За гарантиране на продължителна стабилност, всички болтове, както и носещи свързващи части трябва да се затегнат допълнително след 5 до 6 седмици!

**Не използвайте триещи почистващи средства!**

Ако инструкциите за експлоатация, обслужване или монтаж не се съблюдават, ако се извършат промени на продуктите, ако се подменят части или се използват консумативи, които не отговарят на оригиналните части, в този случай отпада всякаква отговорност или гаранционни права.

**(F) Cher client,**

En tant que fabricant de meubles, nous souhaitons attirer votre attention sur le fait que la meilleure des fixations n'est rien sans la qualité du raccord entre le matériel de fixation (cheville) et la maçonnerie. Par conséquent, pensez à vérifier la maçonnerie avant d'accrocher les éléments hauts et utilisez uniquement les chevilles prévues à cette fin, achetées dans une grande surface spécialisée. En fin de compte, c'est l'installateur qui sera responsable de la fixation à la maçonnerie.

Le montage et la pose des articles d'électroménager sont strictement l'affaire d'un personnel qualifié, dûment habilité. Veuillez observer les descriptions et les poids indiqués dans la notice de montage.

Veillez respecter les poids maxi spécifiés ; en tant que fabricant de meubles, nous déclinons toute responsabilité en cas de surcharges causées par des enfants qui jouent, d'autres personnes, du matériel divers ou provoquées par d'autres influences !

Pour assurer le fonctionnement irréprochable du meuble, il faut veiller à l'installer parfaitement d'aplomb et à l'horizontale. Les portes sont préajustées, mais il sera peut-être nécessaire de les réaligner/régler à nouveau sur place !

Toutes les installations électriques sont fabriquées selon les normes et prescriptions VDE, CE, MM en vigueur. La puissance à utiliser est précisée sur la douille de chaque lampe.

Si le wattage max. n'est pas respecté, il existe un risque d'incendie dû à la surchauffe. Il est interdit de recouvrir la lampe, en raison du risque d'incendie !

Il faut resserrer toutes les vis et les éléments de raccord porteurs après 5 à 6 semaines, pour assurer une stabilité durable !

**N'employez en aucun cas des nettoyeurs abrasifs !**

Si les instructions de service, de commande ou de montage ne sont pas respectées, si des modifications sont apportées aux produits ou bien encore si des pièces sont remplacées ou si des consommables qui ne correspondent pas aux pièces d'origine sont utilisés, nous n'assurons alors aucune garantie et nous déclinons toute responsabilité dans ces cas.

**(PL) Szanowni Klienci!**

Jako producent mebli pragniemy Państwu przypomnieć, że umocowanie mebli jest tak dobre, jak dobre jest połączenie pomiędzy materiałem mocującym (kołkiem rozporowym) a ścianą. Proszę zatem w przypadku elementów wiszących sprawdzić wytrzymałość muru i użyć do ich zamocowania wyłącznie przeznaczonych do tego kołków ze sklepu specjalistycznego. Ostateczną odpowiedzialność za przymocowanie do ściany ponosi monter mebli.

Montaż artykułów elektrycznych i ich ułożenie należy powierzyć wyłącznie autoryzowanemu personelowi. Proszę zastosować się do opisów oraz ciężarów podanych w instrukcji montażu.

Proszę przestrzegać podanych ciężarów maksymalnych. W przypadku nadmiernego obciążenia, powstałego w wyniku bawiących się dzieci, osób, materiału lub z innych powodów jako producent mebli nie ponosimy odpowiedzialności!

Nienaganne funkcjonowanie mebla jest zagwarantowane wyłącznie w przypadku jego prawidłowego pionowego i poziomego ustawienia. Drzwi zostały odpowiednio ustawione, ale ze względu na warunki lokalne należy je ewentualnie ustawić na nowo/wyregulować!

Wszystkie instalacje elektryczne wykonano zgodnie z obowiązującymi normami lub przepisami VDE, CE, MM. Na każdej oprawce lampowej podana jest moc żarówek, których należy używać.

W przypadku nieprzestrzegania maksymalnej ilości watów istnieje niebezpieczeństwo pożaru w wyniku przegrzania. Żarówek nie wolno przykrywać ze względu na niebezpieczeństwo pożaru!

Dla zapewnienia trwałej stateczności po 5-6 tygodniach należy dokręcić wszystkie śruby i nośne elementy łączące!

**Nie używać żadnych środków czyszczących wymagających szorowania!**

W przypadku nieprzestrzegania instrukcji użytkowania, obsługi i montażu, dokonywania zmian w produktach, wymiany części lub używania materiałów zużywających się, które nie odpowiadają częściom oryginalnym, wyklucza się jakąkolwiek gwarancję lub roszczenia z tytułu odpowiedzialności cywilnej.

**(SLO) Cijenjeni kupče,**

kao proizvođač namještaja želimo Vas informirati o tome da učvršćenje drži ukoliko je dobar spoj između materijala za pričvršćenje (moždanik) i zida. Kod viših elemenata ispitajte zide i koristite samo moždanike predviđene za to iz specializirane stručne trgovine. Najzad, monter je odgovoran za učvršćenje na zidu.

Montažu i položanje elektro-artikala može izvršavati samo autorizirano stručno osoblje. Pazite na opise i podatke o težini u uputstvu za montažu.

Pridržavajte se navedenih podataka o maksimalnoj težini u slučaju preopterećenja izazvanih zbog djece koja se igraju, ljudi, materijala ili drugih utjecaja kao proizvođač namještaja ne preuzimamo garanciju!

Besprijeckorna funkcija namještaja je zajamčena samo kod vertikalne i vodoravne montaže. Vrata su prednamještena, ali u danom slučaju se moraju nanovo centrirati / podesiti, na osnovi lokalnih uvjeta!

Sve električne instalacije su izvedene prema vrjedječim VDE-, CE-, MM-normama odnosno -propisima. Jačina rasvjetnog sredstva koju treba koristiti, navedena je na dotičnom grlu žarulje.

U slučaju nepridržavanja maksimalne vataže, postoji opasnost od požara zbog pregrijavanja. Ne smije se pokriti rasvjetno sredstvo zbog opasnosti od požara!

Sve vijke kao i noseće spojne dijelove treba naknadno pritegnuti poslije 5 do 6 tjedana da bi tako bila zajamčena trajna stabilnost!

**Nemojte koristiti ribajuća sredstva za čišćenje!**

Ukoliko se na pridržavate pogonskoj uputi, uputi za rad ili za montažu, ako vršite promjene na proizvodima, izmijenite dijelove ili koristite potrošne materijale koji ne odgovaraju originalnim dijelovima, otpada svaka garancija i svaki zahtjev za jamčenjem.

## (RO) Stimate client!

În calitate de producător de mobilă am dori să vă informăm că o fixare poate fi bună doar dacă legătura dintre materialul de fixare (dibluri) și zid este bună. În cazul elementelor suspendate verificați zidul și folosiți doar diblurile prevăzute și achiziționate dintr-un magazin de specialitate. În definitiv montatorul este răspunzător de fixarea pe zid.

Montarea și pozarea articolelor electrice se va efectua doar de către personal calificat și autorizat. Respectați descrierea și specificațiile de greutate din instrucțiunile de montaj.

Vă rugăm să respectați specificațiile date privind greutatea max. - în caz de supraîncărcare ce poate să apară datorită copiilor care se joacă, datorită persoanelor, materialului sau prin alți factori - nu preluăm niciun fel de răspundere ca producător de mobilă!

O funcționalitate perfectă a mobilei este asigurată doar în cazul în care la așezare aceasta se reglează pe orizontală și pe verticală. Ușile sunt deja reglate în prealabil, dar dacă va fi cazul, din motive existente la fața locului, acestea trebuie din nou ajustate / reglate!

Toate instalațiile electrice sunt fabricate conform normelor în vigoare respectiv prevederilor VDE, CE, MM. Puterea necesară a becului este trecută pe dulia respectivă a lămpii.

Dacă nu se respectă puterea max. în Watt există pericol de incendiu datorită supraîncălzirii. Datorită pericolului de incendiu este interzisă acoperirea becurilor! Toate șuruburile și piesele portante de îmbinare trebuie strânse ulterior după 5 până la 6 săptămâni pentru a se asigura o siguranță definitivă a fixării!

## Nu folosiți agenți de curățire abrazivi!

În cazul în care nu se respectă instrucțiunile de utilizare, de deservire sau de montaj, dacă se efectuează modificări ale produselor, dacă se schimbă piese sau se folosesc materiale consumabile care nu corespund pieselor originale, atunci se pierde orice garanție sau pretenție de responsabilitate.

## Estimado cliente:

Como fabricantes de muebles, nos gustaría informarles de que la calidad de una fijación reside en la unión entre el material de fijación (clavija) y la mampostería. Compruebe su mampostería en caso de tratarse de elementos de suspensión y use solo las clavijas previstas para ello adquiridas en un almacén. En último término, el montador es responsable por la fijación en la mampostería.

El montaje y la colocación de componentes eléctricos solo se pueden llevar a cabo por parte de personal especializado autorizado. Observe las descripciones y las indicaciones de peso de las instrucciones de montaje. Respete los datos de peso máximo indicados. En caso de sobrecarga que pueda surgir por juegos de niños, por personas, por material o por otra causa, no asumiremos, como fabricantes, ninguna responsabilidad.

Solo se garantiza una buena función del mueble si está colocado de forma horizontal y perpendicular. Las puertas han sido preajustadas, pero tienen que colocarse/ instalarse de nuevo a causa de las condiciones del lugar de instalación. Todas las instalaciones eléctricas se realizan en conformidad con las normas y directrices vigentes de la VDE, la CE y la MM. La potencia de la fuente luminosa que se utilizará se indica en el portalámparas correspondiente.

Si no se observa el vataje máximo, hay riesgo de incendio en caso de sobrecalentamiento.

No se puede cubrir la fuente luminosa por peligro de incendio.

## No usar productos de limpieza cáusticos

Si no se siguen las instrucciones de servicio, uso o montaje, se efectúan modificaciones en los productos, se cambian piezas o se usan consumibles que no coinciden con las piezas originales, la garantía o los derechos de indemnización correspondientes quedarán invalidados.

## (TR) Değerli Müşterimiz,

Mobilya üreticisi olarak, yapacağınız sabitleme işlemi ancak sabitleme malzemesi (dübel) ve duvar arasındaki bağlantı kadar iyi olabilir. Askı elemanları kullanırken duvarınızı kontrol edin ve sadece buna uygun dübeller kullanın. Duvara yapılacak sabitleme işleminden montaj elemanı sorumludur.

Elektrik ekipmanlarının montajı ve bunların döşenmesi yalnızca yetkili teknik personel tarafından uygulanmalıdır. Montaj talimatında bulunan açıklamaları ve ağırlık bilgilerini dikkate alın.

Belirtilen maks. ağırlık bilgilerine riayet edin. Oyun oynayan çocuklardan, insanlardan, malzemelerden veya başka etkenlerden kaynaklanan aşırı yüklenmelerde mobilya üreticisi olarak sorumluluk kabul etmiyoruz!

Mobilyanın kusursuz halde çalışması dik ve yatay yönde kurulum yapıldığında sağlanır. Kapılar önceden ayarlanmıştır, ancak gerektiğinde yerel koşullardan dolayı yeniden hizalanmalı / ayarlanmalıdır!

Tüm elektrik tesisatları geçerli VDE, CE, MM normlarına veya talimatlarına göre üretilmiştir. Kullanılacak lambanın aydınlatma şiddeti ilgili ampul duyunda belirtilmiştir. Maks. Watt sayısına uyulmadığında aşırı ısınma sonucu yangın riski söz konusudur. Yangın riski nedeniyle lambanın üzerinin örtülmesi yasaktır! Kalıcı bir denge sağlamak için tüm civatalar ve taşıyıcı bağlantı noktaları 5 ila 6 hafta sonra tekrar sıkılmalıdır.

## Aşındırıcı temizlik gereçleri kullanmayın!

Kullanım kılavuzuna veya montaj bakım talimatlarına uyulmazsa, ürünler üzerinde değişiklikler yapılırsa, parçalar değiştirilirse veya orijinal parçalara uygun olmayan sarf malzemeleri kullanılırsa, her tür garanti ve tazminat hakkı geçersiz olur.

## (S) Bästa kund,

I vår egenskap som möbelformerent vill vi informera dig om att en förankring endast är så pass säker som övergången mellan monteringsmaterialet (plugg) och murverket. Innan du monterar vägghängda möbler måste du kontrollera att väggen är lämplig. Använd endast godkända pluggar från en byggmarknad. Tänk på att montören alltid är ansvarig för monteringen på väggen.

Elutrustning får endast monteras och anslutas av behöriga elinstallatörer. Beakta beskrivningarna och viktuppgifterna som anges i monteringsanvisningarna.

Beakta angivna maximala vikter. Vid överbelastningar som kan uppstå t ex av lekande barn, människor, material eller annan påverkan övertar vi inget ansvar som möbelformerent.

Möbeln kan endast öppnas och stängas på avsett vis om den placerats lod- och vågrätt. Luckorna är förjusterade, men måste ev. justeras / ställas in på nytt pga lokala förutsättningar.

Alla elektriska installationer har utförts enligt gällande standarder resp. föreskrifter från VDE, CE och MM. Avsedd styrka för ljuskällorna anges på lampsockeln.

Om det maximala effektvärdet i watt inte beaktas föreligger brandrisk pga överhettning. På grund av brandrisk är det förbjudet att täcka över ljuskällor.

Dra åt samtliga skruvar samt bärande kopplingsdelar på nytt efter fem till sex veckor för att garantera tillräcklig stabilitet.

## Använd inga skurande rengöringsmedel!

Om bruks-, användnings- eller monteringsanvisningarna inte beaktas, om ändringar utförs på produkterna, om delar byts ut eller om förbrukningsmaterial används som inte motsvarar originaldelarna, upphör garantin att gälla, samtidigt som ansvarsanspråk inte längre kan ställas.

## (RUS) Уважаемый клиент!

Являясь производителем мебели, мы хотели бы проинформировать Вас о том, что любой крепеж надежен настолько же, насколько надежно соединение между крепежным материалом (дюбелем) и стеной. Поэтому в случае с подвесными элементами, пожалуйста, проверьте надежность Вашей стены и используйте только подходящие дюбели, которые предлагаются в специальных строительных магазинах. В конечном итоге ответственность за крепеж несет специалист, осуществляющий монтаж.

Монтаж и установку электрического оборудования следует поручать только авторизованному электрику-специалисту. Следуйте описаниям и соблюдайте данные по весу, приведенные в инструкции по монтажу.

Пожалуйста, придерживайтесь указанных максимальных значений по весу. При перегрузках, причиной возникновения которых являются играющие дети, люди, материалы или иные причины, мы, как производители мебели, ответственности не несем!

Безупречные эксплуатационные характеристики мебели обеспечиваются только в том случае, если мебель правильно ориентирована в горизонтальной и вертикальной плоскости. Двери поставляются отрегулированными, однако и они требуют определенной дополнительной настройки с учетом местных условий! Любые электротехнические работы следует осуществлять в соответствии с местными законодательными нормами и предписаниями. Рекомендуемая яркость осветительных элементов указывается на патроне лампы.

При несоблюдении ограничения по максимальной мощности освещения существует опасность пожара вследствие перегрева. По причине опасности пожара запрещается накрывать осветительные элементы!

Все винтовые крепления, равно как и соединительные элементы следует подтянуть через 5 – 6 недель после завершения монтажа для обеспечения долгосрочной надежной фиксации!

## Не пользуйтесь абразивными чистящими средствами!

При несоблюдении инструкций по эксплуатации, обслуживанию и монтажу, а также при осуществлении изменений изделия, замены деталей или применении иных расходных материалов, не соответствующих оригинальным деталям, гарантия прекращает свое действие, равно как и иные претензии, касающиеся ответственности изготовителя.

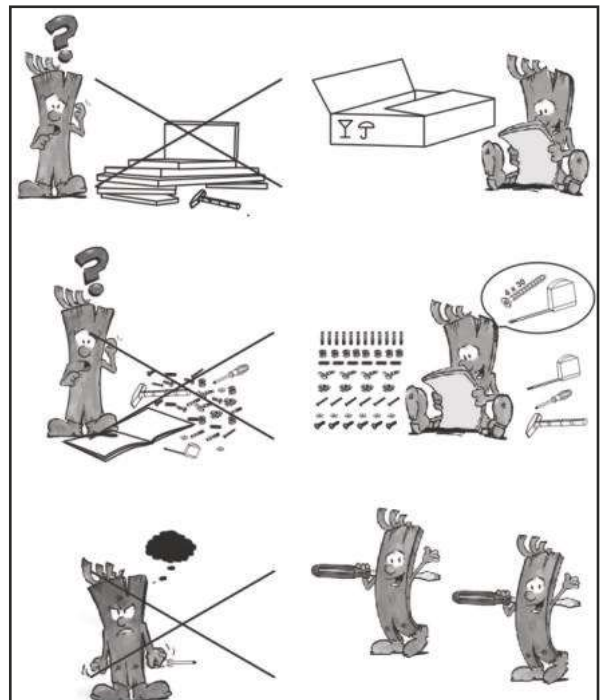



IT

Consigli di manutenzione per facciate lucide di mobili

## Attenzione!

Al momento della consegna, le nostre brillanti superfici sono protette da una pellicola. Lasciarla sul mobile finché non sarà completamente montato e spolverato. Per conservare il pregiato aspetto brillante, osservare i seguenti consigli:

consentire alla pellicola lucida di adattarsi per un'ora al clima dell'ambiente dopo aver tolto la pellicola protettiva, pulire le superfici usando solo un panno di cotone umido e un po' di detergente per vetri. Non utilizzare detergenti aggressivi con additivi. Pulire le superfici passando uno strofinaccio bagnato con una leggera frizione. Non utilizzare pulitori a vapore. Non danneggiare la superficie con oggetti taglienti. Non esporre in nessun caso le superfici a forti radiazioni solari

Con l'augurio che i vostri nuovi mobili possano darvi tante soddisfazioni!

## Area Sviluppato prodotti

Instrucțiuni de întreținere pentru fețe lucioase de mo- bilie

RO

IT

## Attention Remarque !

Nos surfaces haute brillance sont protégées à la livraison par un film protecteur. Veuillez le laisser sur le meuble jusqu'à ce qu'il soit entièrement installé et que la poussière soit supprimée.

Pour obtenir un aspect de qualité et de haute brillance, vous devez

laisser durcir pendant une heure à l'air ambiant le film haute brillance après avoir enlevé le film protecteur pour le nettoyage des surfaces, utiliser uniquement un chiffon de coton humide et un peu de lave-vitre.

Ne pas utiliser de détergent agressif comportant des addi- tifs.

Frictionner les surfaces avec un chiffon humide.

Ne pas utiliser de nettoyeur à vapeur.

ne pas endommager la surface avec des objets coupants ne pas soumettre les surfaces à un fort rayonnement solaire

Nous souhaitons que votre nouveau meuble vous donne entière satisfaction.

## Voire service de développement de produits

FR

RO

## Atenție indicație!

Suprafețele noastre lucioase sunt protejate la livrare cu o folie de protecție. Păstrați-o pe mobilier până la realizarea completă a montajului, respectiv până când nu se mai degajă praf.

Pentru a menține aspectul unic de luciu intens, trebuie s

după îndepărtarea foliei de protecție, asigurați aerisirea foliei lucioase pentru către timp de o oră,

utilizați pentru curățarea suprafețelor exclusiv o cârpă din bambac umezită și puțină soluție de curățat sicla.

nu utilizați detergenți corosivi cu aditivi,

ștergeți suprafețele cu o cârpă umedă,

nu utilizați dispozitive de curățat cu abur.

Nu deteriorați suprafețele cu obiecte ascuțite

Nu expuneți în niciun caz suprafețele la radiații solare intense

Vă dorim multe satisfacții la utilizarea noului dvs. mobilier.

## Departamentul dvs. de creație produse

IT

Consigli di manutenzione per facciate lucide di mobili

FR

Consigne d'entretien pour les faces de meubles de haute brillance

RO

Instrucțiuni de întreținere pentru fețe lucioase de mo- bilie

IT

## Attenzione!

Al momento della consegna, le nostre brillanti superfici sono protette da una pellicola. Lasciarla sul mobile finché non sarà completamente montato e spolverato. Per conservare il pregiato aspetto brillante, osservare i seguenti consigli:

consentire alla pellicola lucida di adattarsi per un'ora al clima dell'ambiente dopo aver tolto la pellicola protettiva, pulire le superfici usando solo un panno di cotone umido e un po' di detergente per vetri. Non utilizzare detergenti aggressivi con additivi. Pulire le superfici passando uno strofinaccio bagnato con una leggera frizione. Non utilizzare pulitori a vapore. Non danneggiare la superficie con oggetti taglienti. Non esporre in nessun caso le superfici a forti radiazioni solari

Con l'augurio che i vostri nuovi mobili possano darvi tante soddisfazioni!

## Area Sviluppato prodotti

Instrucțiuni de întreținere pentru fețe lucioase de mo- bilie

FR

## Attention Remarque !

Nos surfaces haute brillance sont protégées à la livraison par un film protecteur. Veuillez le laisser sur le meuble jusqu'à ce qu'il soit entièrement installé et que la poussière soit supprimée.

Pour obtenir un aspect de qualité et de haute brillance, vous devez

laisser durcir pendant une heure à l'air ambiant le film haute brillance après avoir enlevé le film protecteur pour le nettoyage des surfaces, utiliser uniquement un chiffon de coton humide et un peu de lave-vitre.

Ne pas utiliser de détergent agressif comportant des addi- tifs.

Frictionner les surfaces avec un chiffon humide.

Ne pas utiliser de nettoyeur à vapeur.

ne pas endommager la surface avec des objets coupants ne pas soumettre les surfaces à un fort rayonnement solaire

Nous souhaitons que votre nouveau meuble vous donne entière satisfaction.

## Voire service de développement de produits

RO

## Atenție indicație!

Suprafețele noastre lucioase sunt protejate la livrare cu o folie de protecție. Păstrați-o pe mobilier până la realizarea completă a montajului, respectiv până când nu se mai degajă praf.

Pentru a menține aspectul unic de luciu intens, trebuie s

după îndepărtarea foliei de protecție, asigurați aerisirea foliei lucioase pentru către timp de o oră,

utilizați pentru curățarea suprafețelor exclusiv o cârpă din bambac umezită și puțină soluție de curățat sicla.

nu utilizați detergenți corosivi cu aditivi,

ștergeți suprafețele cu o cârpă umedă,

nu utilizați dispozitive de curățat cu abur.

Nu deteriorați suprafețele cu obiecte ascuțite

Nu expuneți în niciun caz suprafețele la radiații solare intense

Vă dorim multe satisfacții la utilizarea noului dvs. mobilier.

## Departamentul dvs. de creație produse

HU

Pokyn pre ošetrovanie leštených čelých ploch ná- bytku

SK

## Upozornenie!

Leštené plochy sú pri dodaní chránené ochrannou fóliou. Túto fóliu neodstraňujte skôr, ako nábytok zmontujete a zbavíte prachu. Aby ste zachovali vzhľad lešteného povrchu, mali by ste leštenú fóliu po odstránení ochrannej fólie nechať na vzduchu približne jednu hodinu zatvrdnúť.

pre čistenie povrchu používať len vlhkú bavlnenú utierku a malé množstvo umývacieho prostriedku na skla.

Nepoužívajte žiadny ostrý čistiaci prostriedok s prídavnými látkami.

Povrchy vydrhnite mokrú handrou.

Nepoužívajte parný čistíč.

Povrchy nepoškodzujte ostrými predmetmi.

Povrchy v žiadnom prípade nevystavujte silnému slnečnému žiareniu.

Želáme vám veľa radosti s vašim novým nábytkom.

## Váš vývoj výrobku

Ápólsai tanácsok a bútorok fényes homlokzati felületei- hez

HU

CZ

## Pozor upozornění!

Naše povrchy s vysokým leskem jsou při dodání chráněny ochrannou fólií. Ponechte ji na nábytku, dokud nebude kompletně smontovaný a nebude z něho odstraněný prach.

Aby se zachovala cenná optika vysokého lesku, měli byste:

dát vysoce lesklé fólii po odstránění ochranné fólie hodinu čas na vyvržení na pokojovém vzduchu,

pro čištění povrchu používejte pouze vlhký bavlněný hadřík a trochu čistícího prostředku na skla.

nepoužívejte ostrý čistící prostředek s přísadami,

povrchy otřetejte mokrou hadrem,

nepoužívejte parní čistíč.

nepoškodte povrch ostrými předměty

povrchy v žádném případě nevystavujte silnému slunečnímu žárění

Želáme Vám hodně radosti s Vaším novým nábytkem.

Želáme Vám hodně radosti s Vaším novým nábytkem.

## Vaše oddělení vývoje nových výrobků

HU

## Figyelem, olvassa el a tanácsot!

A fényes felületeket a kiszállítás során védőfóliával védjük. Hagyja a fóliát a bútoron addig, amíg azt teljesen össze nem szerelte és nem távolította el róla a por.

Az értékes fényes felület megóvásához tegye a következőket:

Hagyja a fényes fóliát a védőfólia eltávolítása után egy órát keményedni a helyiség levegőjében.

A felületek tisztításához kizárólag nedves pamutkendőt és egy kevés ablaktisztítót használjon.

Ne használjon éles szemmecses tisztítószereket.

A felületet törölje át egy nedves ronggyal.

Ne használjon gőzölős tisztítóeszközt.

A felületet óvja a kemény tárgyakkal való sérüléstől.

A felület mindig óvni kell az erős napsütéstől.

A felület mindig óvni kell az erős napsütéstől.

Reméljük, sok örömet lel az új bútor használatában.

## A termékfejlesztők



HR

Uputa za održavanje  
fronte namještaja visokog  
sijaja

HR

## Pozor uputa!

Naše površine visokog sjaja zaštićene su tijekom isporuke zaštitnom folijom. Ostavite ovu na namještaju, dok nije u cijelosti montiran i oslobođen od prašine.  
Da biste dobili vrijednu optiku visokog sjaja, trebali biste ostaviti foliju visokog sjaja, nakon uklanjanja zaštitne folije, sat vremena na sobnom zraku radi naknadnog otvrdnjavanja; koristiti vlažnu pamučnu krpu i nešto sredstva za čišćenje stakla za čišćenje površina.  
Ne koristiti oštre deterdžente s dodacima, obrisati površine s mokrom krpom, ne koristiti parni čistač, ne oštetiti površinu oštrim predmetima; ne izlagati površine ni pod kojim okolnostima jakom sunčanom ozračavanju.

Želimo Vam puno srećnih trenutaka sa svojim novim amještajem.

## Vaš razvoj proizvoda

Consejo de cuidado para  
muebles con acabado de  
alto brillo

ES

SV

## Observera följande instruktioner!

Vid leveransen är våra höglansytor skyddade med en skyddsfolie. Låt denna vara kvar på möbeln tills den har monterats fullständigt och befriats från damm.  
För att bibehålla det värdefulla höglansutseendet bör du tänka på följande:  
Ge höglansfolien en timmes tid att efterhärdas i rumsluften efter det att skyddsfolien har tagits bort.  
Använd endast en fuktig bomullstrasa med lite glasrengöringsmedel för att rengöra yorna.  
Använd inga skarpa rengöringsmedel med tillsatser.  
Torka av yorna med en fuktig trasa.  
Använd ingen ångrengörare.  
Skada inte ytan med vaassa föremål.  
Utsätt yorna under inga omständigheter för stark solstrålning.

Vi önskar dig mycket glädje med din nya möbel.

## Din produktutveckling

ES

## ¡Atención!

Nuestras superficies con acabados de alto brillo están protegidas por una lámina protectora durante la distribución. Déjala sobre el mueble hasta que haya sido completamente montado y se haya limpiado el polvo.  
Para conservar el aspecto brillante, haga lo siguiente:  
aíree la lámina de alto brillo tras retirar la película protectora durante una hora  
use solo un paño de algodón húmedo y un poco de limpiacris tales para limpiar las superficies  
No use ningún producto de limpieza agresivo con principios activos.

Frote las superficies con un trapo húmedo.

No use vaporera.

No dañe las superficies con objetos cortantes

No exponga las superficies en ningún caso a la luz del sol

Directa

Le deseamos que disfrute de su nuevo mueble.

## El desarrollo de su producto

BG

Указания за поддръжка  
на гланцови  
повърхности на мебели

BG

## Внимание! Указание!

При експедиция нашите гланцови повърхности са покрити със защитно фолио. Оставете го върху мебелите до окончателното им монтиране и почистване от прах.  
За да се запази висококачествения гланц, след отстраняване на защитното фолио оставете гланцовото фолио за един час за допълнително втвърдяване на стайна температура;  
за почистване на повърхностите използвайте само мека памучна кърпа и малко препарат за почистване на стъкла; Не използвайте агресивни почистващи препарати с добавки.

Почиствайте повърхностите с влажна кърпа.  
Не използвайте пароструйка.

Не увреждайте повърхностите с остри предмети.

В никакъв случай не излагайте повърхностите на силно слънчево греене.

Пожелаваме Ви удоволствие с Вашите нови мебели.

## От Отдела за разработване на продукти

SL



## Pozor, napotek!

Naše visokosijajne površine so pri dobavi zaščitene s folijo. Pustite jo na pohištvu, dokler ni v celoti montirano ter ga tako zaščitite pred prahom.  
Da bi ohranili dragocen izgled visokega sijaja, morate visokosijajno folijo po odstranitvi zaščitne folije eno uro dati na sobno temperaturo, da se sirdi  
za čiščenje površin uporabljajte samo vlažno bombažno krpo in malo čistila za steklo  
Ne uporabljajte ostrih čistil z dodatki.  
Površine zrgnite z mokro krpo  
ne uporabljajte parnega čistilnika.  
Ne poškodujte površine z ostrimi predmeti  
V nobenem primeru ne izpostavljajte površin močnim sončnim žarkom

Želimo vam še mnogo veselja z vašim novim pohištvom.

## Vaš razvojni oddelek

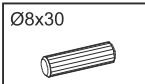
# 1

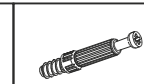
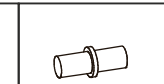
 Ø8x30 A0 x8	 C1 x12	 C2 x8	 H0 x8
---	---	--	--

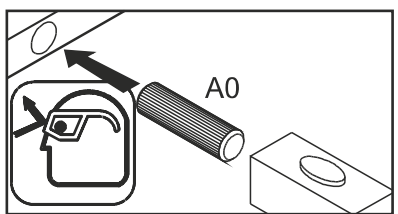
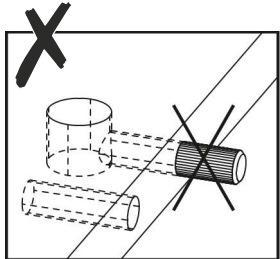
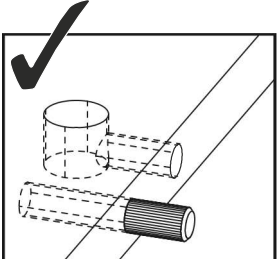
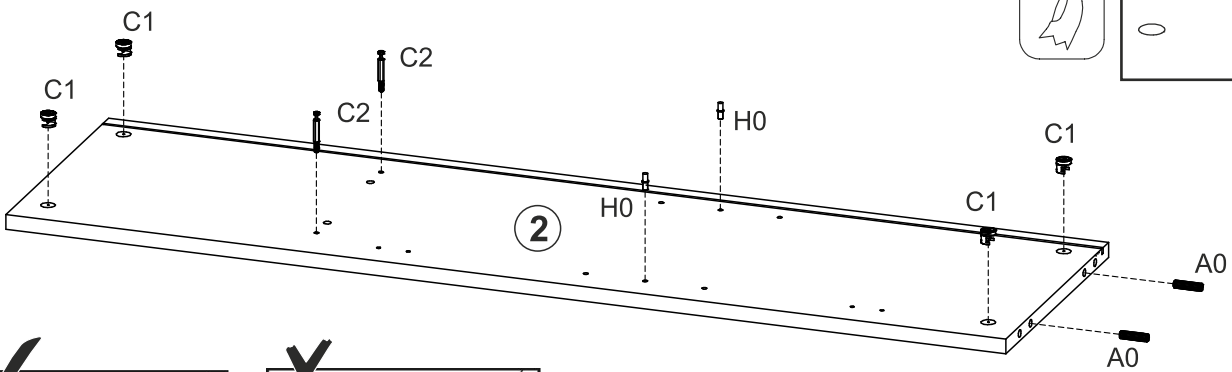
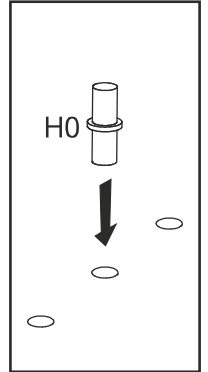
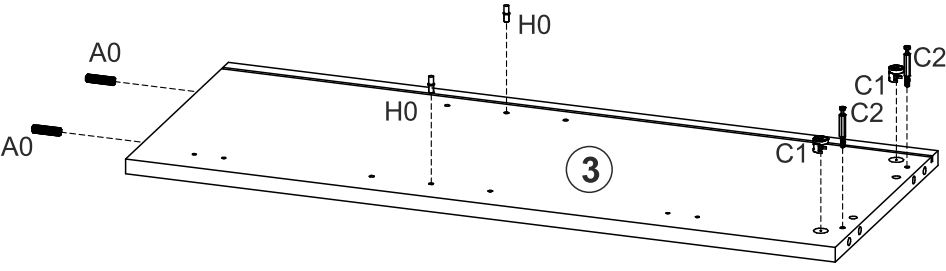
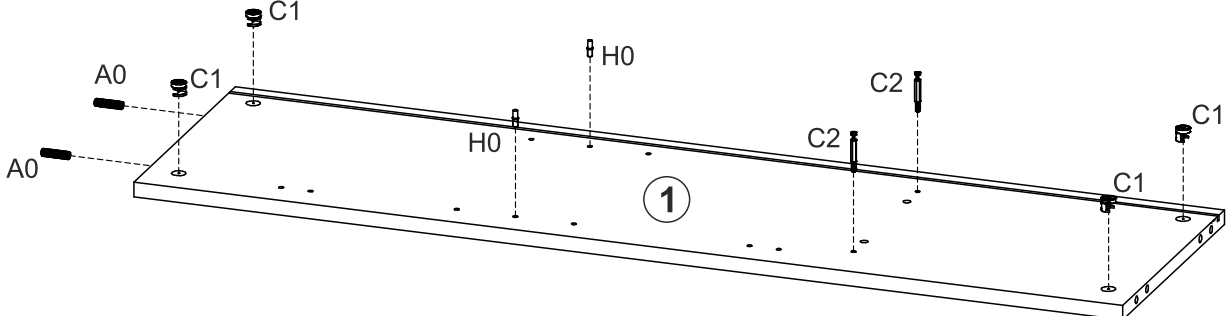
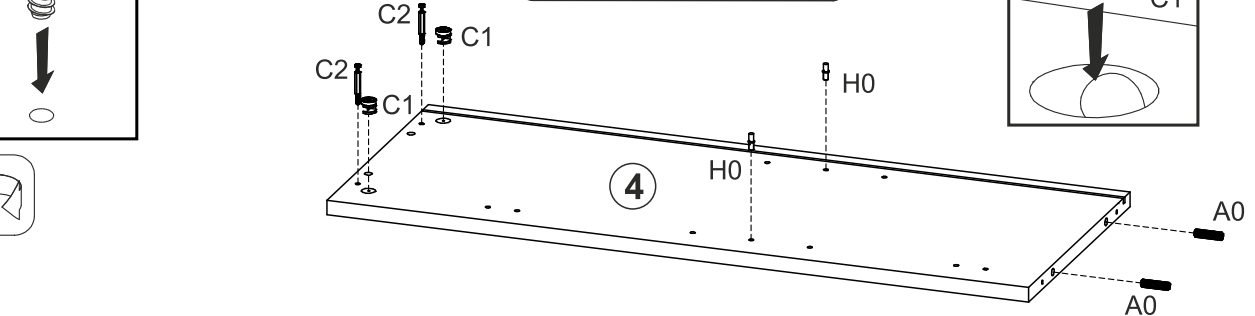
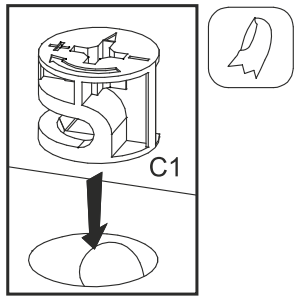
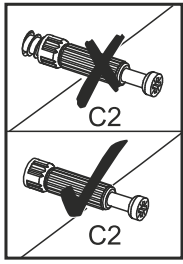
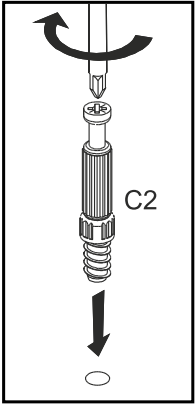
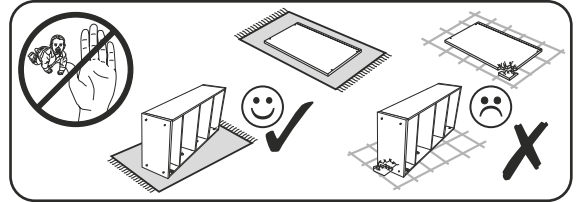

# 2

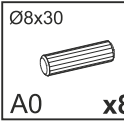
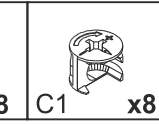
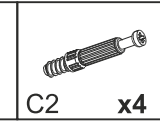
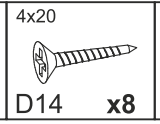
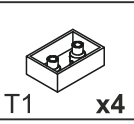
 A0 x8	 C1 x8	 C2 x4	 D14 x8	 T1 x4
---	---	---	--	---

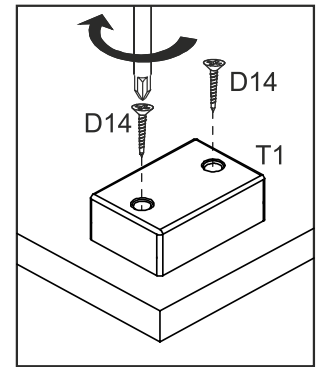
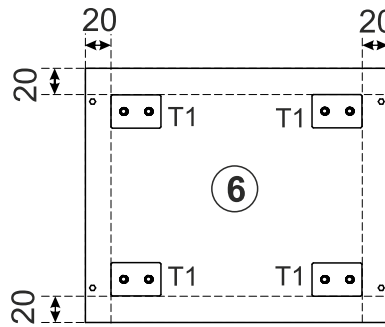
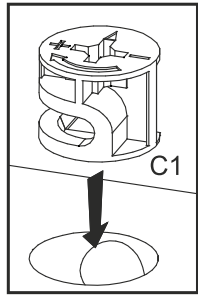
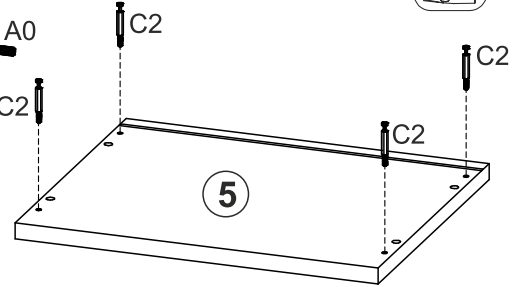
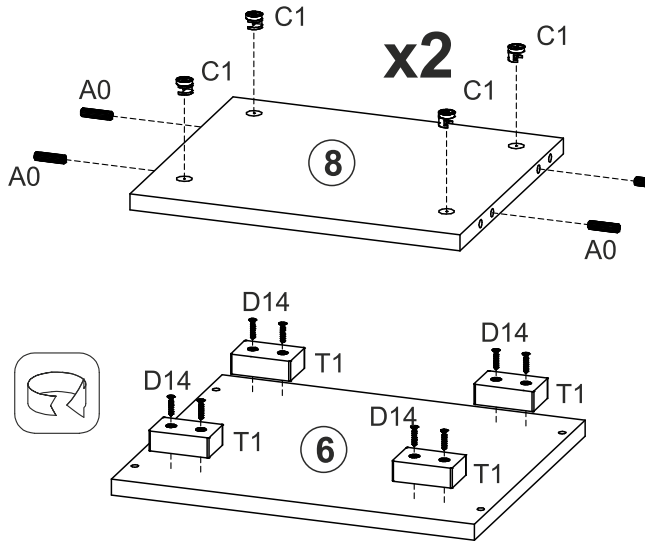
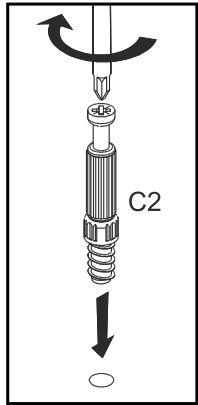
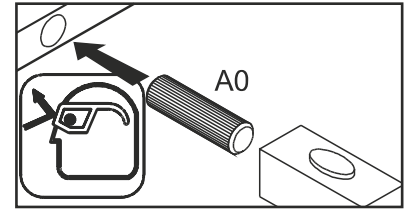

# 3

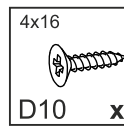
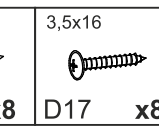
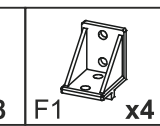
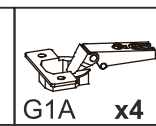
 D10 x8	 D17 x8	 F1 x4	 G1A x4
---	---	--	---

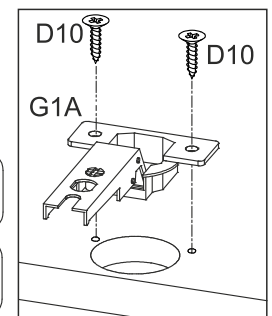
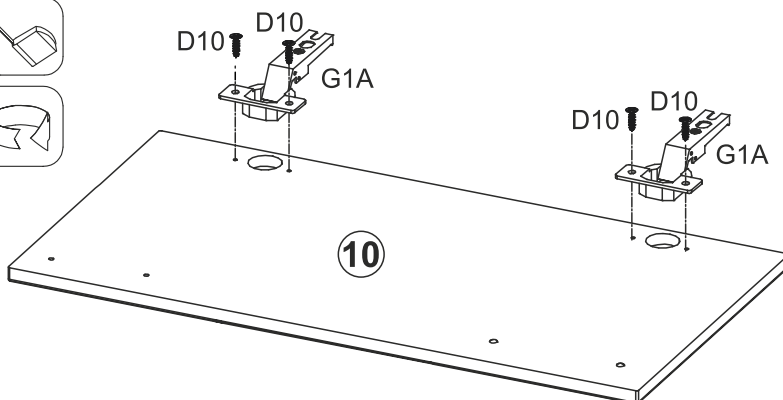
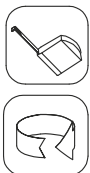
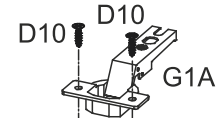
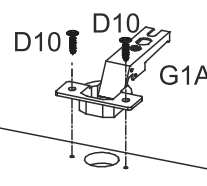
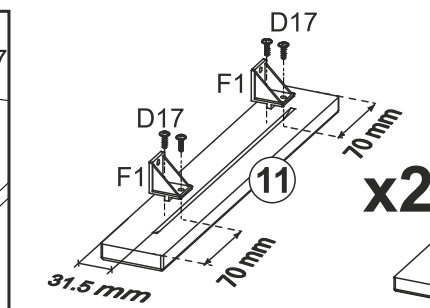
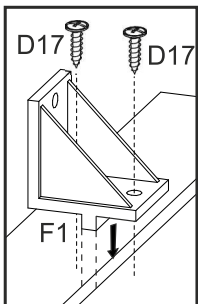
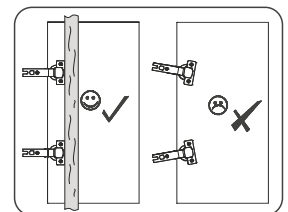

4

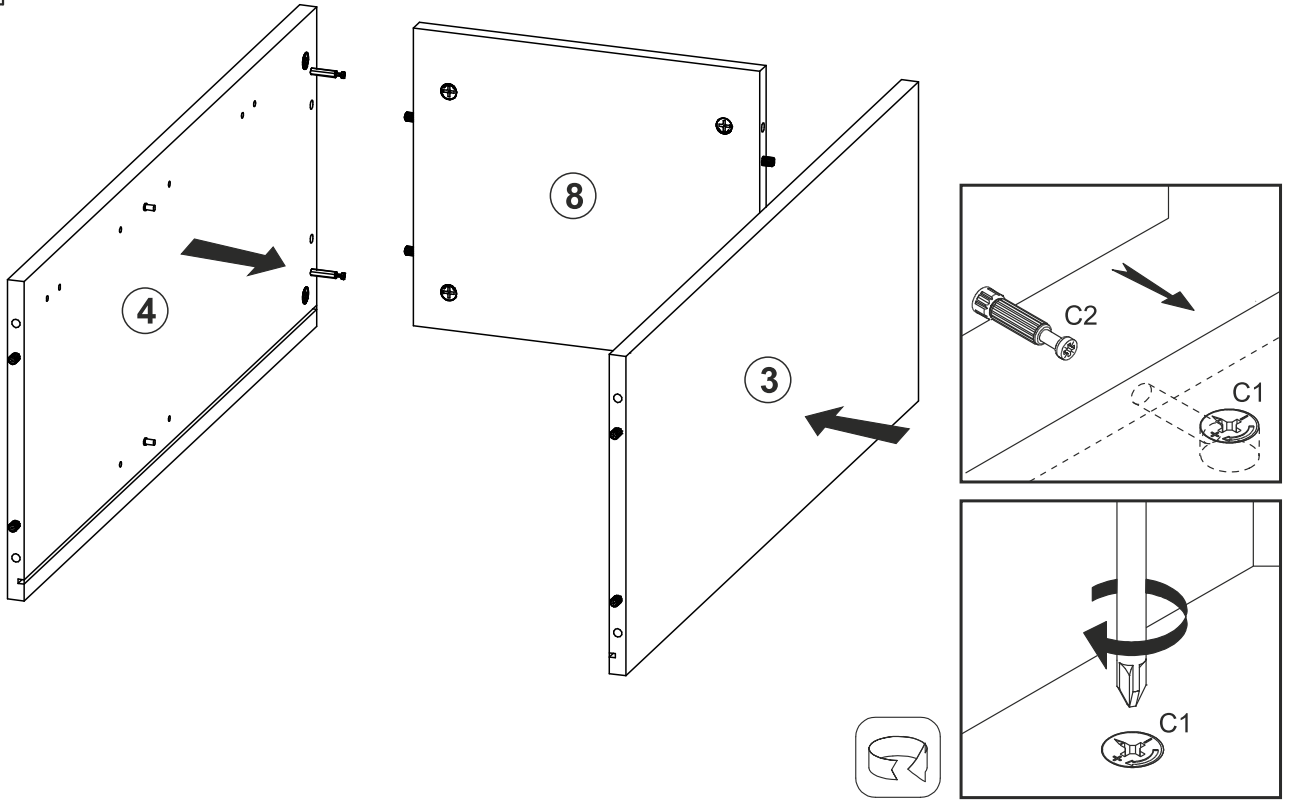

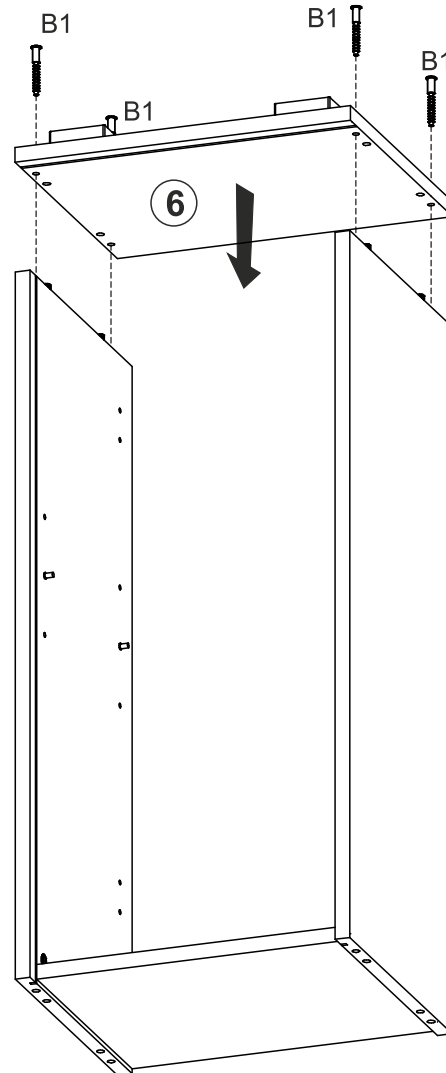
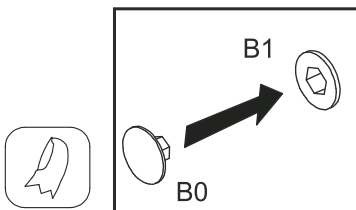
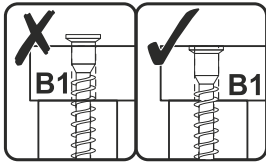
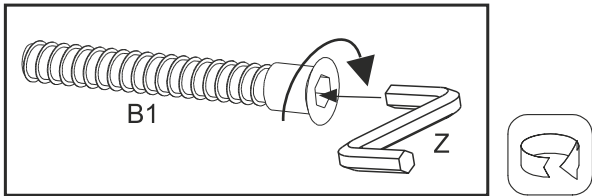
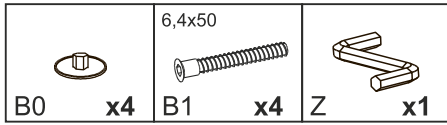

5

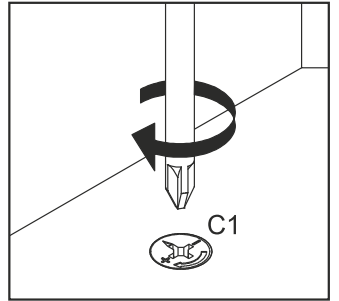
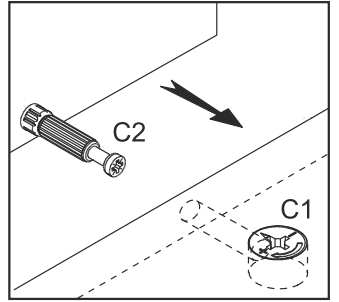
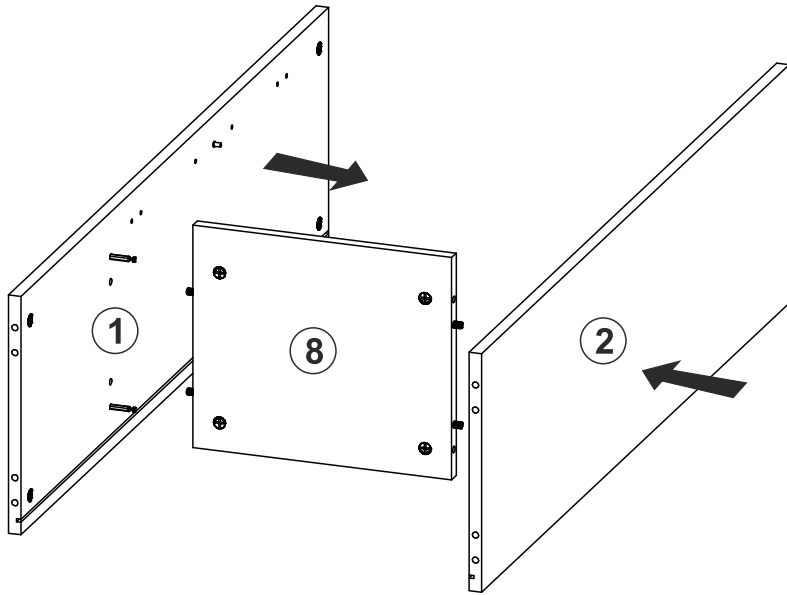

6



7

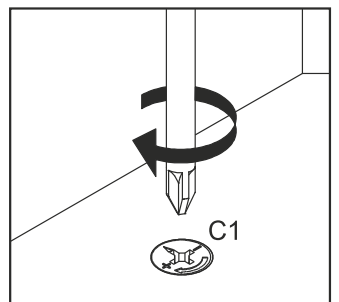
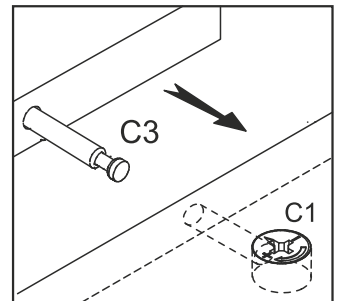
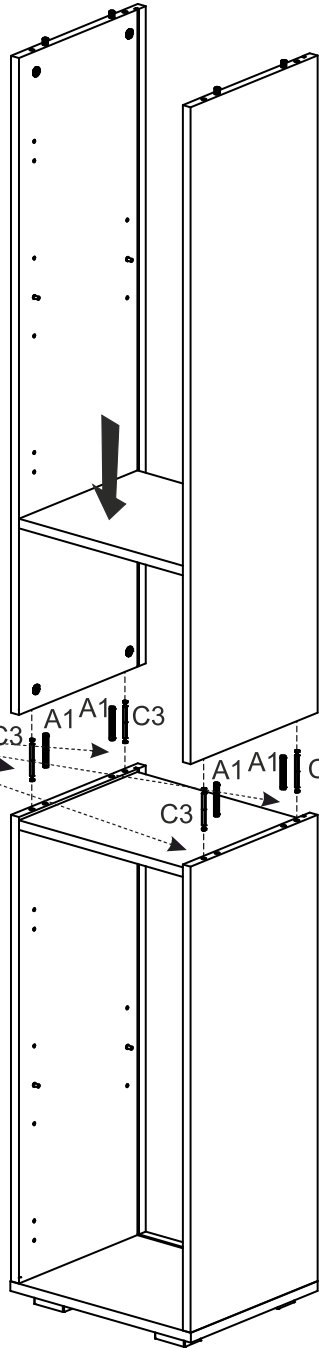
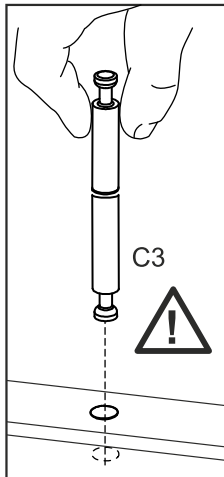

Ø8x50	L-68
	
A1 x4	C3 x4

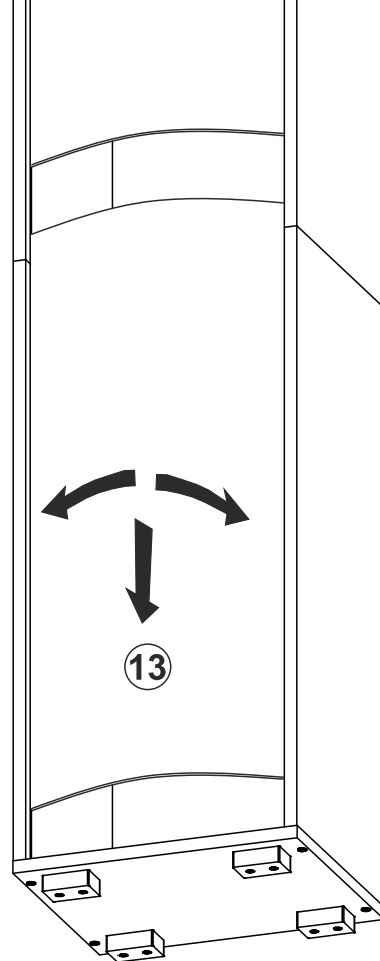
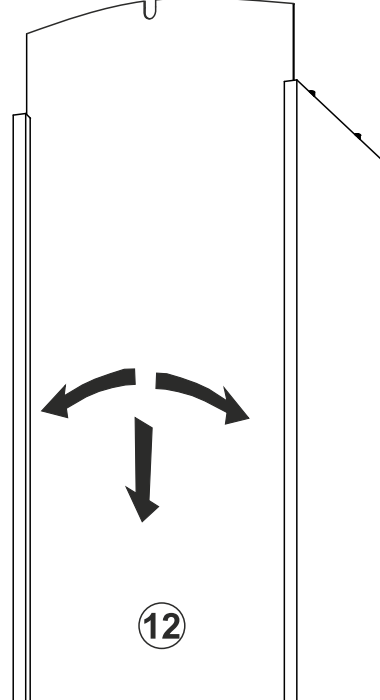
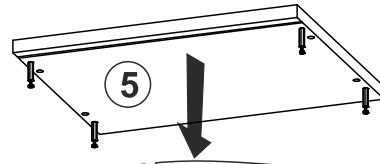
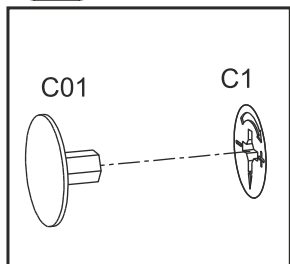
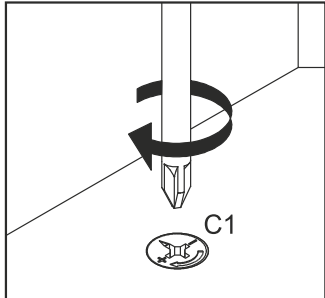
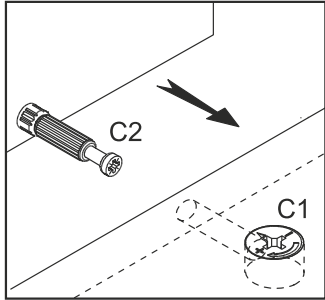
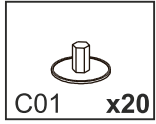

8



9

3x15 	3,5x16 	
D0 x16	D17 x2	F0 x16

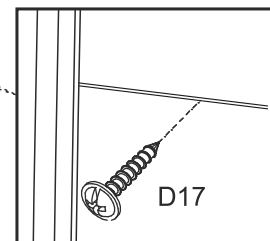
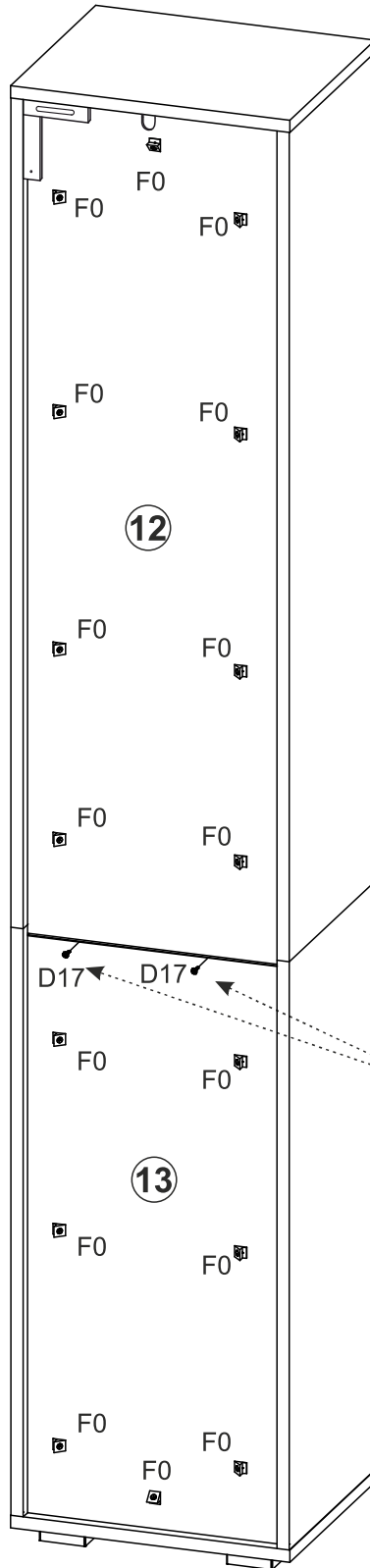
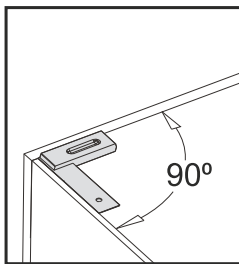
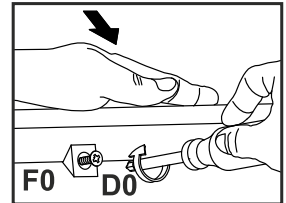
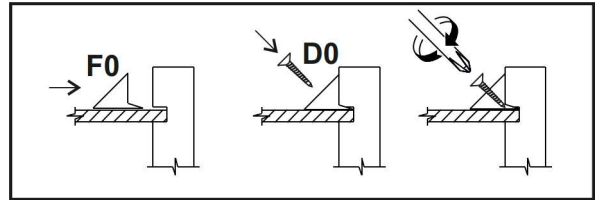

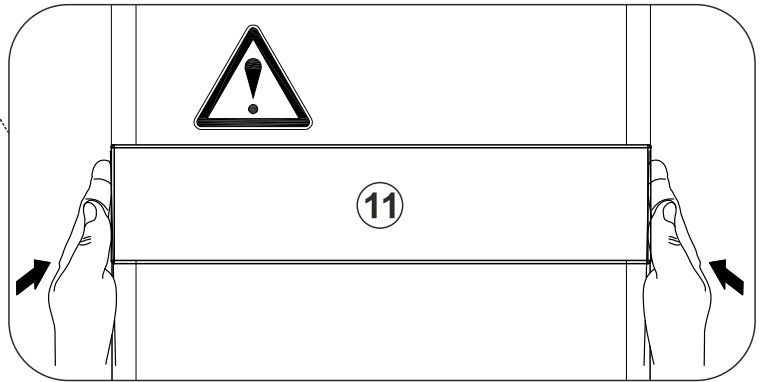
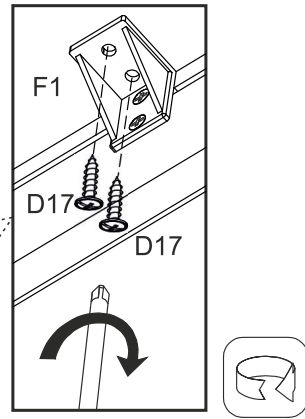
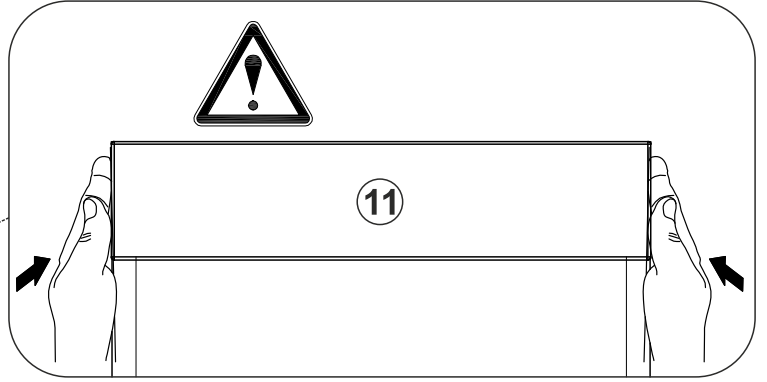
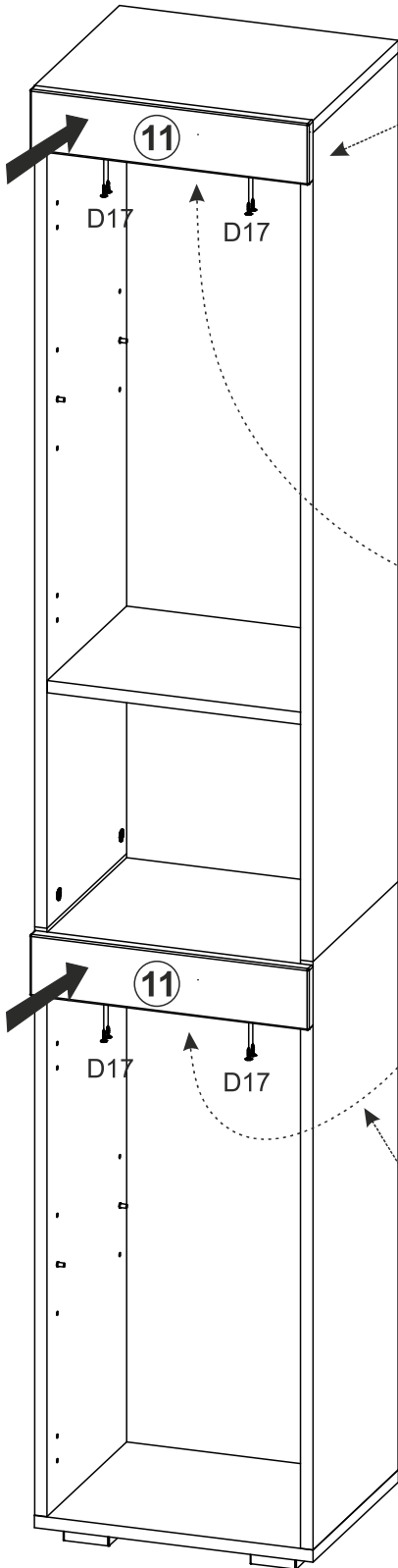
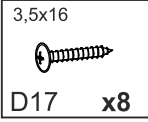

# 10



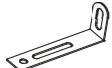

# 11

3,5x16 	5x70mm 8x50mm 	
D17 x2	E2 x1	I1 x1

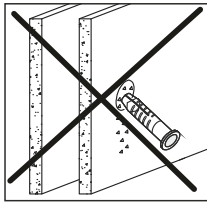
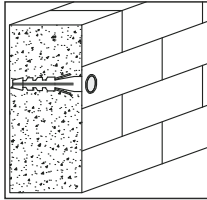

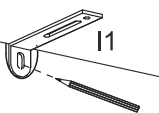
**A**  I1

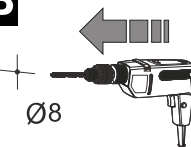
**B**  Ø8

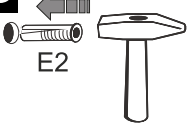
**C**  E2

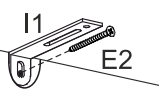
**D**  I1 E2

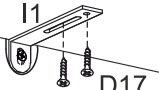
**E**  I1 D17 D17

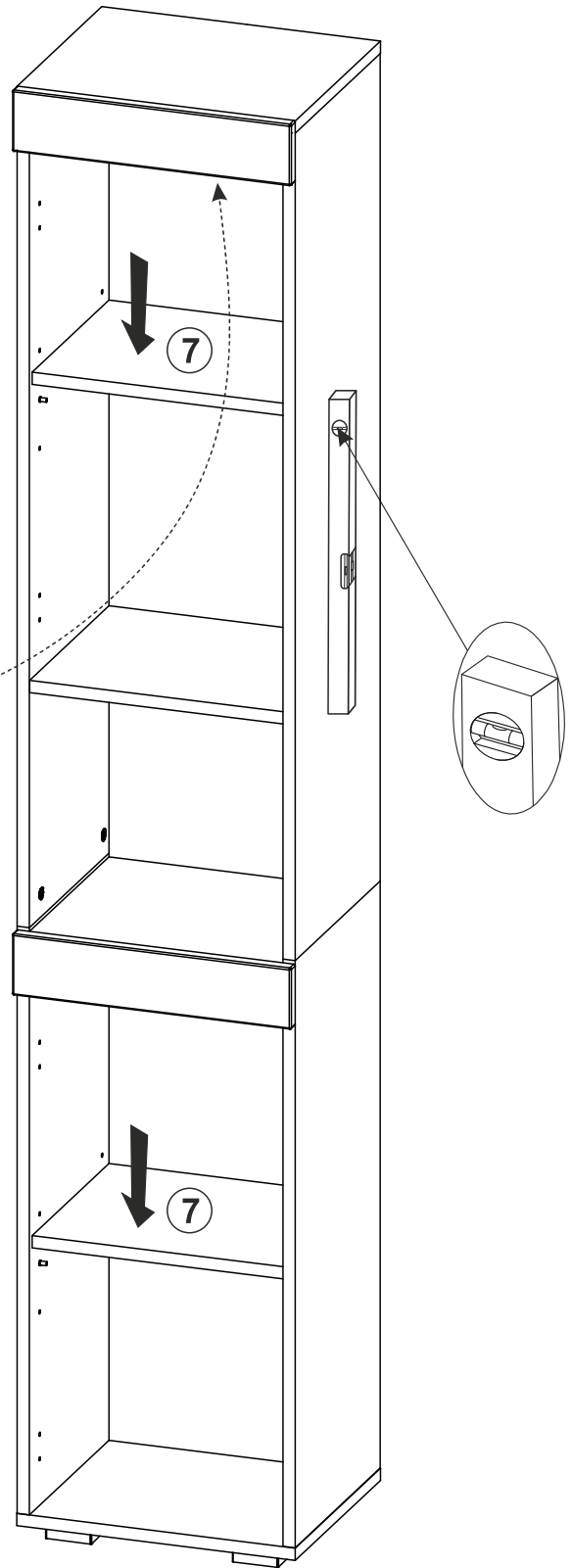
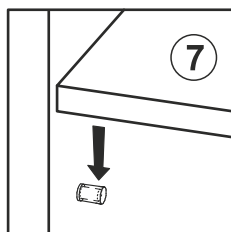

12

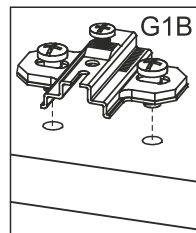
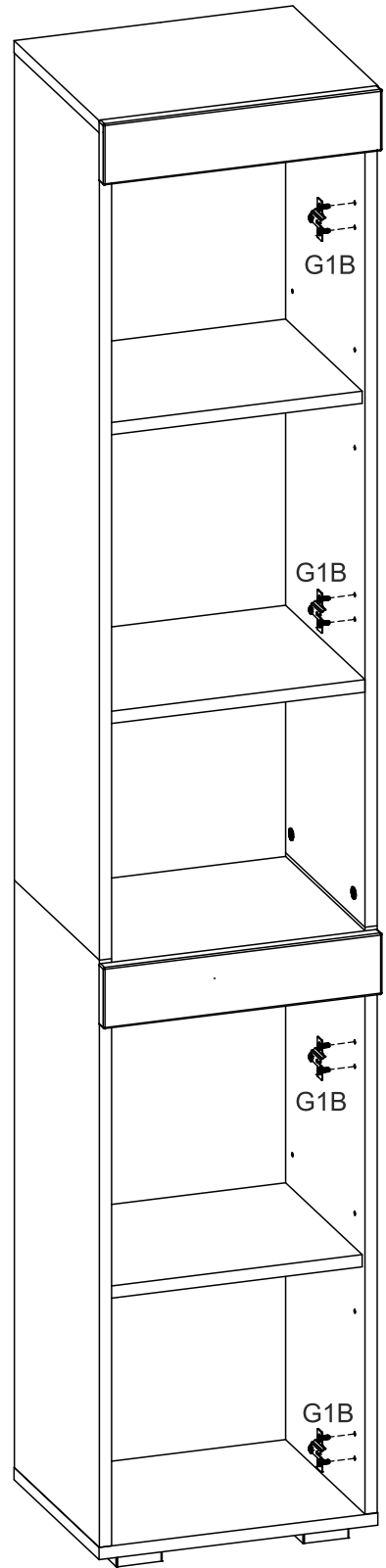
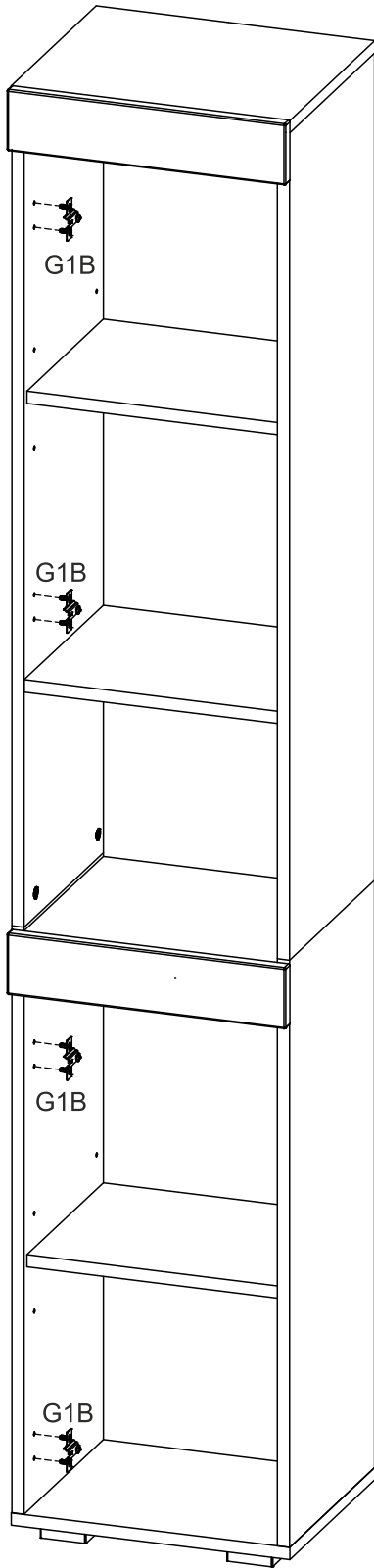
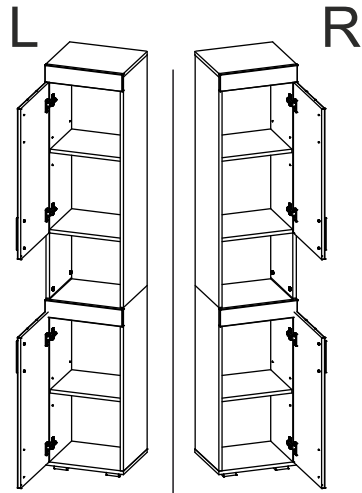
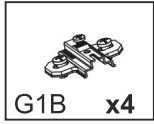

# 13

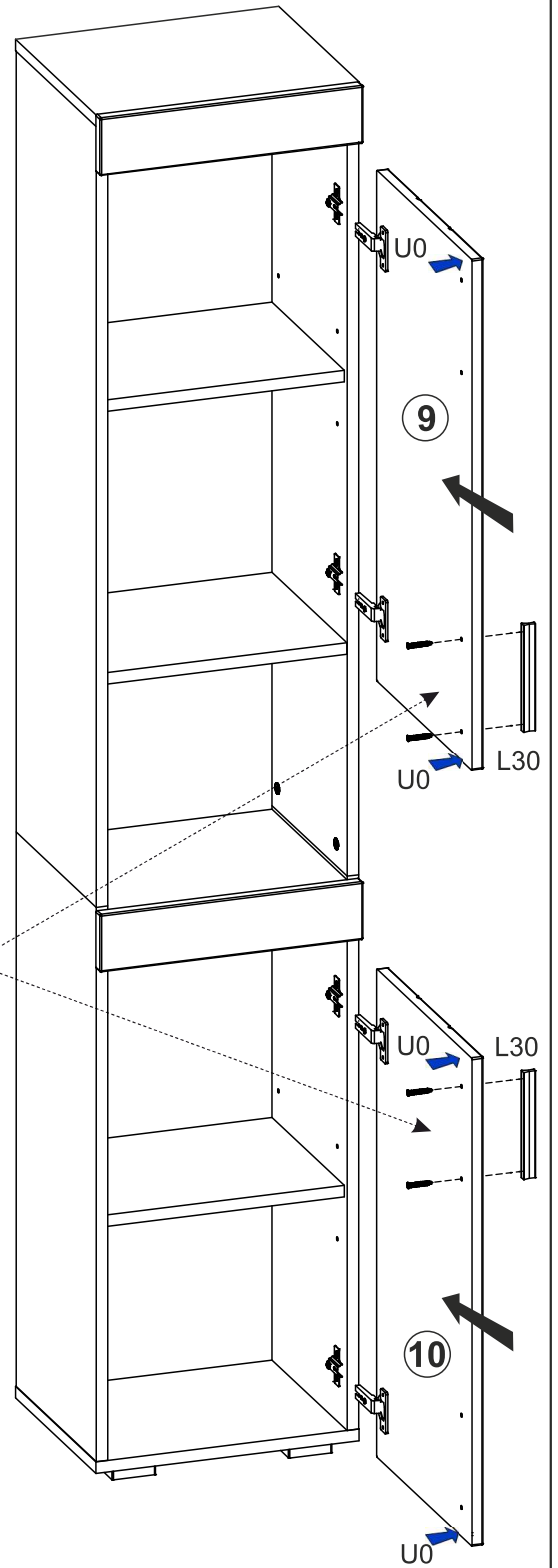
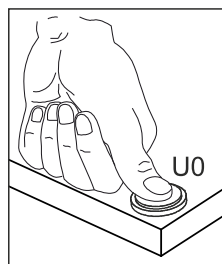
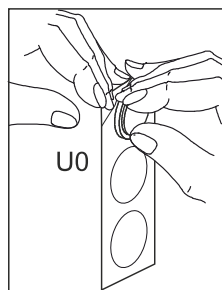
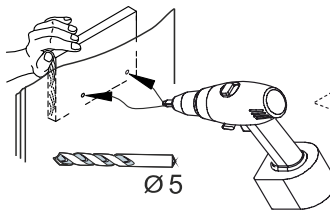
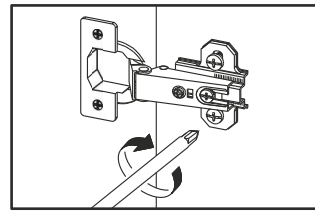
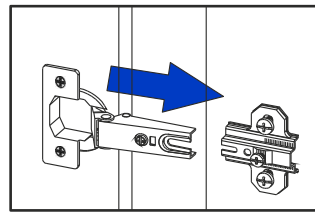
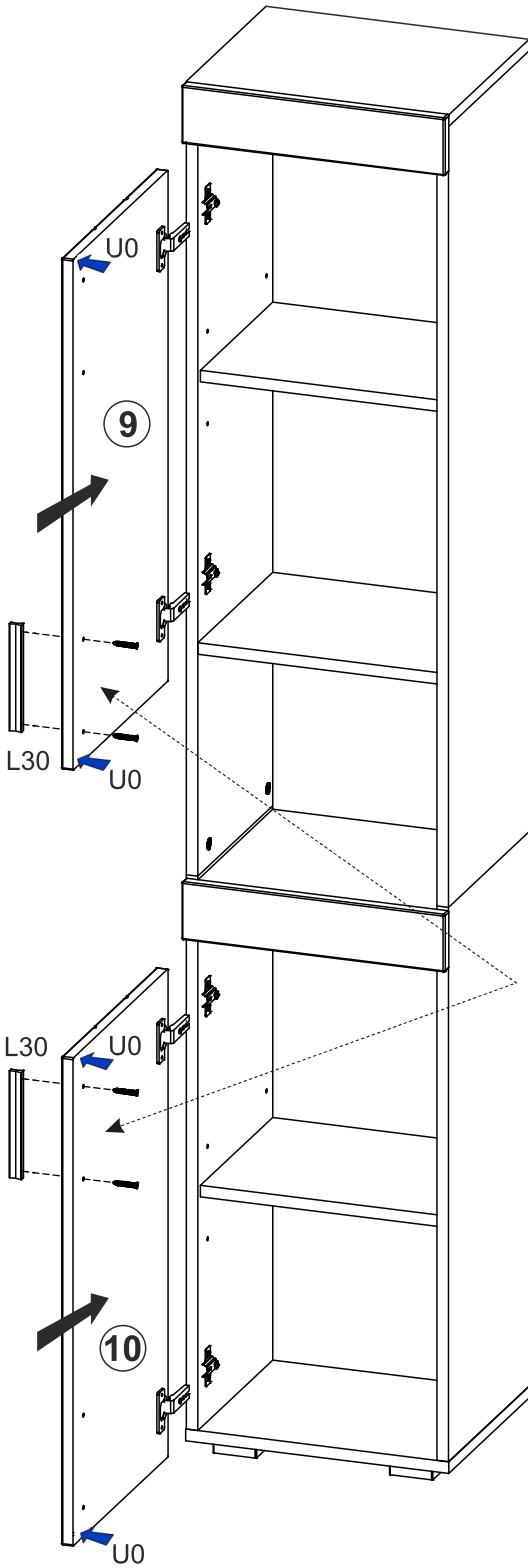
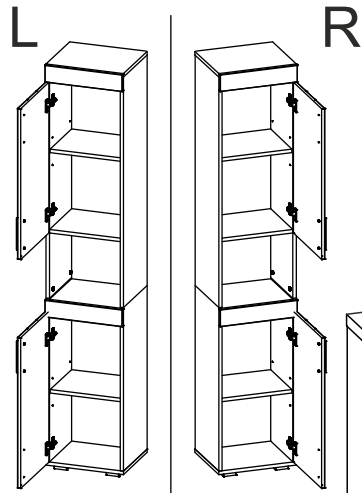
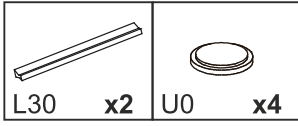

# 14

Ø5  
B54 x12

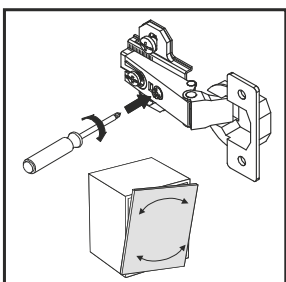
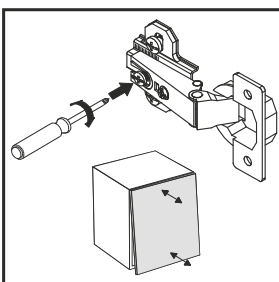
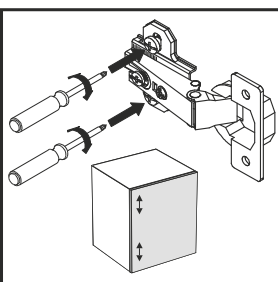
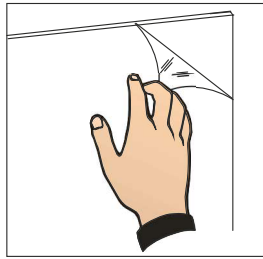
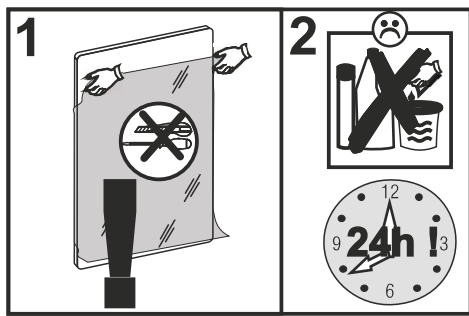
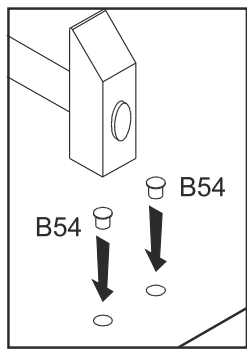
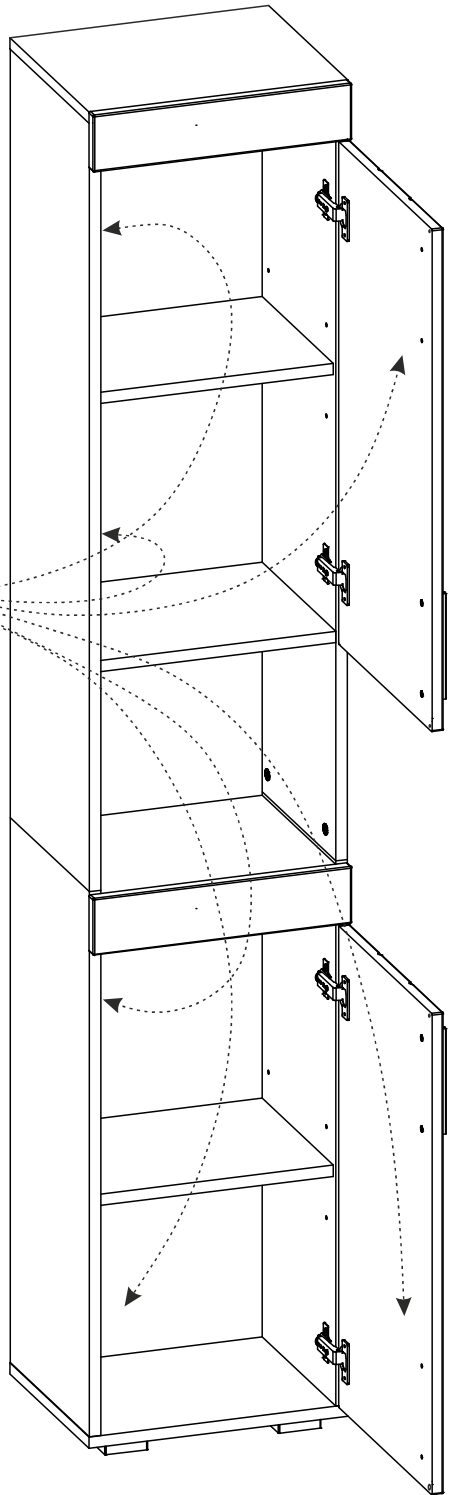
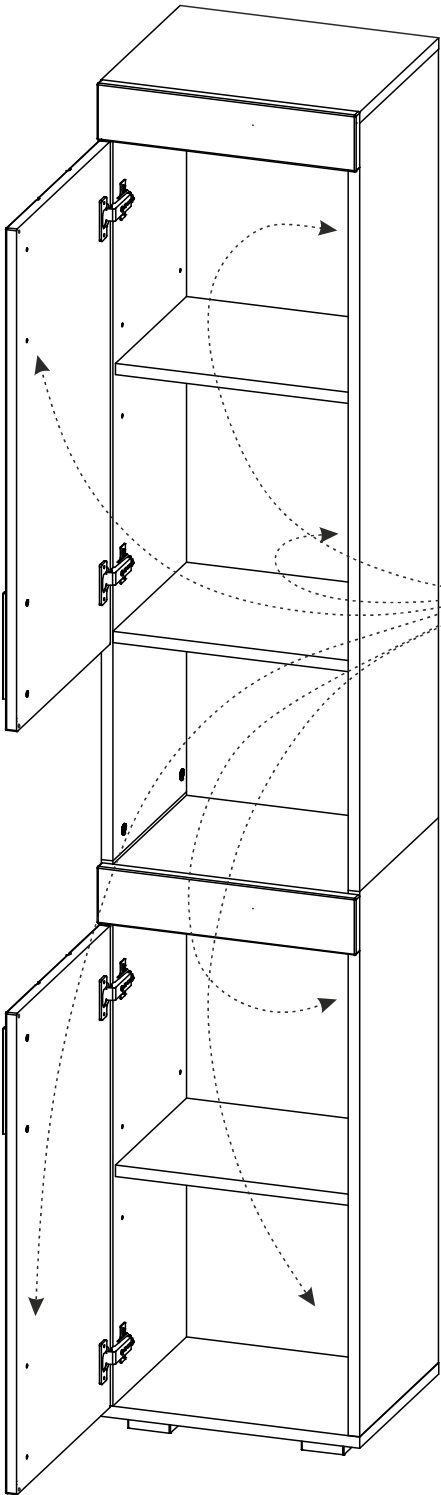
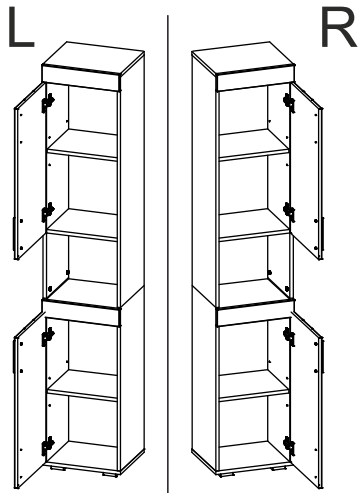

LKZ: X0105

Modellname / Model name / Nom du modèle / Modellnamn / Nome modello / Název modelu / Modelnaam / Ime modela / Numéro Modello / Modell neve / Название модели / Názov modelu / Ime modela / Denumire model / Наименование на модела / Nazwa modelu

**SNOW**

Modellnummer / Number / Numéro du modèle / Numero / Hoмер на модела / modello / Číslo modelu / Modell száma / Éíslo modelu / Številka modela / Număr model / Broj modela / Modelnummer / Numer modelu

**X19 A9 705**

Type / Tipo / Típus / Тип / Тип / Tip

**705**

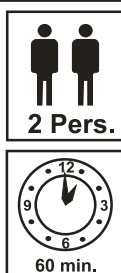
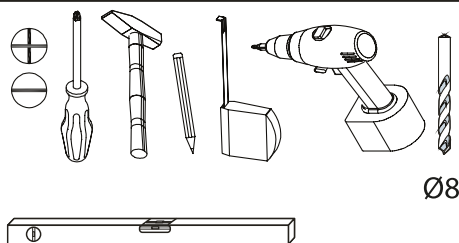
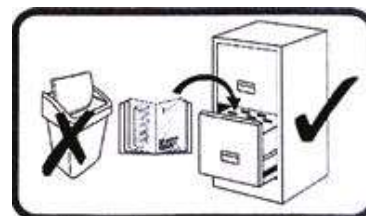
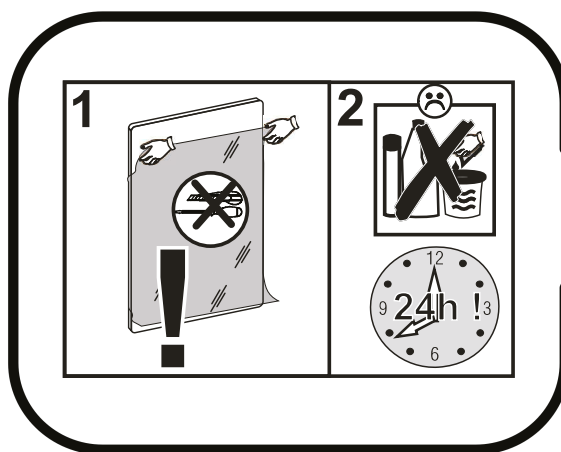
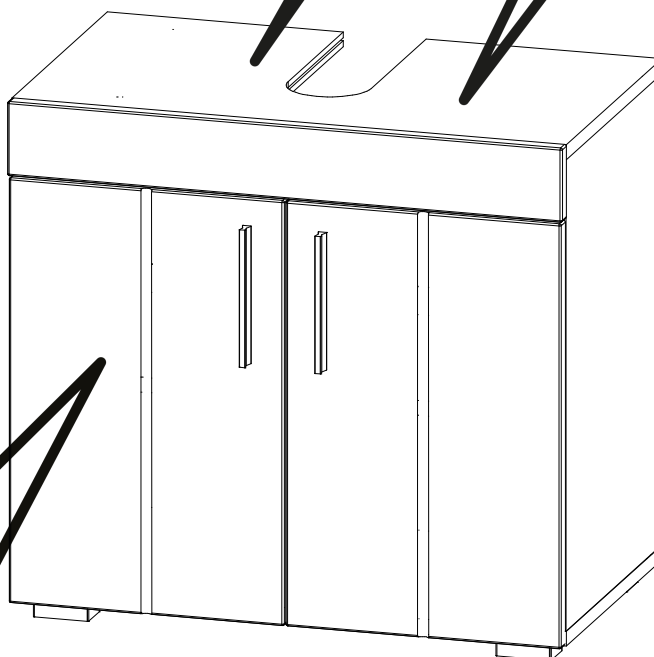
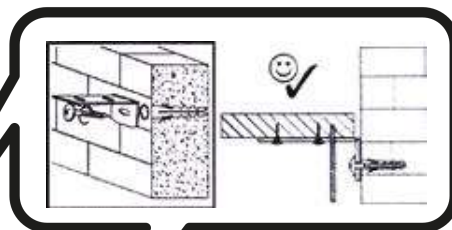
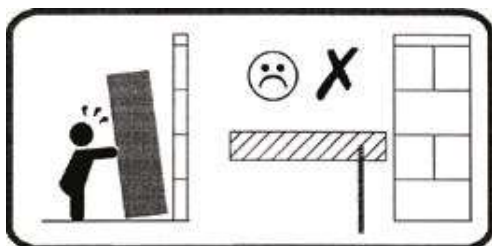
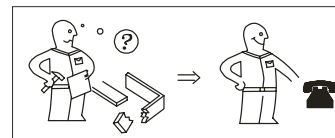
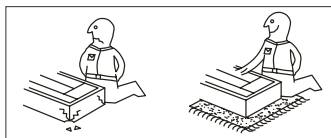
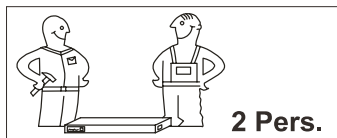

festziehen / tighten / Затягнете / serrer / stringere / utåhnut / vasttrekken / zategnuti / strångere / zwiázac / zacisnaç / szorosan meghúzni / revne dotiahnut / trdno pritegniti / затянуть / dra át



eindrücken / press in / enfoncer / wcisnaç / ribattere / zatlaçit / Вкарайте / indrukken / benyomni / stlaçit / vtisniti / tryck in / introducere prin arásare / вдавить



ausmessen / measure / mesurer / misurare / орметен / izmeriti / miara / kimérni / izmeriti / mäsurare / измерить / změřit / Измерете / mät upp / zmierzyc



drücken / press / presser / stisknout / Натиснете / vtisniti / nasinac / drukken / pritisnuti / nacisnac / pritisniti / нажать / (meg)nyomni / apasare / tryck fast / nacisnaç



einschlagen / hammer in / beverni / sla in / frapper au marteau / infossare / Zabit' / zarazit / Набийте / zabiti / wbiç / introducere prin bãtaie / забить / zatlaout



Drehen - wenden / przekreçic - odwróciç / Keren - omdraaien / Girare - Ruotare / Okrenuti - ubrnuti / Retourner - renverser / Turn over - turn around / Otoçte - obratite / Zavyrtete - obvyrtete / Obrnite list / Întoarçeți - rotiți / Vrid runt - vänd / прокрутить - повернуть / otoçit - obrátit / elforgatni - megfordítani

LKZ: XO105

Modellname / Model name / Nom du modèle / Modellnamn  
Nome modello / Název modelu / Modelnaam / Ime modela  
Número Modelo / Modell neve / Название модели /  
Názov modelu / Ime modelu / Denumire model /  
Наименование на модела / Nazwa modelu

**SNOW**

Modellnummer / Number / Numéro du modèle  
Numero / Номер на модела / modello  
Číslo modelu / Modell száma / Éíslo modelu  
Številka modela / Număr model / Broj modela  
Modelnummer / Numer modelu

**X19 A9 705**

Type / Tipo / Típus / Тип / Тип / Tip

**705**

**D**

Unser Direktservice für Beschlagteile

Sollte Ihnen ein Beschlagteil fehlen, können Sie diese Servicekarte direkt an die untenstehende Adresse mailen. Wir können allerdings nur Beschlagteile auf diesem Wege verschicken. Sollten Sie eine andere Beanstandung an Ihrem Möbelstück haben, so wenden sie sich bitte direkt an Ihr Möbelhaus.

Our direct order service for fitting

If a fitting part is missing, you can e-mail this service card directly to the address below. However, we can only send fitting parts in this way. If you have any other cause for complaint concerning your item of furniture, please contact your furniture store directly.

Naše přímé služby pro kování

Chybí-li vám nějaký díl z kování, můžete tuto servisní kartu odeslat e-mailem přímo na níže uvedenou adresu. Touto cestou však můžeme rozeslat jen díly kování. Pokud byste reklamovali jiný díl nábytku, obraťte se přímo na svého prodejce nábytku.

Bien étudier la notice de montage

S'il vous manque une ferrure, veuillez envoyer directement la présente carte service à l'adresse e-mail indiquée ci-dessous. Cependant, ceci nous permet uniquement d'envoyer des ferrures. Pour tout autre type de réclamation concernant votre meuble, veuillez contacter directement votre magasin d'ameublement.

**F**

Il nostro servizio diretto per l'ordine della ferramenta

Qualora Vi dovesse mancare un pezzo di fissaggio, allora Vi preghiamo di inviare questa carta di servizio immediatamente all'indirizzo sottostante. Possiamo inviare i pezzi di fissaggio solamente per mezzo di questo procedimento. Qualora dovete avere qualche altra reclamazione in merito al mobile, allora Vi preghiamo di rivolgerVi direttamente al Vostro Negozio di mobil.

**I**

Нашата директна услуга за обков

Ако липсват части от комплекта, попълнете настоящата сервисна карта и ни я изпратете на e-mail адреса, посочен по-долу. По този начин можем да доставяме само липсващи елементи от обкова. Ако установите други дефекти по мебелите, Ви съветваме да се обърнете към мебелната къща/магазин, от който сте закупили стоката.

**BG**

Onze directservice voor losse onderdelen

Wanneer er een onderdeel ontbreekt, kunt u deze servicekaart direct aan onderstaand e-mailadres sturen. Wij kunnen langs deze weg echter alleen beslagdelen versturen. Mocht u een ander probleem aan uw meubel hebben, verzoeken wij u contact op te nemen met uw meubeldealer.

**NL**

Nasz bezposredni serwis czesci montazowych

Jeżeli brakuje części koniecznych do montażu, prosimy o przesłanie nam niniejszej karty serwisowej na niżej podany adres e-mailowy. W ten sposób możemy przesłać Państwu tylko brakujące części. W przypadku innych reklamacji dotyczących mebla, prosimy zgłosić się do salonu meblowego, w którym został dokonany zakup.

**PL**

Servis za okove

U slučaju da nedostaje neki od dijelova molimo vas da na dolje navedenu mail adresu pošaljete ovaj servisni obrazac. Na ovaj način mogu se dostaviti samo okovi. U slučaju da imate dodatne prigovore vezane uz komad namještaja molimo vas da se obratite izravno trgovini namještaja gdje je isti kupljen.

**HR**

Direktszolgalatunk vasalatok esetén

Ha hiányzik egy vasalat, ezt a kártyát közvetlenül elküldheti az alább található címre. Azonban csakis vasalatokat tudunk így küldeni. Amennyiben másfajta reklamáció áll fenn bútordarabját illetően, forduljon közvetlenül a bútordáchoz.

**HU**

Náš priamy servis pre časti kovania

Ak by Vám chýbala nejaká časť kovania, môžete poslať túto servisnú kartu pošlat e-mailom na nižšie uvedené adresu. Díly kovania vieme poslať iba týmto spôsobom. Ak by ste mali inú reklamáciu ohľadom Vašho nábytku, obráťte sa priamo na Vašu predajňu nábytku.

**SK**

Naše direktne uslužne storitve za okovje

Ce vam manjka kakšno okovje, lahko to servisno kartico pošljete po e-pošti direktno na spodnji naslov. Po tej poti vam lahko pošljemo samo okovje. Če želite reklamirati kakšen drug del pohištva, se obrnite neposredno na vašo trgovino pohištva.

**SLO**

Service-ul nostru direct pentru feronerie

În cazul în care vă lipsește o piesă de feronerie puteți să trimiteti direct acest card de service prin e-mail la adresa de mai jos. Noi nu putem expedia piese de feronerie decât pe această cale. Dacă aveți o altă reclamație referitoare la piesa de mobilier, atunci vă rugăm să vă adresați direct la magazinul dvs. de mobilă.

**RO**

Наш прямой сервис для поставок фурнитуры

Если окажется, что Вам не хватает того или иного элемента фурнитуры, Вы можете отправить сервисную карту по факсу непосредственно на нижеприведенный адрес электронной почты. Однако, таким образом мы можем пересылать лишь фурнитуру. Если же у Вас возникнут иные претензии относительно приобретенной мебели, пожалуйста, обращайтесь непосредственно в организацию, осуществившую продажу.

**RUS**

Vår direktservice för beslagsdelar

Om du saknar en beslagsdel kan du skicka detta servicekort direkt till e-postadressen som anges nedan. Tänk på att detta är den enda möjligheten att skicka beslagsdelar till dig. Om du vill reklamera din möbel av en annan anledning måste du kontakta ditt möbelhus direkt.

**S**

Nuestro servicio directo para accesorios

Si le falta algún accesorio, puede enviar esta tarjeta de servicio directamente a la siguiente dirección. No obstante, por este método solo podemos enviar accesorios. Si tiene alguna otra objeción sobre su mueble, consulte directamente con su mueblería.

**ES**

Donatilar için doğrudan servisimiz

Bir donatınız eksikse bu servis kartını doğrudan aşağıda bulunan adrese doğrudan mail yazabilirsiniz. Sadece bu yöllä donatıları gönderebilirsiniz. Mobilyanız başka şikayetleriniz varsa lütfen doğrudan mobilya satıcınıza danışın.

**TR**

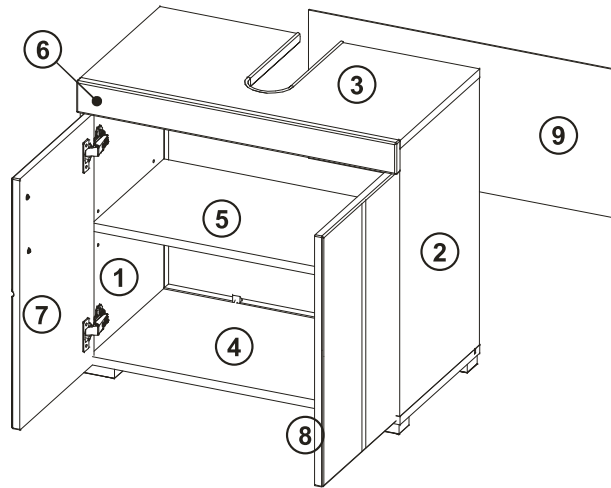

max.



max.



Nr.	Maße mm			Colli	Anzahl
1	508	338	16	1/1	1
2	508	338	16	1/1	1
3	601	338,5	16	1/1	1
4	601	338,5	16	1/1	1
5	568	308	16	1/1	1
6	601	80	16	1/1	1
7	458	298	16	1/1	1
8	458	298	16	1/1	1
9	578	265	2,5	1/1	1
B1				1/1	1

Grund der Beanstandung / Reason of the objection:

Möbelhaus / Furniture store:

Name / Name:

Telefon / Telephone:

PLZ / postal code:

Ort / City:

Strasse / Street:

Haus-Nr. / House No.:

@E-Mail:

E-Mail Kundenservice / Customer service e-mail / E-mail servisního střediska / E-mail de notre service clientèle / e-mail servizio clienti / E-mail на отделе за  
обслуживание на клиенті / E-mail klantenservice / E-mail serwisu dla klientów / Servisna mail adresa / Az ügyfélszolgálat e-mail címe / E-mail zákaznického  
servisu / E-pošta Servisna služba / E-mail Serviciu clienți / E-Mail сервисной службы / E-postadress kundservice / Servicio de atención por correo electrónico / Müşteri hizmetleri e-postası

service@xonox-home.com  
Hotline xonox.home GmbH  
0049-(0)5261-9220800

LKZ-XO105

Modellname / Model name / Nom du modèle / Modellnamn  
Nome modello / Název modelu / Modelnaam / Ime modela  
Número Modelo / Modell neve / Название модели /  
Názov modelu / Ime modela / Denumire model /  
Наименование на модела / Nazwa modelu











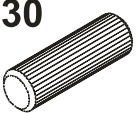
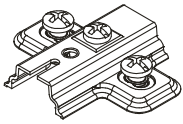
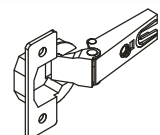

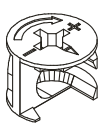
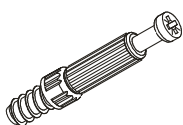

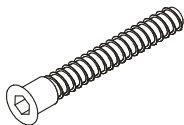
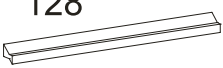
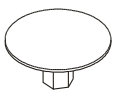
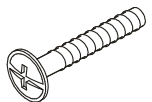
**SNOW**

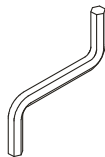
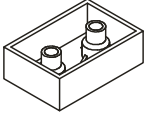
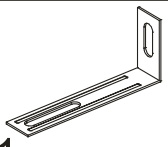
Modellnummer / Number / Numéro du modèle  
Numero / Номер на модела / modello  
Číslo modelu / Modell száma / Ěíslo modelu  
Številka modela / Număr model / Broj modela  
Modelnummer / Numer modelu

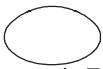





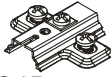

**X19 A9 705**

Type / Tipo / Tipus / Тип / Тип / Tip

**705**

<b>8x30</b>  <b>A0</b> x8	 <b>G1B</b> x4	 <b>G1A</b> x4	<b>4 x 16 mm</b>  <b>D10</b> x8	 <b>H0</b> x4	<b>B1</b>
 <b>C1</b> x4	 <b>C2</b> x4	 <b>B0</b> x4	 <b>B1</b> x4	<b>128</b>  <b>L30</b> x2	 <b>C0</b> x4
<b>4x25</b>  <b>D18</b> x4	<b>4x20</b>  <b>D14</b> x8	<b>3,5x16</b>  <b>D17</b> x12	 <b>Z</b> x1	 <b>T1</b> x4	 <b>I1</b> x2
 <b>F0</b> x7	 <b>1,5mm</b> <b>U0</b> x2	<b>3x15</b>  <b>D0</b> x7	  <b>E2</b> x2	 <b>U3</b> x1	 <b>F1</b> x2

1

 A0 x8	 G1B x4	 H0 x4	 C1 x4	 C2 x4
 D14 x8	 D17 x4	 T1 x4	 F1 x2	

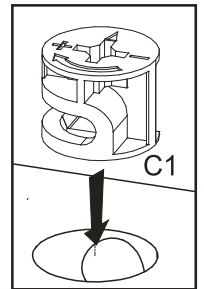
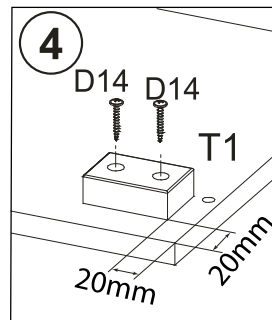
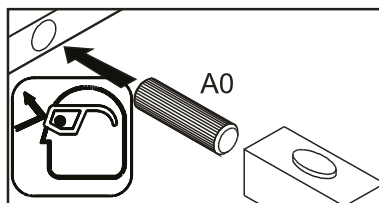
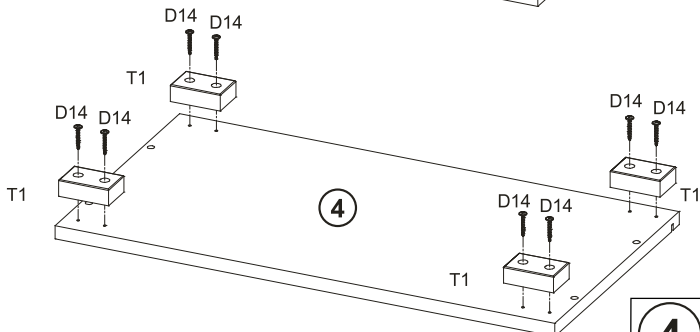
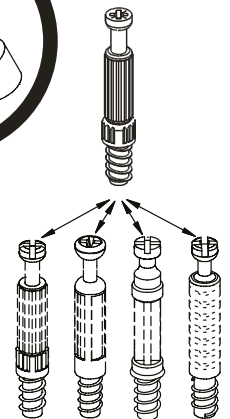
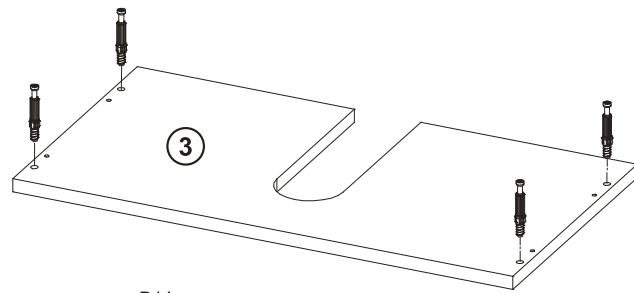
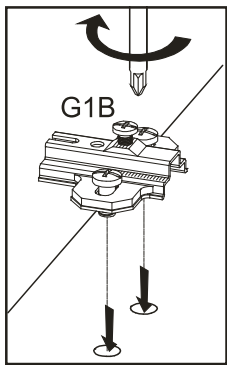
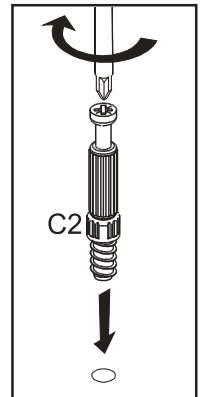
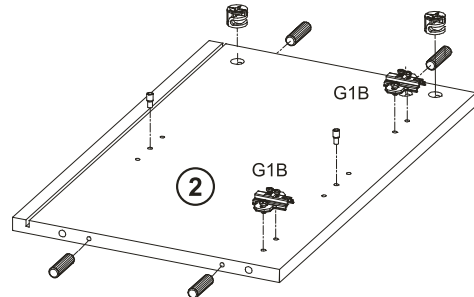
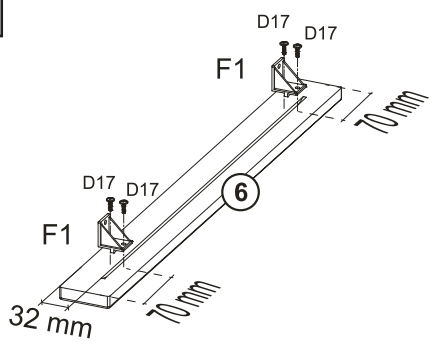
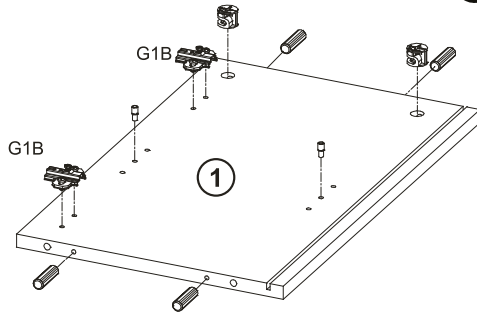
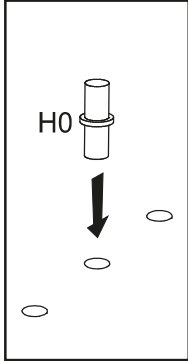
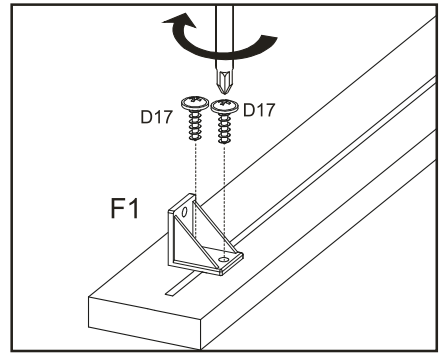



2

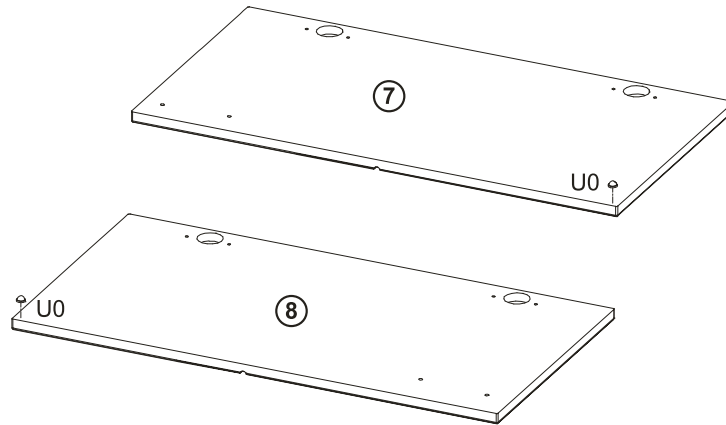
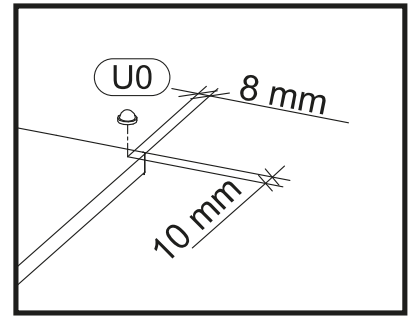
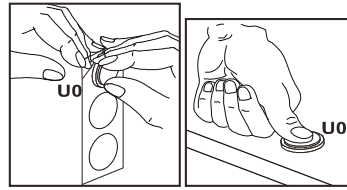
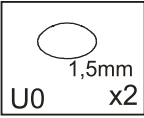

3

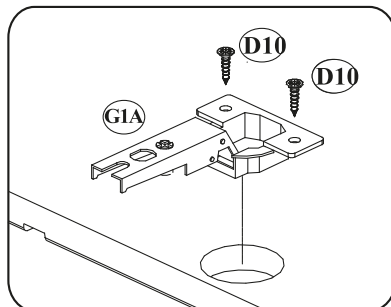
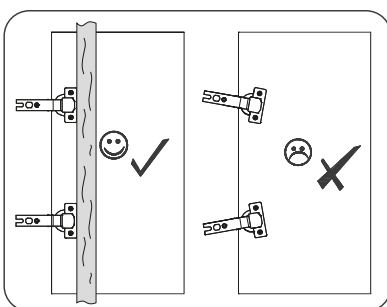
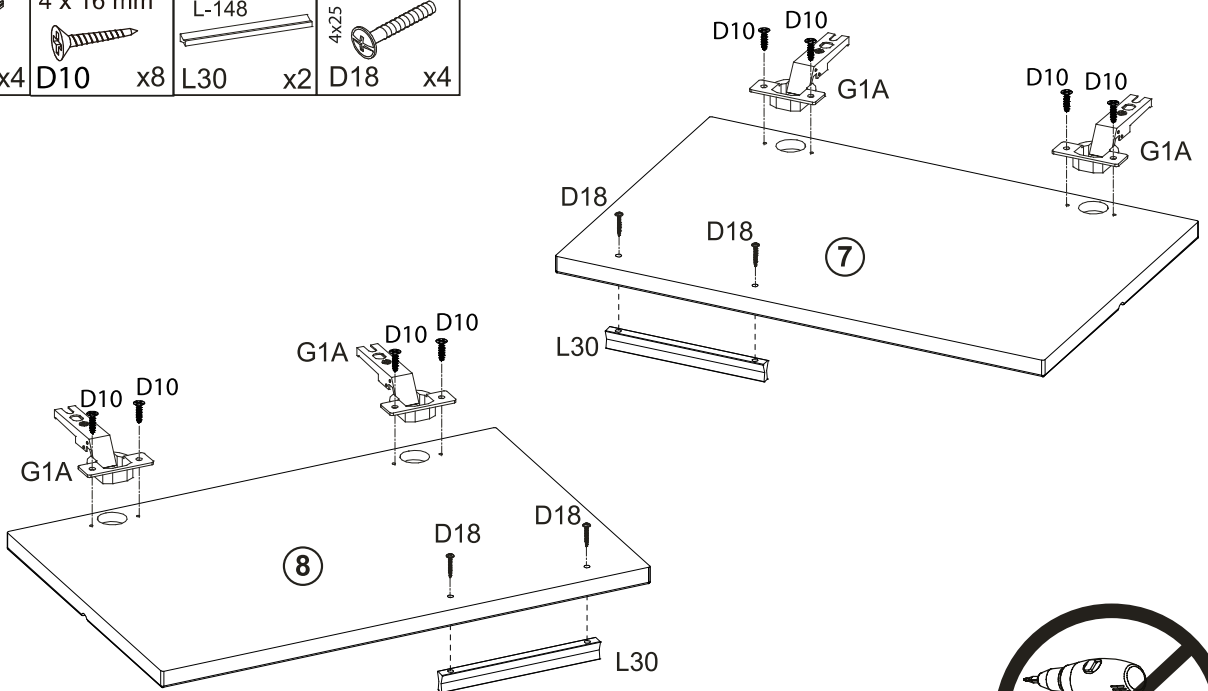
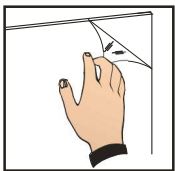
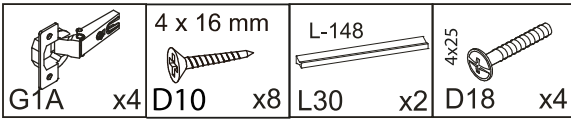

4

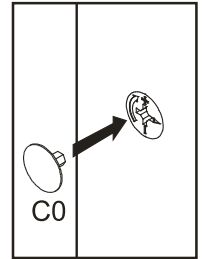
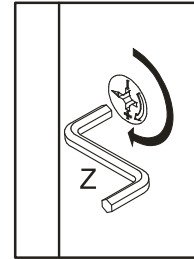
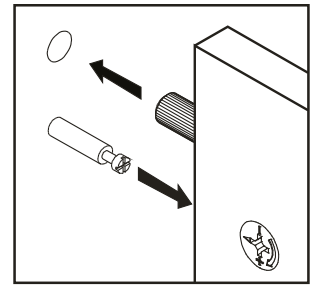
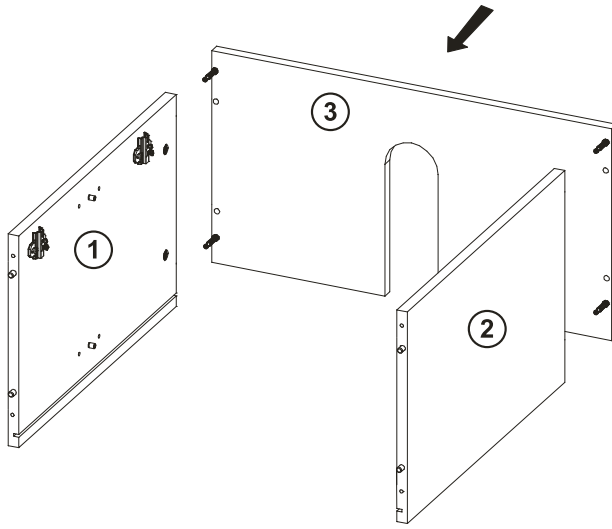
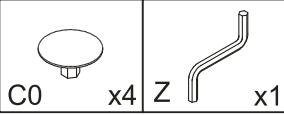

5

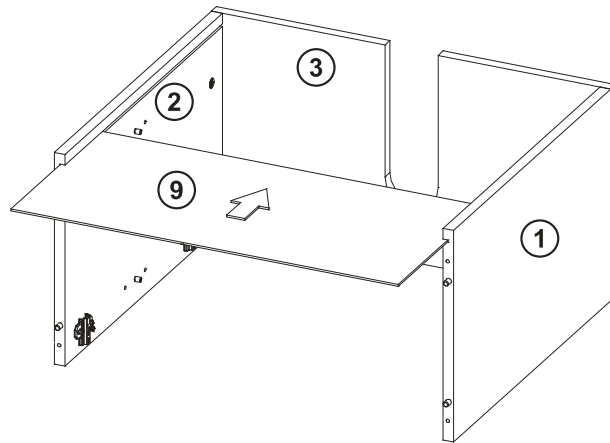

6

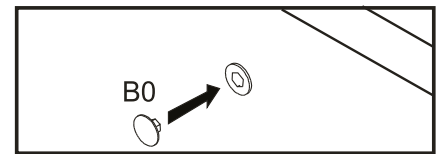
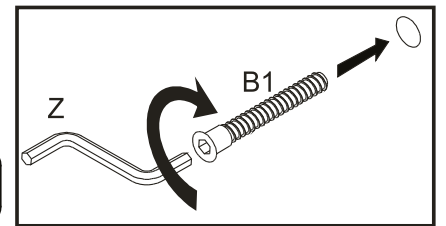
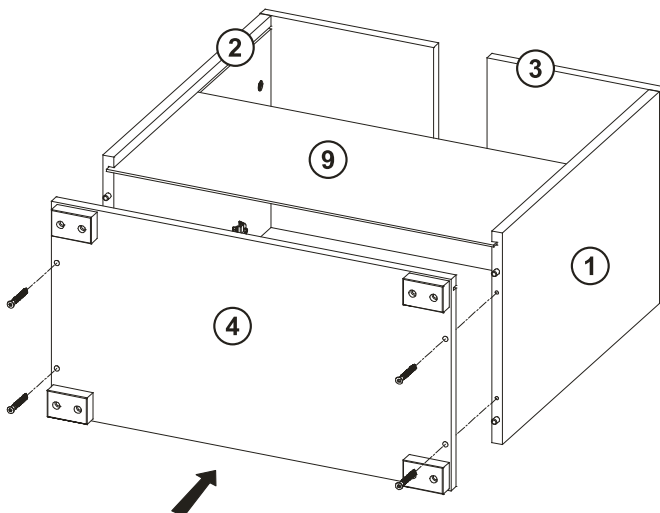
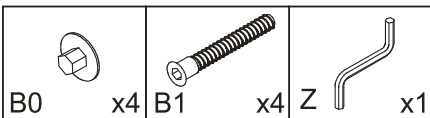

7

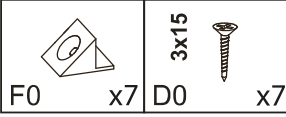

A=B

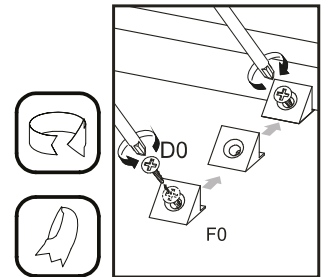
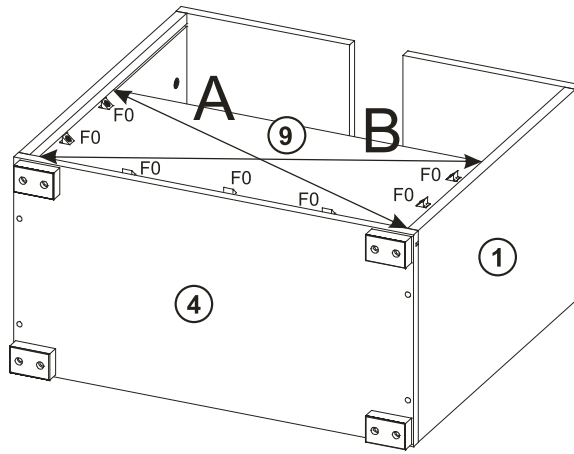

8

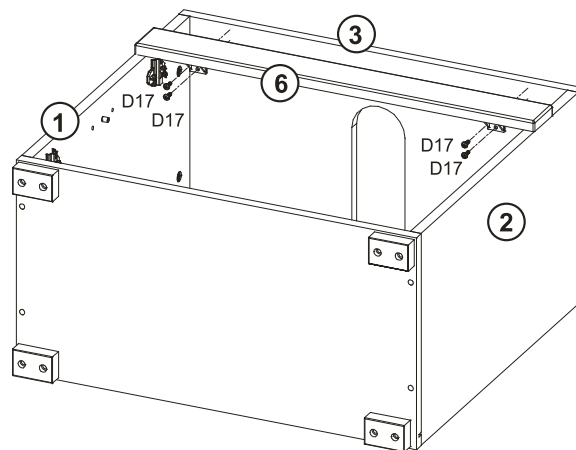
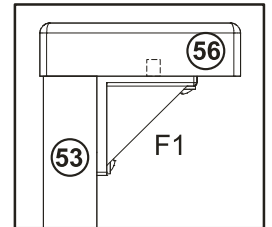
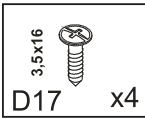

9

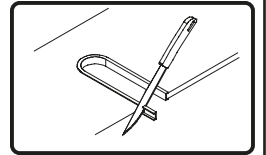
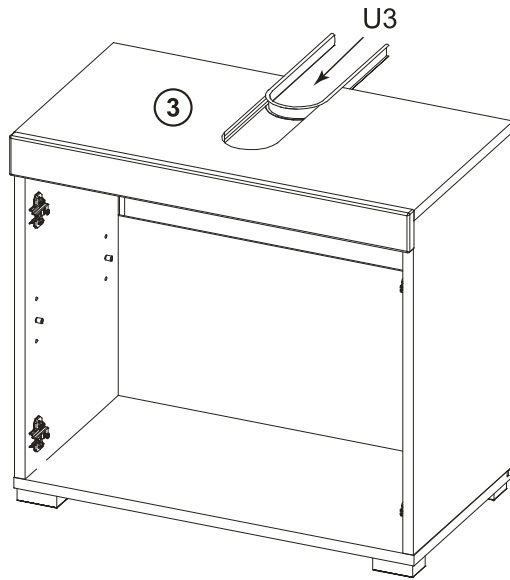
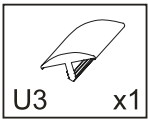

10

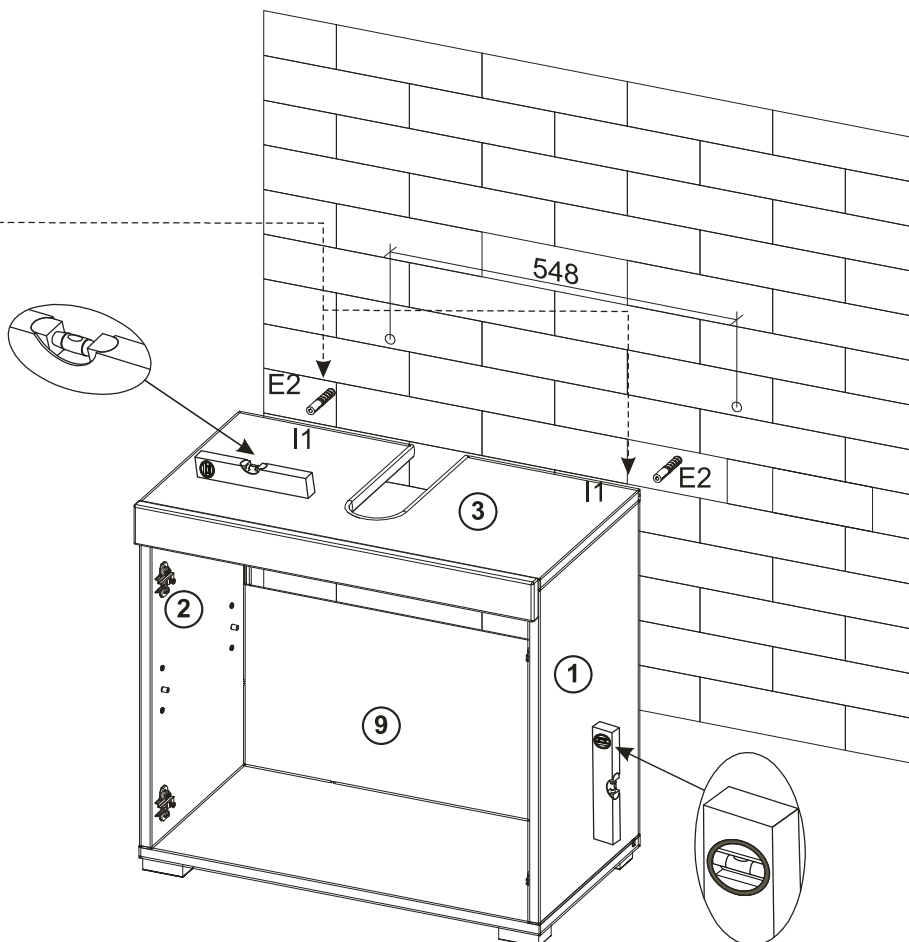
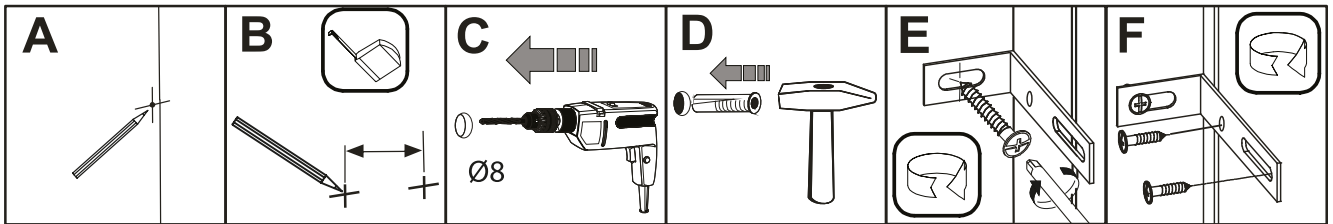
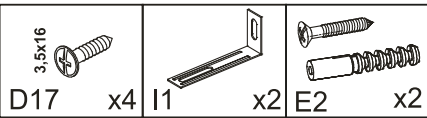

11

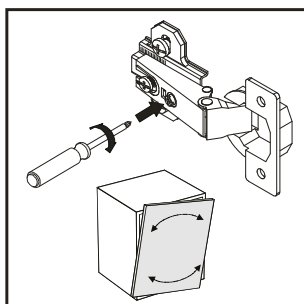
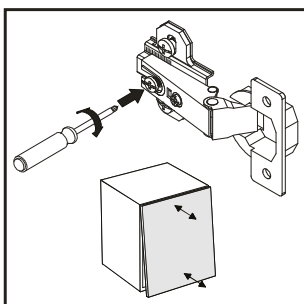
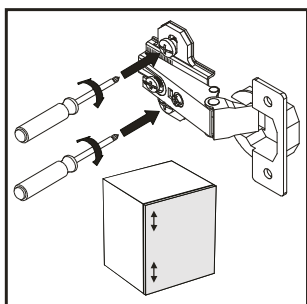
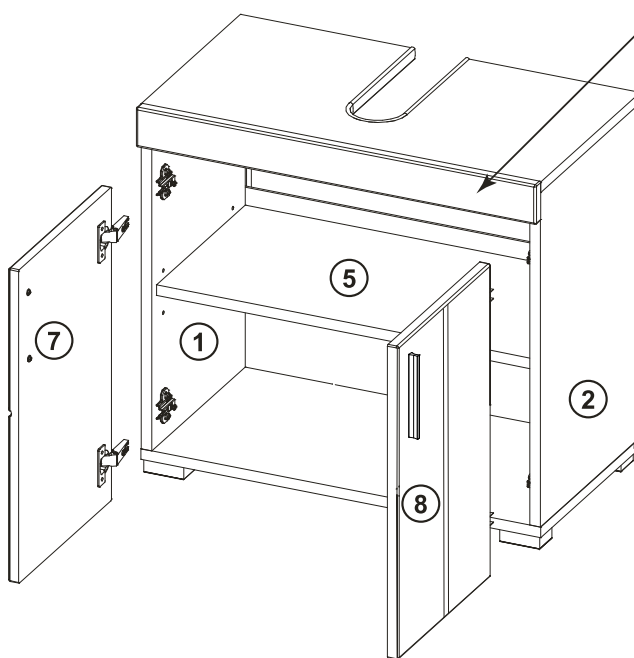
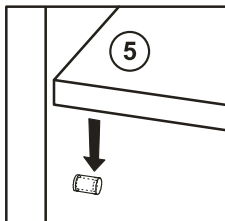
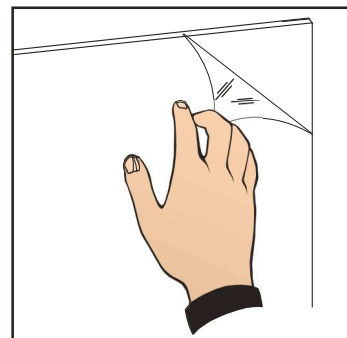
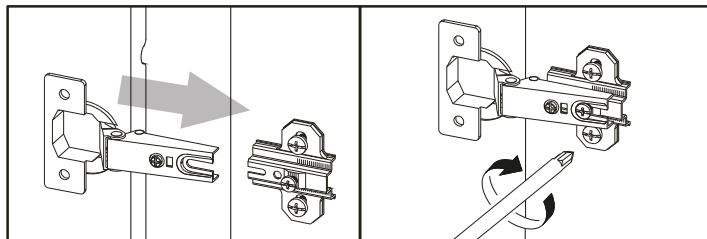

LKZ: X0105

Modellname / Model name / Nom du modèle / Modellnamn  
 Nome modello / Název modelu / Modelnaam / Ime modela  
 Numéro Modelo / Modell neve / Название модели /  
 Názov modelu / Ime modela / Denumire model /  
 Наименование на модела / Nazwa modelu

**SNOW**

Modellnummer / Number / Numéro du modèle  
 Numero / Homep на модела / modello  
 Číslo modelu / Modell száma / Ěíslo modelu  
 Številka modela / Număr model / Broj modela  
 Modelnummer / Numer modelu

**X19 A9 725**

Type / Tipo / Típus / Typ / Тип / Tip

**725**

25.10.2021

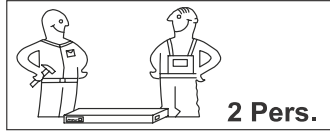
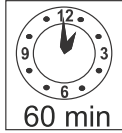

**2 Pers.**

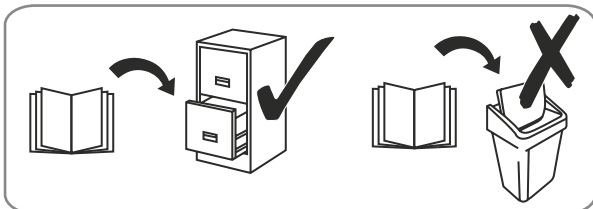
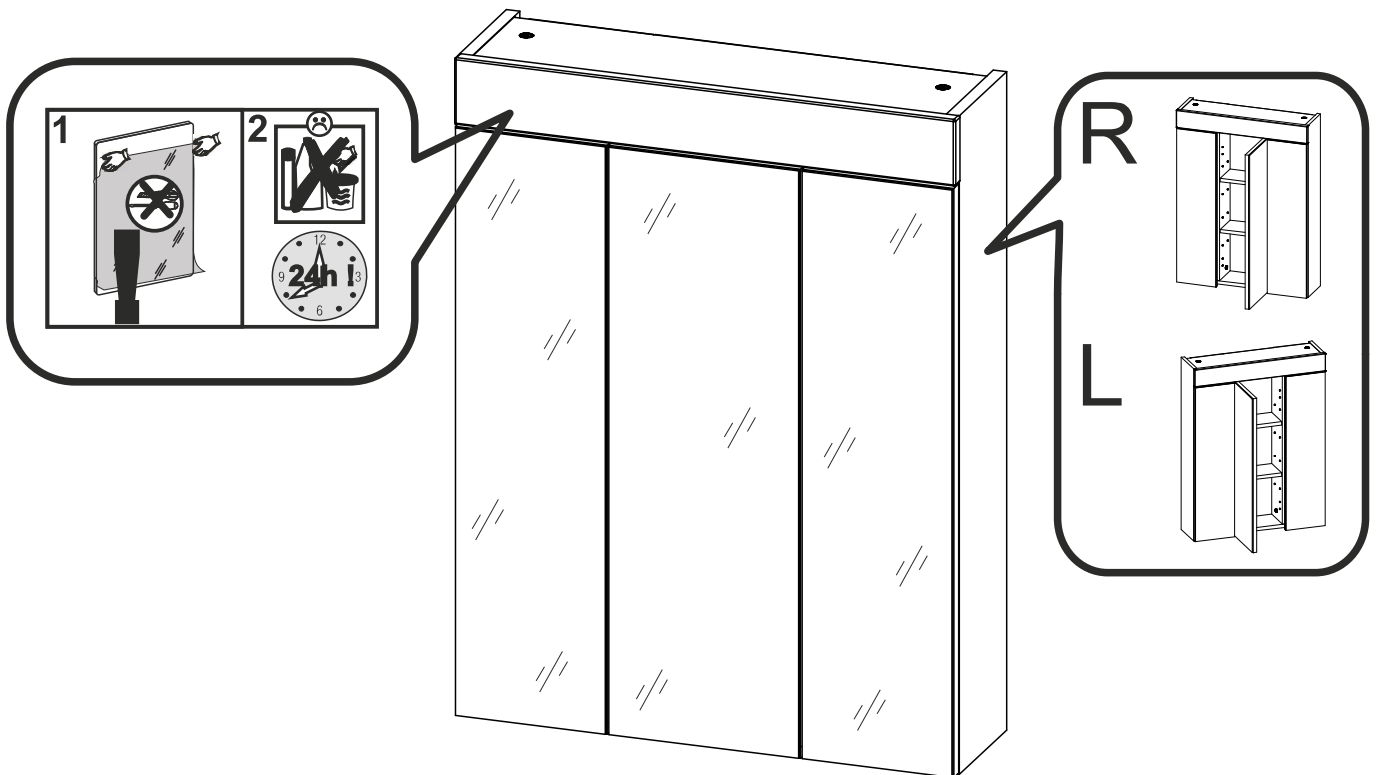
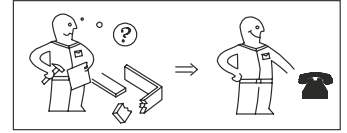
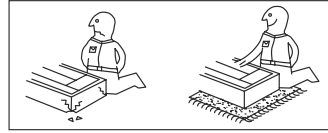

**Wichtig - Für spätere Verwendung  
 aufbewahren - sorgfältig lesen!**

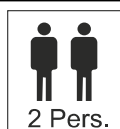
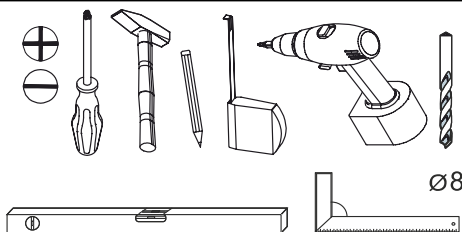

**2 Pers.**

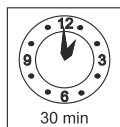

festziehen / tighten / Затягивать /  
 serrer / stringere / utåhntout / vasttrekken /  
 zategnuti / strångere / zwiázac / zacisnąć  
 szorosan meghúzni / pevne dotiahnut /  
 trdno pritegniti / затянуть / dra át



eindrücken / press in / enfoncer / wcisnąć  
 ribattere / zatlačit / Вкчайте / Indrukken  
 benyomni / silacci / vtisniti / tryck in  
 introducere prin apăşare / вдавить



ausmessen / measure / mesurer /  
 misurare / ometen / izmeriti / miara /  
 kimérni / izmeriti / măsurare / измерить  
 změřit / Измерете / mät upp / zmierzyc



drücken / press / presser / stisknout /  
 Натиснете / vtisniti / nasinac / drukken /  
 pritisniti / nacisnac / pritisniti / нажать /  
 (meg)nyomni / apăşare / tryck fast / nacisnąć



einschlagen / hammer in / beverni / slå in  
 frapper au marteau / infossare / Zabit' /  
 zarazit / Набийте / zabiti / wbić  
 introduce prin bătaie / забить / załouct



Drehen - wenden / przekręcić - odwrócić /  
 Keren - omdraaien / Girare - Ruotare /  
 Okrenuti - ubnuti / Retourner - renverser /  
 Turn over - turn around / Otocte - obratle /  
 Zavyřrete - obvyřete / Obrnite list /  
 Înţoarceţi - roţiţi / Vrid runt - vänd /  
 прокрутить - повернуть / otócit - obrátit  
 elforgatni - megfordítani

LKZ: X0105

Modellname / Model name / Nom du modèle / Modellnamn  
Nome modello / Název modelu / Modelnaam / Ime modela  
Número Modelo / Modell neve / Название модели /  
Názov modelu / Ime modela / Denumire model /  
Наименование на модела / Nazwa modelu

**SNOW**

Modellnummer / Number / Numéro du modèle  
Numero / Номер на модела / modello  
Číslo modelu / Modell száma / Ěíslo modelu  
Številka modela / Numár model / Broj modela  
Modelnummer / Numer modelu

**X19 A9 725**

Type / Tipo / Típus / Typ / Тип / Tip

**725**

25.10.2021

**D** Unser Direktservice für Beschlagteile  
Sollte Ihnen ein Beschlagteil fehlen, können Sie diese Servicekarte direkt an die untenstehende Adresse mailen. Wir können allerdings nur Beschlagteile auf diesem Wege verschicken. Sollten Sie eine andere Beanstandung an Ihrem Möbelstück haben, so wenden Sie sich bitte direkt an Ihr Möbelhaus.

**GB** Our direct order service for fitting  
If a fitting part is missing, you can e-mail this service card directly to the address below. However, we can only send fitting parts in this way. If you have any other cause for complaint concerning your item of furniture, please contact your furniture store directly.

**CZ** Naše přímé služby pro kování  
Chybí-li vám nějaký díl z kování, můžete tuto servisní kartu odeslat e-mailem přímo na níže uvedenou adresu. Touto cestou však můžeme zoslat jen díly kování. Pokud byste reklamovali jiný díl nábytku, obraťte se přímo na svého prodejce nábytku.

**F** Bien étudier la notice de montage  
S'il vous manque une ferrure, veuillez envoyer directement la présente carte service à l'adresse e-mail indiquée ci-dessous. Cependant, ceci nous permet uniquement d'envoyer des ferrures. Pour tout autre type de réclamation concernant votre meuble, veuillez contacter directement votre magasin d'ameublement.

**I** Il nostro servizio diretto per l'ordine della ferramenta  
Qualora Vi dovesse mancare un pezzo di fissaggio, allora Vi preghiamo di inviare questa carta di servizio immediatamente all'indirizzo sottostante. Possiamo inviare i pezzi di fissaggio solamente per mezzo di questo procedimento. Qualora dovete avere qualche altra reclamazione in merito al mobile, allora Vi preghiamo di rivolgerVi direttamente al Vostro Negozio di mobili.

**BG** Нашата директна услуга за обков  
Ако липсват части от комплекта, попълнете настоящата сервисна карта и ни я изпратете на e-mail адреса, посочен по-долу. По този начин можем да доставяме само липсващи елементи от обкова. Ако установите други дефекти по мебелите, Ви съветваме да се обърнете към мебелната къща/магазин, от който сте закупили стоката.

**NL** Onze directservice voor losse onderdelen  
Wanneer er een onderdeel ontbreekt, kunt u deze servicekaart direct aan ons toesturend e-mailadres sturen. Wij kunnen langs deze weg echter alleen beslagdelen versturen. Mocht u een ander probleem aan uw meubel hebben, verzoeken wij u contact op te nemen met uw meubeldealer.

**PL** Nasz bezpośredni serwis czeski montażowy  
Jeżeli brakuje części koniecznych do montażu, prosimy o przesłanie nam niniejszej karty serwisowej na niżej podany adres e-mailowy. W ten sposób możemy przelać Państwu tylko brakujące części. W przypadku innych reklamacji dotyczących mebla, prosimy zgłosić się do salonu meblowego, w którym został dokonany zakup.

**HR** Servis za okove  
U slučaju da nedostaje neki od dijelova molimo vas da na dolje navedenu mail adresu pošaljete ovaj servisni obrazac. Na ovaj način mogu se dostaviti samo okovi. U slučaju da imate dodatne prigovore vezane uz komad namještaja molimo vas da se obratite izravno trgovini namještaja gdje je isti kupljen.

**HU** Direktszolgáltatunk vasalatok esetén  
Ha hiányzik egy vasalat, ezt a kártyát közvetlenül elküldheti az alább található címre. Azonban csakis vasalatoskat tudunk így küldeni. Amennyiben másfajta reklamáció áll fenn bútordarabját illetően, forduljon közvetlenül a bútortárházhoz.

**SK** Naš priamy servis pre časti kovania  
Ak by Vám chýbala nejaká časť kovania, môžete poslať túto servisnú kartu poslať e-mailom na nižšie uvedenú adresu. Diely kovania vieme poslať iba týmto spôsobom. Ak by ste mali inú reklamáciu ohľadom Vašho nábytku, obraťte sa priamo na Vašu predajňu nábytku.

**SLO** Naše direktno uslužne storitve za okovje  
Če vam manjka kakšno okovje, lahko to servisno kartico pošljete po e-pošti direktno na spodnji naslov. Po tej poti vam lahko pošljemo samo okovje. Če želite reklamirati kakšen drug del pohištva, se obmite neposredno na vašo trgovino pohištva.

**RO** Service-ul nostru direct pentru feronerie  
În cazul în care vă lipsește o piesă de feronerie puteți să trimiteți direct acest card de service prin e-mail la adresa de mai jos. Noi nu putem expedia piese de feronerie decât pe această cale. Dacă aveți o altă reclamație referitoare la piesa de mobilier, atunci vă rugăm să vă adresați direct la magazinul dvs. de mobilă.

**RUS** Наш прямой сервис для поставок фурнитуры  
Если окажется, что Вам не хватает того или иного элемента фурнитуры, Вы можете отправить сервисную карту по факсу непосредственно на нижеприведенный адрес электронной почты. Однако, таким образом мы можем переслать лишь фурнитуру. Если же у Вас возникнут иные претензии относительно приобретенной мебели, пожалуйста, обращайтесь непосредственно в организацию, осуществившую продажу.

**S** Vår direktservice för beslagsdelar  
Om du saknar en beslagsdel kan du skicka detta servicekort direkt till e-postadressen som anges nedan. Tänk på att detta är den enda möjligheten att skicka beslagsdelar till dig. Om du vill reklamera din möbel av en annan anledning måste du kontakta ditt möbelhus direkt.

**ES** Nuestro servicio directo para accesorios  
Si le falta algún accesorio, puede enviar esta tarjeta de servicio directamente a la siguiente dirección. No obstante, por este método solo podemos enviar accesorios. Si tiene alguna otra objeción sobre su mueble, consulte directamente con su mueblería.

**TR** Donatılar için doğrudan servisimiz  
Bir donatınız eksikse bu servis kartını doğrudan aşağıda bulunan adrese doğrudan mail yazabilirsiniz. Sadece bu yolla donatıları gönderebiliriz. Mobilyanızda başka şikayetleriniz varsa lütfen doğrudan mobilya satıcınıza danışın.



= 5 6 7

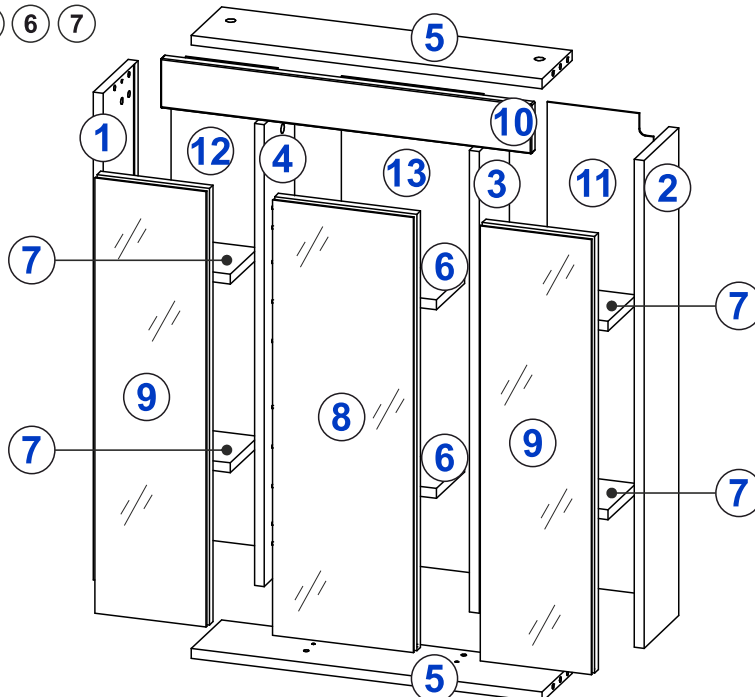

Nr.	Maße mm			Colli	Anzahl
1	790	155	16	1/1	1
2	790	155	16	1/1	1
3	748	134	16	1/1	1
4	748	134	16	1/1	1
5	568	134,5	16	1/1	2
6	216	125	16	1/1	2
7	160	125	16	1/1	4
8	707	230	20	1/1	1
9	707	182	20	1/1	2
10	80	601	16	1/1	1
11	778	172	2,5	1/1	1
12	778	172	2,5	1/1	1
13	778	230	2,5	1/1	1
B1				1/1	1

Grund der Beanstandung / Reason of the objection:

Möbelhaus / Furniture store:

Name / Name: Telefon / Telephone:

PLZ / postal code: Ort / City:

Strasse / Street:

Haus-Nr. / House No.: @E-Mail:

E-Mail Kundenservice / Customer service e-mail / E-mail servisního střediska / E-mail de notre service clientèle / e-mail servizio clienti / E-mail на отдела за обслужване на клиенти / E-mail klantenservice / E-mail servisu dla klientów / Servisna mail adresa / Az ügyfélszolgálat e-mail címe / E-mail zákaznického servisu / E-pošta Servisna služba / E-mail Serviciu clienți / E-Mail сервисной службы / E-postadress kundservice / Servicio de atención por correo electrónico / Müşteri hizmetleri e-postası

service@xonox-home.com  
Hotline xonox.home GmBH  
0049-(0)5261-92020800

LKZ: X0105

Modellname / Model name / Nom du modèle / Modellnamn  
Nome modello / Název modelu / Modelnaam / Ime modela  
Número Modelo / Modell neve / Название модели /  
Názov modelu / Ime modela / Denumire model /  
Наименование на модела / Nazwa modelu

**SNOW**

Modellnummer / Number / Numéro du modèle  
Numero / Номер на модела / modello  
Číslo modelu / Modell száma / Ěíslo modelu  
Številka modela / Număr model / Broj modela  
Modelnummer / Numer modelu















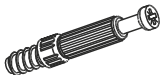

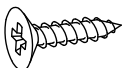
**X19 A9 725**

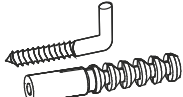
Type / Tipo / Típus / Тип / Тип / Tip

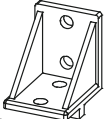
**725**



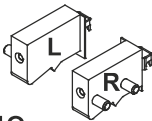



25.10.2021

# B1

<p>Ø8x30</p>  <p><b>A0 x16</b></p>	<p>Ø5</p>  <p><b>B54 x4</b></p>	 <p><b>C0 x8</b></p>	 <p><b>C1 x8</b></p>	 <p><b>C2 x8</b></p>	<p>3x15</p>  <p><b>D0 x6</b></p>
<p>4x16</p>  <p><b>D10 x12</b></p>	<p>3,5x16</p>  <p><b>D17 x26</b></p>	 <p><b>E2 x2</b></p>	 <p><b>F0 x6</b></p>	 <p><b>F1 x2</b></p>	 <p><b>F10 x6</b></p>
 <p><b>G1B x6</b></p>	 <p><b>G3A x6</b></p>	 <p><b>H0 x24</b></p>	 <p><b>M3 x1</b></p>	 <p><b>U0 x6</b></p>	

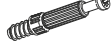





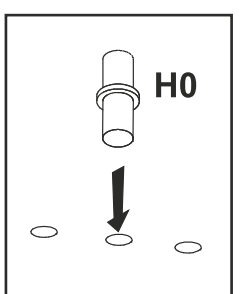
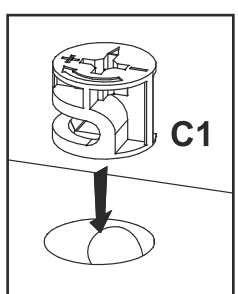
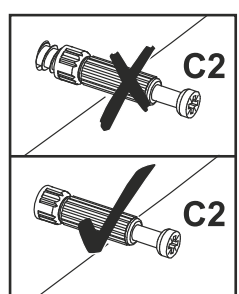
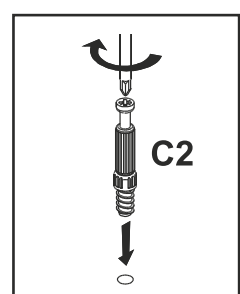
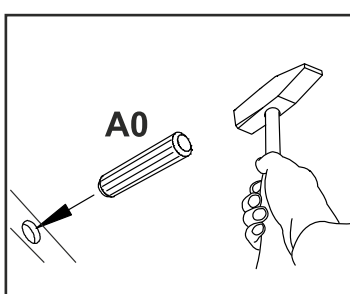
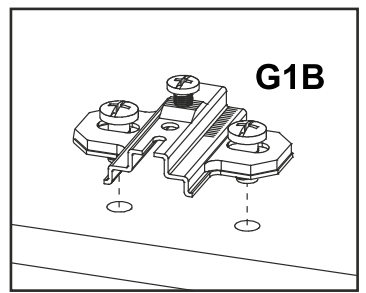
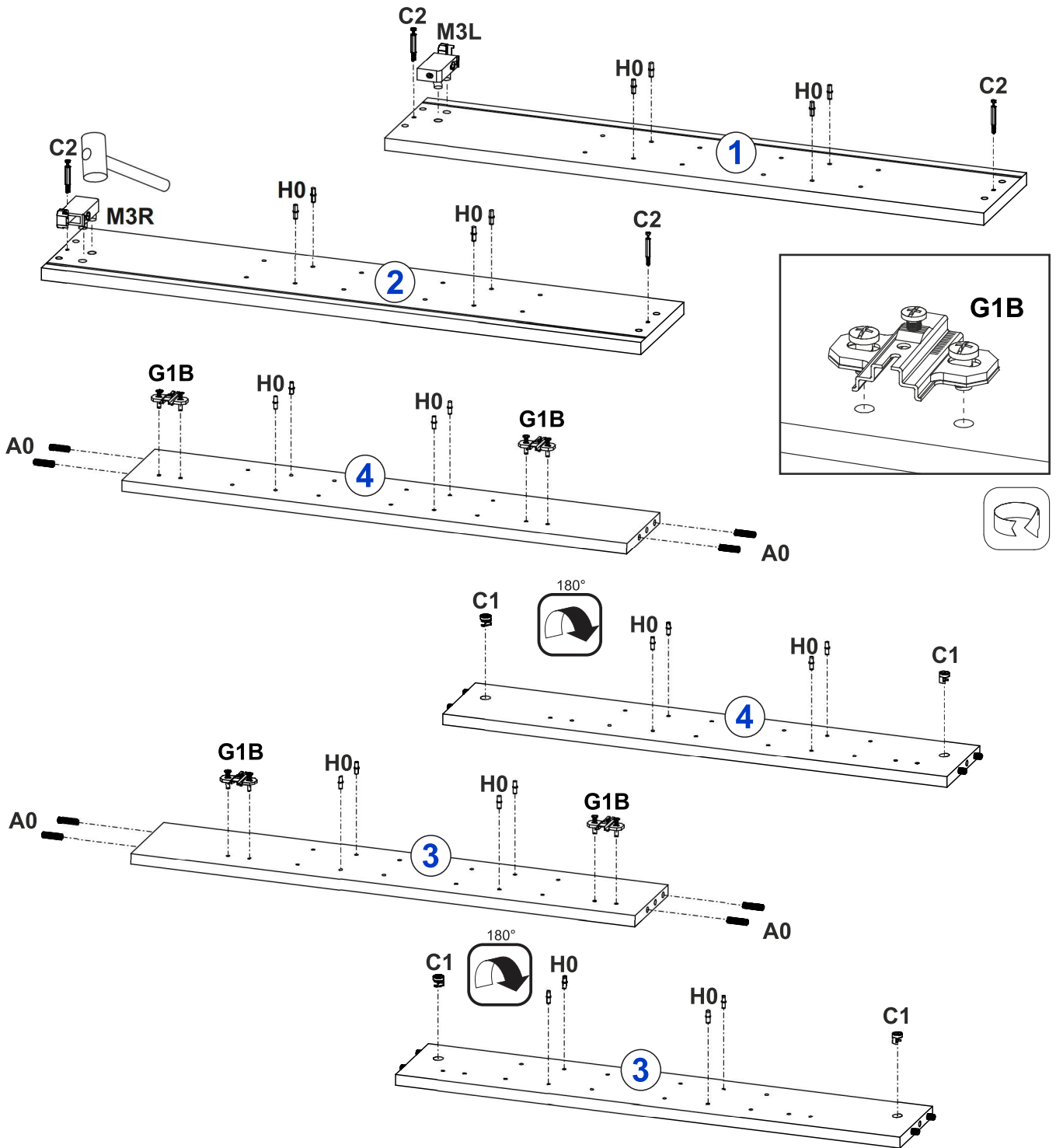
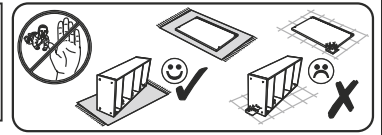

# 1

 A0 x8	 C1 x4	 C2 x4	 G1B x4	 H0 x24	 M3 x1
--	--	--	---	---	---

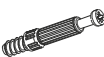

# 2

 Ø8x30 A0 x8	 C1 x4	 C2 x4	 4x16 D10 x12	 3,5x16 D17 x4	 F1 x2	 G3A x6
---	--	--	--	---	--	---

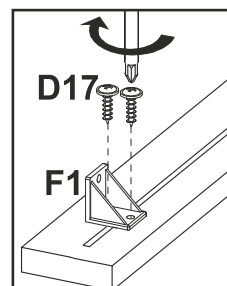
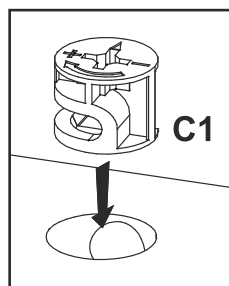
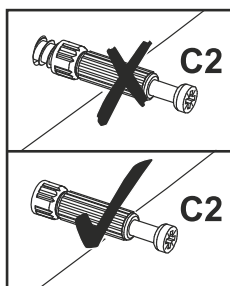
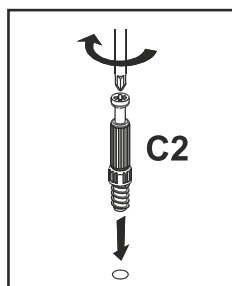
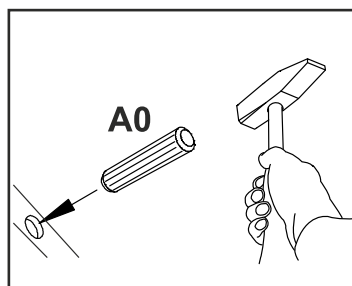
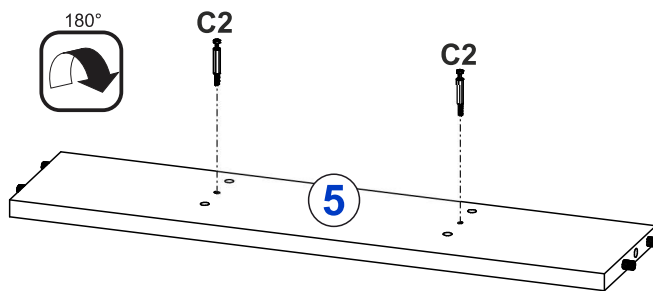
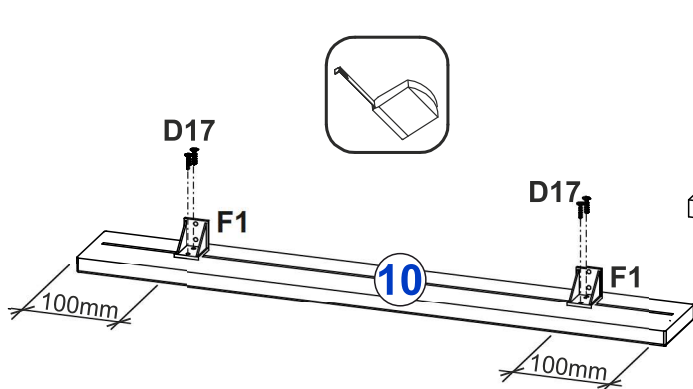
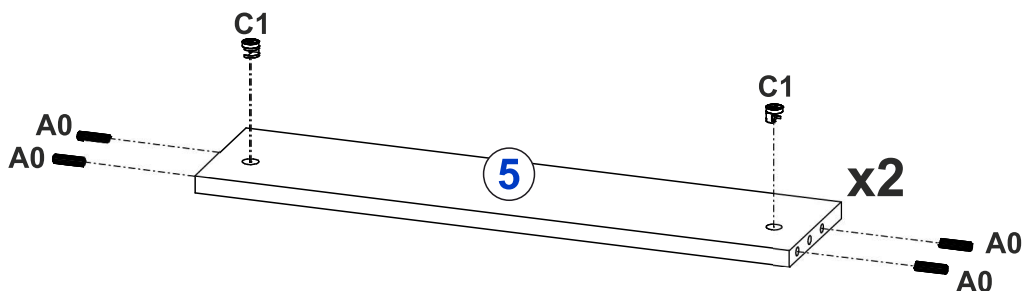
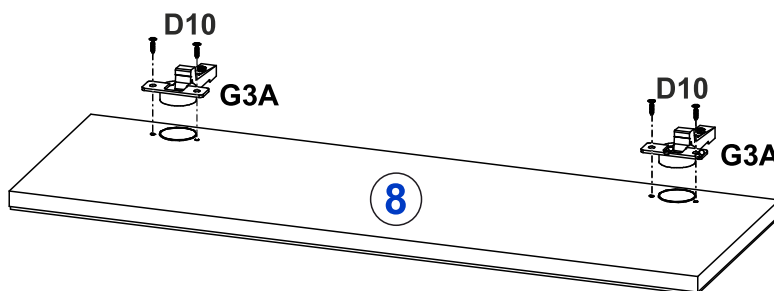
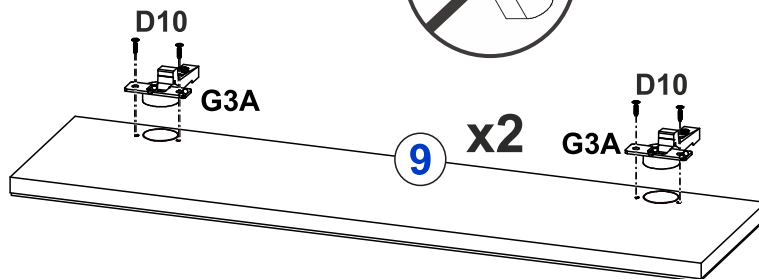
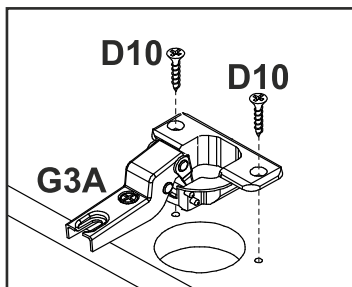
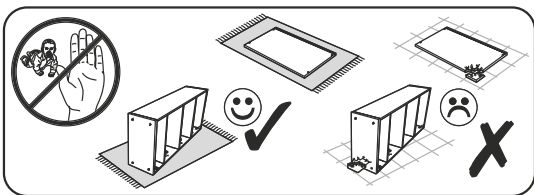

3

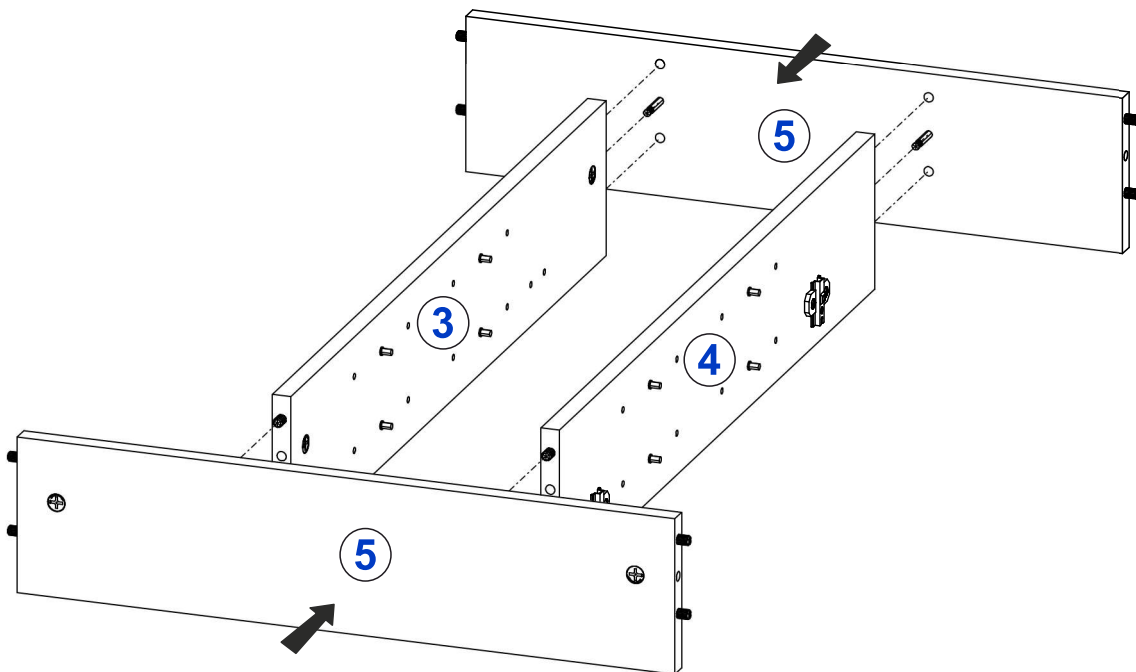
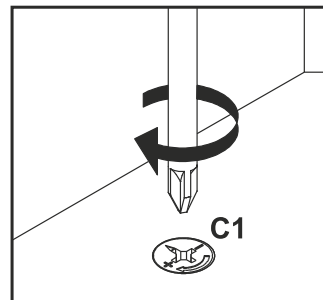
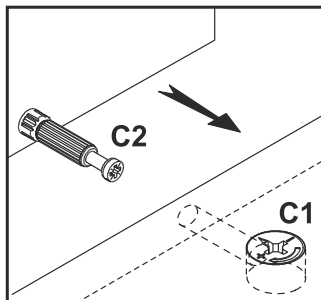

4

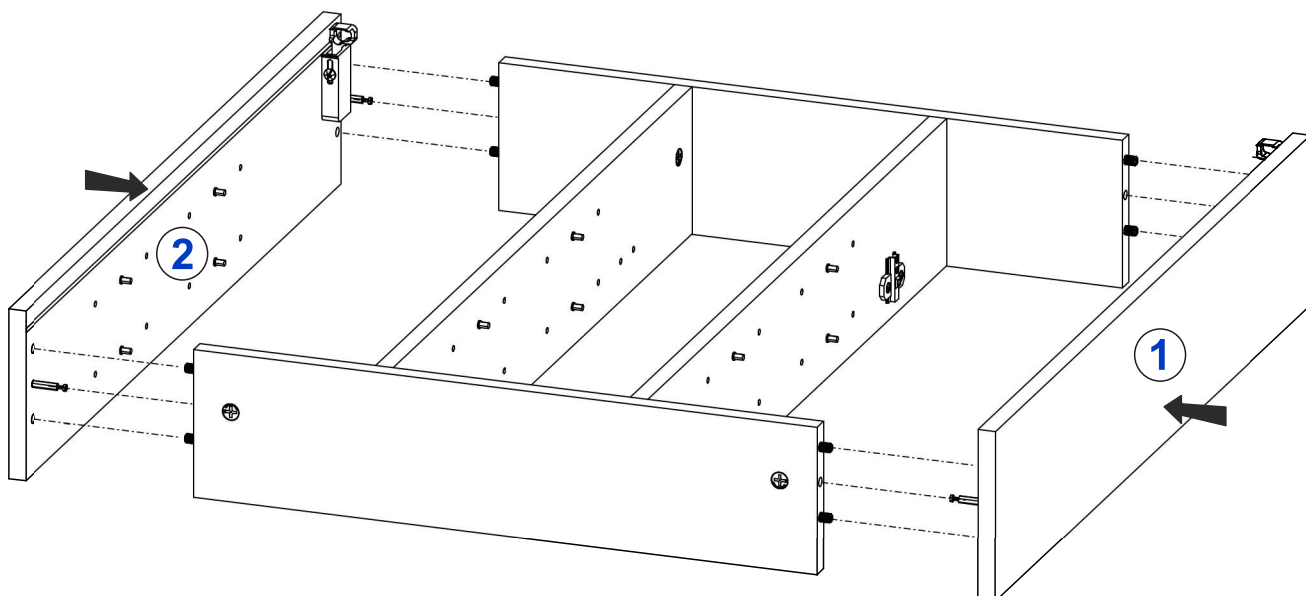
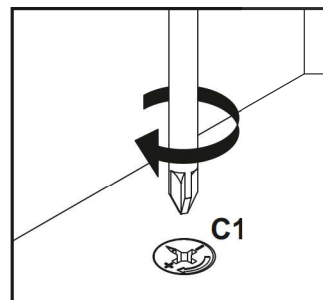
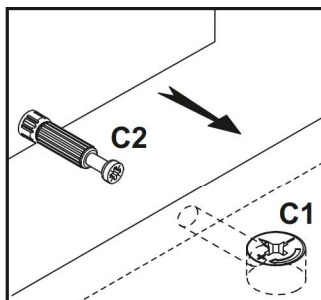

# 5

3,5x16



D17 x4

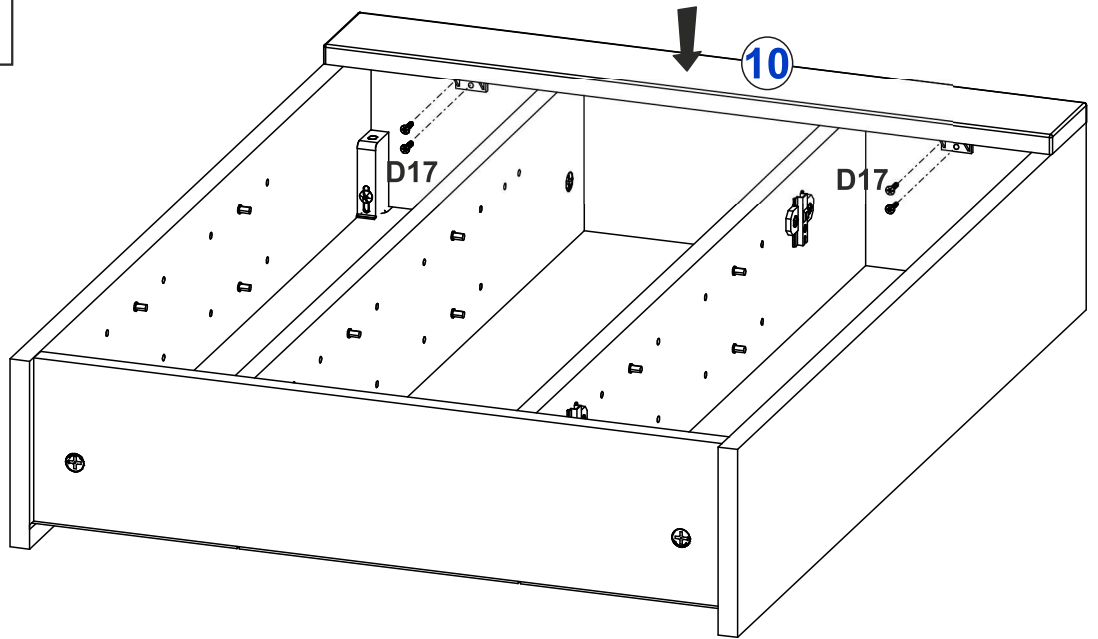
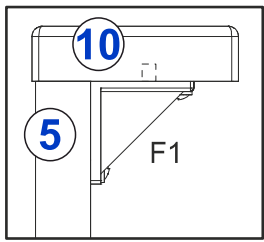

# 6

3x15



D0 x6

3,5x16



D17 x18



F0 x6



F10 x6

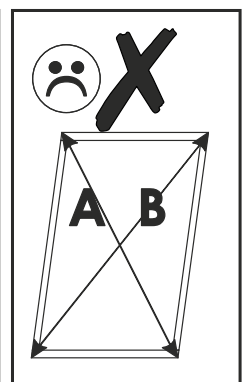
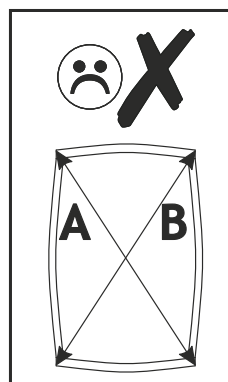
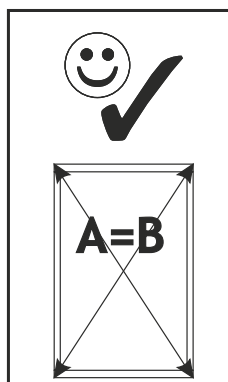
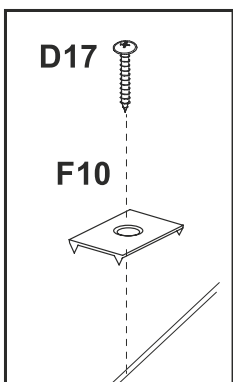
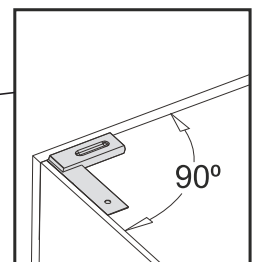
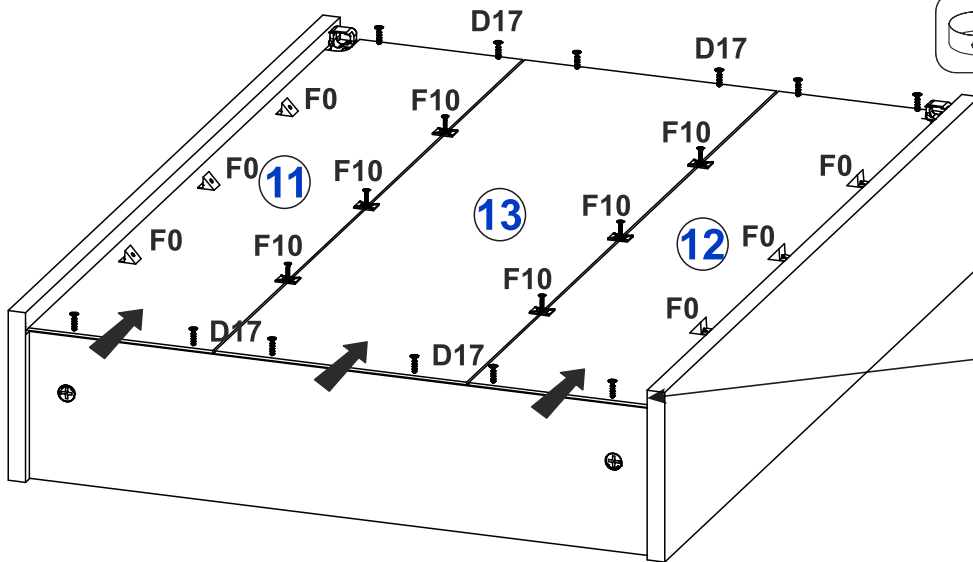
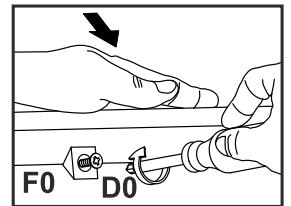
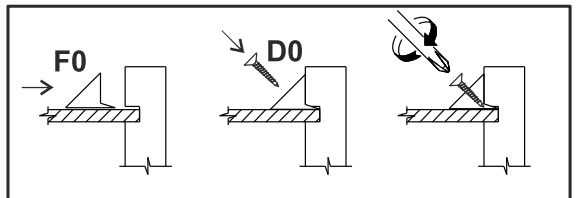

# 7

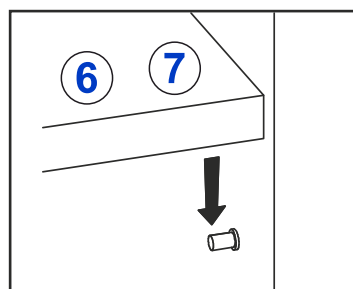
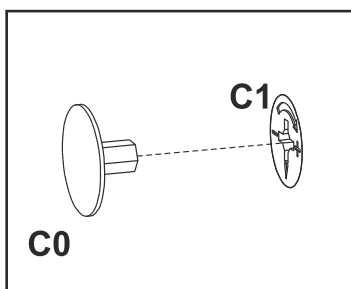
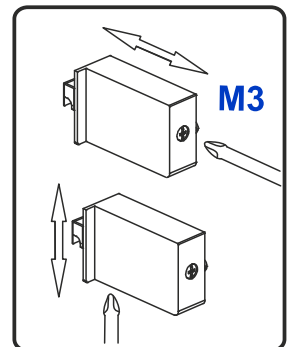
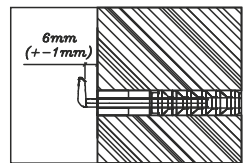
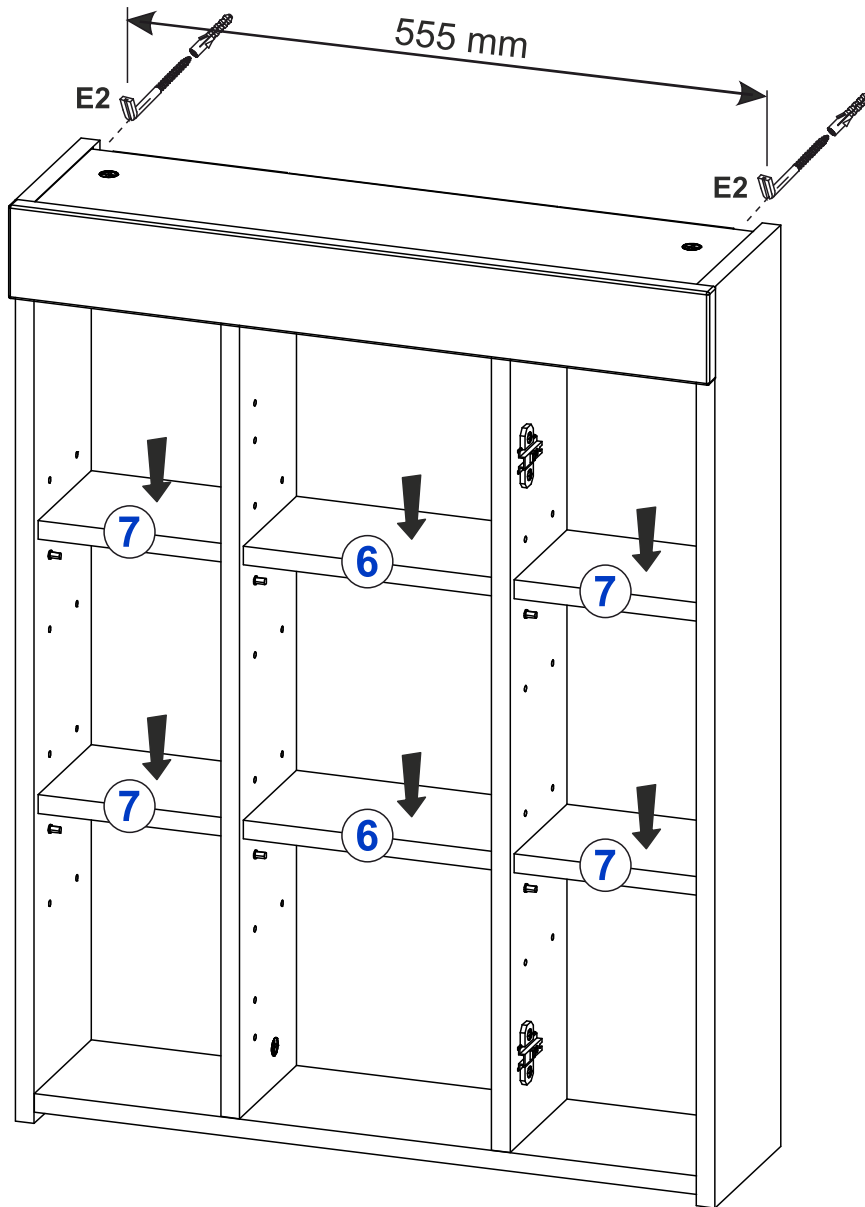
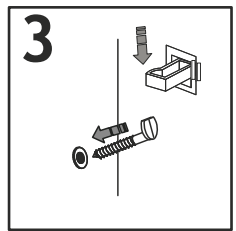
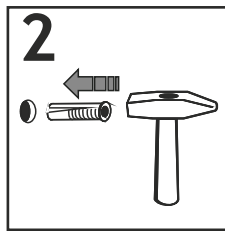
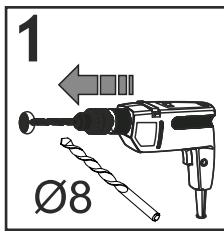
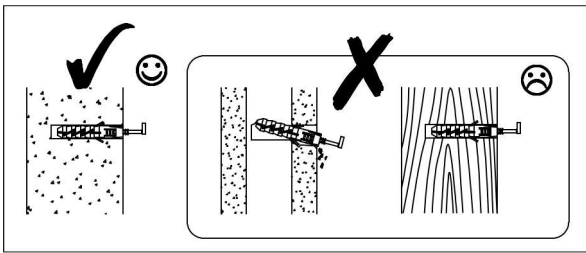
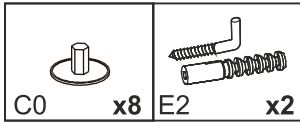

8

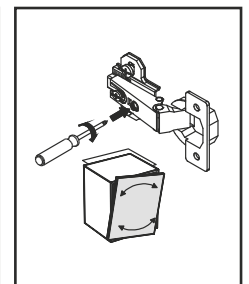
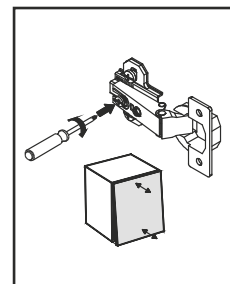
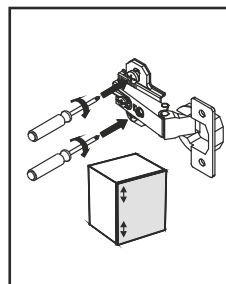
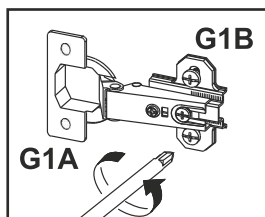
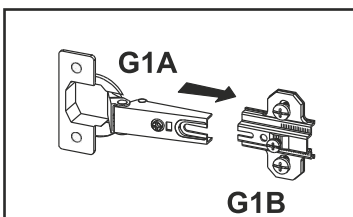
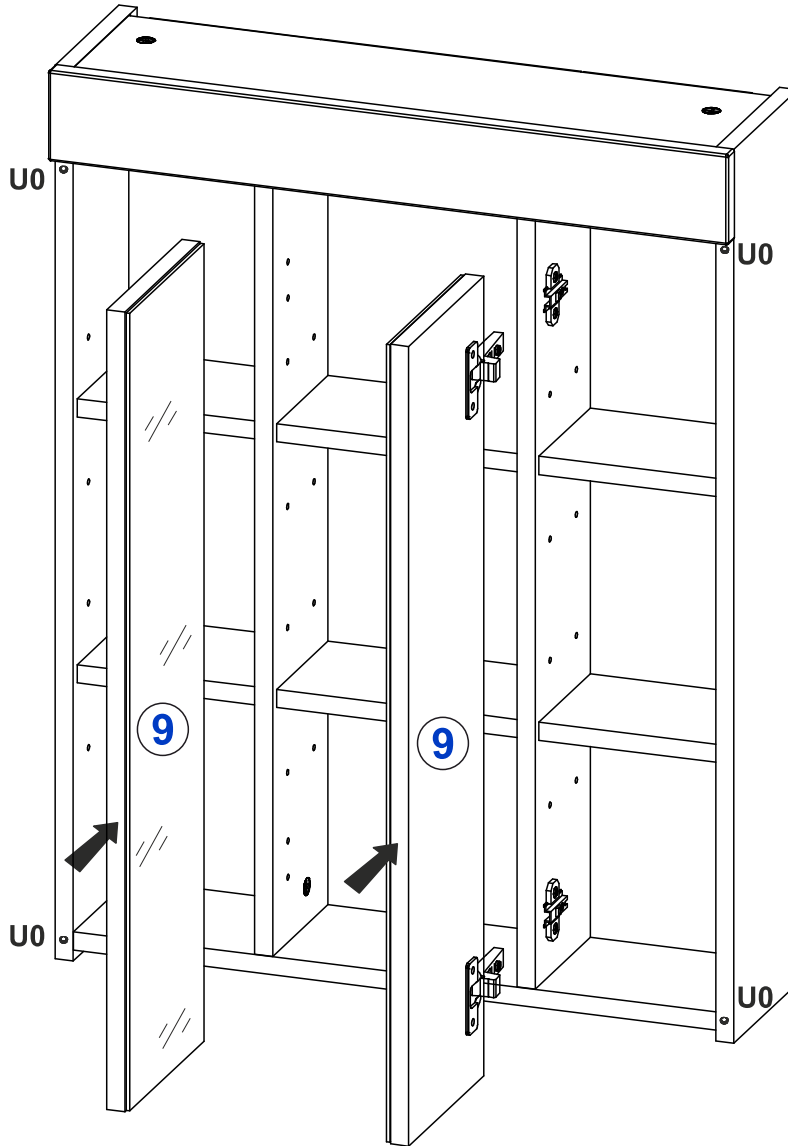
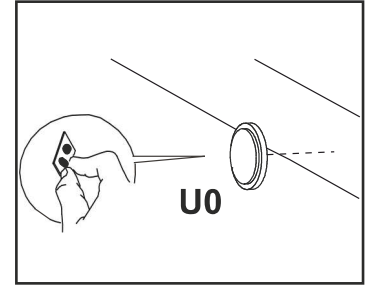
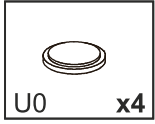

9

Ø5			
B54	x4	G1B	x2
		U0	x2

R L

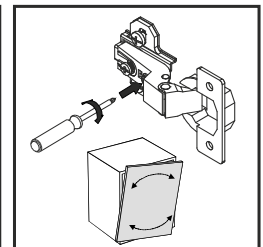
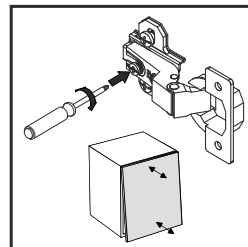
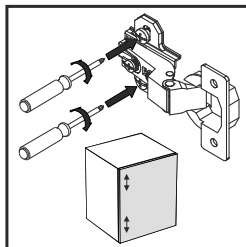
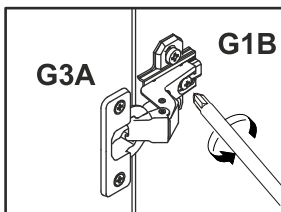
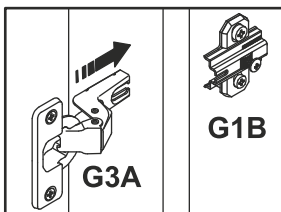
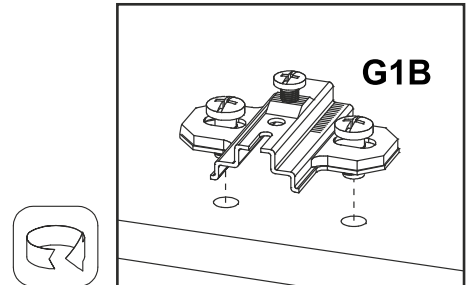
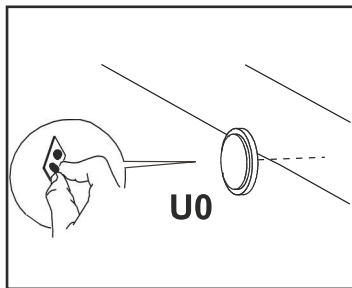
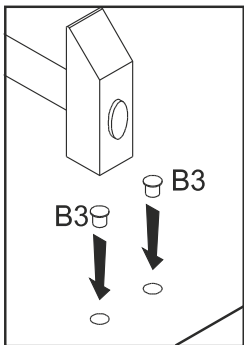
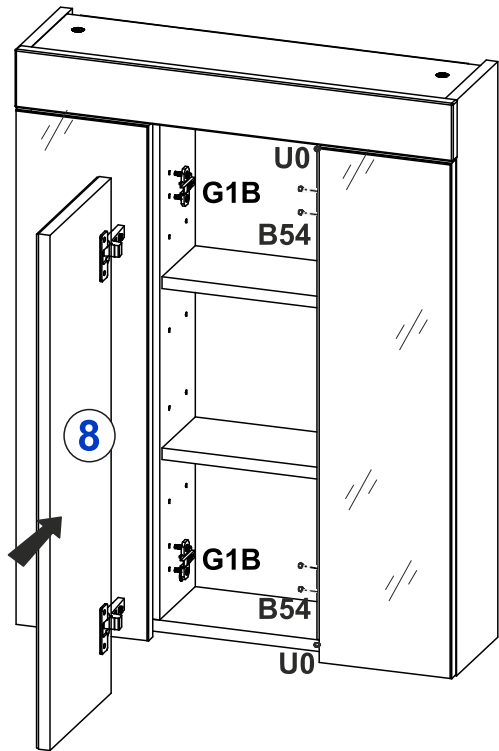
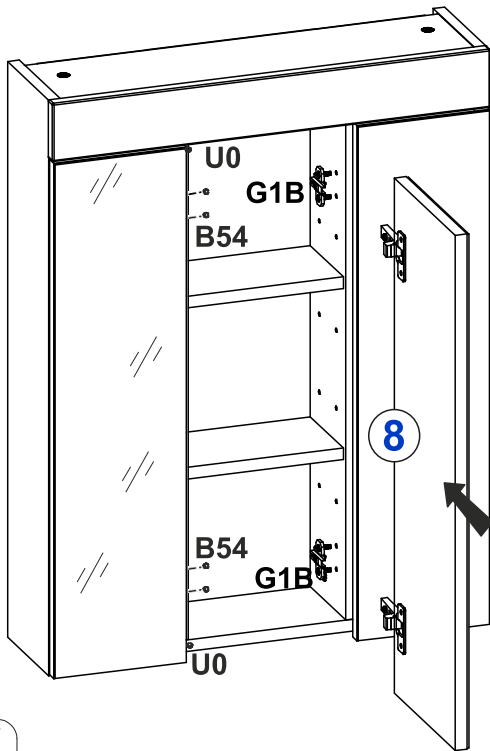
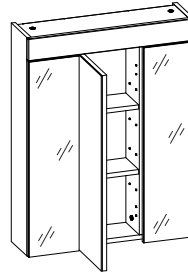
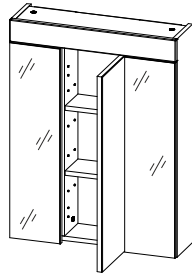

LKZ: X0105

Modellname / Model name / Nom du modèle / Modellnamn / Nome modello / Název modelu / Modelnaam / Ime modela / Numéro Modello / Modell neve / Название модели / Názov modelu / Ime modela / Denumire model / Наименование на модела / Nazwa modelu

# SNOW

Modellnummer / Number / Numéro du modèle / Numero / Номер на модела / modello / Číslo modelu / Modell száma / Éíslo modelu / Številka modela / Număr model / Broj modela / Modelnummer / Numer modelu

X19 A9 701

Type / Tipo / Típus / Typ / Тип / Tip

# 701

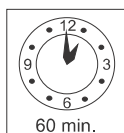
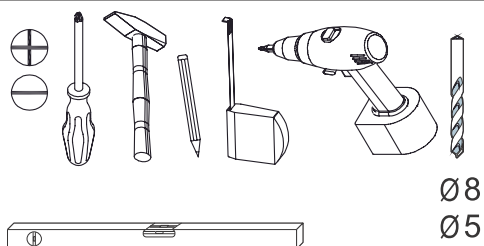
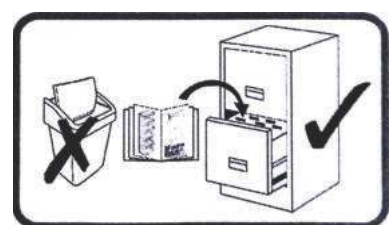
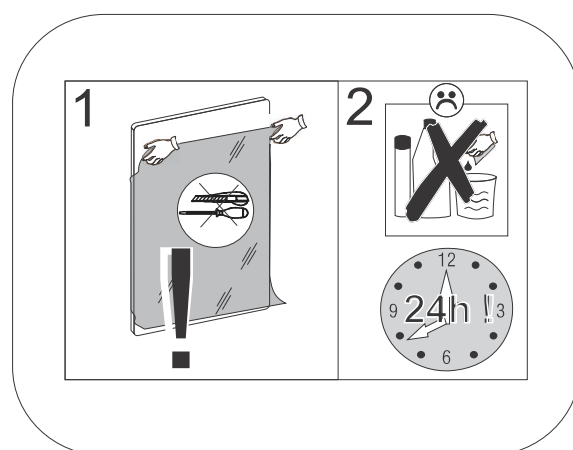
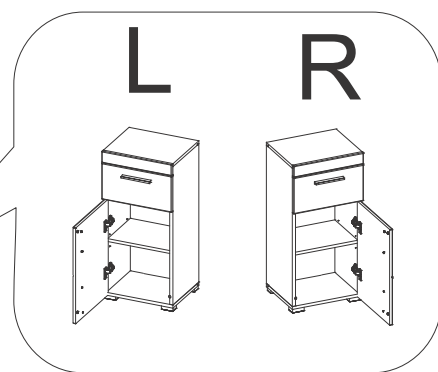
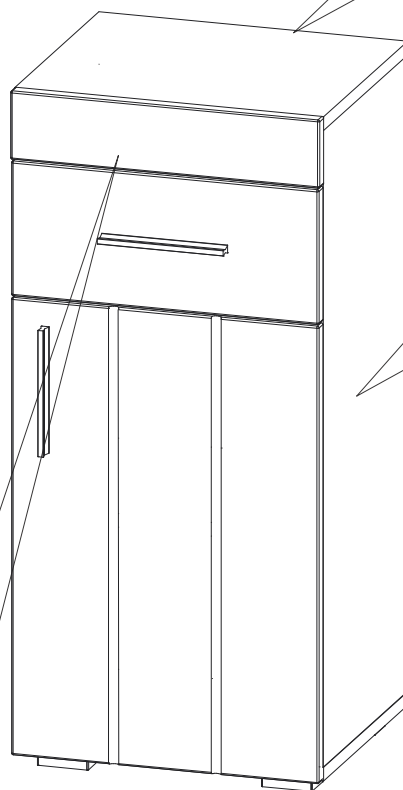
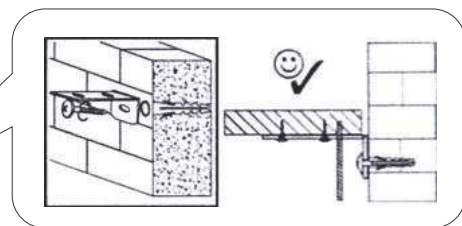
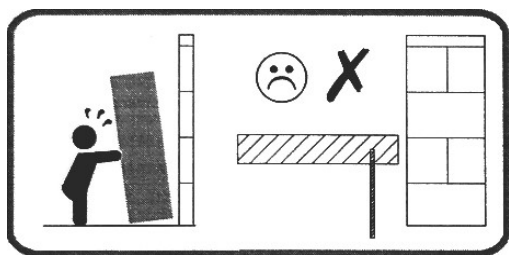
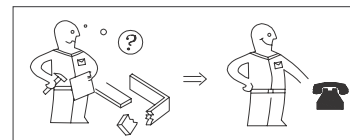
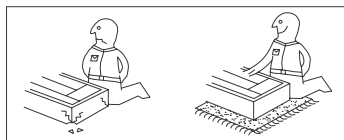
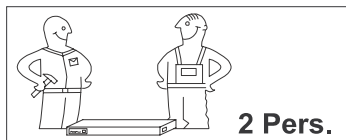
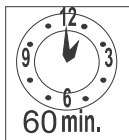

Ø8  
Ø5



festziehen / tighten / Затягивать / serrer / stringere / utáhnout / vasttrekken / zategnuti / strángere / zwiázac / zacisnac / szorosan meghúzni / pevne dotiahnut' / trdno pritegniti / затянуть / dra át



eindrücken / press in / enfoncer / wcisnac / ribattere / zatlačit / Вкарайте / indrukken / benyomni / stlačit' / vtsiniti / tryck in / introducere prin apă sare / вдвигать



ausmessen / measure / mesurer / misurare / opmeten / izmeriti / miara / kímérni / izmeriti / măsurare / измерить / zméřiti / Измерете / mät upp / zmierzyc



drücken / press / presser / stisknout / Натиснете / vtsiniti / nasinac / drukken / pritisnuti / nacisnac / pritisniti / нажать / (meg)nyomni / apă sare / tryck fast / nacisnac



einschlagen / hammer in / bevérni / sla in / frapper au marteau / infossare / Zabit' / zarazit / Набійте / zabiti / wbić / introduce prin bătaie / забить / zatloct



Drehen - wenden / przekręcić - odwrócić / Keren - omdraaien / Girare - Ruotare / Okrenuti - ubrnuti / Retourner - renverser / Turn over - turn around / Otocte - obratit' / Zавъртете - обвъртете / Obrnite list / Întoarceți - rotiți / Vrid runt - vänd / прокрутить - повернуть / otočit - obrátit / elforgatni - megfordítani



LKZ: XO105

Modellname / Model name / Nom du modèle / Modellnamn  
Nome modello / Název modelu / Modelnaam / Ime modela  
Número Modelo / Modell neve / Название модели /  
Názov modelu / Ime modela / Denumire model /  
Наименование на модела / Nazwa modelu

**SNOW**

Modellnummer / Number / Numéro du modèle  
Numero / Номер на модела / modello  
Číslo modelu / Modell száma / Ěíslo modelu  
Številka modela / Număr model / Broj modela  
Modelnummer / Numer modelu

**X19 A9 701**

Type / Tipo / Típus / Typ / Тип / Tip

**701**

**D** **Unser Direktservice für Beschlagteile**  
Sollte Ihnen ein Beschlagteil fehlen, können Sie diese Servicekarte direkt an die untenstehende Adresse mailen. Wir können allerdings nur Beschlagteile auf diesem Wege verschicken. Sollten Sie eine andere Beanstandung an Ihrem Möbelstück haben, so wenden Sie sich bitte direkt an Ihr Möbelhaus.

**GB** **Our direct order service for fitting**  
If a fitting part is missing, you can e-mail this service card directly to the address below. However, we can only send fitting parts in this way. If you have any other cause for complaint concerning your item of furniture, please contact your furniture store directly.

**CZ** **Naše přímé služby pro kování**  
Chybí-li vám nějaký díl z kování, můžete tuto servisní kartu odeslat e-mailem přímo na níže uvedenou adresu. Touto cestou však můžeme zoslat jen díly kování. Pokud byste reklamovali jiný díl nábytku, obraťte se přímo na svého prodejce nábytku.

**F** **Bien étudier la notice de montage**  
S'il vous manque une ferrure, veuillez envoyer directement la présente carte service à l'adresse e-mail indiquée ci-dessous. Cependant, ceci nous permet uniquement d'envoyer des ferrures. Pour tout autre type de réclamation concernant votre meuble, veuillez contacter directement votre magasin d'ameublement.

**I** **Il nostro servizio diretto per l'ordine della ferramenta**  
Qualora Vi dovesse mancare un pezzo di fissaggio, allora Vi preghiamo di inviare questa carta di servizio immediatamente all'indirizzo sottostante. Possiamo inviare i pezzi di fissaggio solamente per mezzo di questo procedimento. Qualora doveste avere qualche altra reclamazione in merito al mobile, allora Vi preghiamo di rivolgerVi direttamente al Vostro Negozio di mobili.

**BG** **Нашата директна услуга за обков**  
Ако липсват части от комплекта, потърнете настоящата сервисна карта и ни я изпратете на e-mail адреса, посочен по-долу. По този начин можем да доставяме само липсващи елементи от обкова. Ако установите други дефекти по мебелите, Ви съветваме да се обърнете към мебелната къща/магазин, от който сте закупили стоката.

**NL** **Onze directservice voor losse onderdelen**  
Wanneer er een onderdeel ontbreekt, kunt u deze servicekaart direct aan onderstaand e-mailadres sturen. Wij kunnen langs deze weg echter alleen beslagdelen versturen. Mocht u een ander probleem aan uw meubel hebben, verzoeken wij u contact op te nemen met uw meubeldealer.

**PL** **Nasz bezpośredni serwis części montażowych**  
Jeżeli brakuje części koniecznych do montażu, prosimy o przesłanie nam niniejszej karty serwisowej na niżej podany adres e-mailowy. W ten sposób możemy przysłać Państwu tylko brakujące części. W przypadku innych reklamacji dotyczących mebla, prosimy zgłosić się do salonu meblowego, w którym został dokonany zakup.

**HR** **Servis za okove**  
U slučaju da nedostaje neki od dijelova molimo vas da na dole navedenu mail adresu pošaljete ovaj servisni obrazac. Na ovaj način mogu se dostaviti samo okovi. U slučaju da imate dodatne prigovore vezane uz komad namještaja molimo vas da se obratite izravno trgovini namještaja gdje je isti kupljen.

**HU** **Direktszolgáltatunk vasalatok eseten**  
Ha hiányzik egy vasalat, ezt a kártyát közvetlenül elküldheti az alábbi társalati címre. Azonban csak vasalatoskat tudunk így küldeni. Amennyiben másfajta reklamációt áll fenn bútordarabát illetően, forduljon közvetlenül a bútortárhoz.

**SK** **Náš priamy servis pre časti kovania**  
Ak by Vám chýbala nejaká časť kovania, môžete poslať túto servisnú kartu pošlat e-mailom na nižšie uvedenu adresu. Díly kovania vieme poslať iba týmto spôsobom. Ak by ste mali inú reklamáciu ošhadom Vašho nábytku, obraťte sa priamo na Vašu predajňu nábytku.

**SLO** **Naše direktno uslužne storitve za okovje**  
Če vam manjka kakšno okovje, lahko to servisno kartico pošljete po e-pošti direktno na spodnji naslov. Po tej poti vam lahko pošljemo samo okovje. Če želite reklamirati kakšen drug del pohištva, se obrnite neposredno na vašo trgovino pohištva.

**RO** **Service-ul nostru direct pentru feronerie**  
În cazul în care vă lipsește o piesă de feronerie puteți să trimiteți direct acest card de service prin e-mail la adresa de mai jos. Noi nu putem expedia piese de feronerie decât pe această cale. Dacă aveți o altă reclamație referitoare la piesa de mobilier, atunci vă rugăm să vă adresați direct la magazinul dvs. de mobilă.

**RUS** **Наш прямой сервис для поставок фурнитуры**  
Если окажется, что Вам не хватает того или иного элемента фурнитуры, Вы можете отправить сервисную карту по факсу непосредственно на нижеприведенный адрес электронной почты. Однако, таким образом мы можем пересылать лишь фурнитуру. Если же у Вас возникнут иные претензии относительно приобретенной мебели, пожалуйста, обращайтесь непосредственно в организацию, осуществившую продажу.

**S** **Vår directservice för beslagsdelar**  
Om du saknar en beslagsdel kan du skicka detta servicekort direkt till e-postadressen som anges nedan. Tänk på att detta är den enda möjligheten att skicka beslagsdelar till dig. Om du vill reklamera din möbel av en annan anledning måste du kontakta ditt möbelhus direkt.

**ES** **Nuestro servicio directo para accesorios**  
Si le falta algún accesorio, puede enviar esta tarjeta de servicio directamente a la siguiente dirección. No obstante, por este método solo podemos enviar accesorios. Si tiene alguna otra objeción sobre su mueble, consulte directamente con su mueblería.

**TR** **Donatılar için doğrudan servisimiz**  
Bir donatınız eksikse bu servis kartını doğrudan aşağıda bulunan adrese doğrudan mail yazabilirsiniz. Sadece bu yolla donatılar gönderilebilir. Mobilyanızda başka şikayetleriniz varsa lütfen doğrudan mobilya satıcınıza danışın.

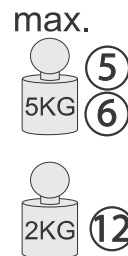
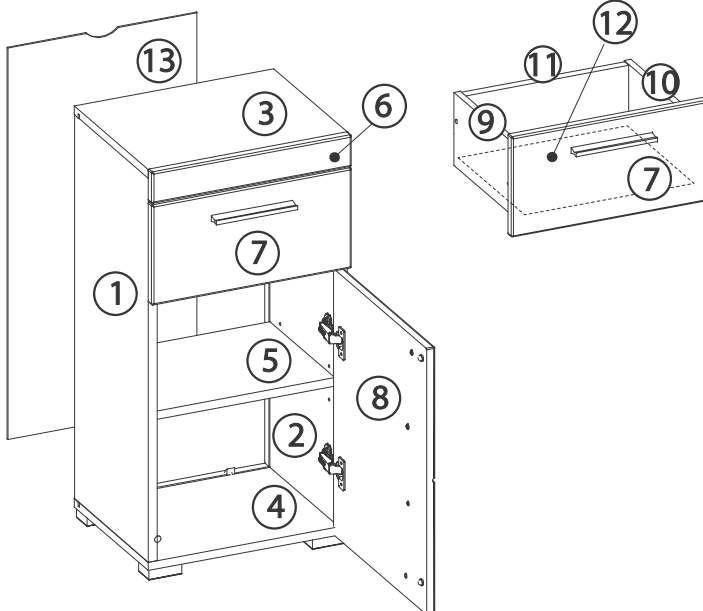

Nr.	Maße mm			Colli	Anzahl
1	746	305	16	1/1	1
2	746	305	16	1/1	1
3	364	305,5	16	1/1	1
4	364	305,5	16	1/1	1
5	331	275	16	1/1	1
6	80	364	16	1/1	1
7	158	362	16	1/1	1
8	536	362	16	1/1	1
9	250	120	16	1/1	1
10	250	120	16	1/1	1
11	273	116	16	1/1	1
12	283	244	2,5	1/1	1
13	756	341	2,5	1/1	1
B1				1/1	1

Grund der Beanstandung / Reason of the objection:

Möbelhaus / Furniture store:

Name / Name: Telefon / Telephone:

PLZ / postal code: Ort / City:

Strasse / Street:

Haus-Nr. / House No.:

@E-Mail:

E-Mail Kundenservice / Customer service e-mail / E-mail servisního střediska / E-mail de notre service clientèle / e-mail servizio clienti / E-mail на отдела за обслужване на клиенти / E-mail klantenservice / E-mail servisu dla klientów / Servisna mail adresa / Az ügyfélszolgálat e-mail címe / E-mail zákaznického servisu / E-pošta Servisna služba / E-mail Serviciu clienți / E-Mail сервисной службы / E-postadress kundservice / Servicio de atención por correo electrónico / Müşteri hizmetleri e-postası

service@xonox-home.com  
Hotline xonox.home GmBH  
0049-(0)5261-92020800

LKZ: XO105

Modellname / Model name / Nom du modèle / Modellnamn  
Nome modello / Název modelu / Modelnaam / Ime modela  
Número Modelo / Modell neve / Название модели /  
Názov modelu / Ime modela / Denumire model /  
Наименование на модела / Nazwa modelu











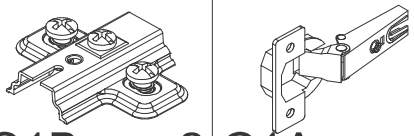
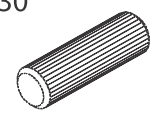

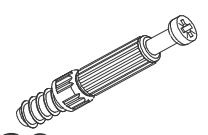

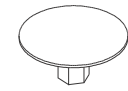
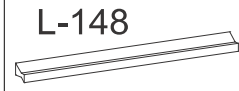

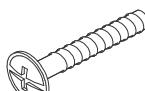
**SNOW**

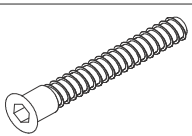
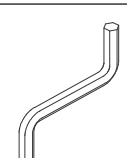
Modellnummer / Number / Numéro du modèle  
Numero / Номер на модела / modello  
Číslo modelu / Modell száma / Ěíslo modelu  
Številka modela / Număr model / Broj modela  
Modelnummer / Numer modelu

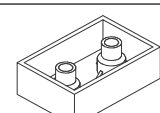
**X19 A9 701**

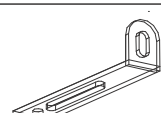
Type / Tipo / Típus / Тип / Тип / Tip

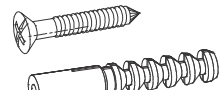
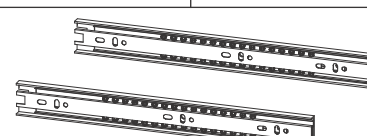
**701**

 <p><b>G1B</b> x2 <b>G1A</b> x2</p>		<b>B1</b>			
 <p><b>A0</b> x10</p>	 <p><b>H0</b> x4</p>	 <p><b>C1</b> x6</p>	 <p><b>C2</b> x6</p>	 <p><b>B0</b> x8</p>	 <p><b>D10</b> x4</p>
 <p><b>C0</b> x6</p>	 <p><b>L30</b> x2</p>	 <p><b>D20</b> x10</p>	 <p><b>D18</b> x4</p>	 <p><b>D14</b> x8</p>	 <p><b>D0</b> x16</p>
 <p><b>B1</b> x8</p>	 <p><b>Z</b> x1</p>	 <p><b>D17</b> x10</p>	 <p><b>T1</b> x4</p>	 <p><b>B3</b> x6</p>	 <p><b>I1</b> x1</p>
 <p><b>F0</b> x12</p>	 <p><b>U0</b> x4</p>	 <p><b>E0</b> x1</p>	 <p><b>N21</b> x1</p>	 <p><b>F1</b> x2</p>	

1

A1 x8	D20 x6	H0 x4	C1 x4	C2 x4
4x20	5x13	T1 x4	N21 x2	
D14 x8	3,5x16			
F1 x2				

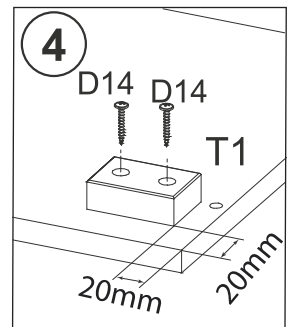
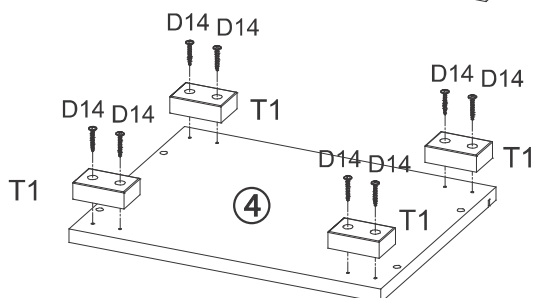
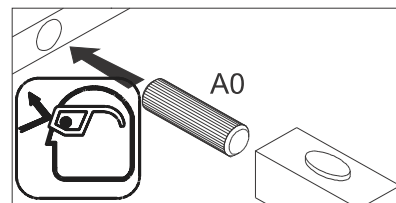
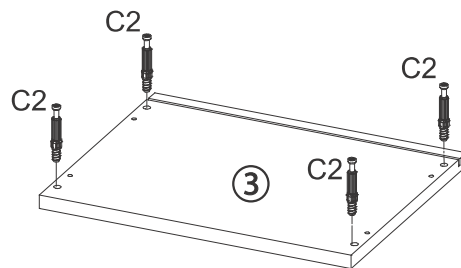
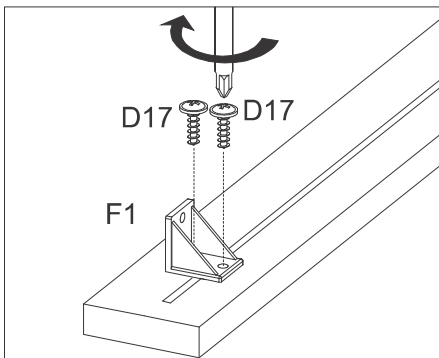
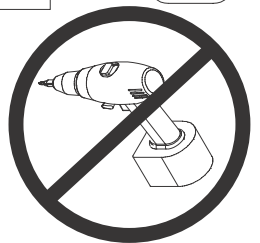
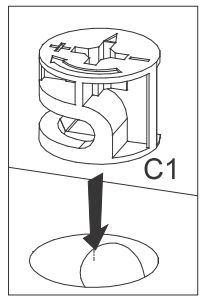
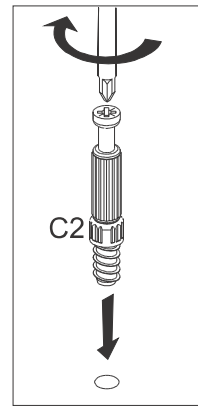
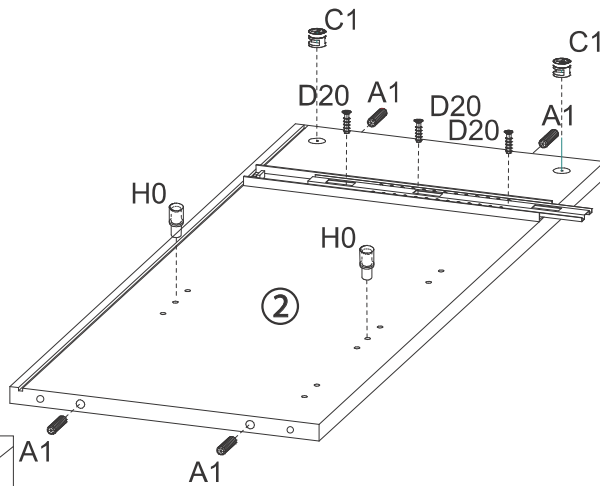
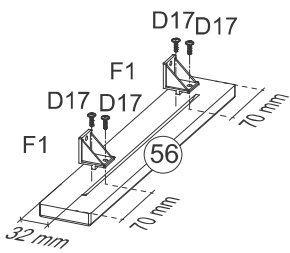
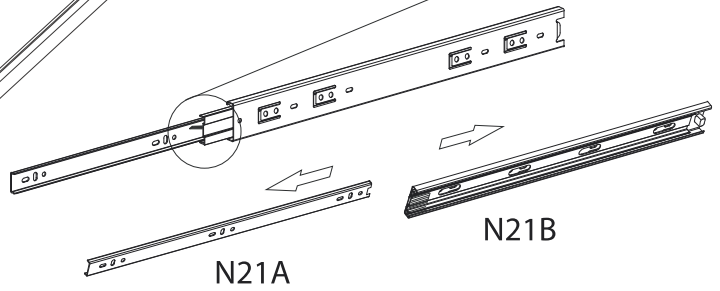
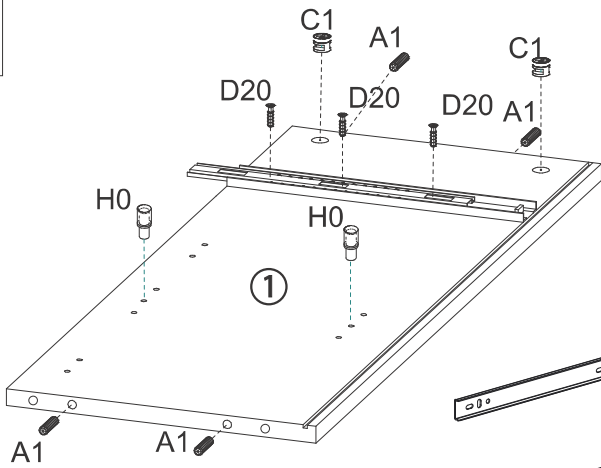
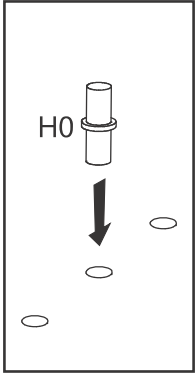
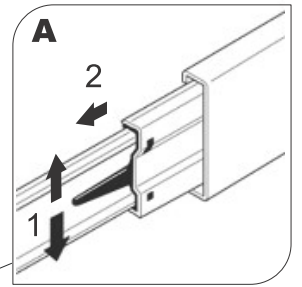
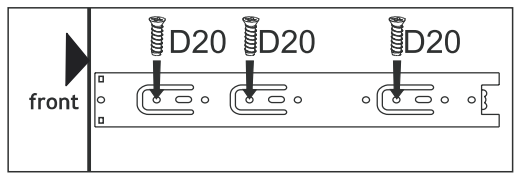

2

- |            |    |    |    |    |    |              |    |             |    |             |    |             |    |     |    |
|------------|----|----|----|----|----|--------------|----|-------------|----|-------------|----|-------------|----|-----|----|
| 8x35<br>A0 | x2 | C1 | x2 | C2 | x2 | L-148<br>L30 | x1 | 4x25<br>D18 | x2 | 1,5mm<br>U0 | x2 | 5x13<br>D20 | x4 | N21 | x2 |
|------------|----|----|----|----|----|--------------|----|-------------|----|-------------|----|-------------|----|-----|----|

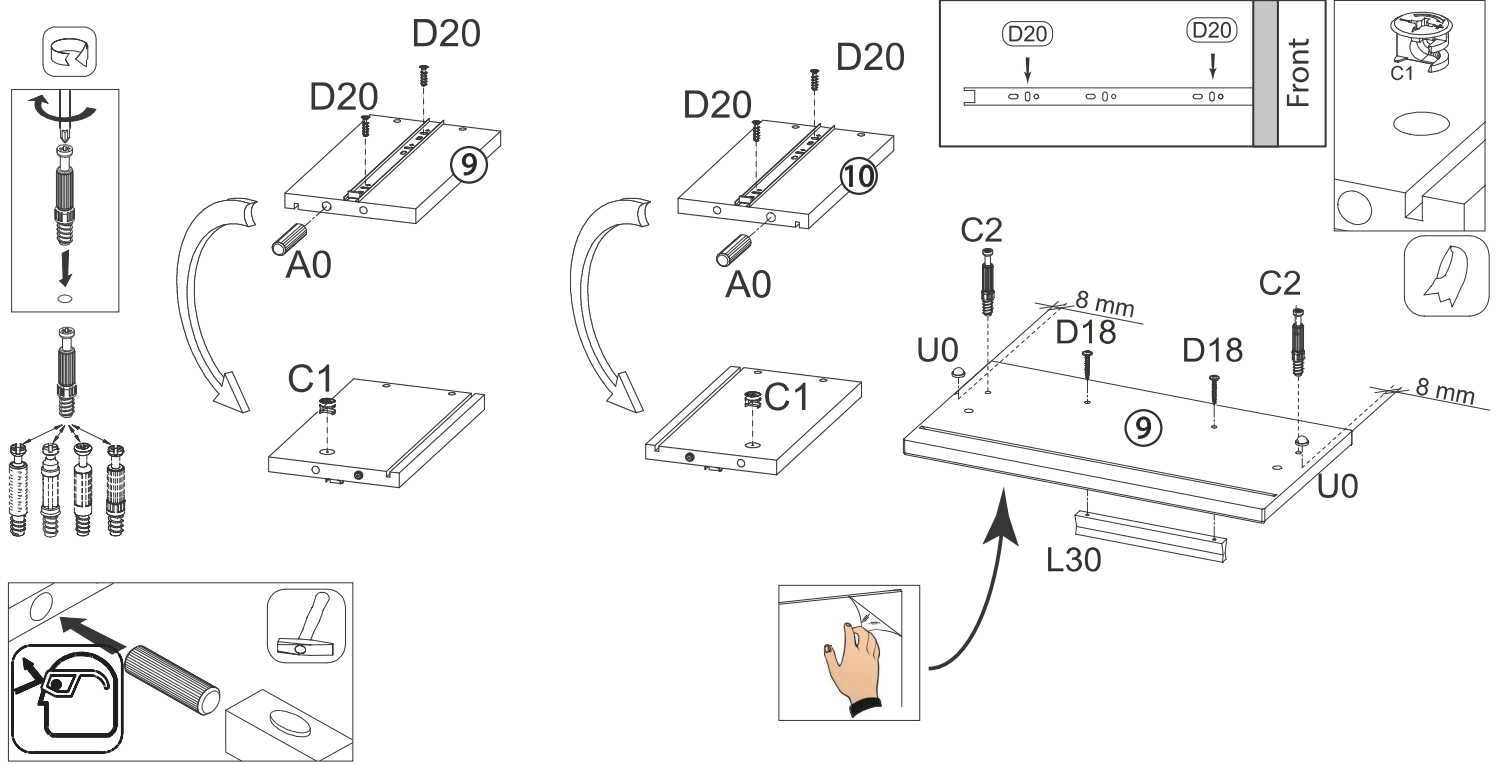

3

- |    |    |    |    |   |    |
|----|----|----|----|---|----|
| B0 | x4 | B1 | x4 | Z | x1 |
|----|----|----|----|---|----|

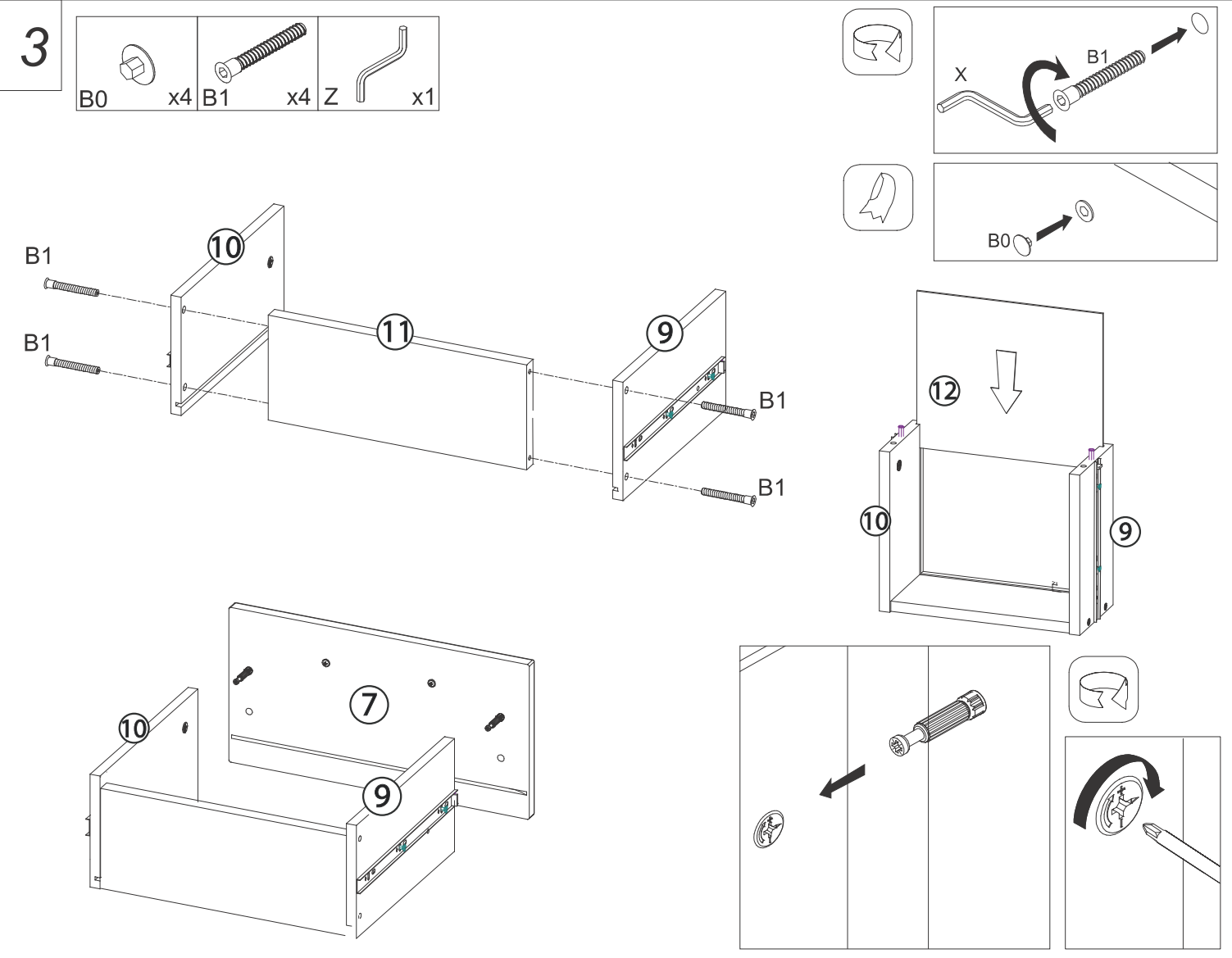

4

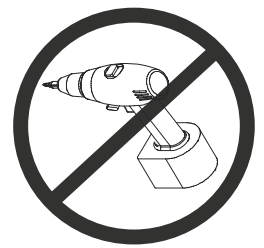
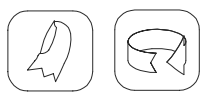
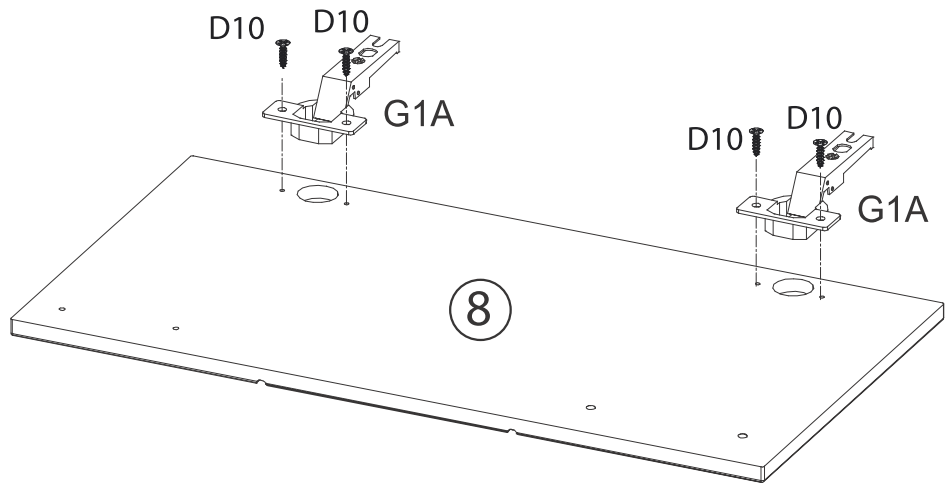
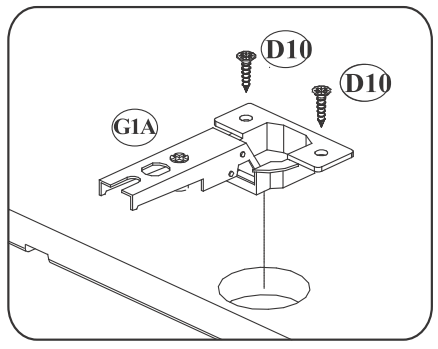
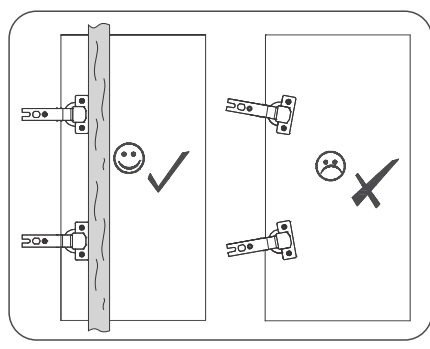
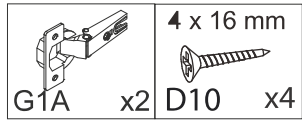

5

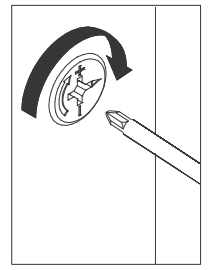
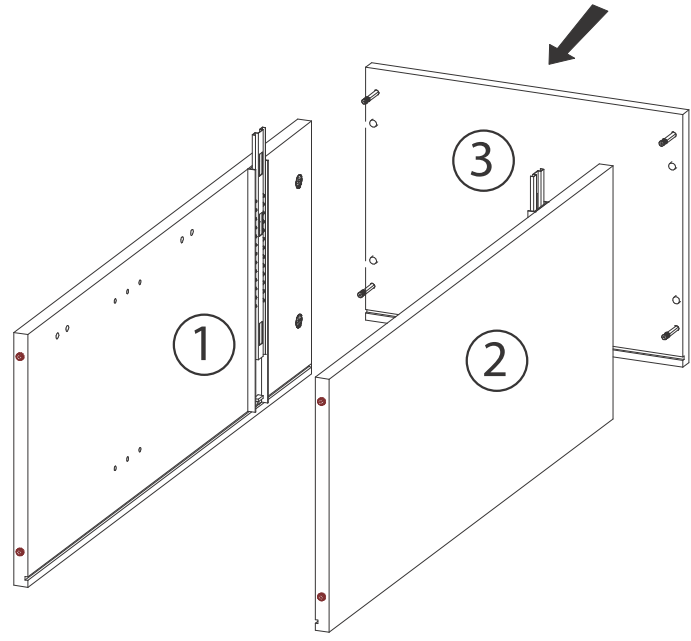
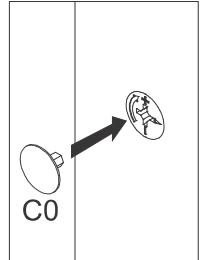
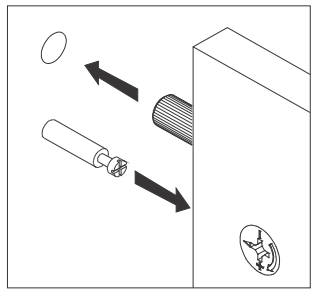
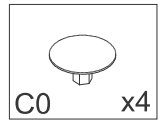

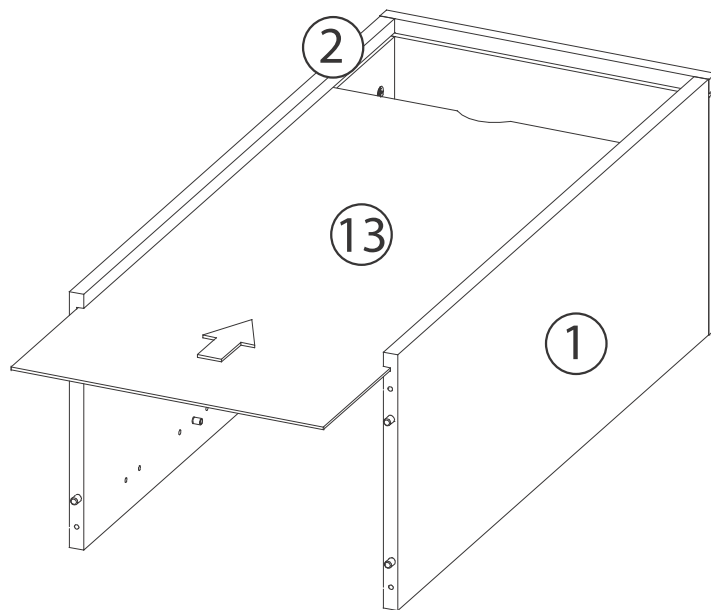

6

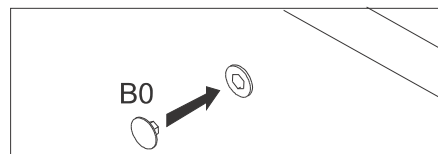
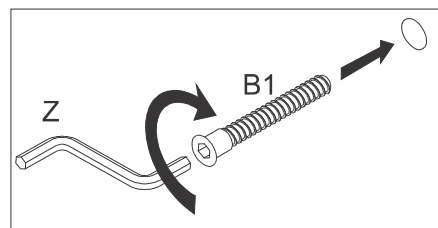
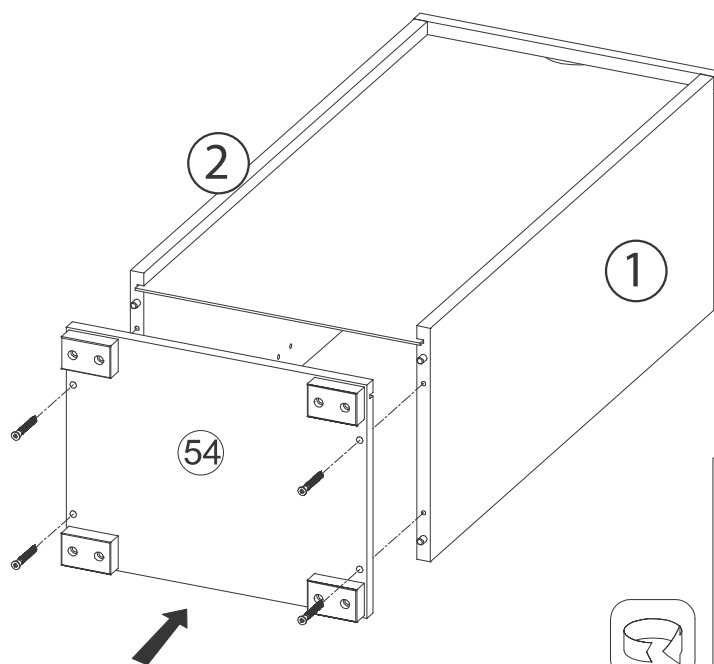
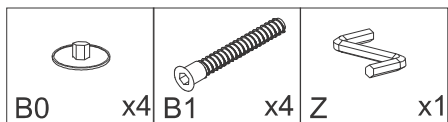

7



8

	3 x 15 mm
F0 x12	 x12

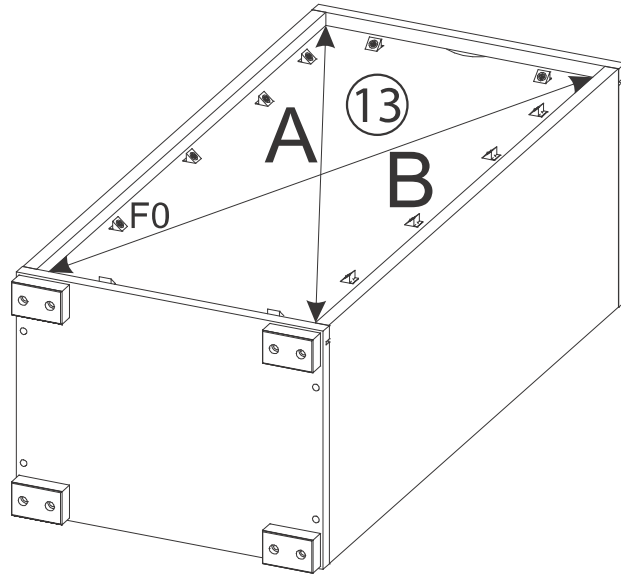

A=B

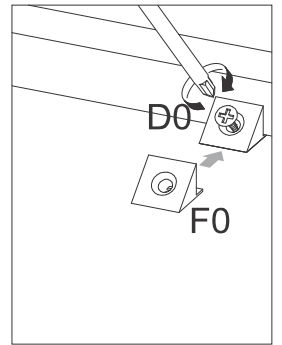

9

	3,5 x 16 mm
D17 x4	

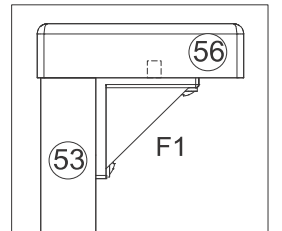
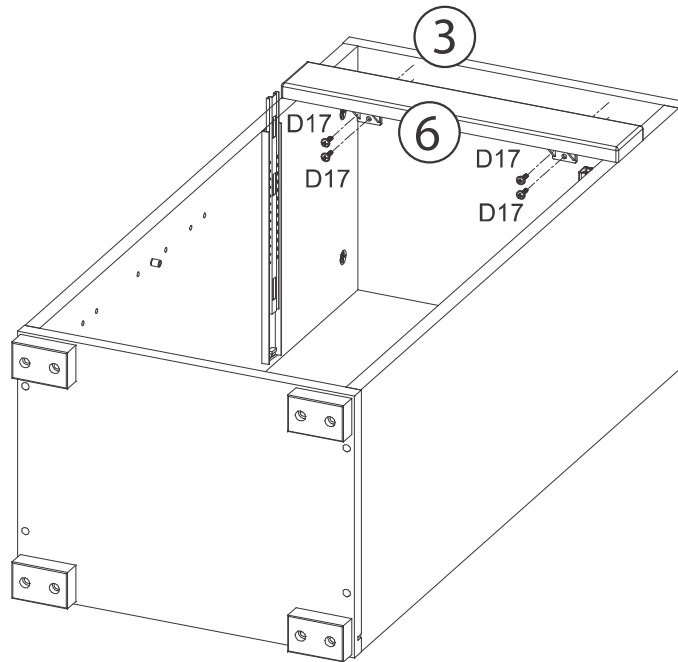

10

3,5 x 16 mm



D17 x2

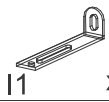

I1 x1

6 x 60 mm  
10 x 50 mm



E0 x1

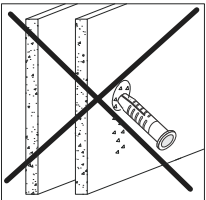
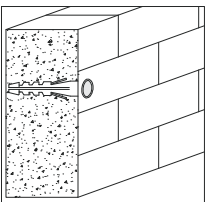
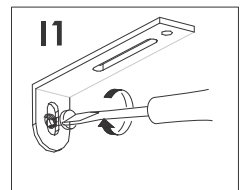
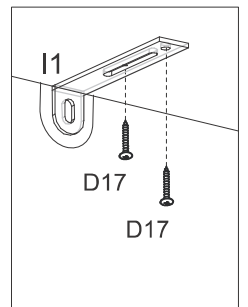
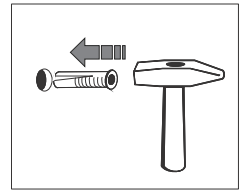
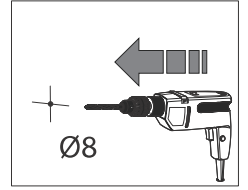
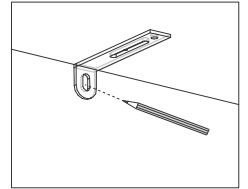
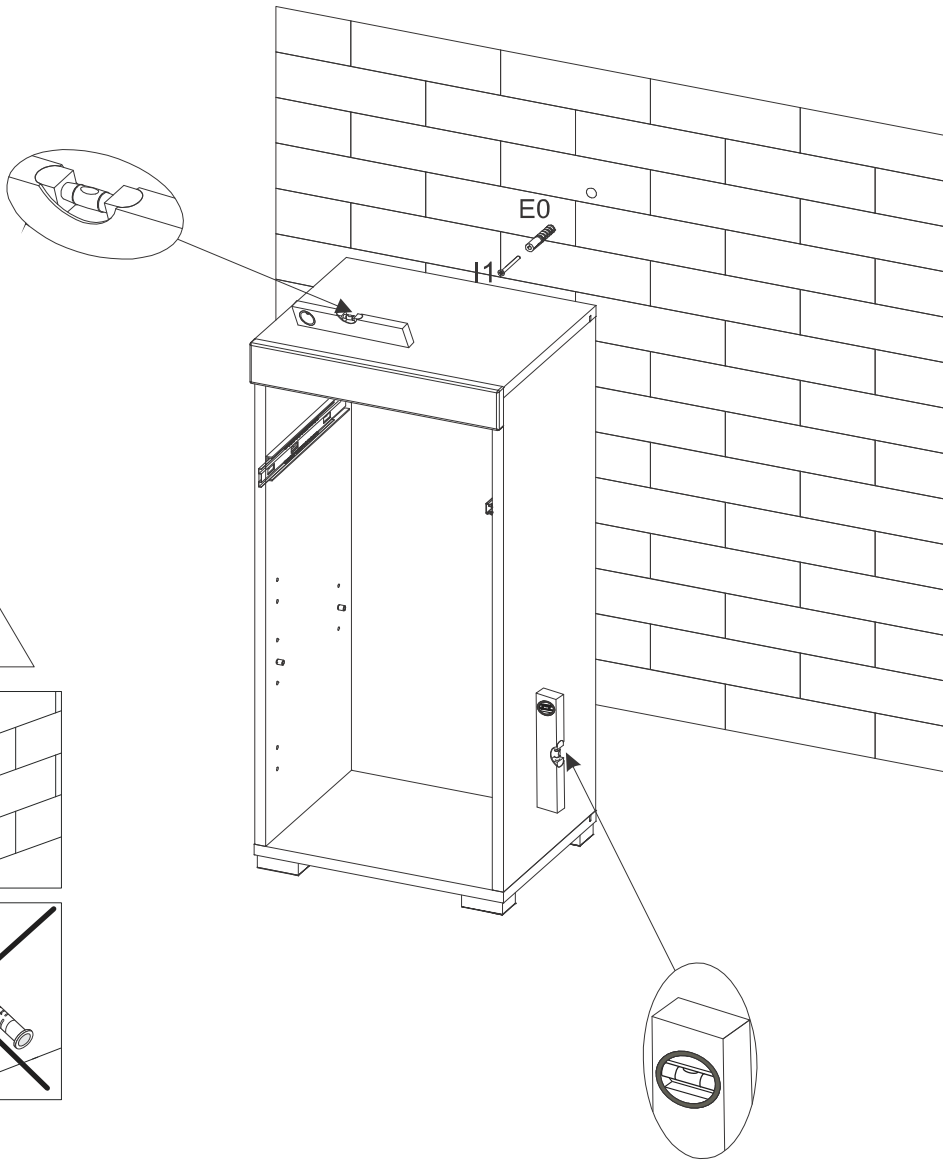



11

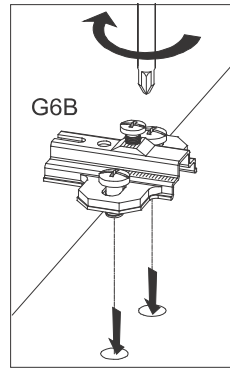
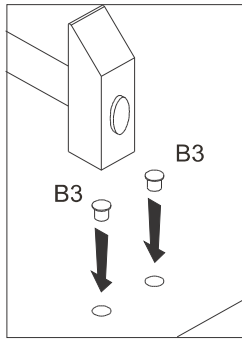
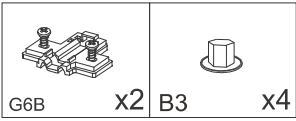

L



R

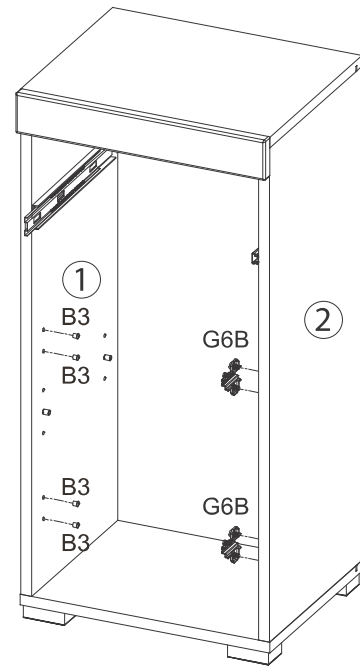
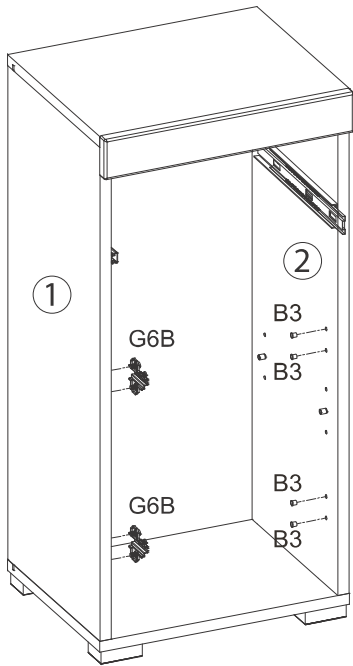
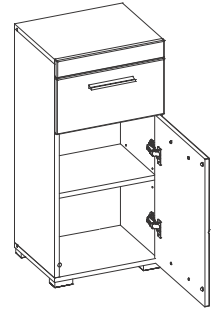
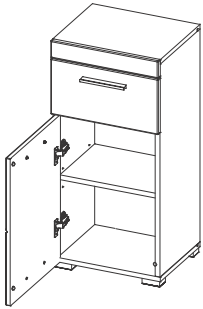

12

3 x 15 mm



D0 x4

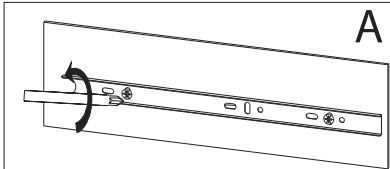

A

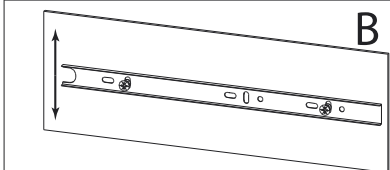

B

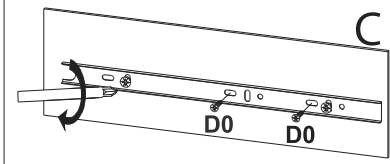

C

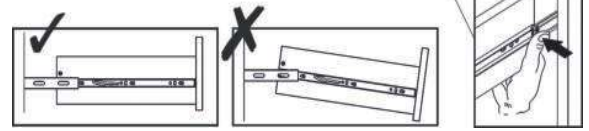
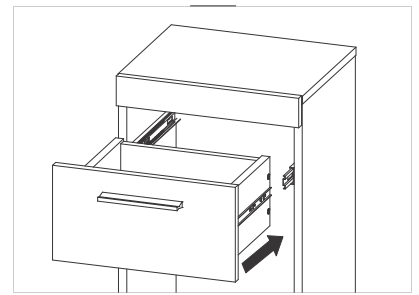
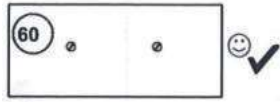
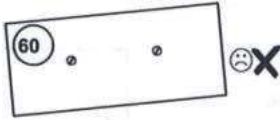

L

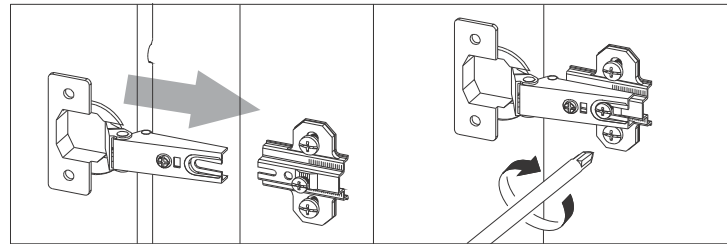
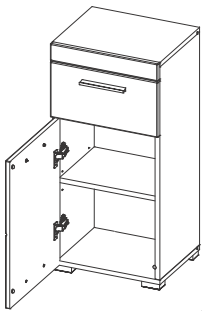

R

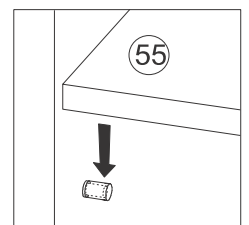
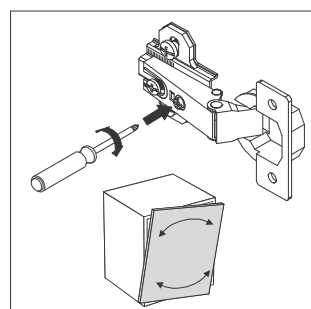
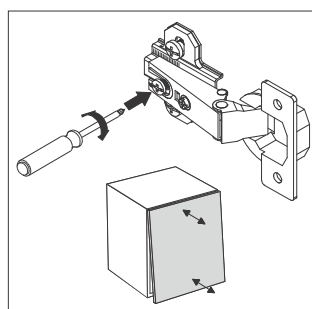
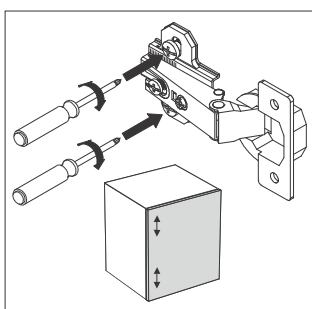
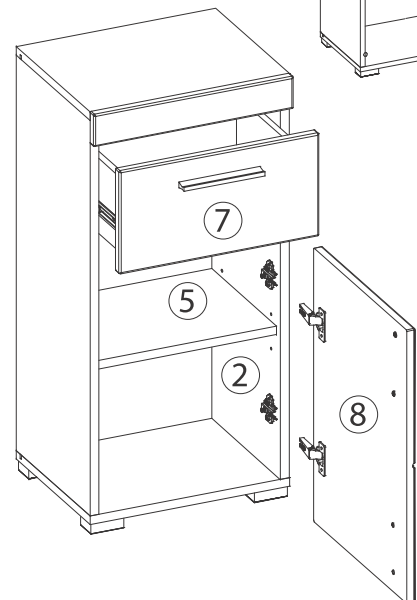
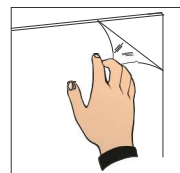
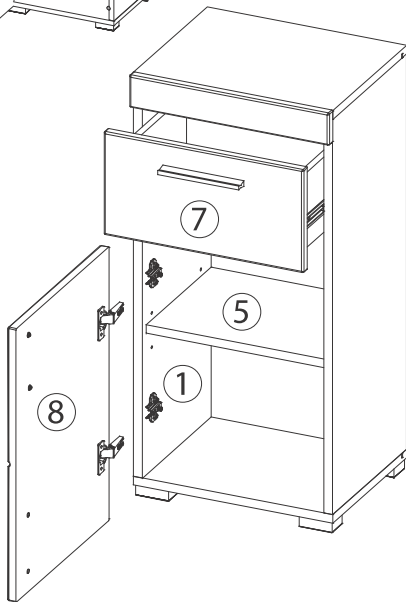
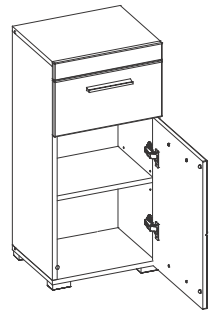



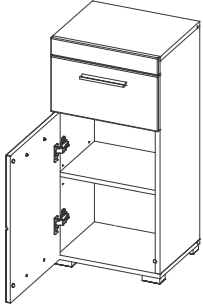

L

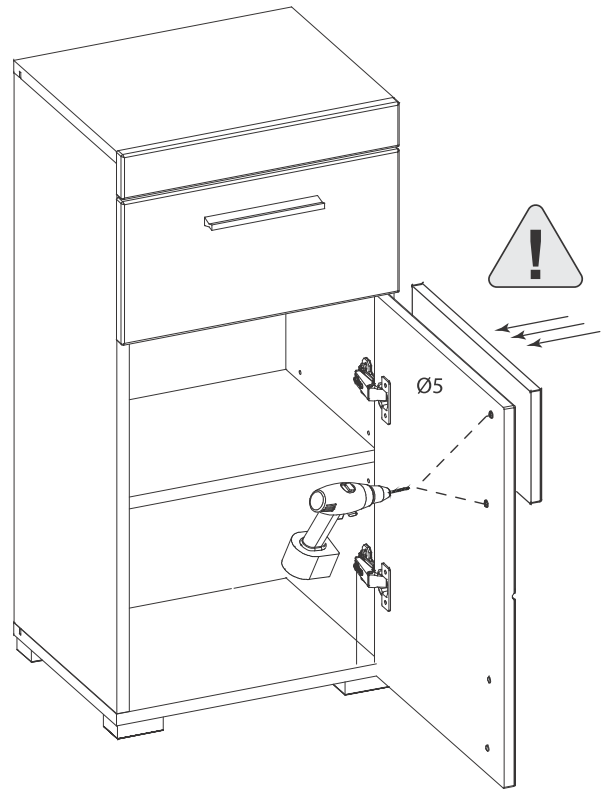
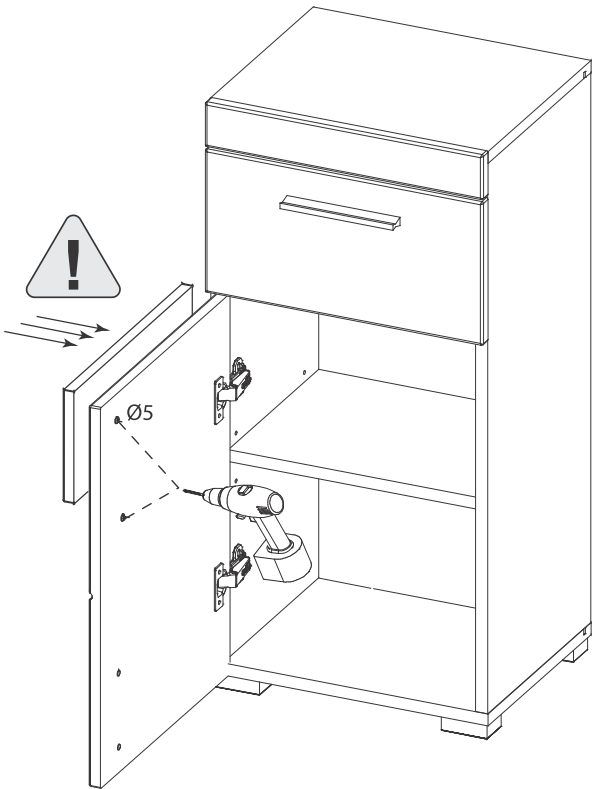
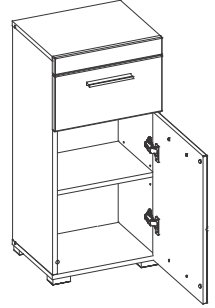

R

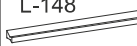

14

 1,5mm U0 x2	 B3 x2	 L-148 L30 x1	 4x25 D18 x2
---	--	--	---

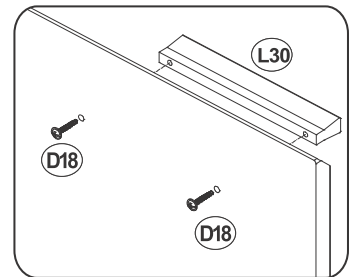
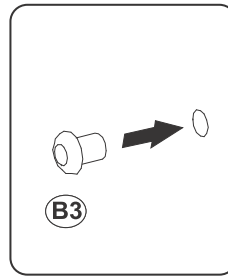
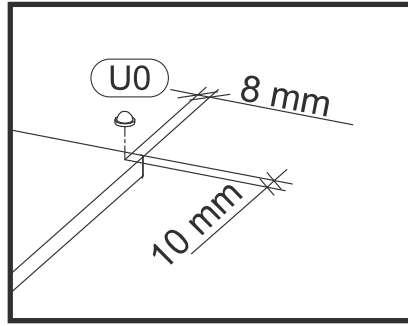
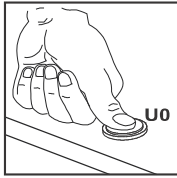
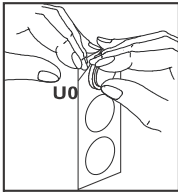

L

R

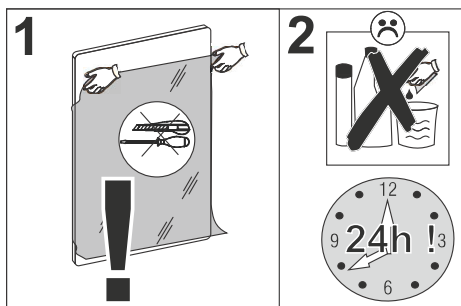
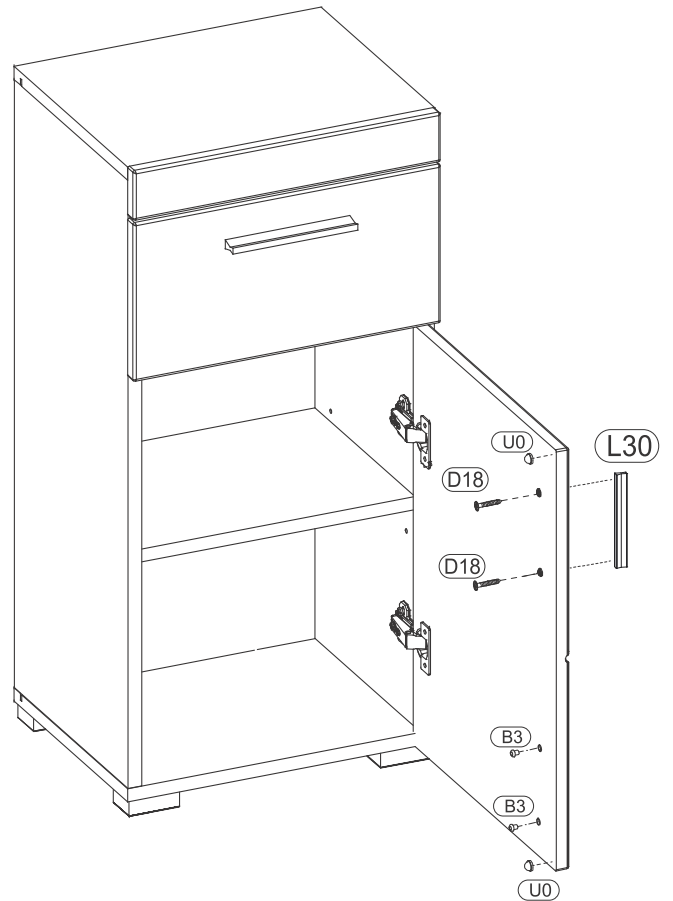
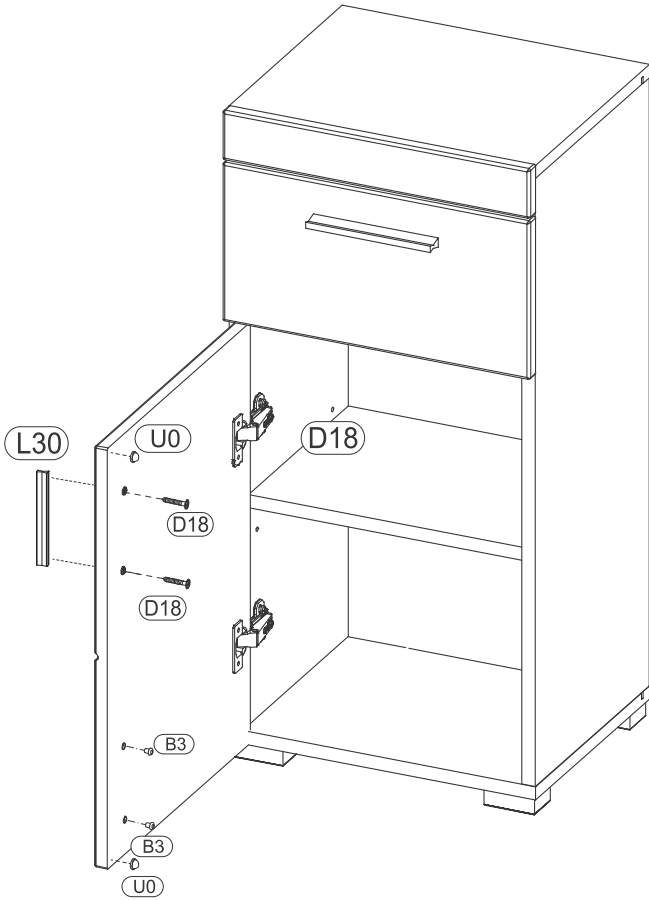
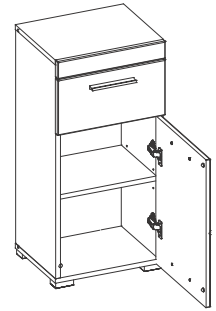
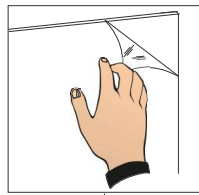
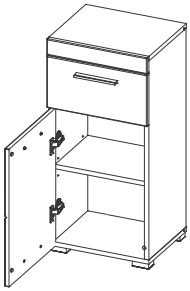

LKZ: X0105

Modellname / Model name / Nom du modèle / Modellnamn / Nome modello / Název modelu / Modelnaam / Ime modela / Numéro Modelo / Modell neve / Название модели / Názov modelu / Ime modela / Denumire model / Наименование на модела / Nazwa modelu

**SNOW**

Modellnummer / Number / Numéro du modèle / Numero / Номер на модела / modello / Číslo modelu / Modell száma / Éislo modelu / Številka modela / Număr model / Broj modela / Modelnummer / Numer modelu

**X19 A9 721**

Type / Tipo / Típus / Тип / Тип / Tip

**721**

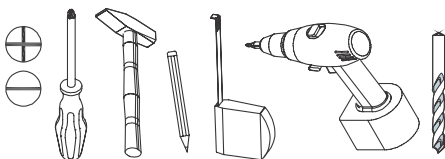
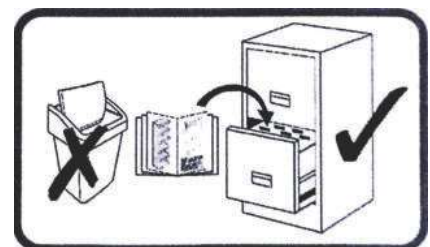
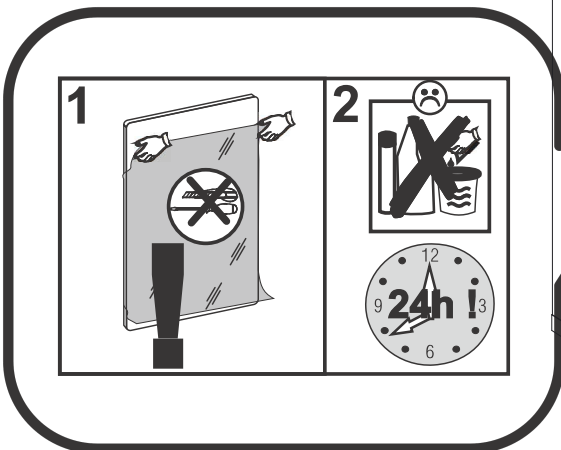
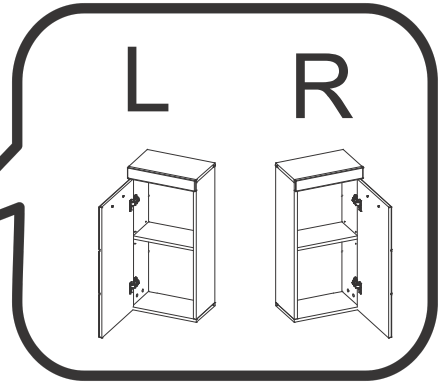
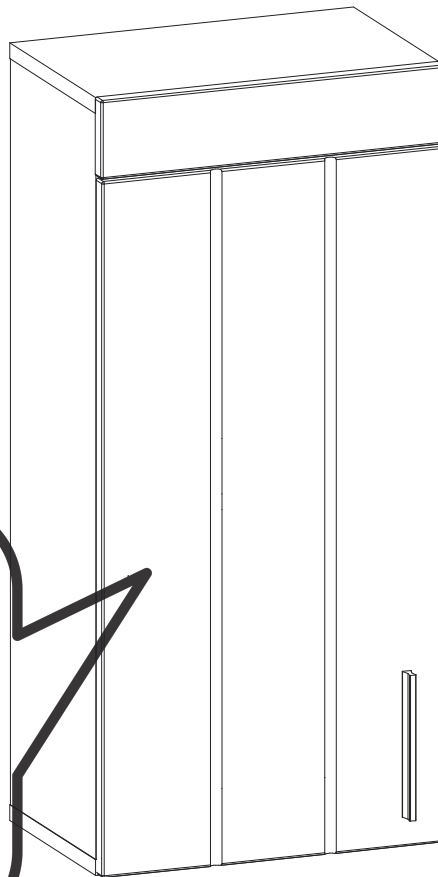
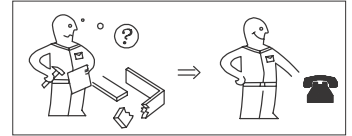
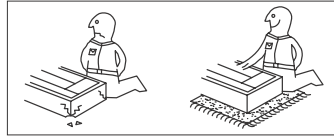
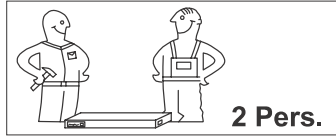

festziehen / tighten / Затягнете / serrer / stringere / utáhnout / vasttrekken / zategnuti / strângere / zwiázac / zacisnaç / szorosan meghúzni / pevne dotiahnut / trdno pritegniti / затянуть / dra át



eindrücken / press in / enfoncer / wcisnaç / ribattere / zatlačit / Вкарайте / indrukken / benyomni / stlačit / vtisniti / tryck in / introducere prin apăsare / вдавить



ausmessen / measure / mesurer / misurare / opmeten / izmeriti / miara / kimérni / izmeriti / mäsurare / измерить / změřit / Измерете / mät upp / zmierzyc



drücken / press / presser / stisknout / Натиснете / vtisniti / nasinac / drukken / pritisnuti / nacinac / pritisniti / нажать / (meg)nyomni / apasare / tryck fast / nacinac



einschlagen / hammer in / beverni / sla in / frapper au marteau / infossare / Zabit / zarazit / Набейте / zabiti / wbić / introducere prin bătaie / забить / zatlouct



Drehen - wenden / przekręcić - odwrócić / Keren - omdraaien / Girare - Ruotare / Okrenuti - ubrnuti / Retourner - renverser / Turn over - turn around / Otočte - obratite / Завъртете - обвърнете / Obrnite list / Introarceji - roții / Vrid runt - vänd / прокрутить - повернуть / otočit - obrátit / elforgatni - megfordítani

Ø8  
Ø5



LKZ: XO105

Modellname / Model name / Nom du modèle / Modellnamn  
Nome modello / Název modelu / Modelnaam / Ime modela  
Número Modelo / Modell neve / Название модели /  
Názov modelu / Ime modela / Denumire model /  
Наименование на модела / Nazwa modelu

**SNOW**

Modellnummer / Number / Numéro du modèle  
Numero / Номер на модела / modello  
Číslo modelu / Modell száma / Eíslo modelu  
Številka modela / Număr model / Broj modela  
Modelnummer / Numer modelu

**X19 A9 721**

Type / Tipo / Típus / Тип / Тип / Tip

**721**

**D** Unser Direktservice für Beschlagteile  
Sollte Ihnen ein Beschlagteil fehlen, können Sie diese Servicekarte  
direkt an die untenstehende Adresse mailen. Wir können allerdings  
nur Beschlagteile auf diesem Wege verschicken. Sollten Sie eine  
andere Beanstandung an Ihrem Möbelstück haben, so wenden sie  
sich bitte direkt an Ihr Möbelhaus.

**GB** Our direct order service for fitting  
If a fitting part is missing, you can e-mail this service card directly  
to the address below. However, we can only send fitting parts in  
this way. If you have any other cause for complaint concerning  
your item of furniture, please contact your furniture store directly.

**CZ** Naše přímé služby pro kování  
Chybí-li vám nějaký díl z kování, můžete tuto servisní kartu odeslat  
e-mailem přímo na níže uvedenou adresu. Touto cestou však  
můžeme rozesílat jen díly kování. Pokud byste reklamovali jiný díl  
nábytku, obraťte se přímo na svého prodejce nábytku.

**F** Bien étudier la notice de montage  
S'il vous manque une ferrure, veuillez envoyer directement la présente  
carte service à l'adresse e-mail indiquée ci-dessous. Cependant, ceci  
nous permet uniquement d'envoyer des ferrures. Pour tout autre type  
de réclamation concernant votre meuble, veuillez contacter  
directement votre magasin d'ameublement.

**I** Il nostro servizio diretto per l'ordine della ferramenta  
Qualora Vi dovesse mancare un pezzo di fissaggio, allora Vi  
preghiamo di inviare questa carta di servizio immediatamente  
all'indirizzo sottostante. Possiamo inviare i pezzi di fissaggio  
solamente per mezzo di questo procedimento. Qualora dovreste  
avere qualche altra reclamazione in merito al mobile, allora Vi  
preghiamo di rivolgerVi direttamente al Vostro Negozio di mobili.

**BG** Нашата директна услуга за обков  
Ако липсват части от комплекта, потърнете настоящата  
сервисна карта и ни я изпратете на e-mail адреса, посочен  
по-долу. По този начин можем да доставяме само липсващи  
елементи от обкова. Ако установите други дефекти по  
мебелите, Ви съветваме да се обърнете към мебелната  
къща/магазин, от който сте закупили стоката.

**NL** Onze directservice voor losse onderdelen  
Wanneer er een onderdeel ontbreekt, kunt u deze servicekaart  
direct aan onderstaand e-mailadres sturen. Wij kunnen langs deze  
weg echter alleen beslagdelen versturen. Mocht u een ander  
probleem aan uw meubel hebben, verzoeken wij u contact op te  
nemen met uw meubeldealer.

**PL** Nasz bezpośredni serwis części montażowych  
Jeżeli brakuje części koniecznych do montażu, prosimy o przesłanie  
nam niniejszej karty serwisowej na niżej podany adres e-mailowy.  
W ten sposób możemy przesyłać Państwu tylko brakujące części.  
W przypadku innych reklamacji dotyczących mebla, prosimy zgłosić  
się do salonu meblowego, w którym został dokonany zakup.

**HR** Servis za okove  
U slučaju da nedostaje neki od dijelova molimo vas da na dolje  
navedenu mail adresu pošaljete ovaj servisni obrazac. Na ovaj način  
mogu se dostaviti samo okovi. U slučaju da imate dodatne prigovore  
vezane uz komad namještaja molimo vas da se obratite izravno  
trgovini namještaja gdje je isti kupljen.

**HU** Direktszolgáltatunk vasalatok esetén  
Ha hiányzik egy vasalat, ezt a kártyát közvetlenül elküldheti az  
alább található címre. Azonban csak vasalatoskat tudunk így  
küldeni. Amennyiben másfajta reklamáció áll fenn bútordarabját  
illetően, forduljon közvetlenül a bútordízhöz.

**SK** Naš priamy servis pre časti kovania  
Ak by Vám chýbala nejaká časť kovania, môžete poslať  
túto servisnú kartu pošťou e-mailom na nižšie uvedenú  
adresu. Diely kovania vieme poslať iba týmto spôsobom.  
Ak by ste mali inú reklamáciu ohľadom Vášho nábytku,  
obráťte sa priamo na Vašu predajňu nábytku.

**SLO** Naše direktne uslužne storitve za okovje  
Če vam manjka kakšno okovje, lahko to servisno kartico pošljete  
po e-pošti direktno na spodnji naslov. Po tej poti vam lahko  
pošljemo samo okovje. Če želite reklamirati kakšen drug del  
pohištva, se obrnite neposredno na vašo trgovino pohištva.

**RO** Service-ul nostru direct pentru feronerie  
În cazul în care vă lipsește o piesă de feronerie puteți să trimiteți  
direct acest card de service prin e-mail la adresa de mai jos. Noi  
nu putem expedia piese de feronerie decât pe această cale.  
Dacă aveți o altă reclamație referitoare la piesa de mobilier,  
atunci vă rugăm să vă adresați direct la magazinul dvs. de mobilă.

**RUS** Наш прямой сервис для поставок фурнитуры  
Если окажется, что Вам не хватает того или иного элемента  
фурнитуры, Вы можете отправить сервисную карту по факсу  
непосредственно на нижеприведенный адрес электронной  
почты. Однако, таким образом мы можем пересылать лишь  
фурнитуру. Если же у Вас возникнут иные претензии относительно  
приобретенной мебели, пожалуйста, обращайтесь  
непосредственно в организацию, осуществившую продажу.

**S** Vår direktservice för beslagsdelar  
Om du saknar en beslagsdel kan du skicka detta servicekort direkt  
till e-postadressen som anges nedan. Tänk på att detta är den enda  
möjligheten att skicka beslagsdelar till dig. Om du vill reklamera din  
möbel av en annan anledning måste du kontakta ditt möbelhus direkt.

**ES** Nuestro servicio directo para accesorios  
Si le falta algún accesorio, puede enviar esta tarjeta de servicio directamente  
a la siguiente dirección. No obstante, por este método solo podemos  
enviar accesorios. Si tiene alguna otra objeción sobre su mueble, consulte  
directamente con su mueblería.

**TR** Donatılar için doğrudan servisimiz  
Bir donatınız eksikse bu servis kartını doğrudan aşağıda bulunan adrese  
doğrudan mail yazabilirsiniz. Sadece bu yolla donatıları gönderebiliriz.  
Mobilyanızda başka şikayetleriniz varsa lütfen doğrudan mobilya satıcınıza  
danışın.

max.

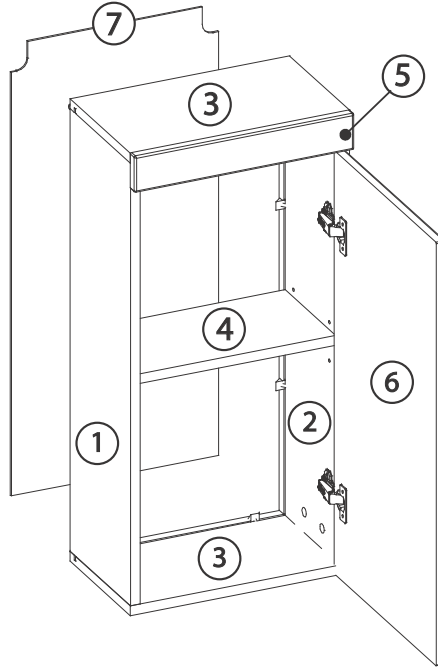

Nr.	Maße mm			Colli	Anzahl
1	758	224	16	1/1	1
2	758	224	16	1/1	1
3	364	224,5	16	1/1	2
4	331	194	16	1/1	1
5	361	80	16	1/1	1
6	707	362	16	1/1	1
7	768	341	2,5	1/1	1
B1				1/1	1

Grund der Beanstandung / Reason of the objection:

Möbelhaus / Furniture store:

Name / Name: Telefon / Telephone:

PLZ / postal code: Ort / City:

Strasse / Street:

Haus-Nr. / House No.: @E-Mail:

E-Mail Kundenservice / Customer service e-mail / E-mail servisního střediska / E-mail de notre service clientèle / e-mail servizio clienti / E-mail на отдела за  
обслужване на клиенти / E-mail klantenservice / E-mail servisu dla klientów / Servisna mail adresa / Az ügyfélszolgálat e-mail címe / E-mail zákaznického  
servisu / E-pošta Servisna služba / E-mail Serviciu clienți / E-Mail сервисной службы / E-postadress kundservice / Servicio de atención por correo electrónico / Müşteri hizmetleri e-postası

service@xonox-home.com  
Hotline xonox.home GmbH  
0049-(0)5261-92020800

LKZ: XO105

Modellname / Model name / Nom du modèle / Modellnamn  
Nome modello / Název modelu / Modelnaam / Ime modela  
Numéro Modello / Modell neve / Название модели /  
Názov modelu / Ime modela / Denumire model /  
Наименование на модела / Nazwa modelu

**SNOW**











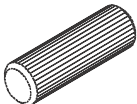
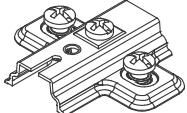
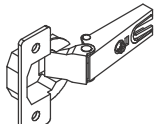

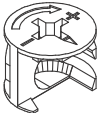
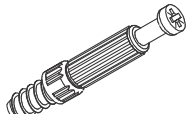

Modellnummer / Number / Numéro du modèle  
Numero / Номер на модела / modello  
Číslo modelu / Modell száma / Ěíslo modelu  
Številka modela / Număr model / Broj modela  
Modelnummer / Numer modelu

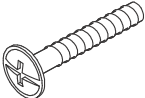
**X19 A9 721**

Type / Tipo / Típus / Typ / Тип / Tip

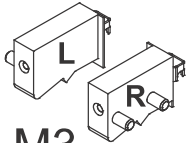
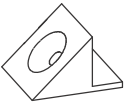
**721**

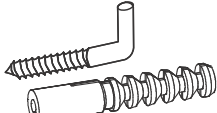
# B1

 <b>A0</b> x8	 <b>G1B</b> x2	 <b>G1A</b> x2	<b>4 x 16 mm</b>  <b>D10</b> x4	 <b>H0</b> x4	<b>3x15</b>  <b>D0</b> x8
 <b>C1</b> x8	 <b>C2</b> x8	<b>L-148</b>  <b>L30</b> x1	<b>4x25</b>  <b>D18</b> x2	<b>3,5x16</b>  <b>D17</b> x8	 <b>C0</b> x8
 <b>B3</b> x6	 <b>M3</b> x1	 <b>F0</b> x8	 <b>1,5mm</b> <b>U0</b> x2	 <b>E1</b> x2	 <b>F1</b> x2

1

8x35 A0 x8	H0 x4	C1 x8	C2 x8
3,5x16 D17 x4	M3 x1	F1 x2	

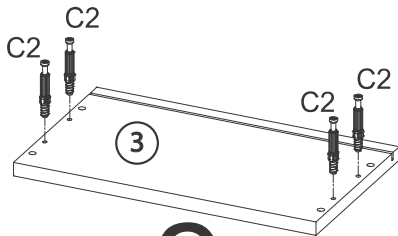
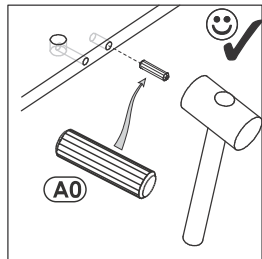
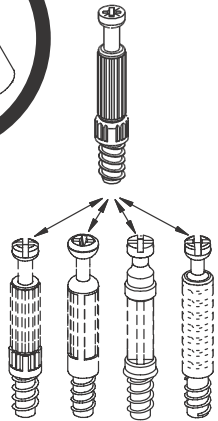
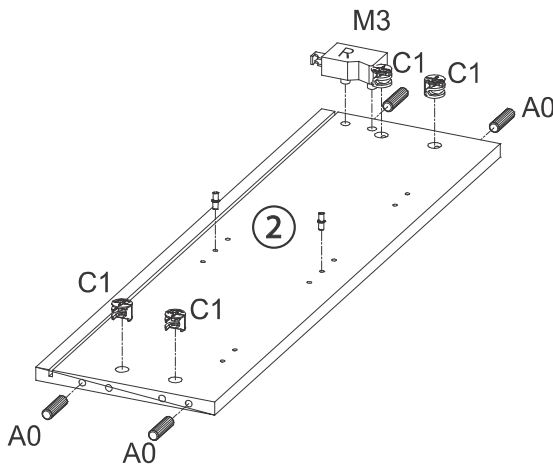
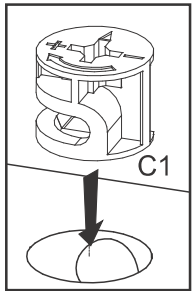
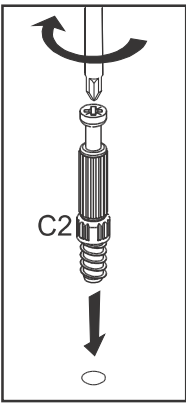
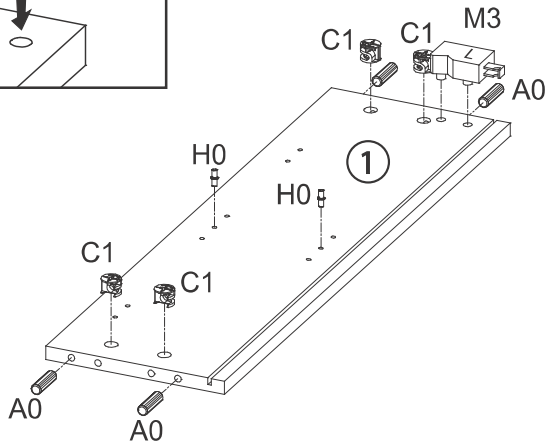
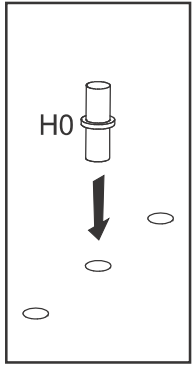
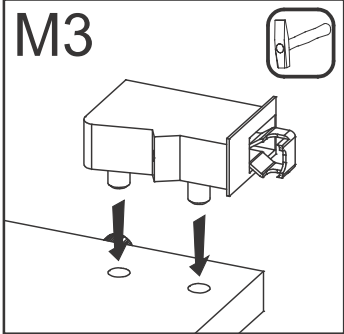
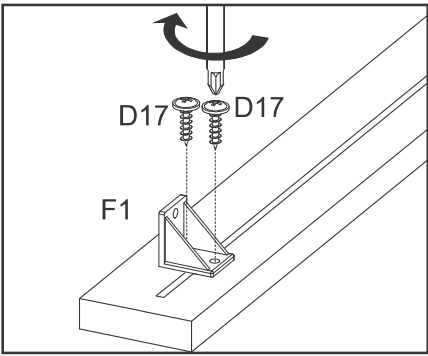

x2

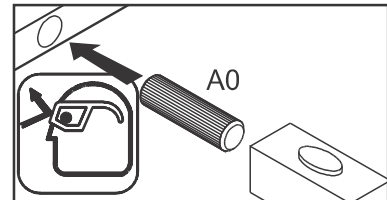
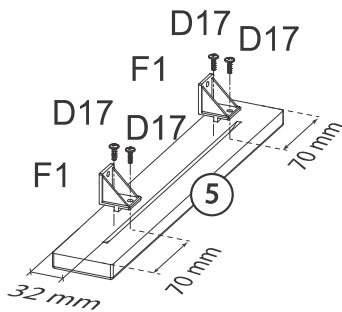



2

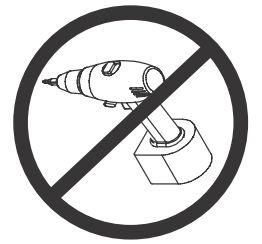
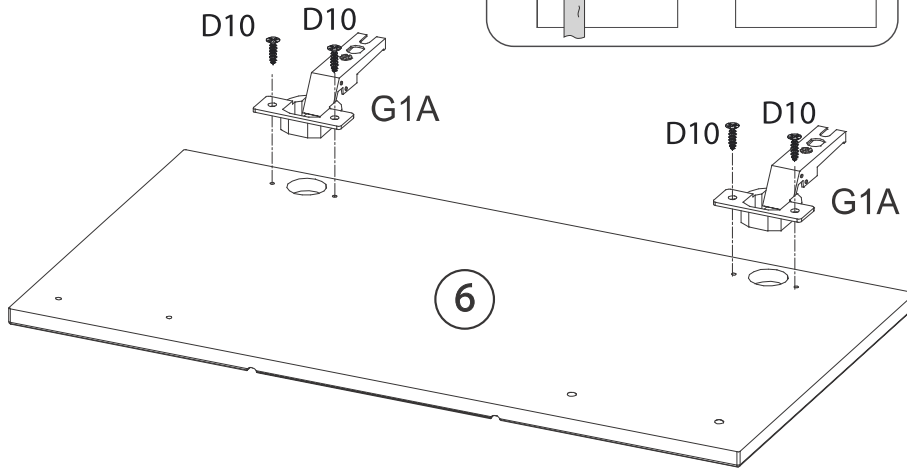
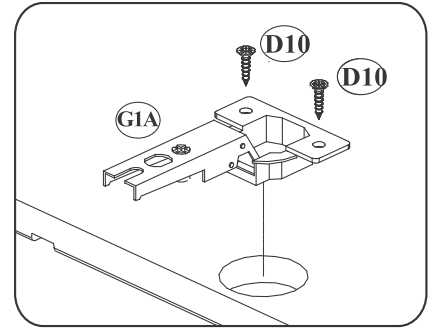
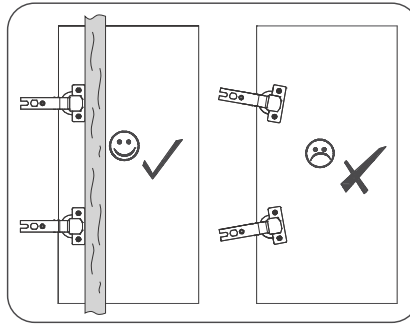
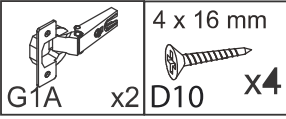

3

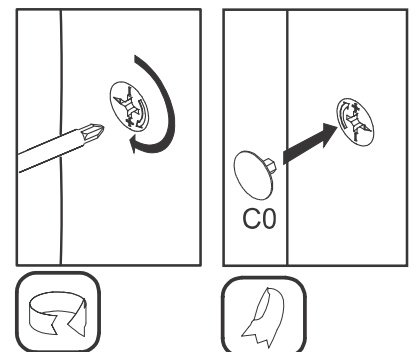
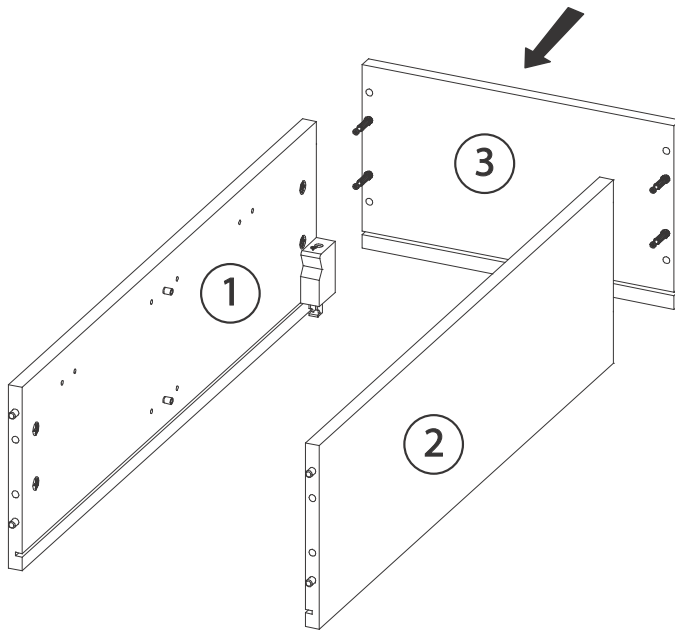
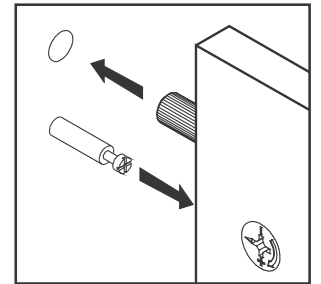
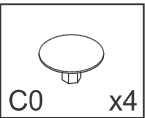

4

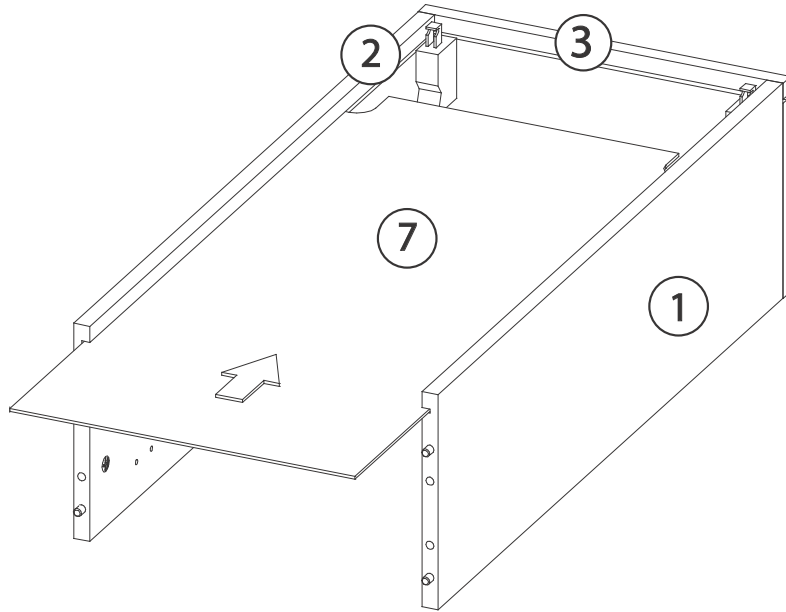

5

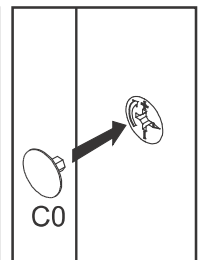
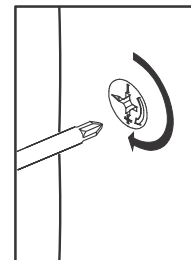
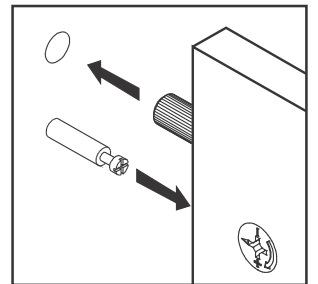
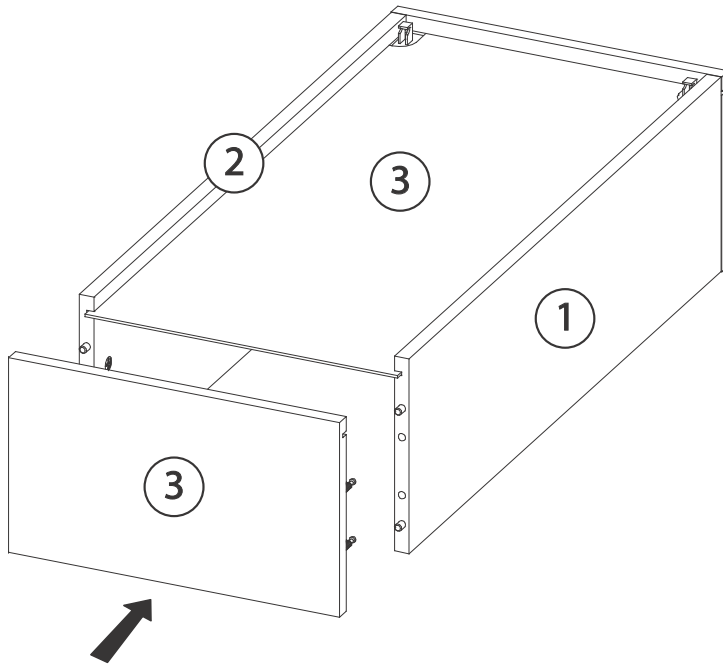
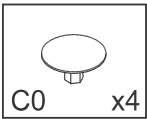

6

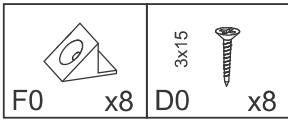

A=B

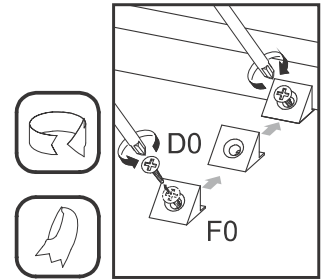
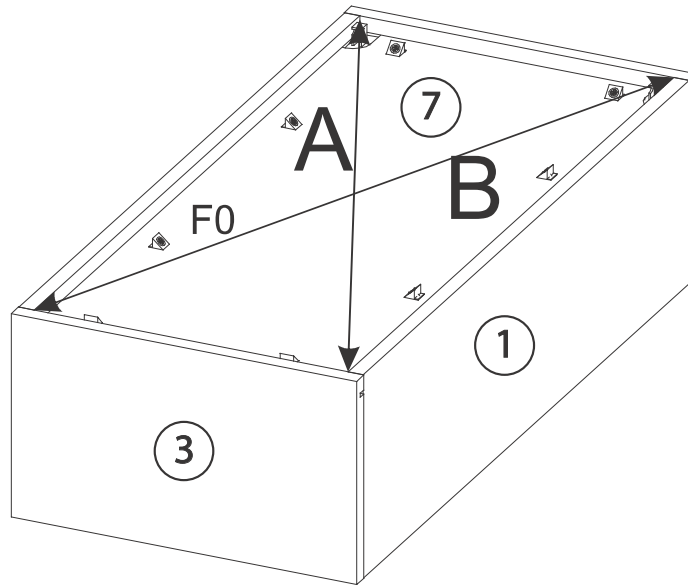

7

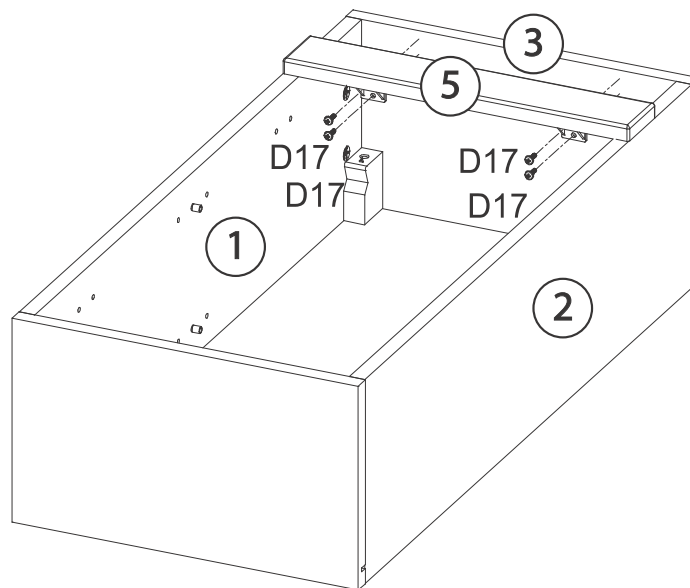
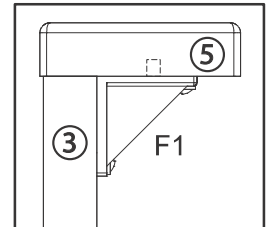
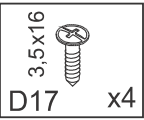

8

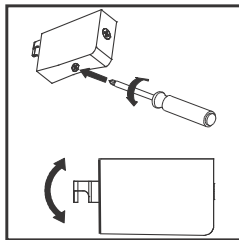
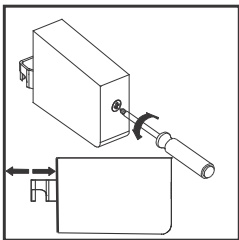
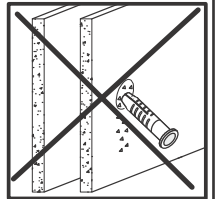
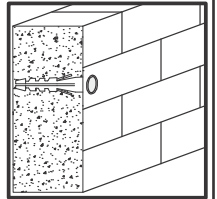
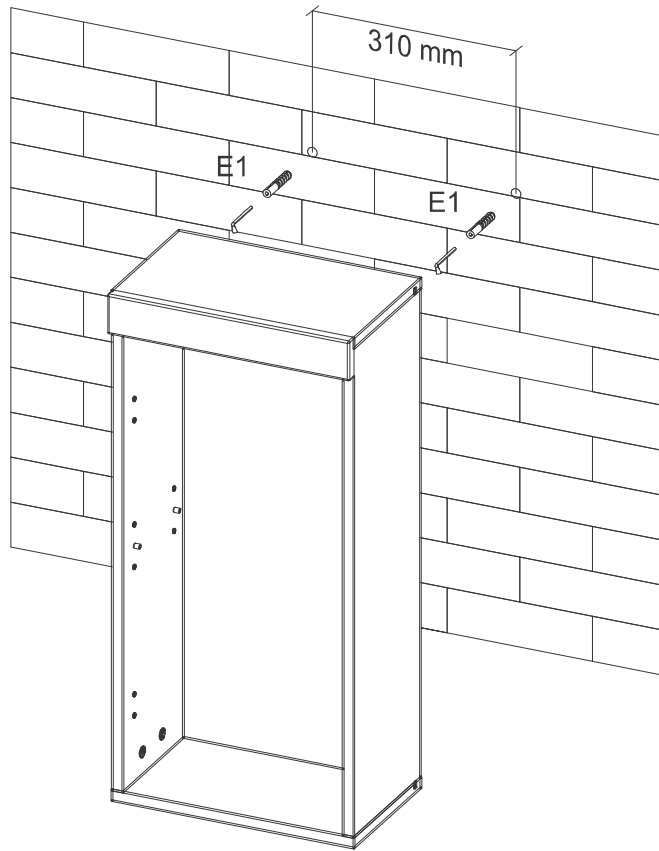
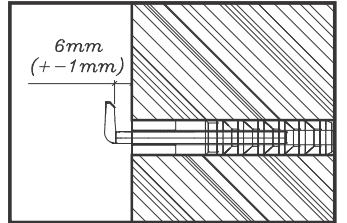
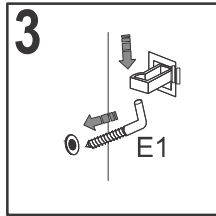
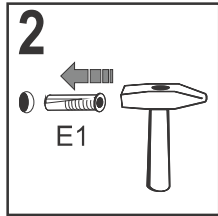
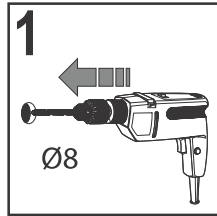
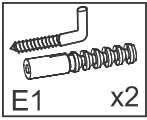

9

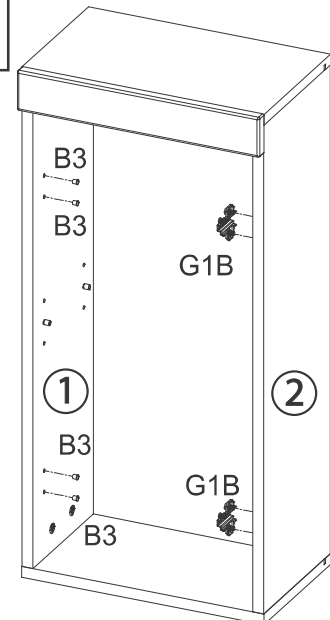
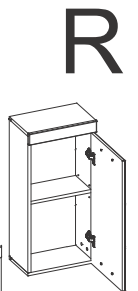
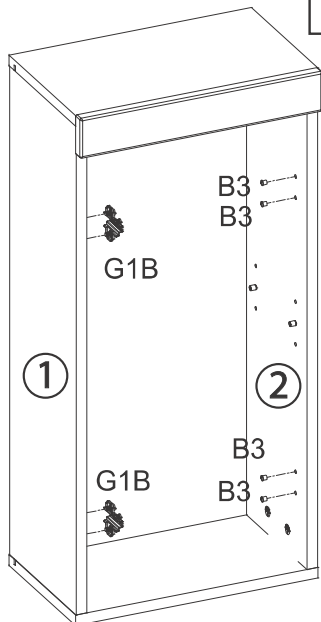
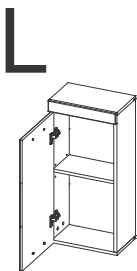
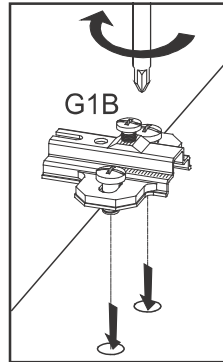
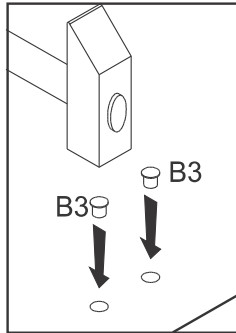
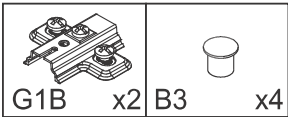

10

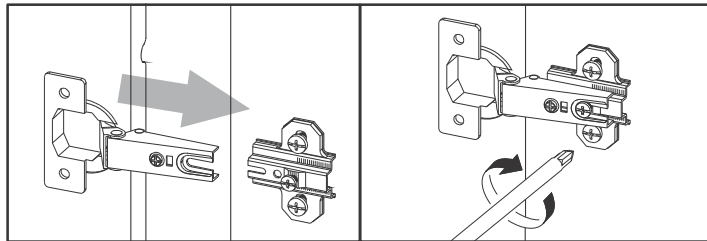

L



R

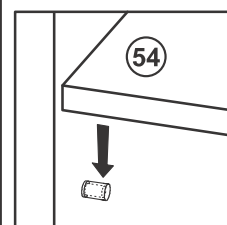
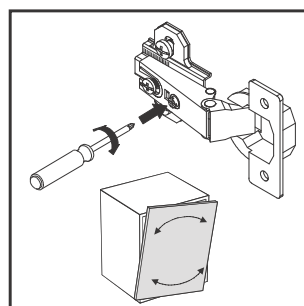
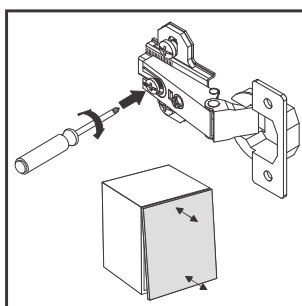
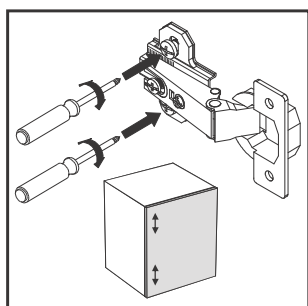
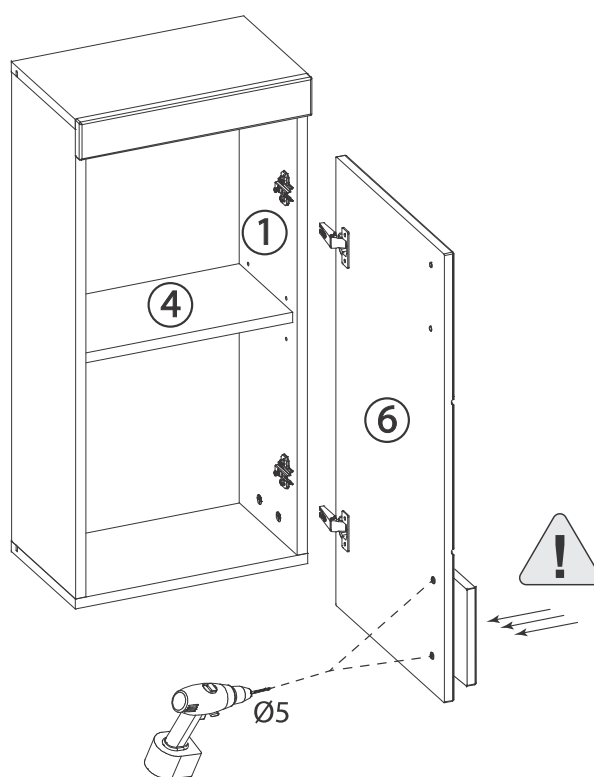
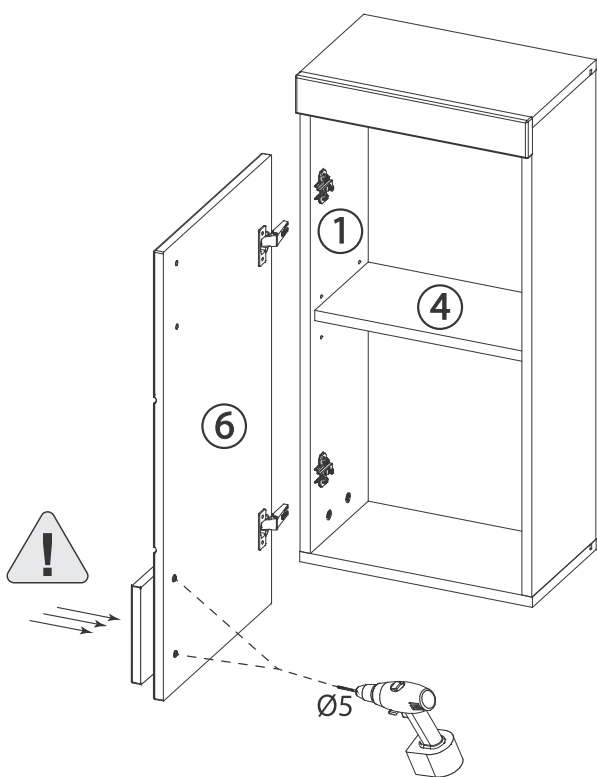
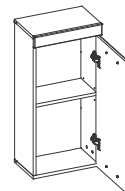
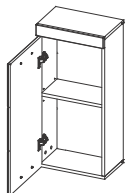

12

L-148	4x25				
L30	x1	D18	x2	B3	x2
				U0	1,5mm x2

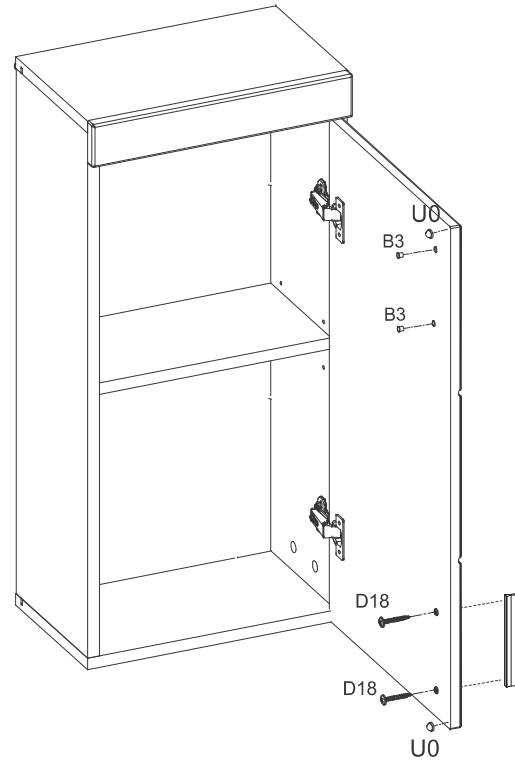
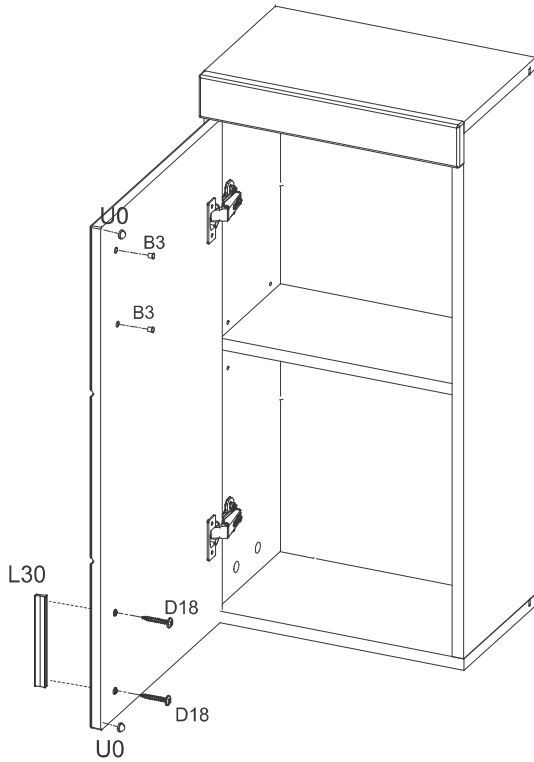
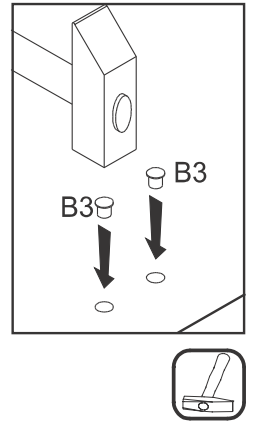
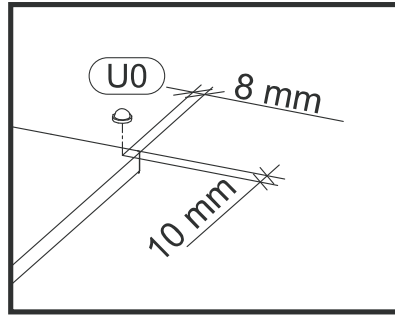
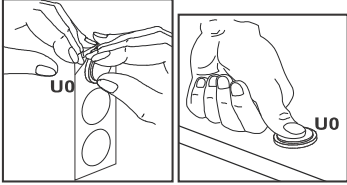

L

R

