

# 80-20101-40

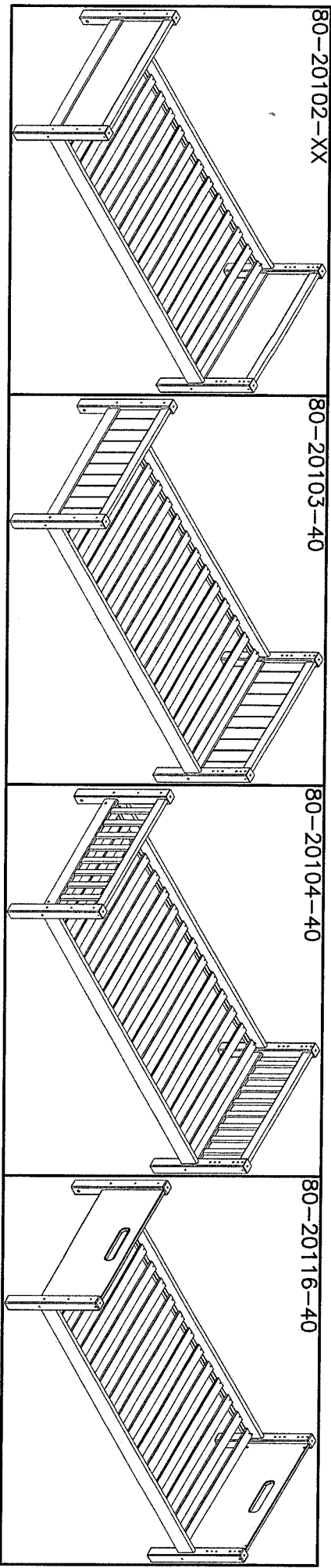

See assembly instruction in box no.  
 Voir notice de montage dans la caisse no.  
 Siehe Aufbauanleitung im Karton no.  
 Zie voor de montage-instructie pakketnr.

Before assembling this product, please ensure that all the components supplied comply with the list on this page. All Screw-type fittings can be tightened with this tool.

Avant de commencer l'assemblage, veuillez confirmer si tous les objets indiqués sont présents. Tous les vis peuvent être serrés par cet outil.

Bevor Sie mit dem Aufbau beginnen, kontrollieren Sie ob alle auf der Zeichnung angegebenen Teile vorhanden sind. Bitte verwenden Sie zur Montage einen Kreuzschraubzieher und den beiliegenden Insechschlüssel.

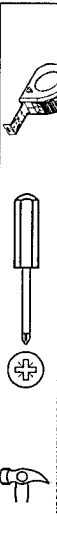

Ware-nr.  
Part no.  
Ref No

Stück  
Qty.  
Qté

Mass  
Dim.

Siehe Bild-nr.  
See picture no.  
Image no

12-05305473-40	2 stick/pcs	12-08305474-40	2 stick/pcs	1305-19672-40	2 stick/pcs
A		B		C	
3922-08018	8 stick/pcs	647x63x63	3930-10050	16 stick/pcs	3909-70100
647x63x63		647x63x63		4 stick/pcs	3901-40030
Z1	M8/ø12x18 mm	Z2	ø10x50 mm	Z3	16 stick/pcs
3913-08110		8 stick/pcs	3938-000081-2	20 stick/pcs	3938-00010-2
Z5	M8x110 mm	Z6	ø8 mm	Z7	ø10 mm
				Z8	ø16 mm
				Z4	64x30 mm
					4 stick/pcs
					4033-005
					1 stick/pcs
					5 mm
					1967x115x26

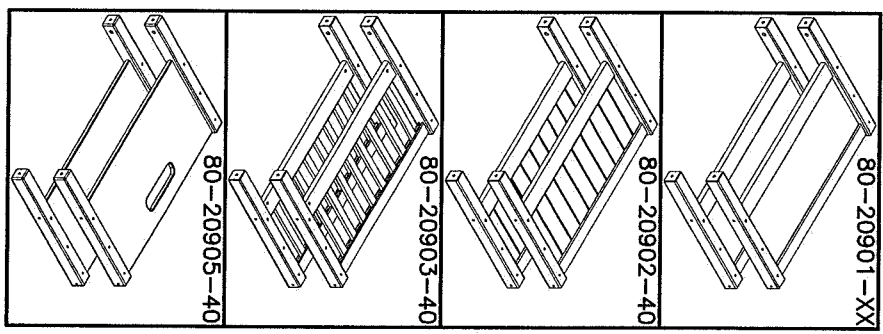

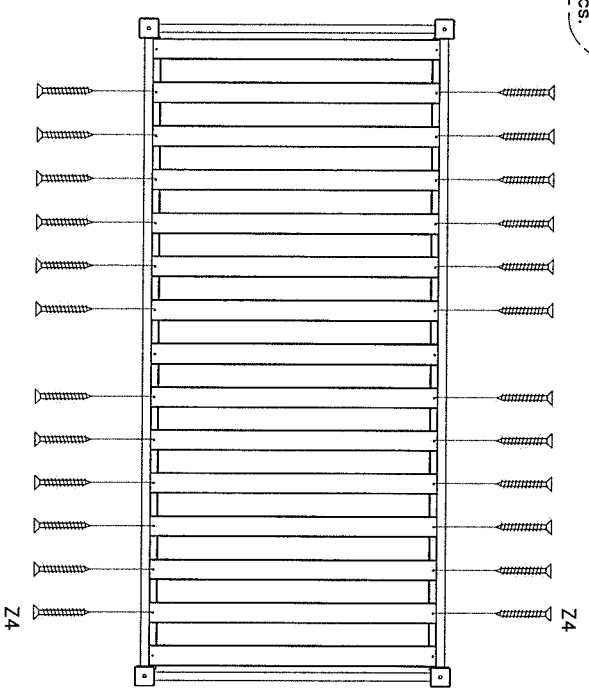
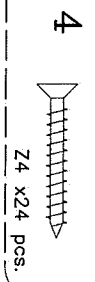
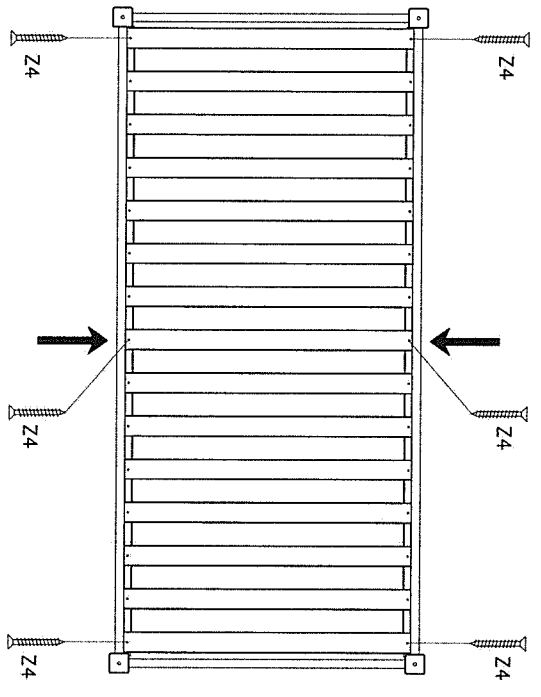
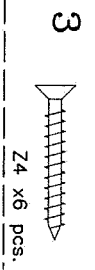
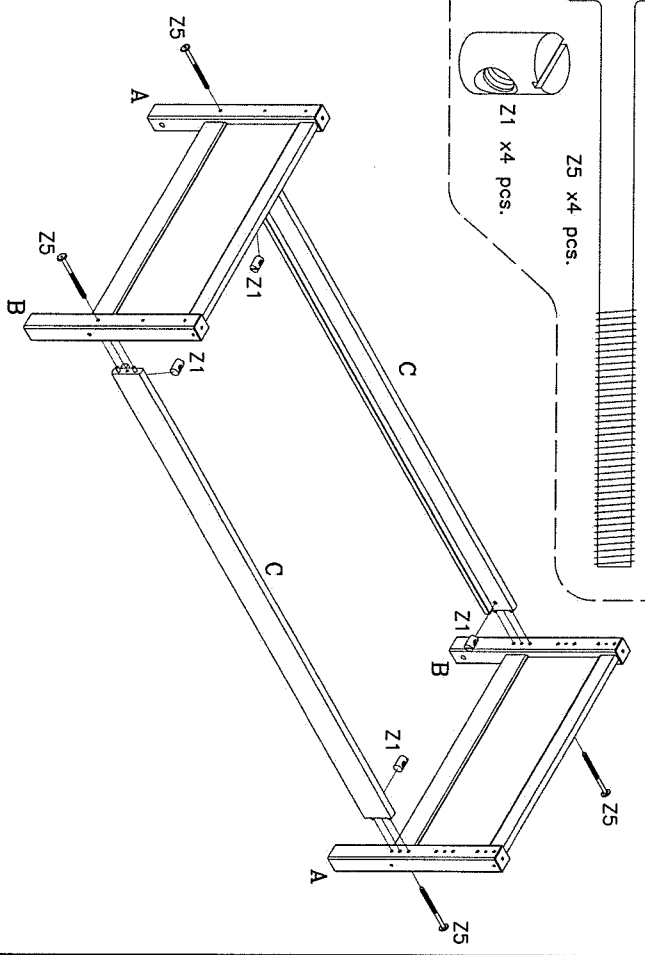
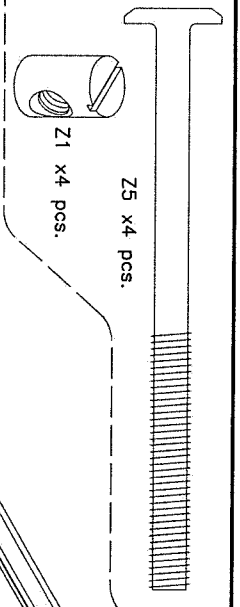
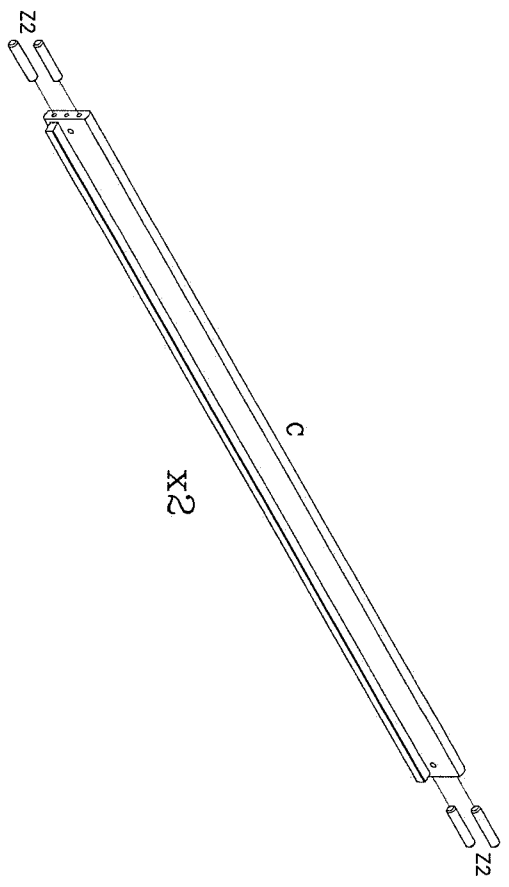
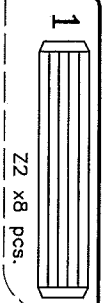

# 80-20905-40 White

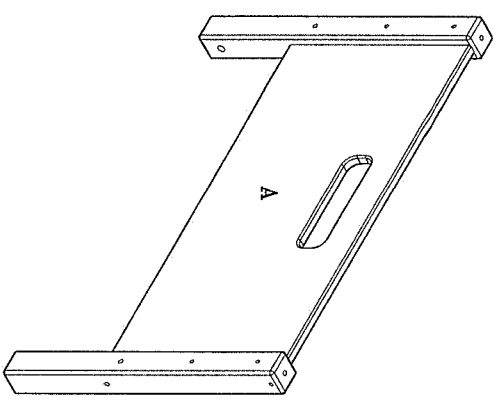

Before assembling this product, please ensure that all the components supplied comply with the list on this page. All Screw-type fittings can be tightened with this tool.

Avant de commencer l'assemblage, veuillez vérifier si tous les objets inclus sur cette page sont de type vis à serrer et peuvent être serrés par cet outil.

Bevor Sie mit dem Aufbau beginnen, kontrollieren Sie bitte alle Komponenten auf angegebene Teilzeichnungen sind. Bitte verwenden Sie zur Montage einen Kreuzschraubenzieher und den beiliegenden Innensechskantschlüssel.

Vire-nr. Part no. Ref No. Stock Qty. Qté.

Siehe Bild-nr. See picture no. Image no. Mass Dim. Dim.

4301-2208631-40	2 stick/pcs.		M6/Ø10x18mm	4 stick/pcs. 4033-004	1 stick/pcs. 4 mm.
			M6x110 mm.		

Z1, Z2, Z5 Fittings in single / bunk bed box.  
 Z1, Z2, Z5 Beschläge im Einzel- / Etagenbett Karton.  
 Z1, Z2, Z5 Raccords en lit simple / lit superposé.  
 Z1, Z2, Z5 Fittings in het enkelspel / stapelbed boxen.

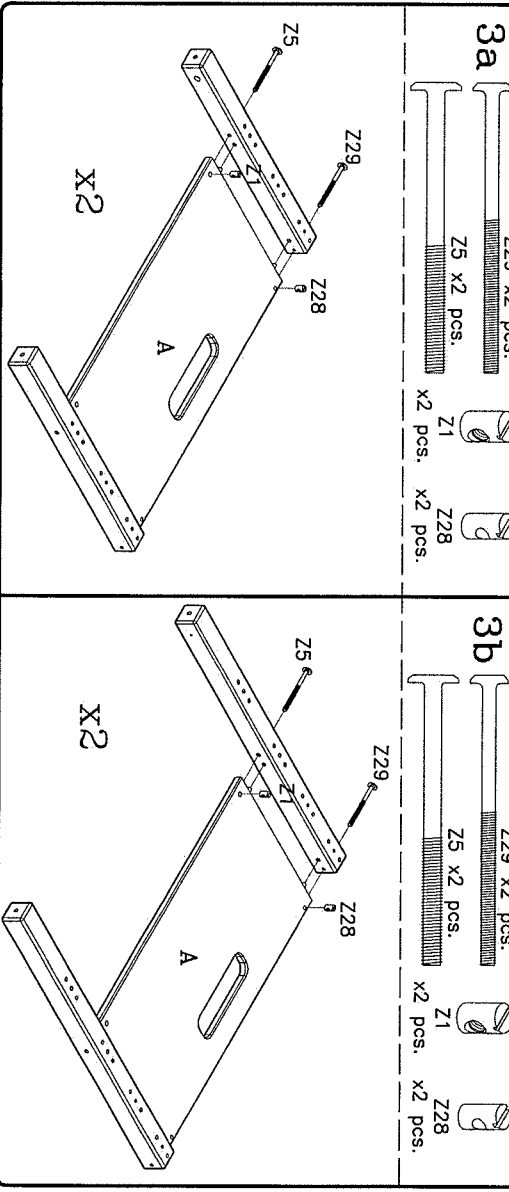
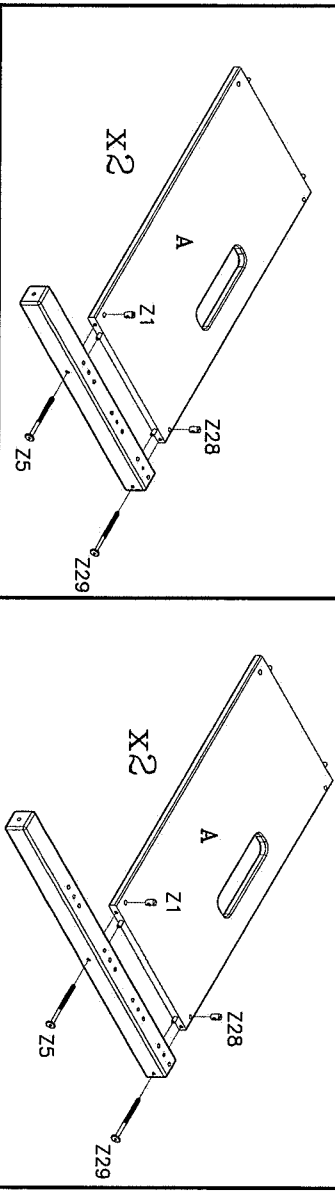
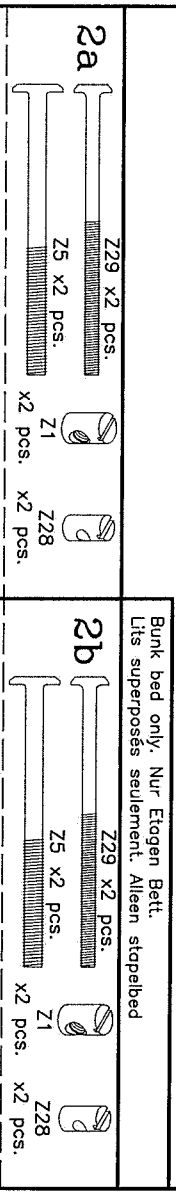
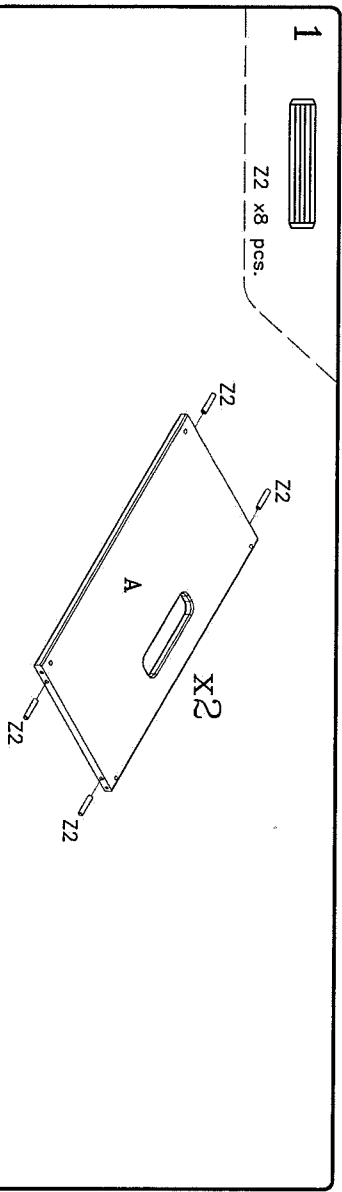

# 80-20401-40

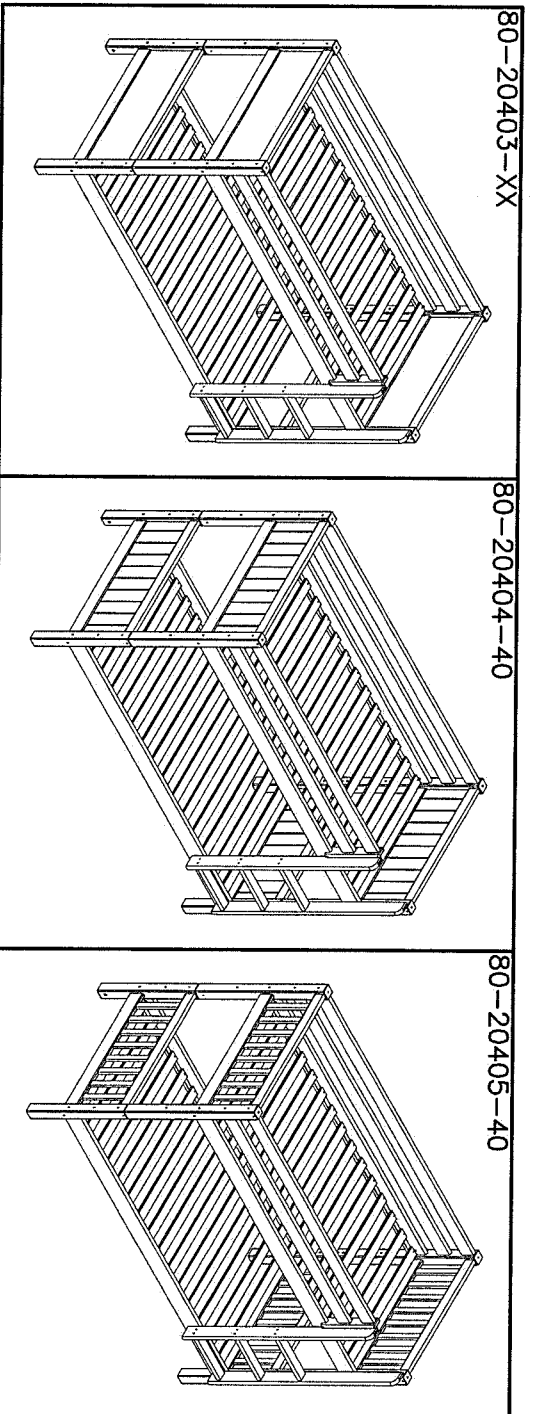

Before assembling this product, please ensure that all the components supplied comply with the list on this page. All Screw-type fittings can be tightened with this tool.

Avant de commencer l'assemblage, veuillez contrôler si tous les objets indiqués sont présents. Tous les vis peuvent être serrés par cet outil.

Bevor Sie mit dem Aufbau beginnen, kontrollieren Sie ob alle auf der Zeichnung angegebenen Teile vorhanden sind. Bitte verwenden Sie zur Montage einen Kreuzschraubzieher und den beiliegenden Innesschlüssel.

12-02603182-40 3 stick/pcs. 12-02612641-40 2 stick/pcs. 12-02619676-40 2 stick/pcs. 12-02630865-40 2 stick/pcs.

A 12-02603511-40 1 stick/pcs. 318x65x26 D 126x89x26 F 1305-19672-40 2 stick/pcs. 1967x89x26 H 865x63x63 2 stick/pcs.

B 3922-08018 8 stick/pcs. 361x65x26 E 3909-70100 157x89x26 G 10 stick/pcs. 3901-40030 1967x115x26 I 40 stick/pcs. 3913-08110 865x63x63 Z6 8 stick/pcs. 3903-40025 2 stick/pcs. 3907-63022 2 stick/pcs.

Z1 M8/ø12x18 mm. 4007-014 4 stick/pcs. Z2 ø10x50 mm. 4008-021 2 stick/pcs. Z3 3909-70060 14 stick/pcs. Z4 ø7x100 mm. 3901-30020 4 stick/pcs. Z5 ø4x30 mm. 3908-70050 4 stick/pcs. Z6 M8x110 mm. 3907-63022 2 stick/pcs. Z7 ø8 mm. 3938-00010-2 32 stick/pcs. Z8 ø4x25 mm. 3907-63022 2 stick/pcs. Z9 ø10x80 mm. 4007-014 4 stick/pcs. Z10 ø6,3x22 mm. 3907-63022 2 stick/pcs.

Z12 15,5x3 mm. Z13 20x20x16x2 mm. Z15 ø7x80 mm. Z18 ø3x20 mm. Z20 ø7x50 mm. Z21 ø10x80 mm.

Ware-nr. Part no. Ref No. Stick. Qty. Qte. Mess. Dim. Siehe Bild-nr. See picture no. Image no.

See assembly instruction in box no. 80-20101-40

Voir notice de montage dans la caisse no. 80-20101-40

Siehe Aufbauanleitung im Karton no. 80-20101-40

Zie voor de montage-instructie pakkeotr. 80-20101-40

3938-00010-2 16 stick/pcs. 3938-00010-2 32 stick/pcs.

ø8 mm. Z7 3907-63022 2 stick/pcs. ø10 mm. 3907-63022 2 stick/pcs.

ø4x25 mm. Z10 ø6,3x22 mm.

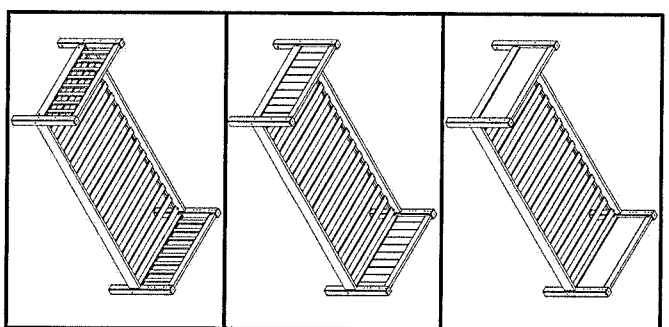

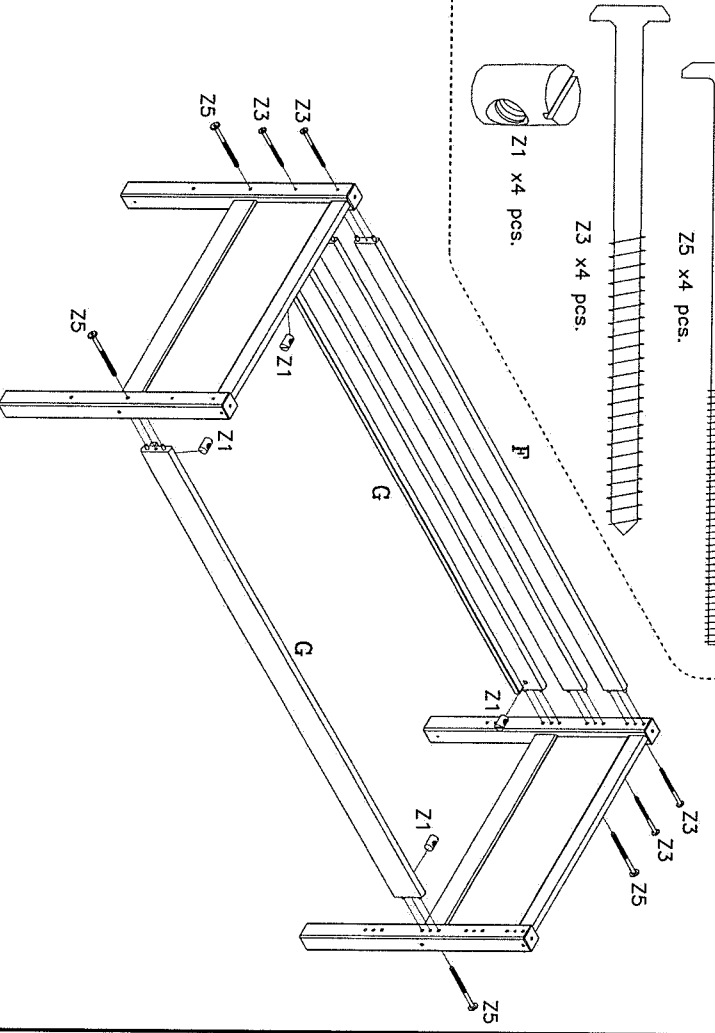
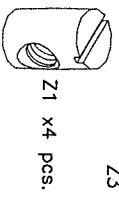
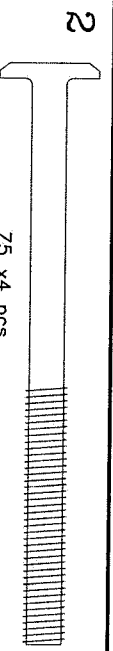
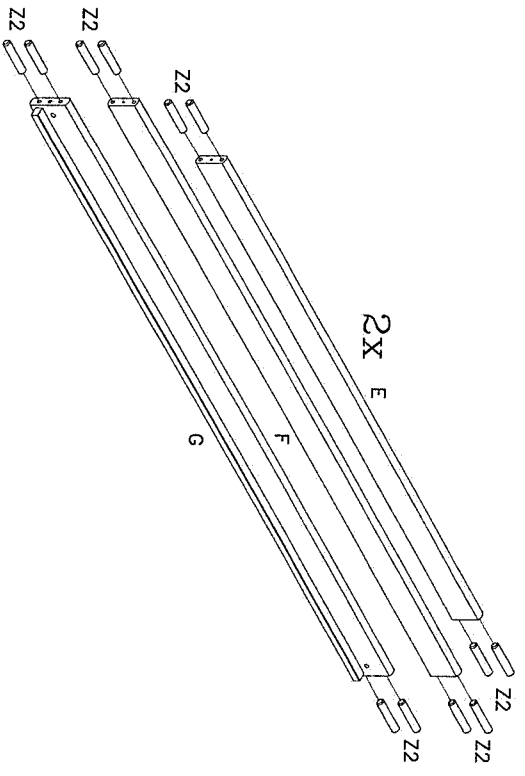

3

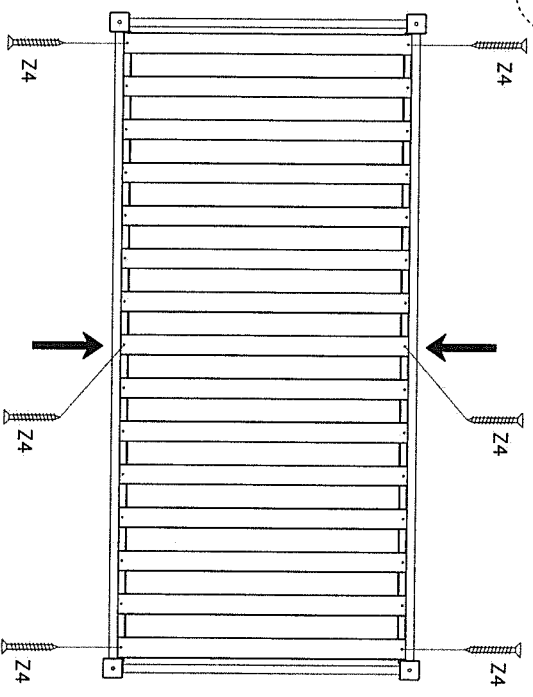

4

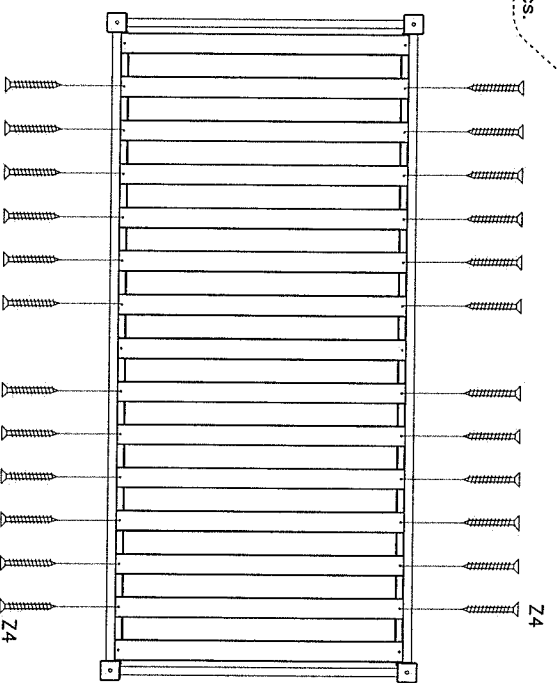

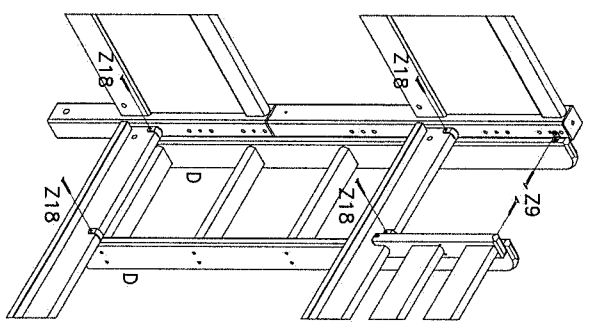
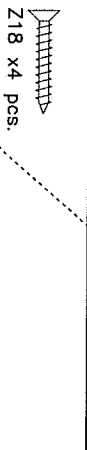
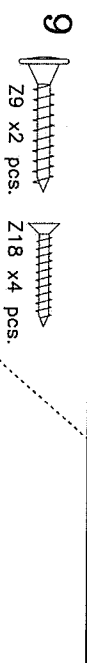
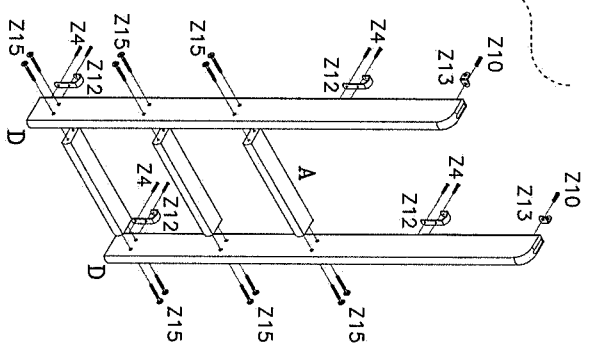
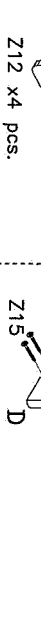
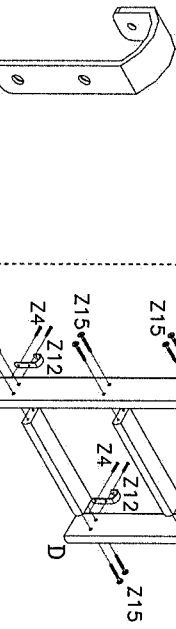
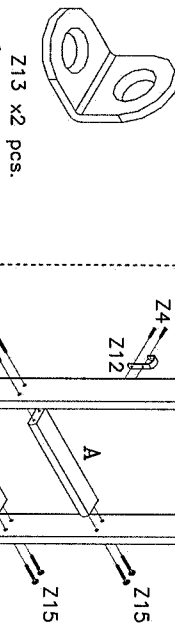
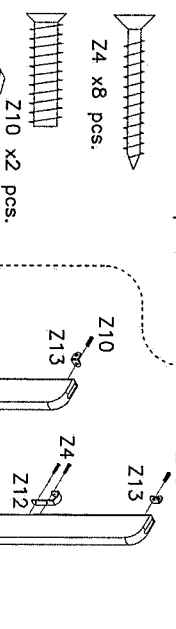
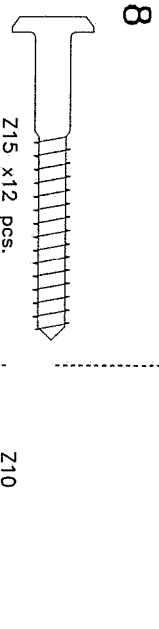
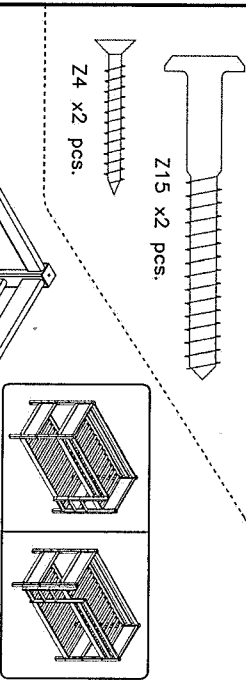
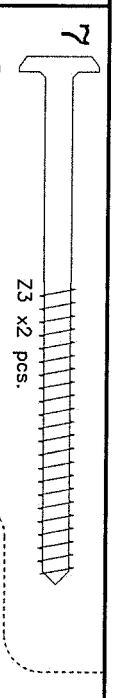
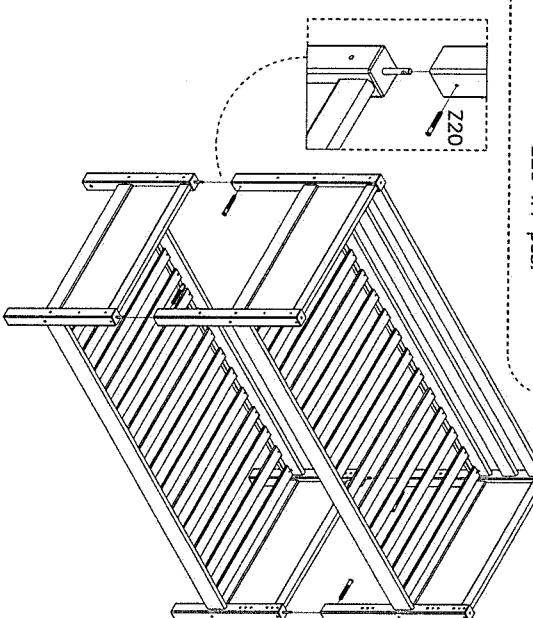
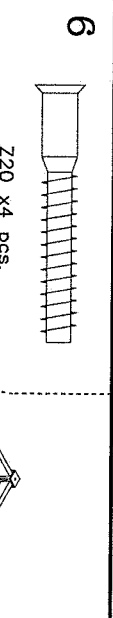
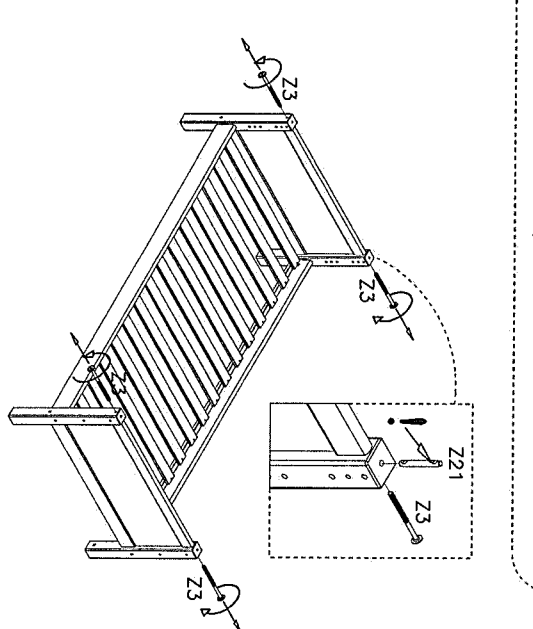
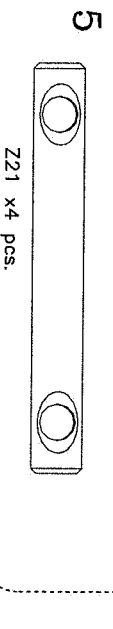

DK: Max. madrashøjde  
 D: Max. Höhe der Matratze  
 GB: Max. height of mattress  
 F: Hauteur max. du matelas  
 I: Altezza max. materasso  
 E: Altura del colchon máximo  
 NL: Maximale matrashoogte  
 CN: 床垫最大高度



Bunk bed as 2 single beds.

Etagenbett als 2 Einzelbetten.

Comme 2 lits simple.

Stapelbed gemaakt in 2 eenpersoonsbedden.

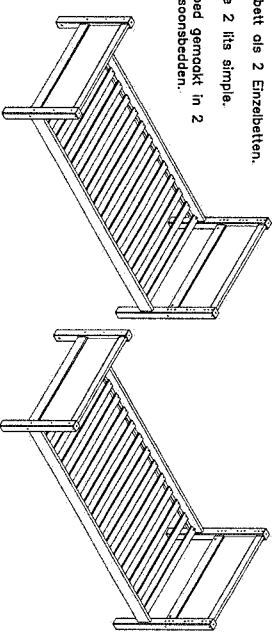









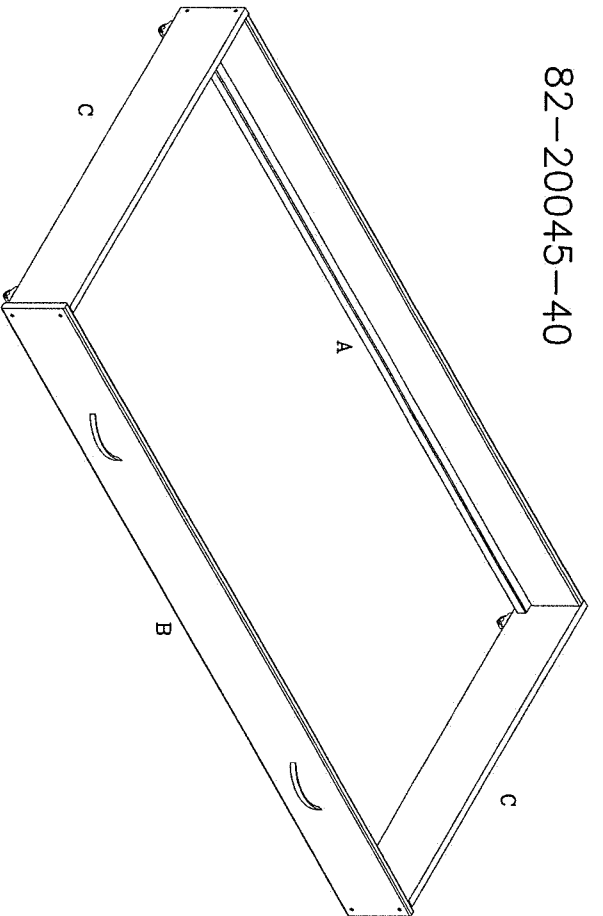





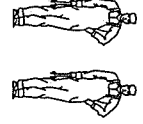



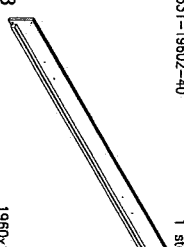
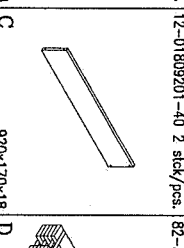
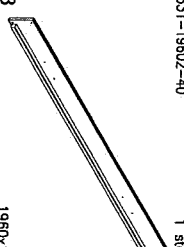
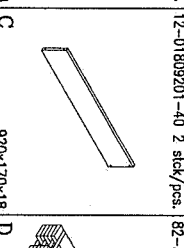
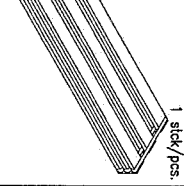
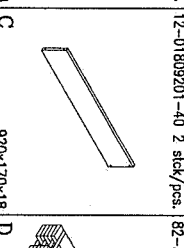
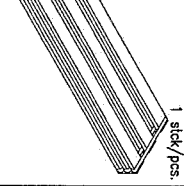

























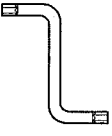
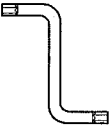
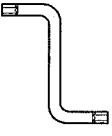
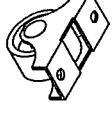
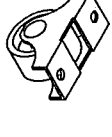
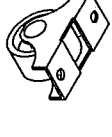



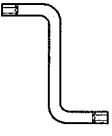
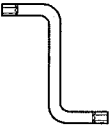
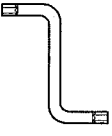
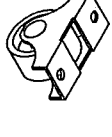
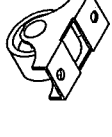
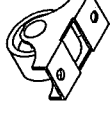

# 82-20045-40



	Before assembling this product, please ensure all the components supplied comply with the list on this page. All Screw-type fittings can be tightened with this tool:	Avant de commencer l'assemblage, veuillez vérifier si tous les objets inclus sur cette page sont les mêmes que ceux présentés sur cette page.	Bevor Sie mit dem Aufbau beginnen, kontrollieren Sie ob alle Teile richtig angepackt sind. Die schrauben sind Bitteschlüssel verwenden Sie zur Montage eines Kreuzschraubenzieher und den beiliegenden Innensechskantschlüssel.	Ware-nr. Part. no. Réf. No.	Stück. Qty. Qté.
1331-19001-40	 4mm				1
1331-19602-40					2
1900x170x18					1
1960x170x18					1
920x170x18					1

3908-70050	8	stick/pcs.	3902-35016	8	stick/pcs.	3901-40030	30	stick/pcs.	3901-40040	2	stick/pcs.
											
Z1	4	stick/pcs.	3912-04022	4	stick/pcs.	3928-000051	4	stick/pcs.	3940-00012	2	stick/pcs.
											
Z5	4x22	mm.	Z6	M5/6/10x1	mm.	Z7	ø18/ø4,5x12	mm.			
4033-004	1	stick/pcs.	4033-042	4	stick/pcs.	4001-010					
											
Z8	ø4	mm.	Z9			Z10	128	mm.			
											

## (GB): MAINTENANCE INSTRUCTIONS:

Check and bolts should from time to time be retightened.  
**CLEANING:** Wipe with a clean cloth or mild soap.  
**LACQUERED:** Waxed, lacquered and painted as well as laminated surfaces should be wiped over with a cloth and a mild soap.  
**OIL:** Oiled surfaces can be cleaned with soapy water, e.g. brown soap.  
 Wipe with a clean cloth.  
 To maintain the natural life in the furniture which is provided by the oil treatment, we recommend an oil aftercare of the furniture 1-2 times a year. The colours natural oil for maintenance of oil-treated furniture is available at your local furniture store.

## (D): FLEGEHINWEIS:

Schrauben und Bolzen sollten regelmäßig nachgezogen werden.  
**REINIGUNG:** Wischen Sie mit einem sauberen Leinwand- oder Baumwolltuch ab.  
**GEÖLT:** Geölte Holzoberflächen können mit einem sauberen Lappen und Seifenwasser, z.B. Seifenwasser, gereinigt werden. Um das natürliche Aussehen des Holzes zu bewahren, ist eine Öl-Nachbehandlung vom Möbelfabrikant empfohlen. Das farblose Öl für die Nachbehandlung der Möbel, kann in Ihrem Möbelfachgeschäft gekauft werden.

## (F): CONSEILS D'ENTRETIEN:

Votre lit doit être périodiquement vérifié de reserrer les vis.  
**NETTOYAGE:** Nettoyez les surfaces en bois, laquées, peintes et laminées avec une éponge ou un chiffon et un savon doux.  
**HUILE:** Les surfaces de bois naturel peuvent être entretenues avec de l'huile naturelle.  
 par ex. savon de Marseille, et essayés avec un chiffon propre de tricotier, maintenez l'aspect naturel du bois, nous vous recommandons de traiter avec une huile d'entretien 1-2 fois par an. L'huile naturelle sans colorant peut être achetée dans votre magasin de meubles.

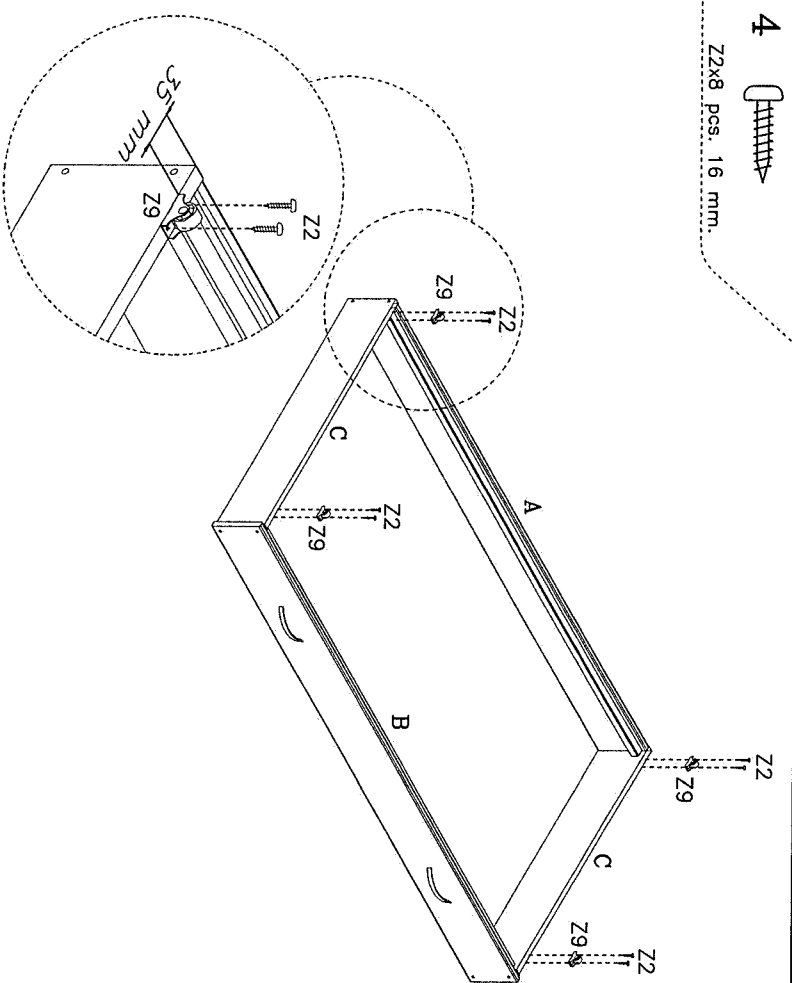
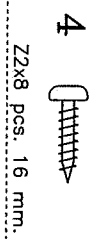
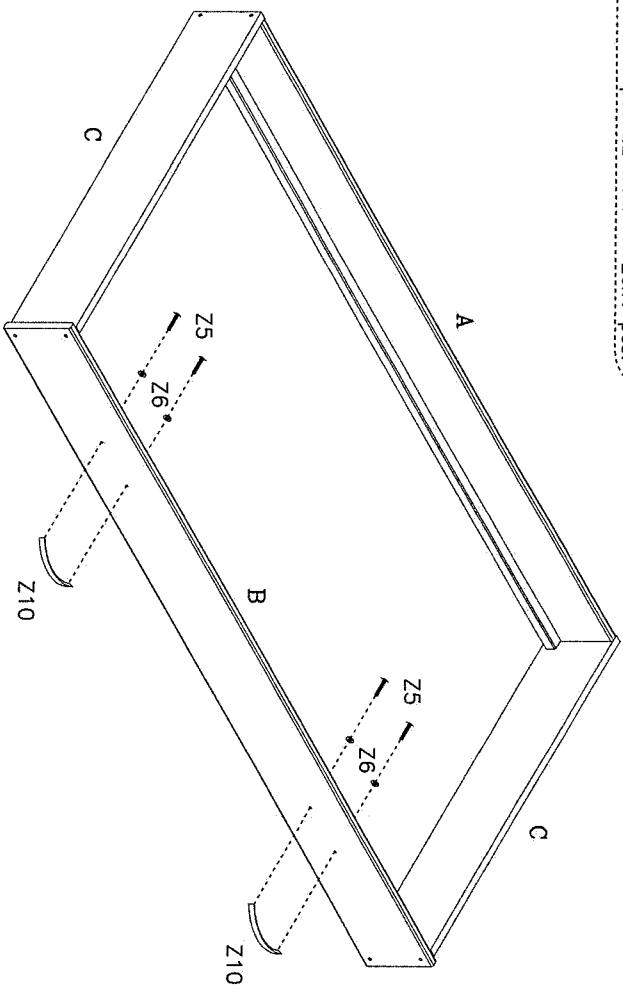
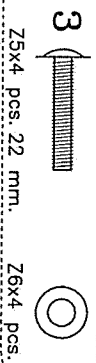
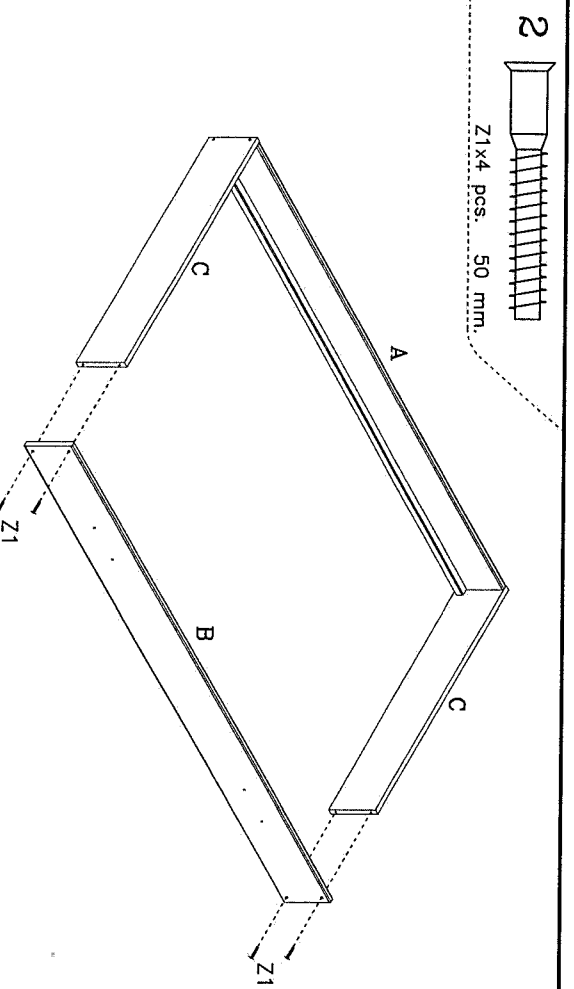
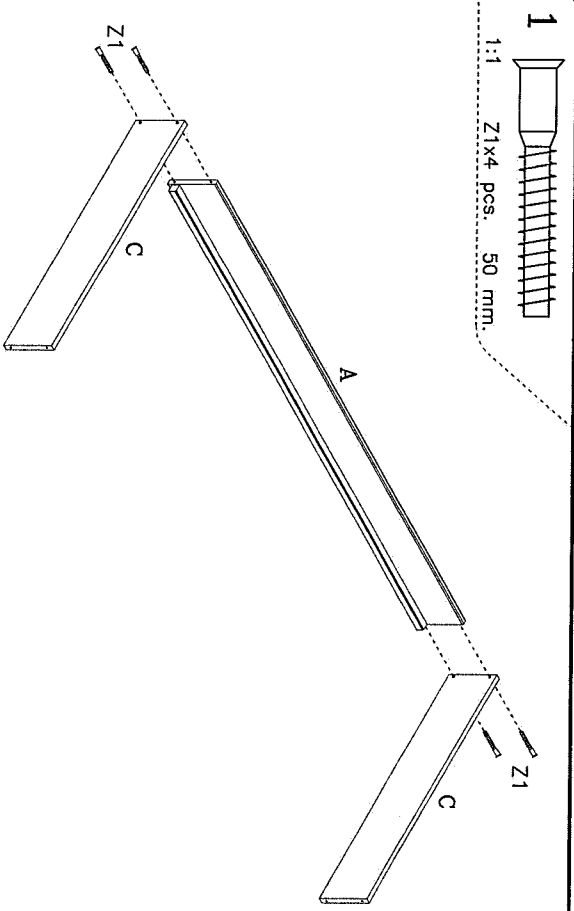

5



Z4x2 pcs. 40 mm.

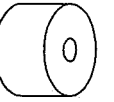

Z7x2 pcs.

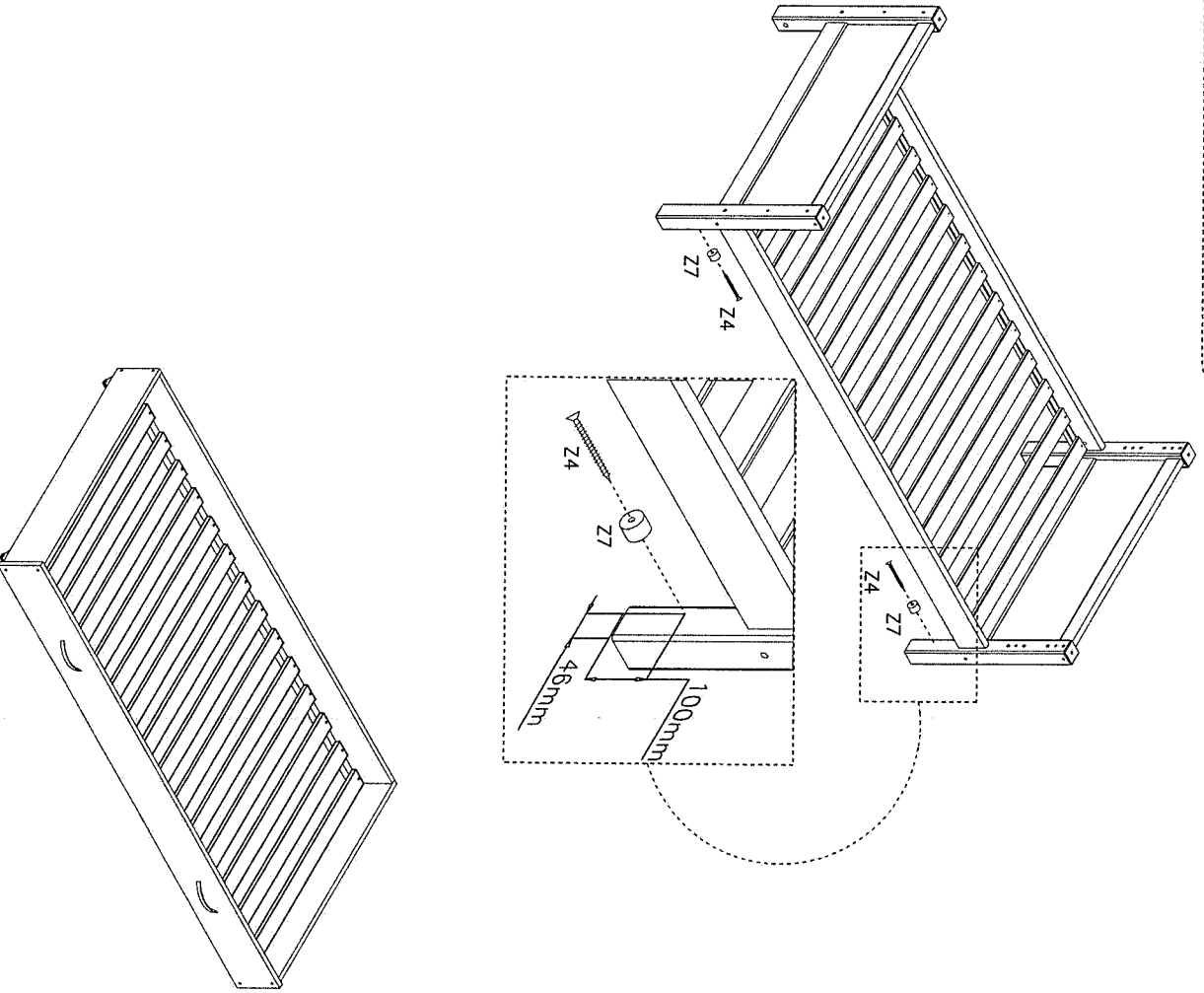

6



Z3x30 pcs. 30 mm.

