

FLORENZ 23M

OPTION L

OPTION R

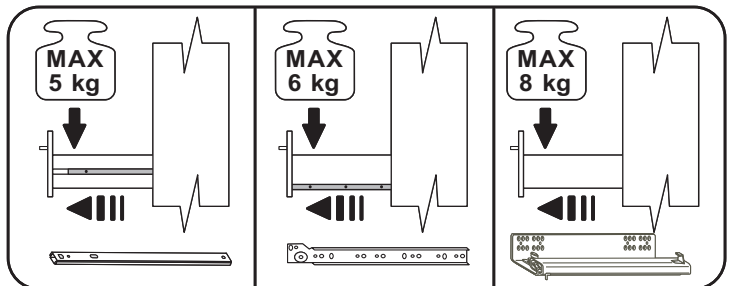
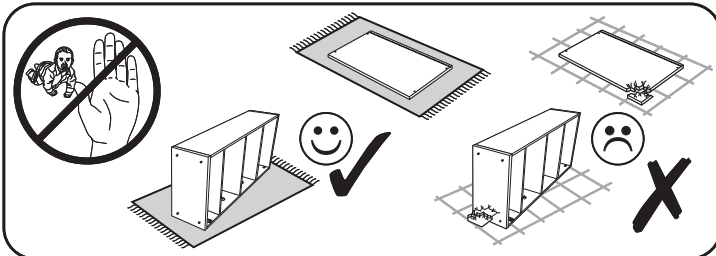
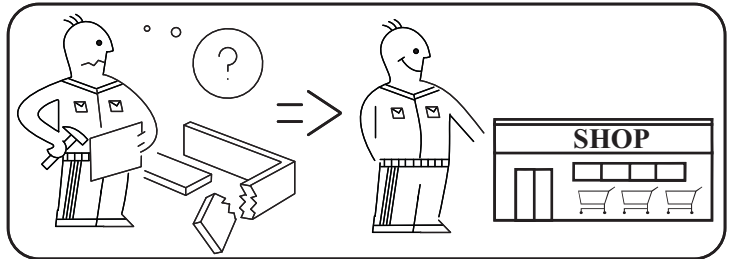
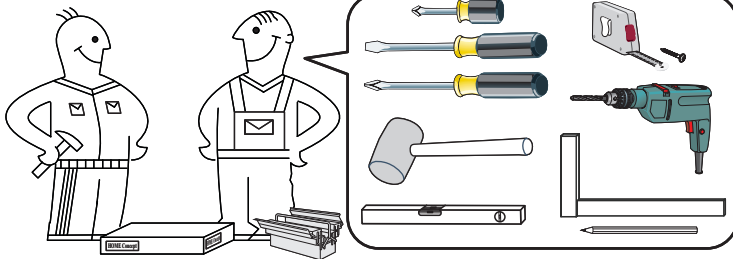
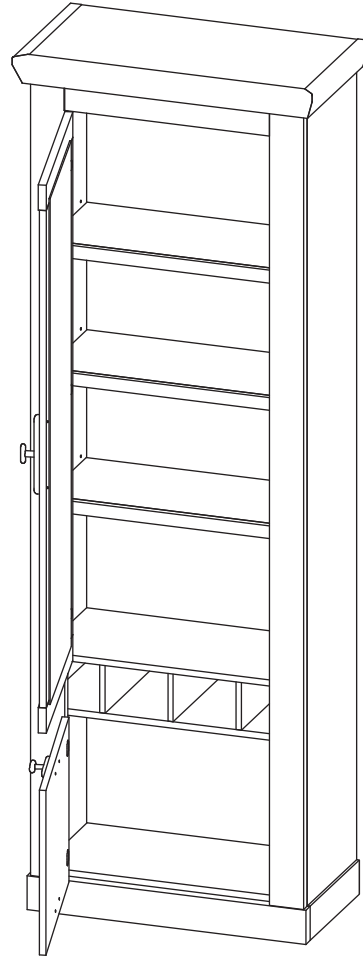
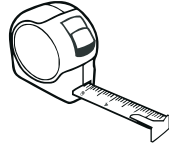
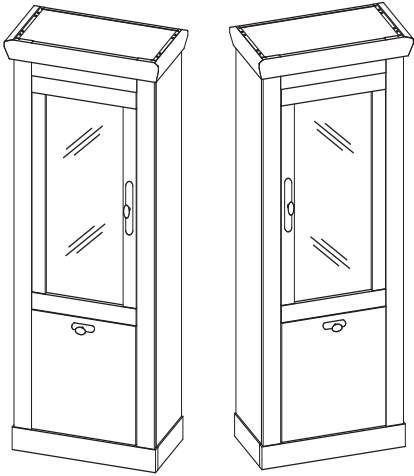

FLORENZ 23M

max. MHC15



5kg MHC12

max.



15kg MHC3

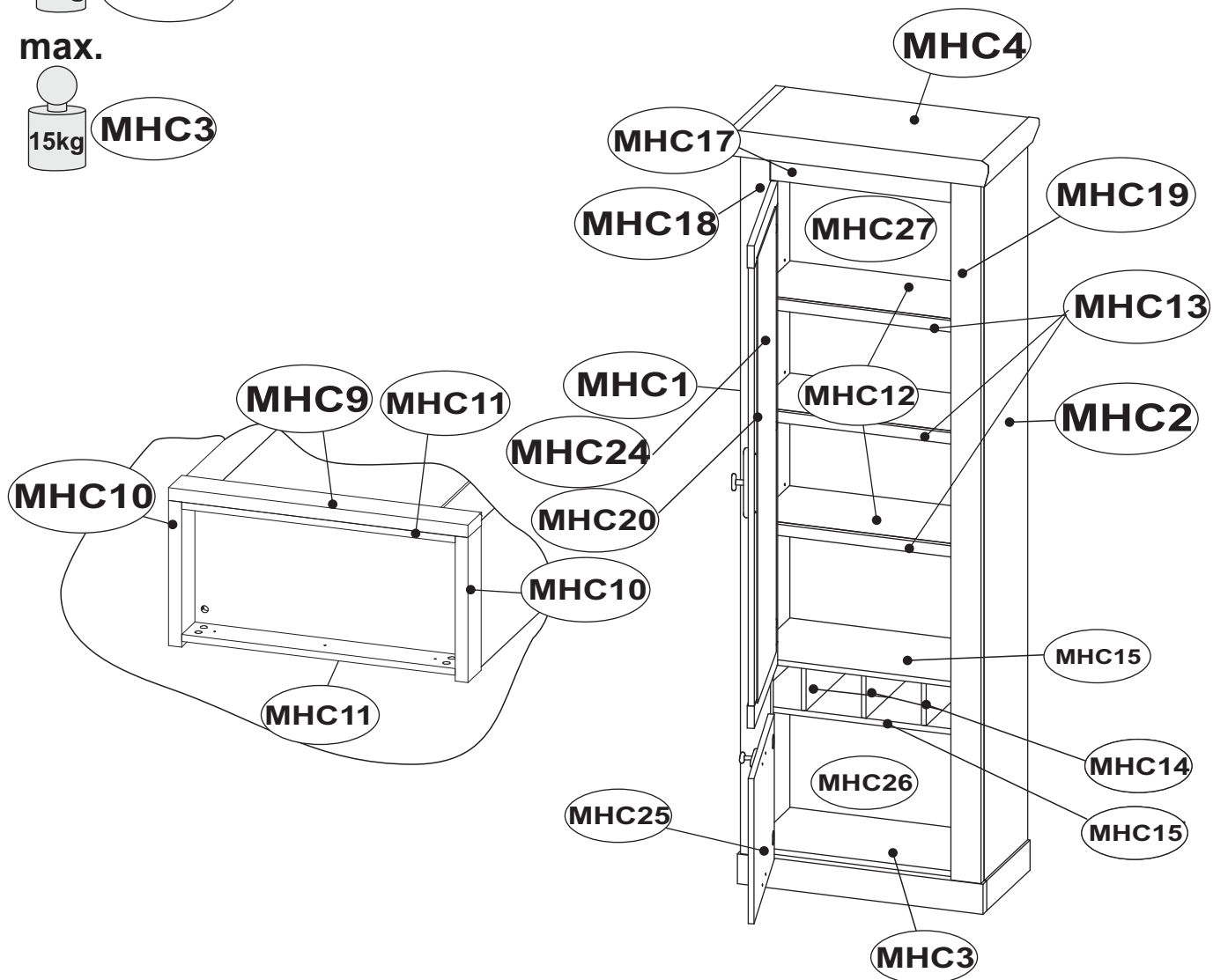

| | | | | |
|-------|------|-------|----|-----|
| MHC1 | 1911 | 320 | 15 | 2/2 |
| MHC2 | 1911 | 320 | 15 | 2/2 |
| MHC3 | 611 | 299 | 15 | 1/2 |
| MHC4 | 699 | 370,5 | 65 | 1/2 |
| MHC9 | 655 | 80 | 28 | 1/2 |
| MHC10 | 317 | 80 | 28 | 1/2 |
| MHC11 | 598 | 80 | 15 | 1/2 |
| MHC12 | 610 | 267 | 15 | 1/2 |
| MHC13 | 608 | 30 | 16 | 1/2 |
| MHC14 | 112 | 298 | 15 | 1/2 |
| MHC15 | 611 | 299 | 15 | 1/2 |

| | | | | |
|-------|------|-----|----|-----|
| MHC17 | 483 | 120 | 18 | 2/2 |
| MHC18 | 1911 | 80 | 22 | 2/2 |
| MHC19 | 1911 | 80 | 22 | 2/2 |
| MHC20 | 1279 | 477 | 18 | 2/2 |
| MHC24 | 1189 | 386 | 4 | 2/2 |
| MHC25 | 388 | 477 | 15 | 2/2 |
| MHC26 | 385 | 623 | 3 | 2/2 |
| MHC27 | 1531 | 623 | 3 | 2/2 |

FLORENZ 23M

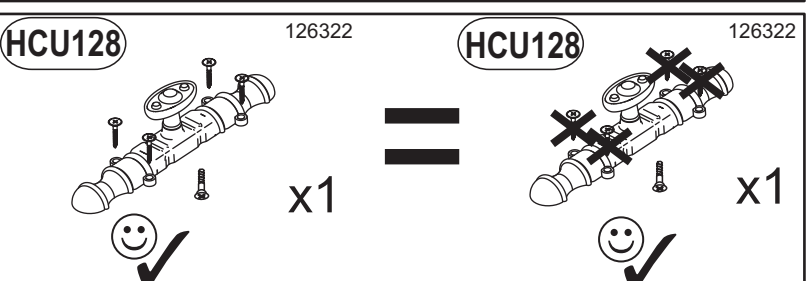
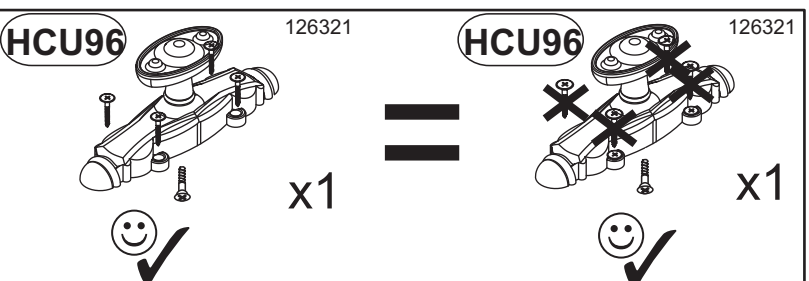
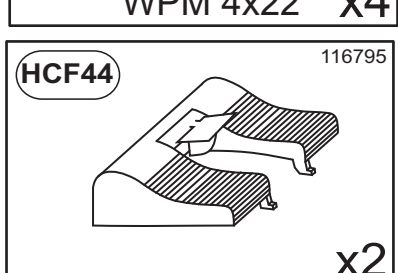
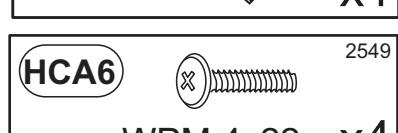
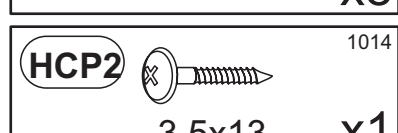
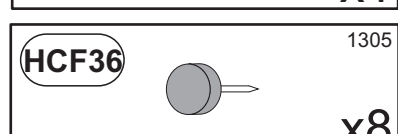
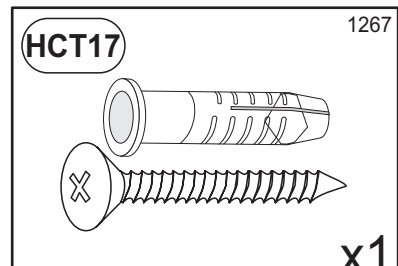
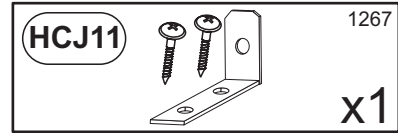
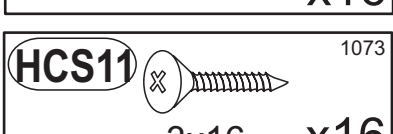
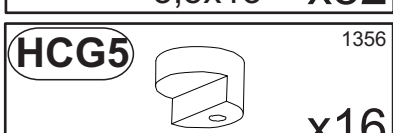
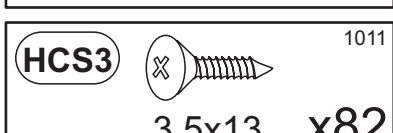
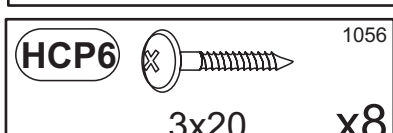
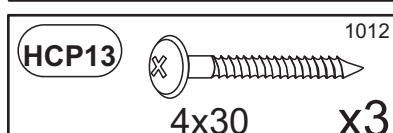
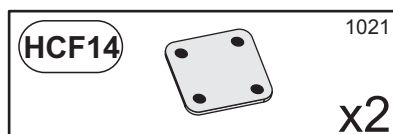
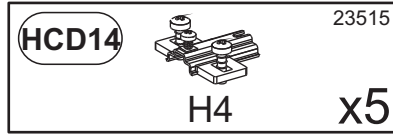
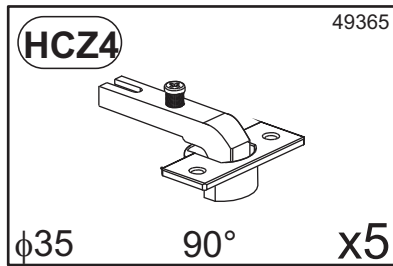
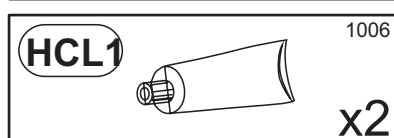
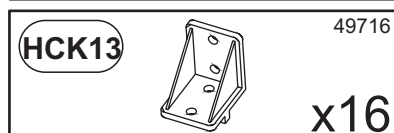
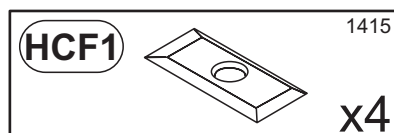
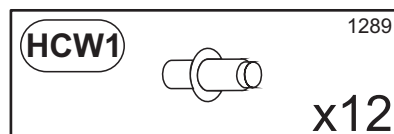
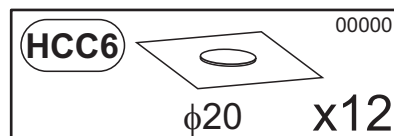
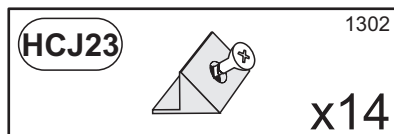
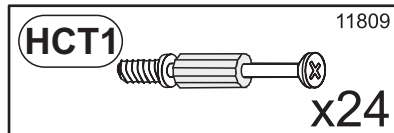
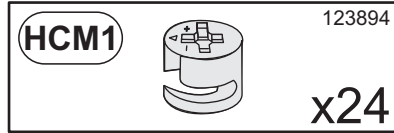
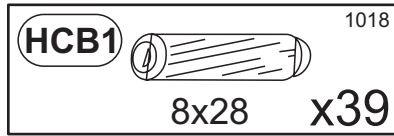

1

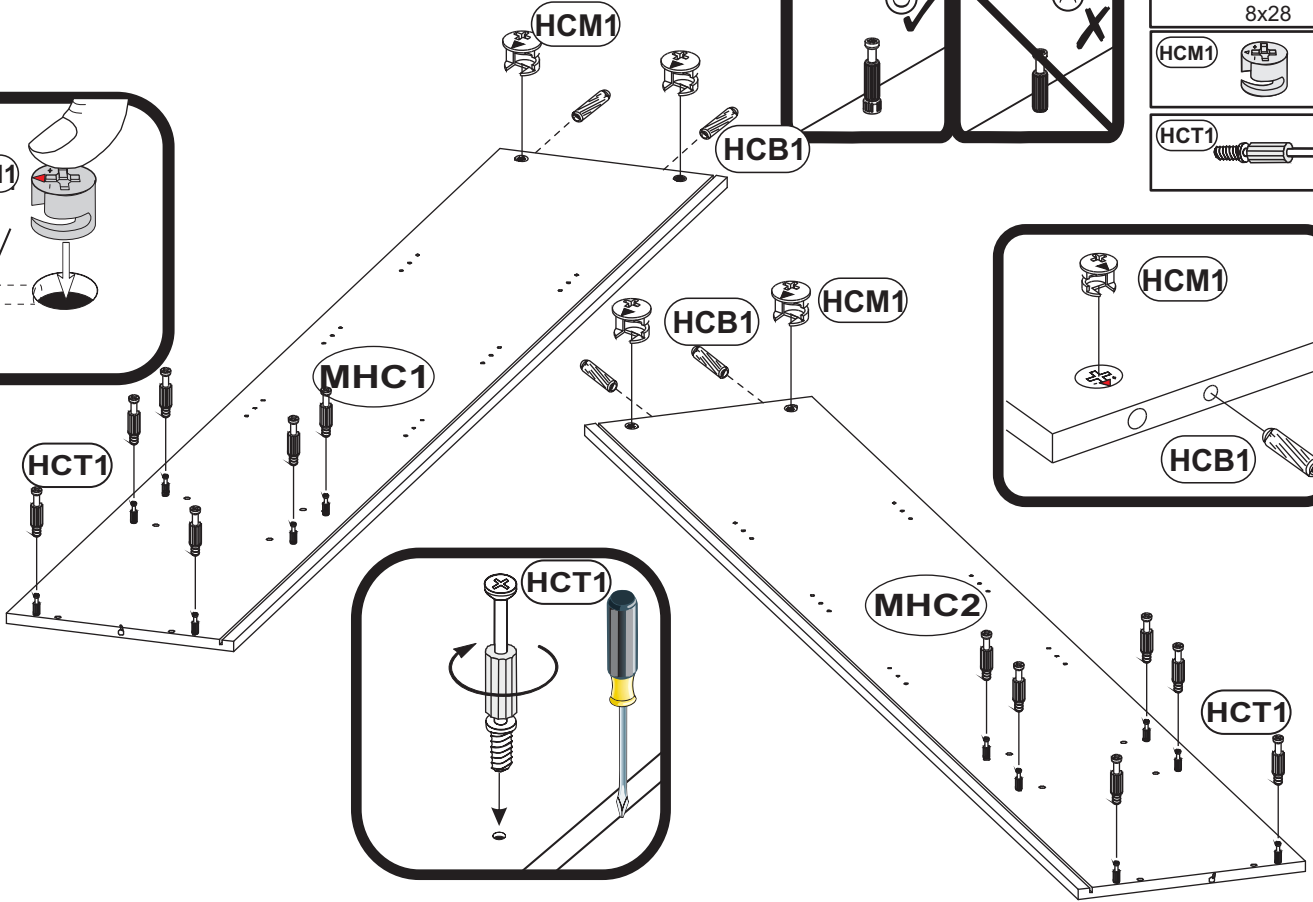
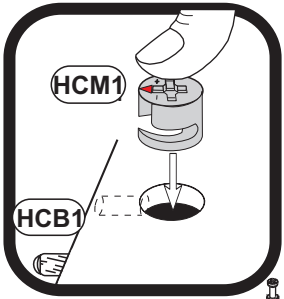

| | | |
|------|------|--------|
| HCB1 | | 1018 |
| | 8x28 | x4 |
| HCM1 | | 123894 |
| | | x4 |
| HCT1 | | 11809 |
| | | x12 |

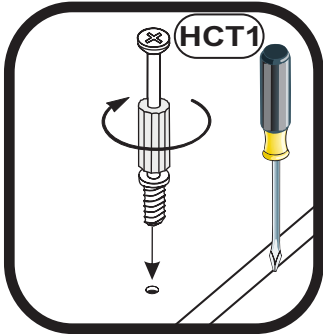
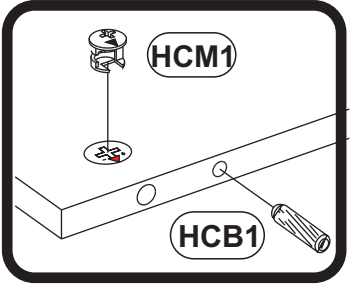

2

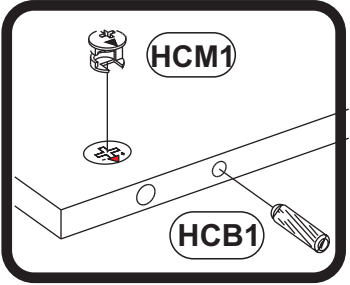
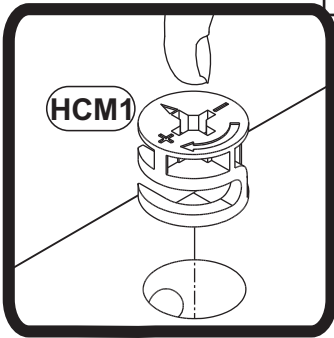
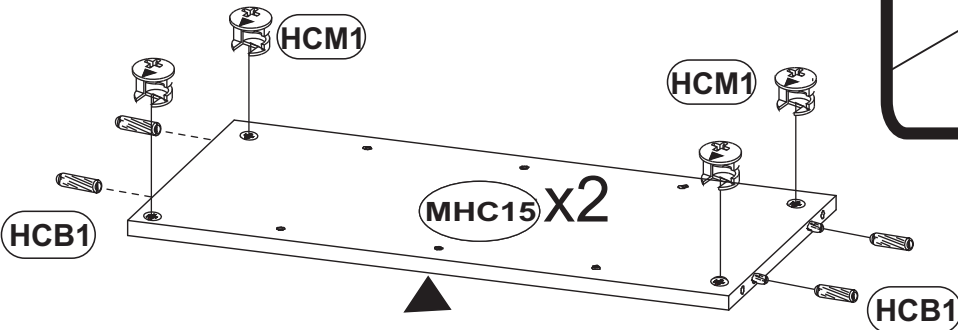

| | | |
|------|------|--------|
| HCM1 | | 123894 |
| | | x8 |
| HCB1 | | 1018 |
| | 8x28 | x8 |

3

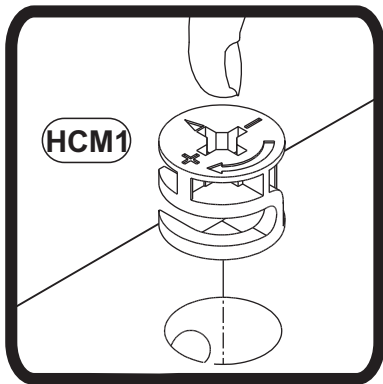

HCS3 1011
3,5x13 x4

HCM1 1336
x4

HCB1 1018
8x28 x16

HCF14 1021
x2

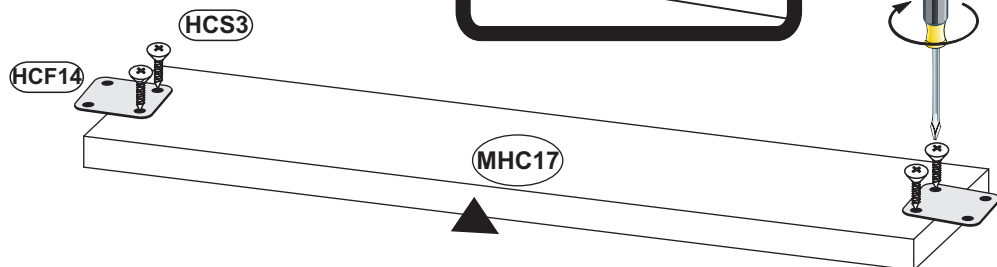
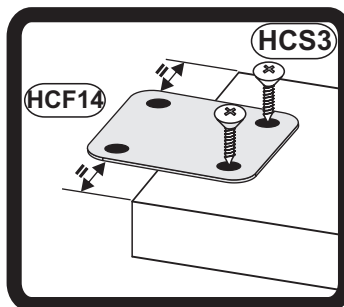
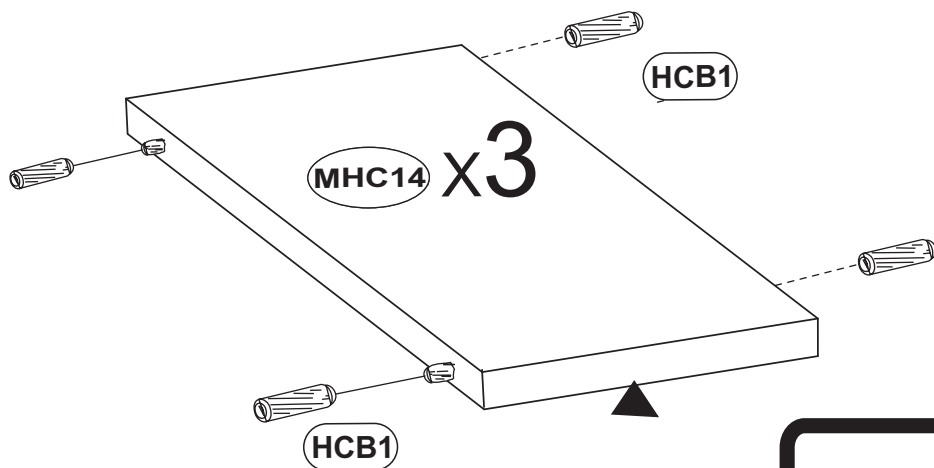
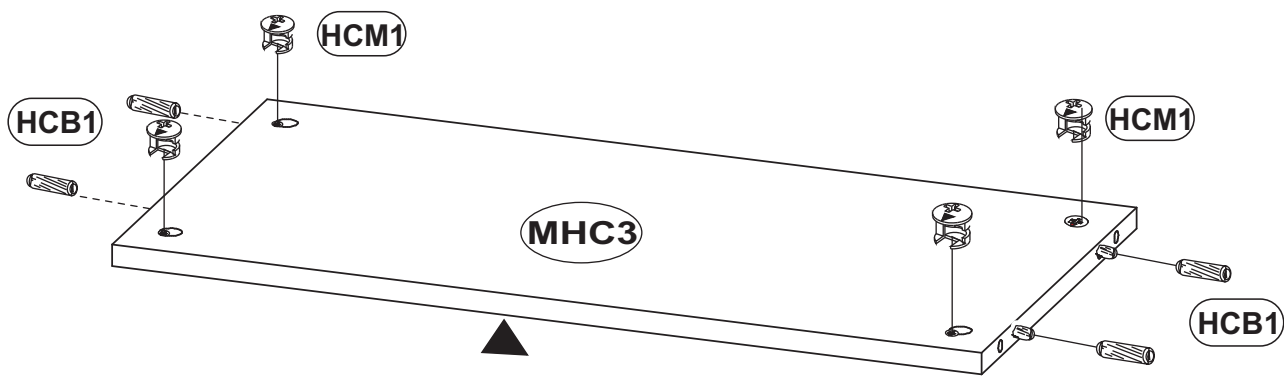
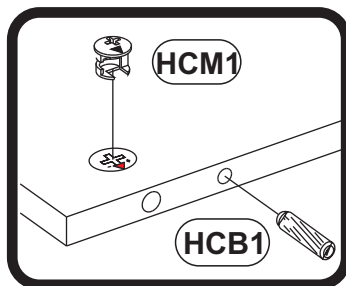

4

OPTION L

OPTION L

| | | | |
|-------|--|-------|------------|
| HCK13 | | 49716 | x12 |
| HCD14 | | 23515 | x5 |
| HCS3 | | 1011 | 3,5x13 x24 |

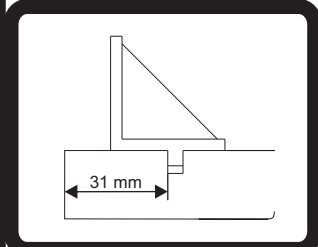
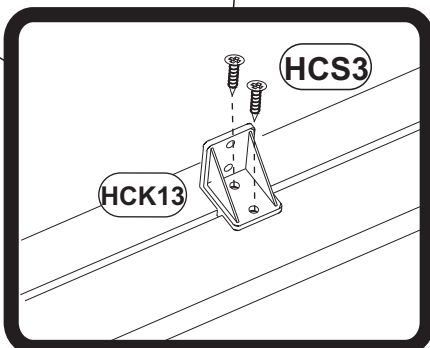
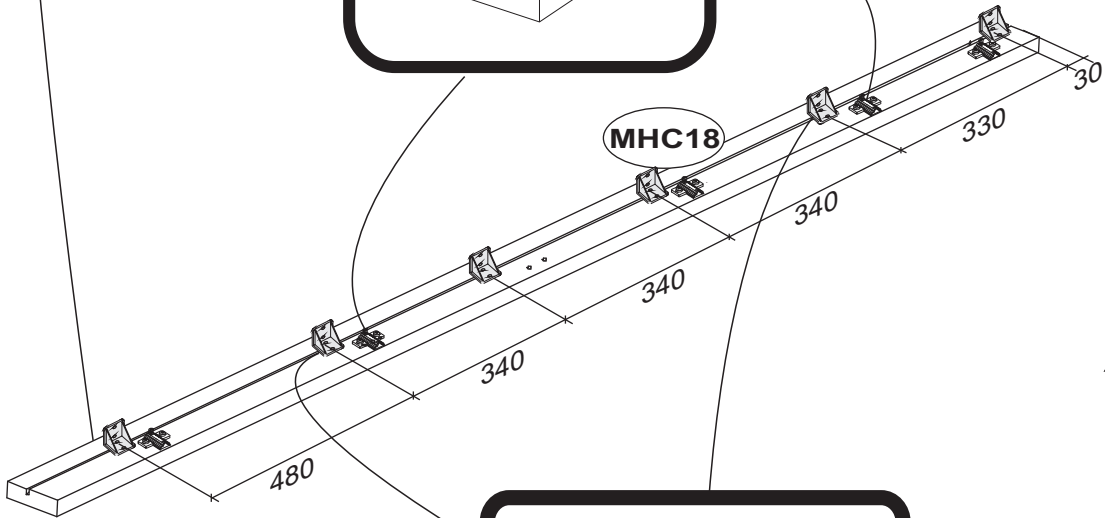
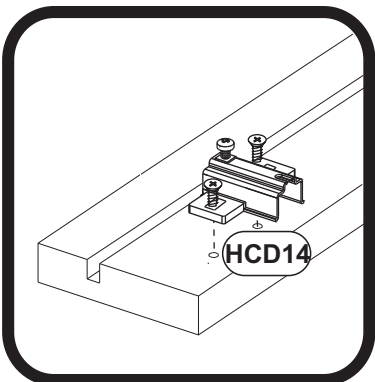
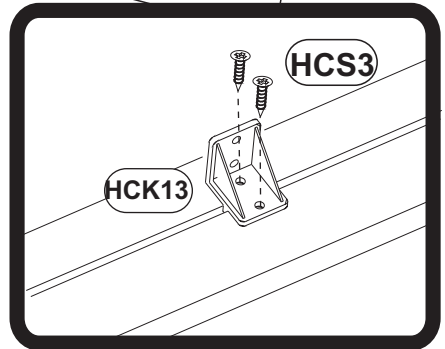
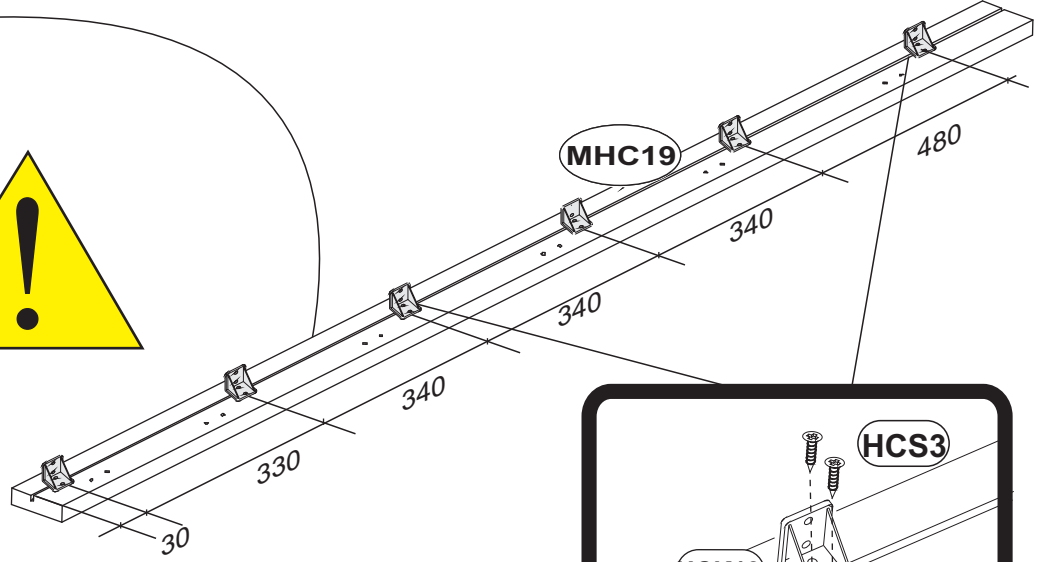
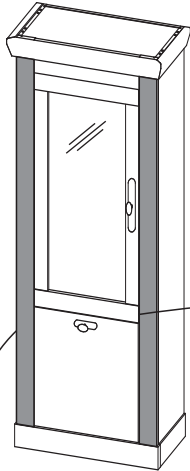
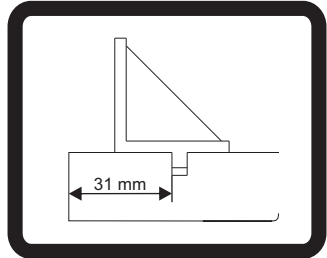

5

OPTION R

OPTION R



| | | | |
|-------|--|-------|------------|
| HCK13 | | 49716 | x12 |
| HCD14 | | 23515 | x5 |
| HCS3 | | 1011 | 3,5x13 x24 |

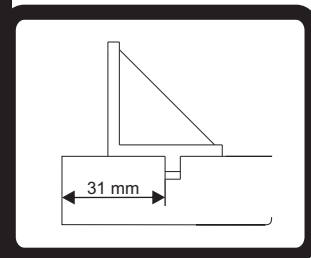
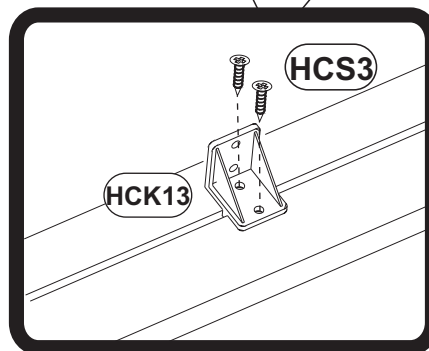
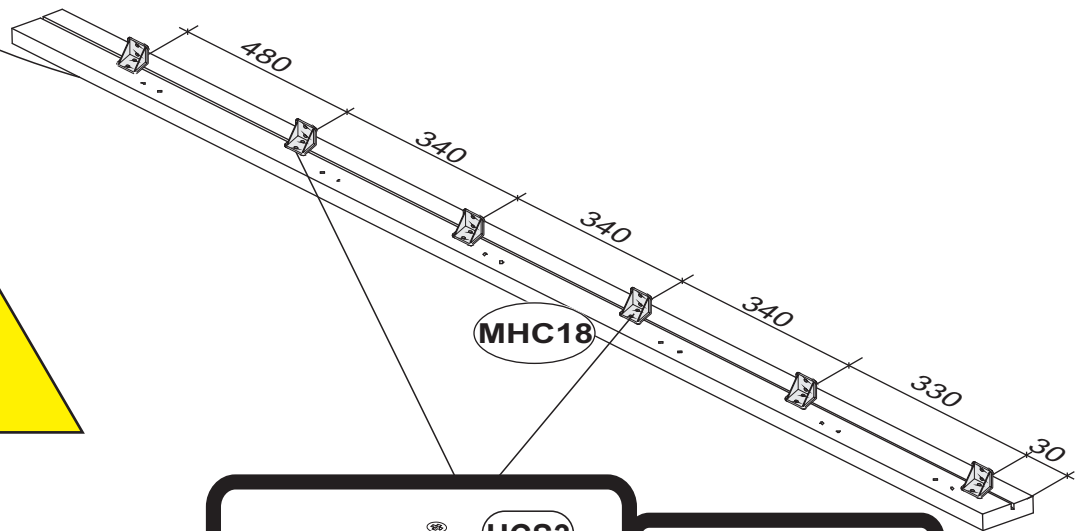
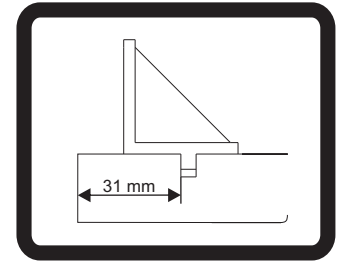
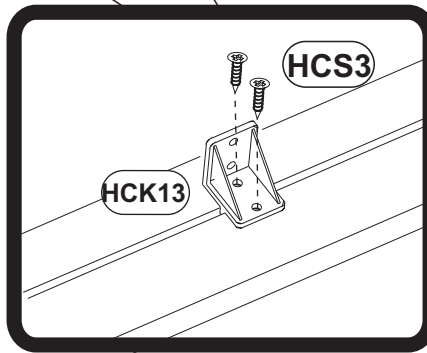
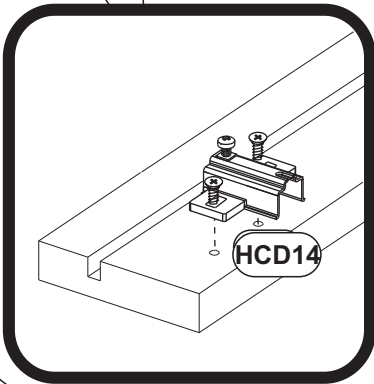
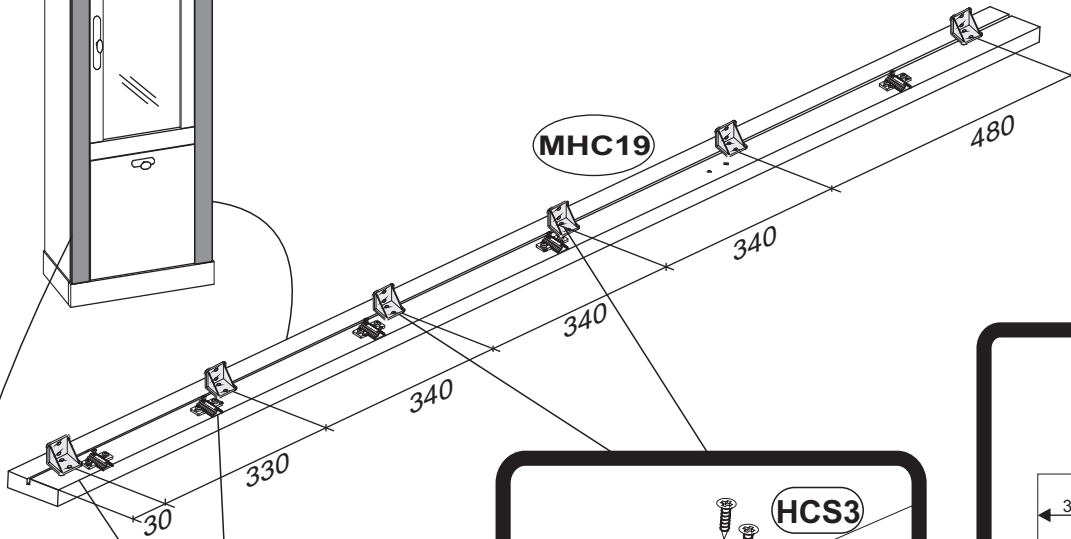
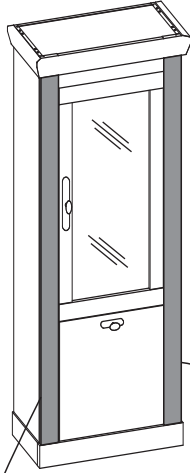

6

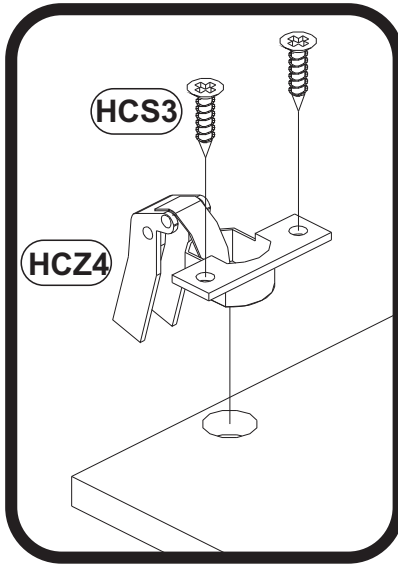
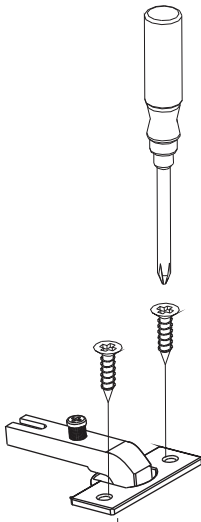
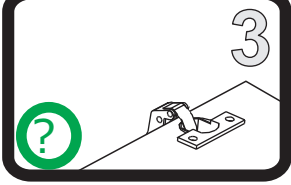
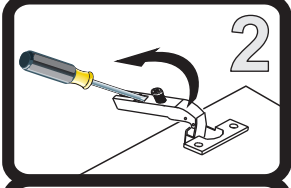
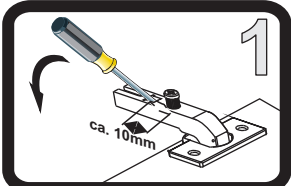
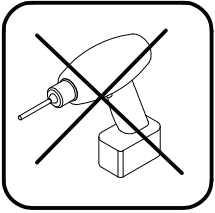

- HCZ4** 49365
φ35 90° x5
- HCS3** 1011
3,5x13 x10
- HCF44** 116795
x2
- HCG5** 1356
x16
- HCS11** 1073
3x16 x16

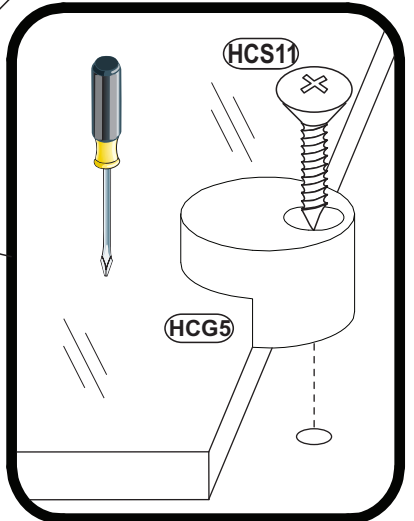
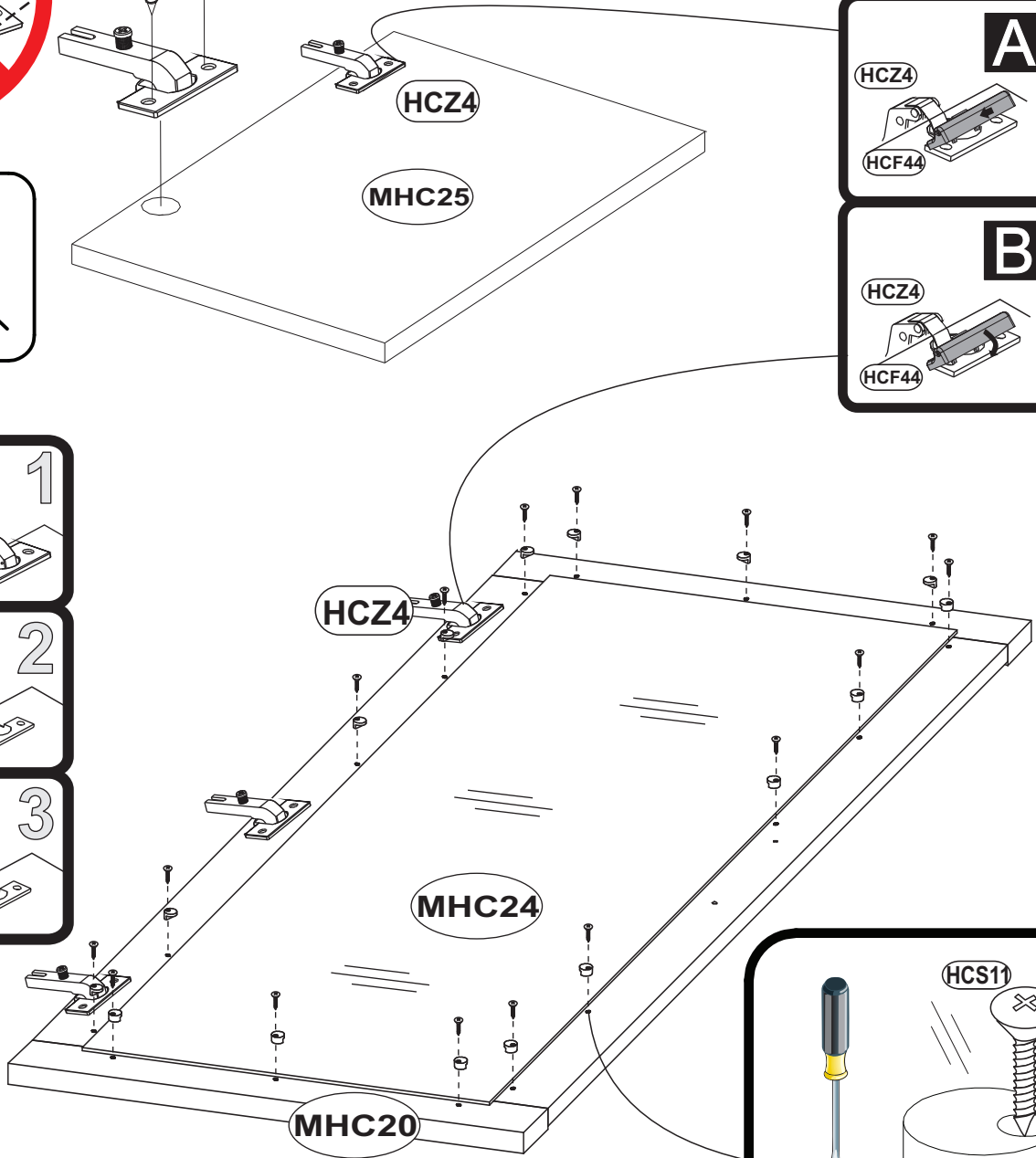
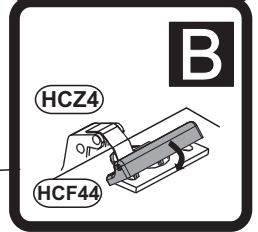
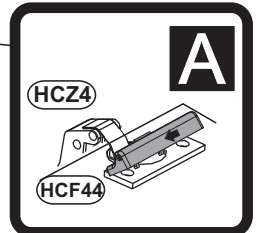

7

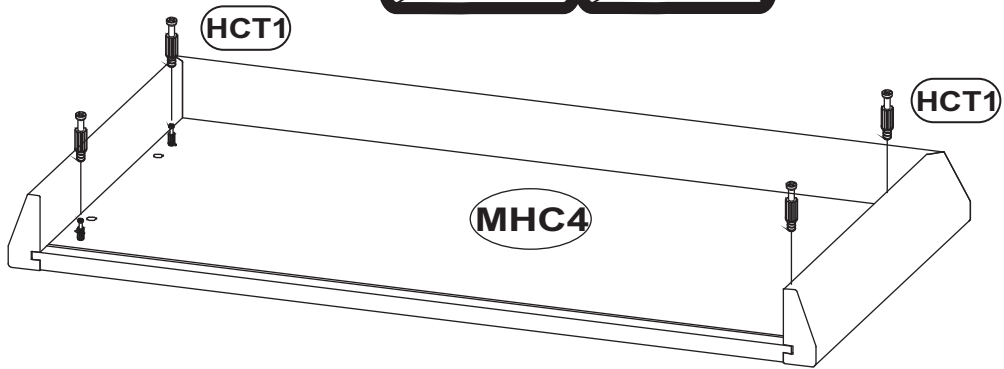
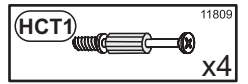
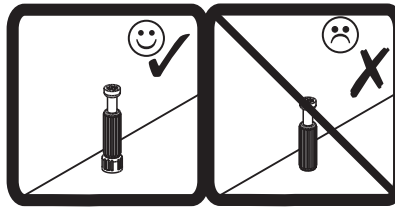

8

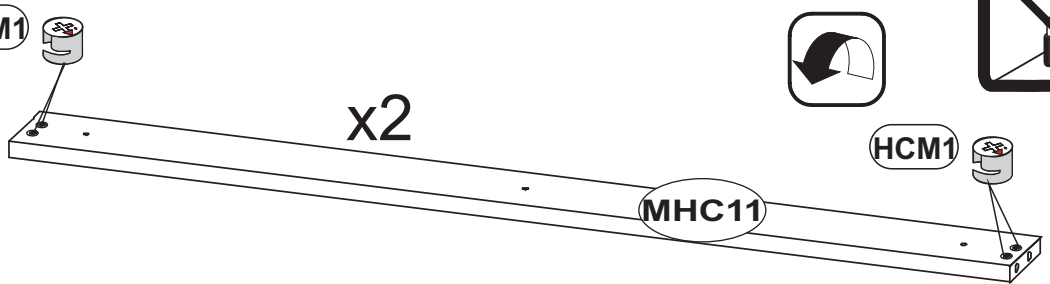
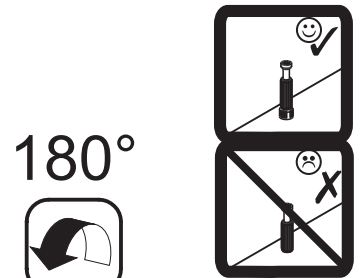
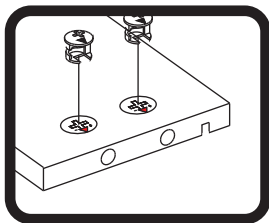
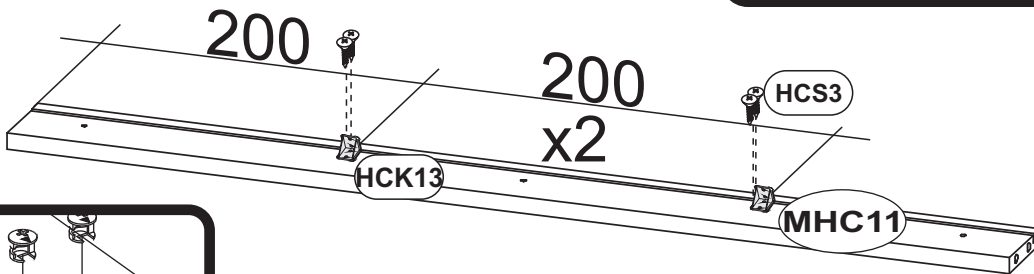
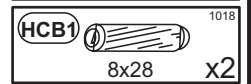
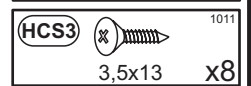
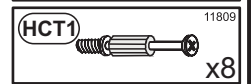
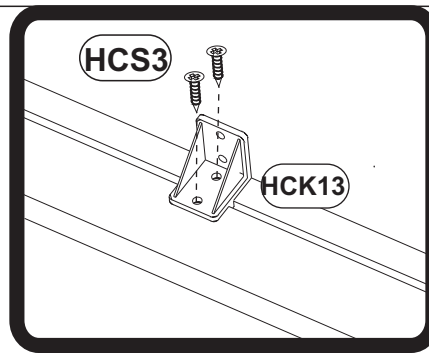
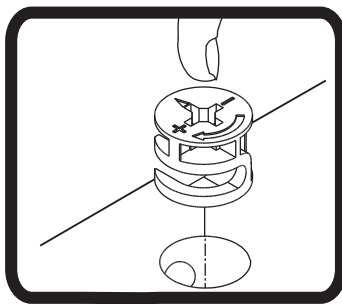

HCT1

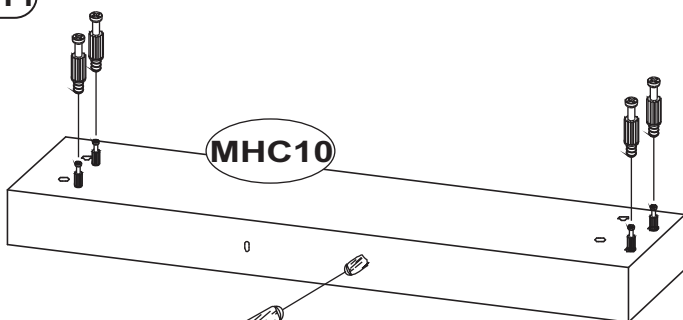

HCT1

HCT1

HCT1

MHC10

HCB1

9

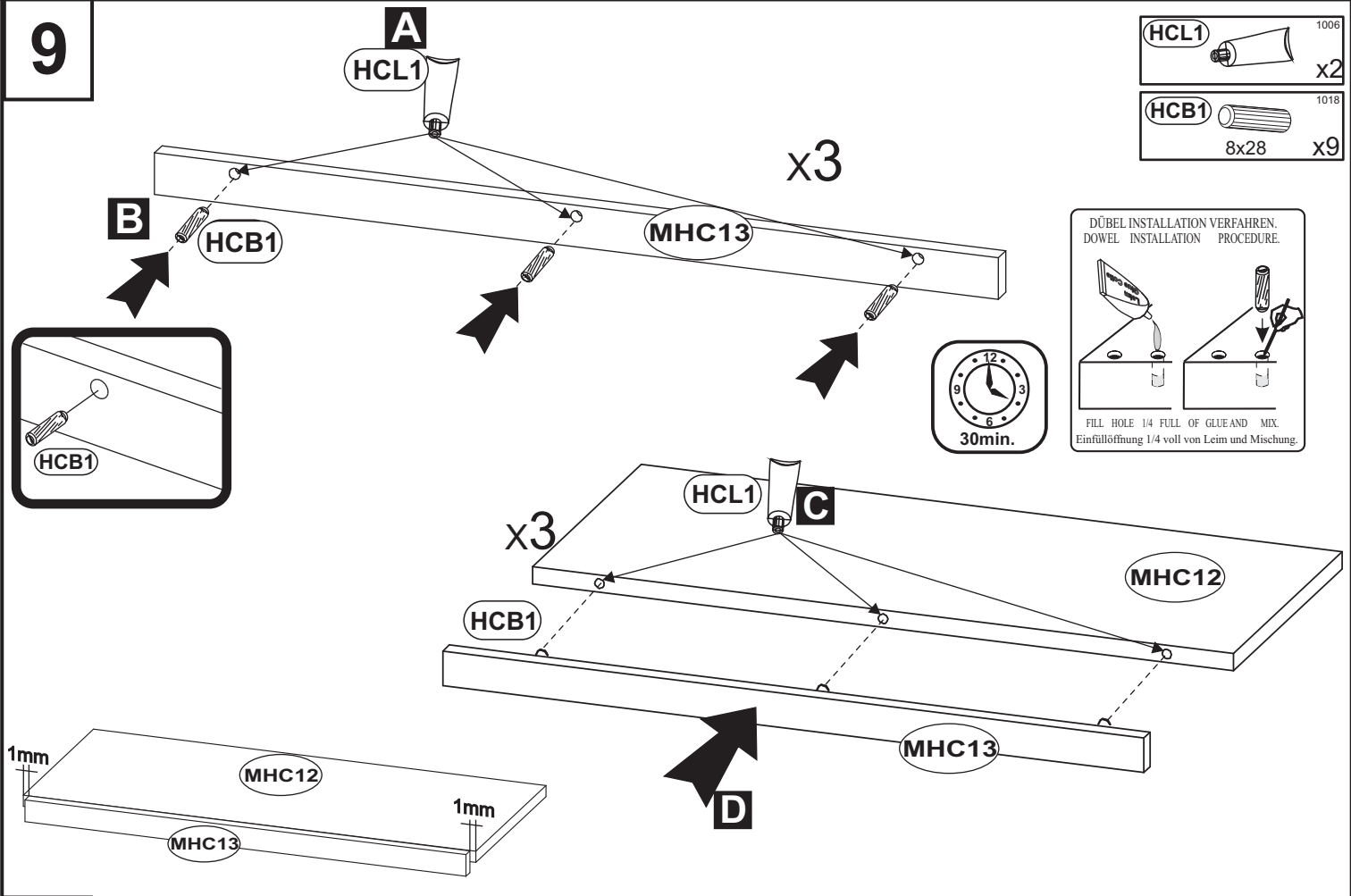

10

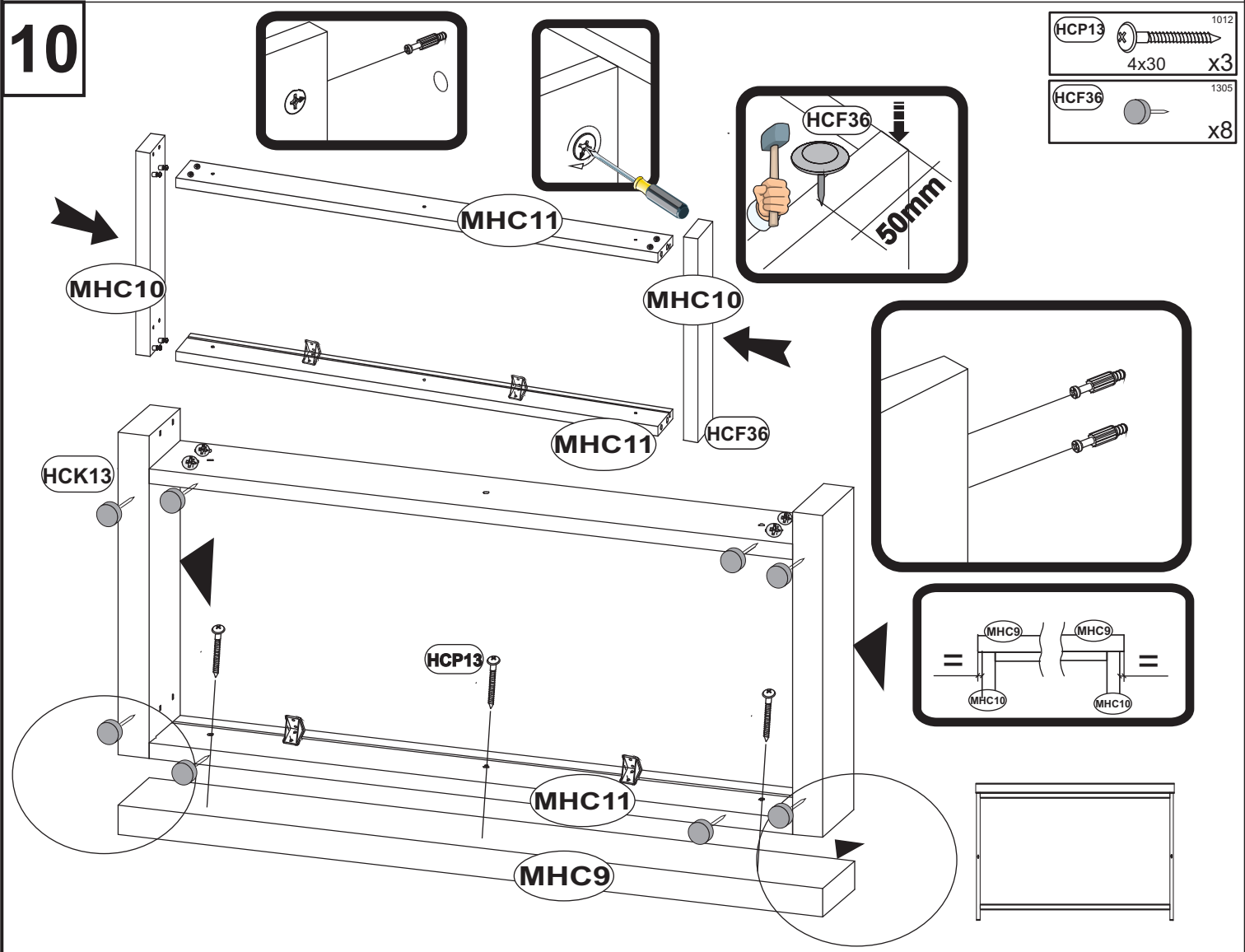

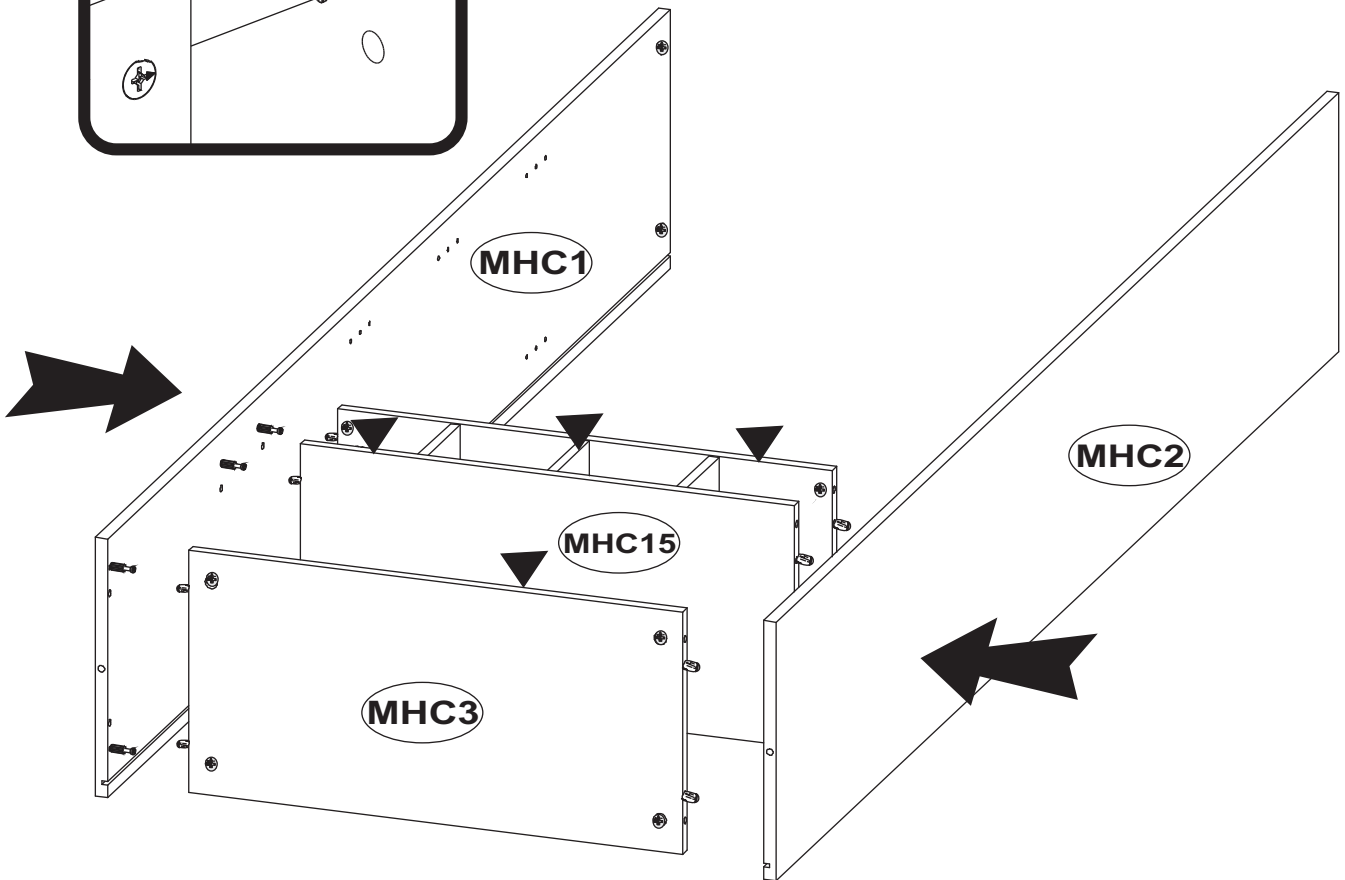
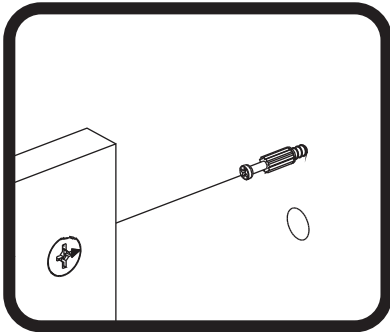
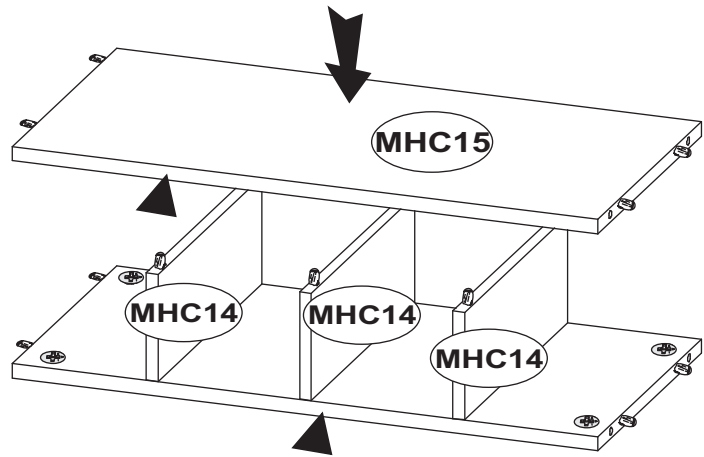
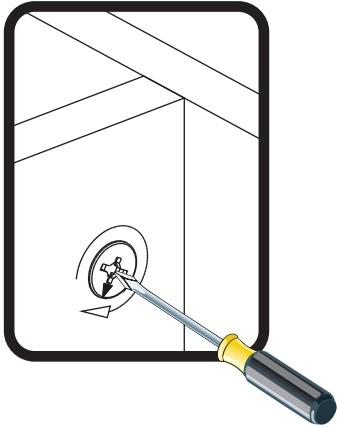
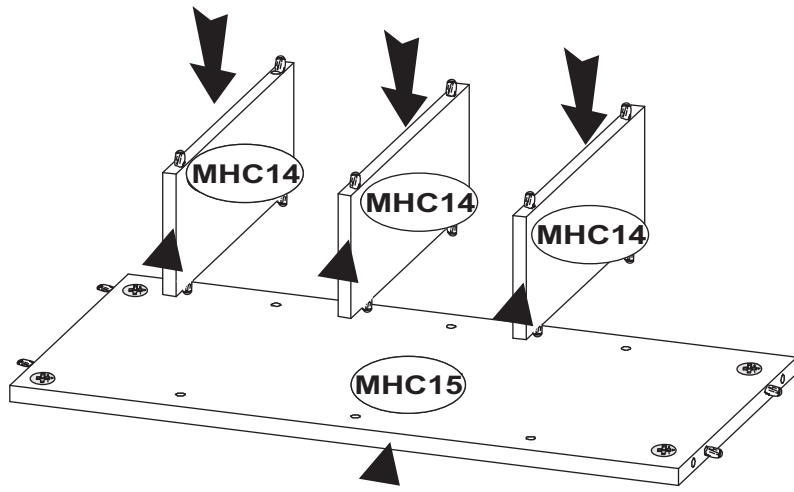



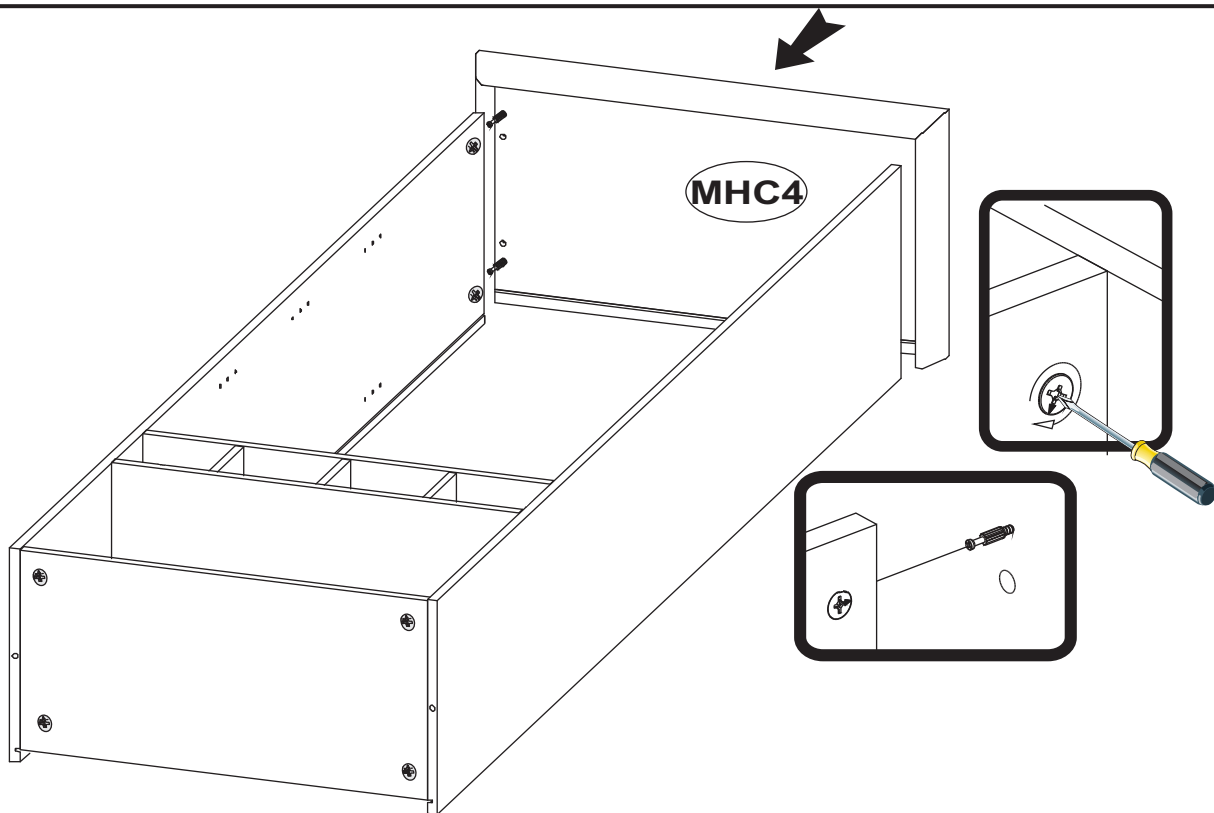

12

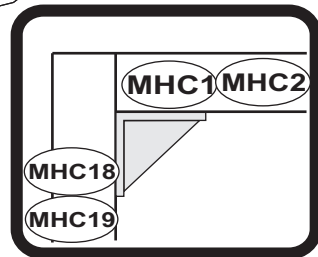
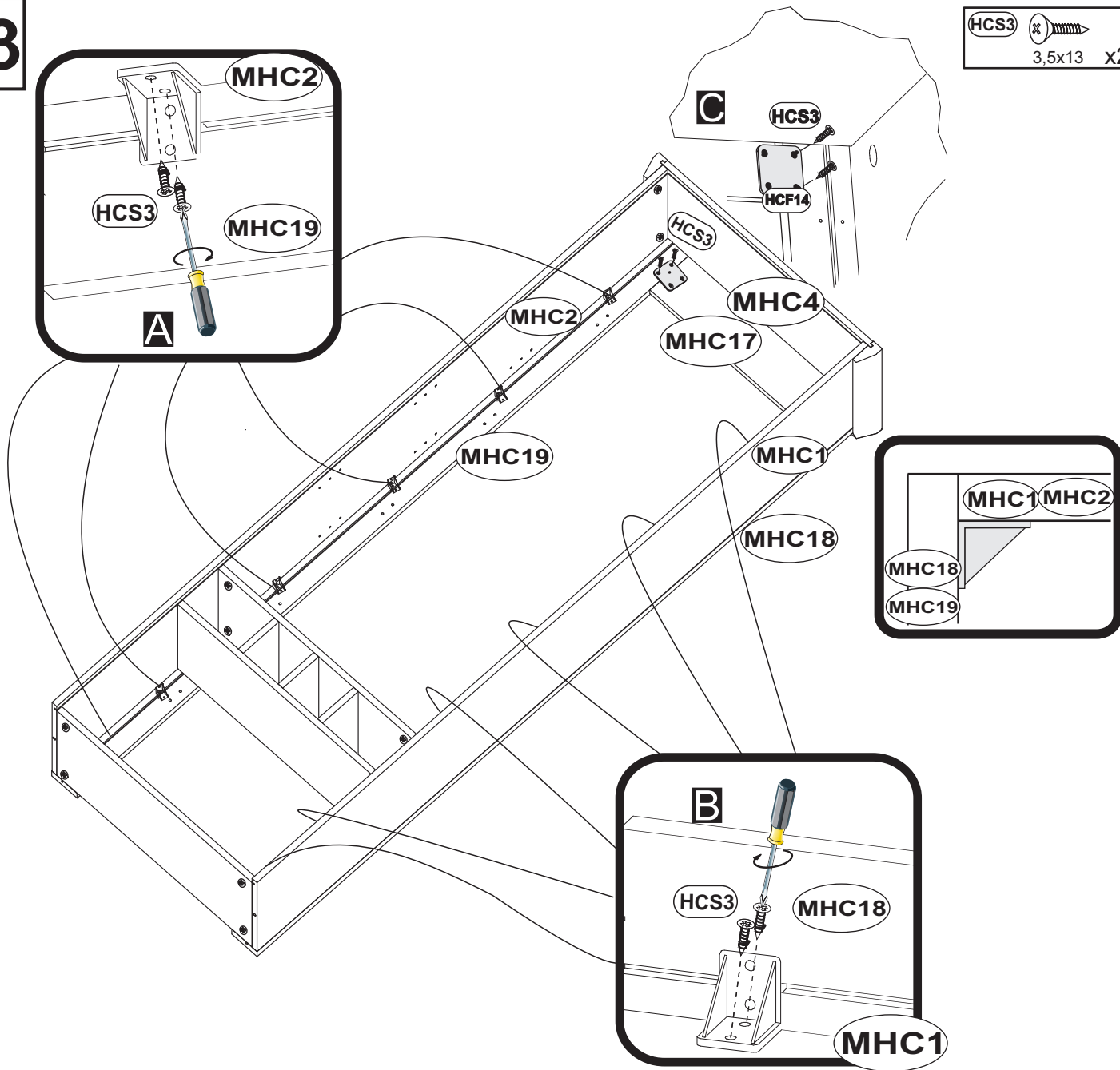
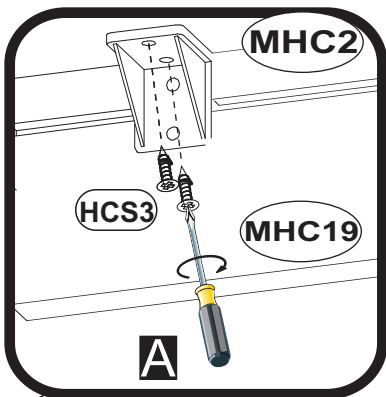

13

HCS3  1011
3,5x13 x28



| | | |
|-------|---|------|
| HCJ23 |  | 1302 |
| | | x14 |
| HCF1 |  | 1415 |
| | | x4 |
| HCP6 |  | 1056 |
| | 3x20 | x8 |

B

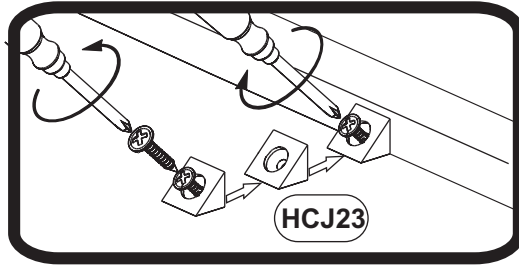

A

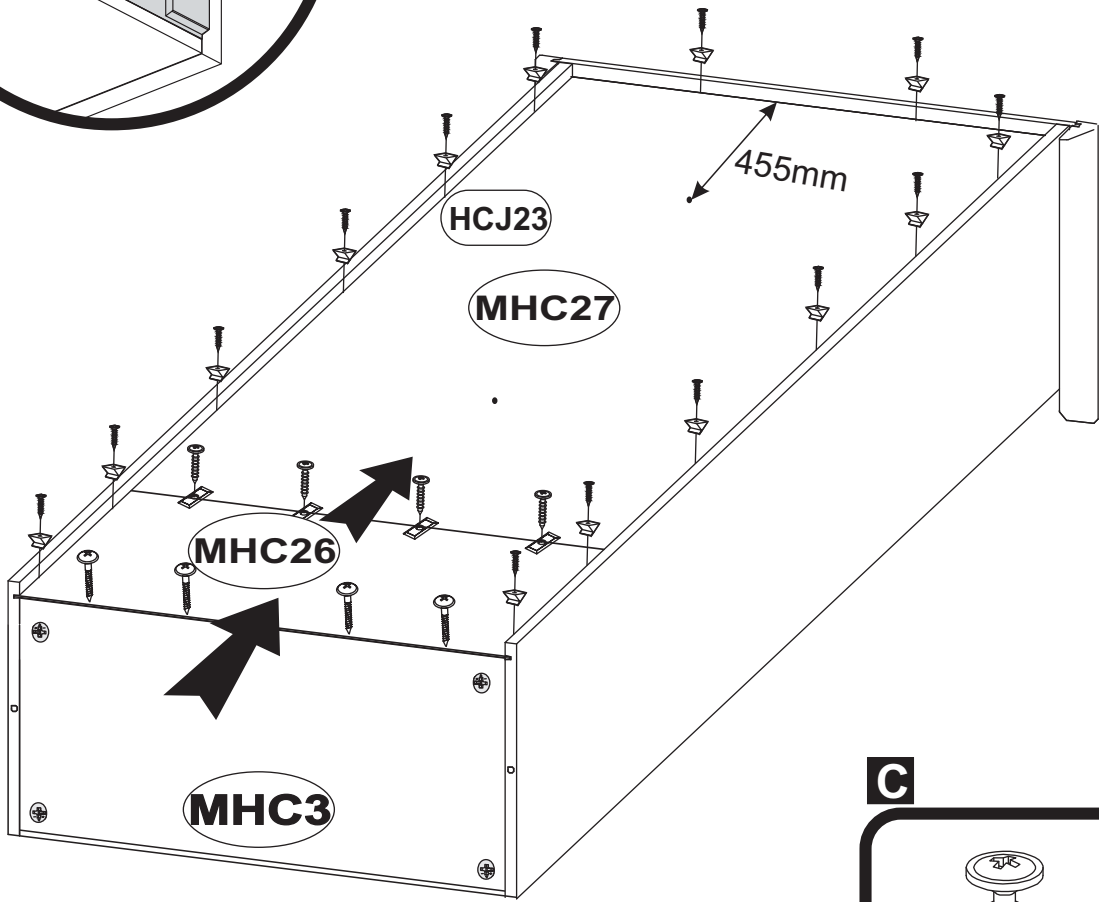
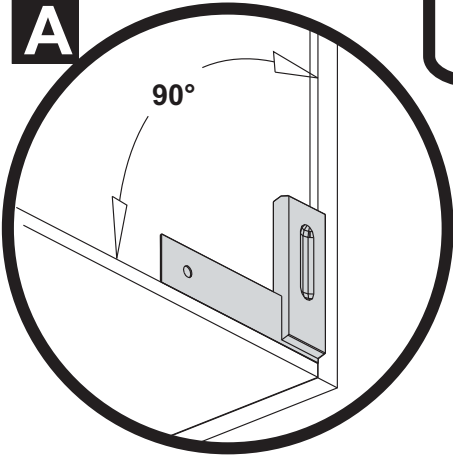

C

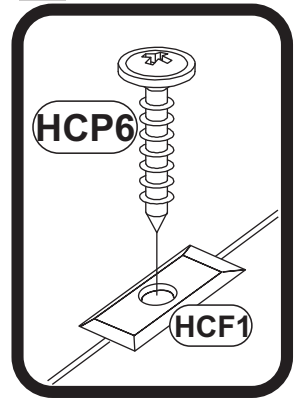

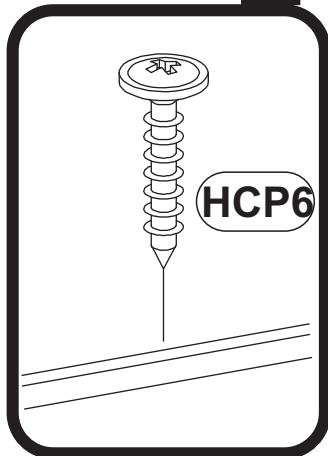

D

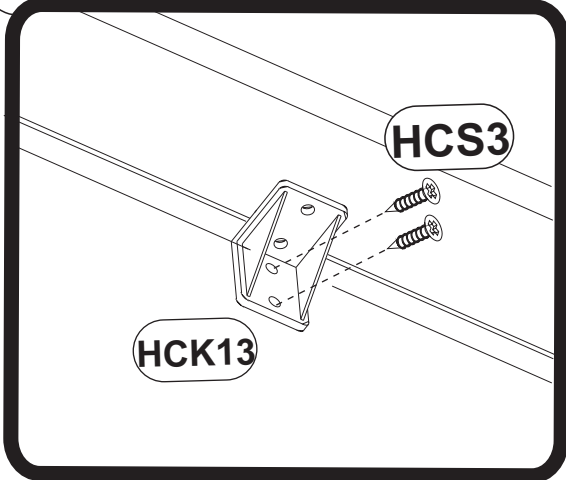
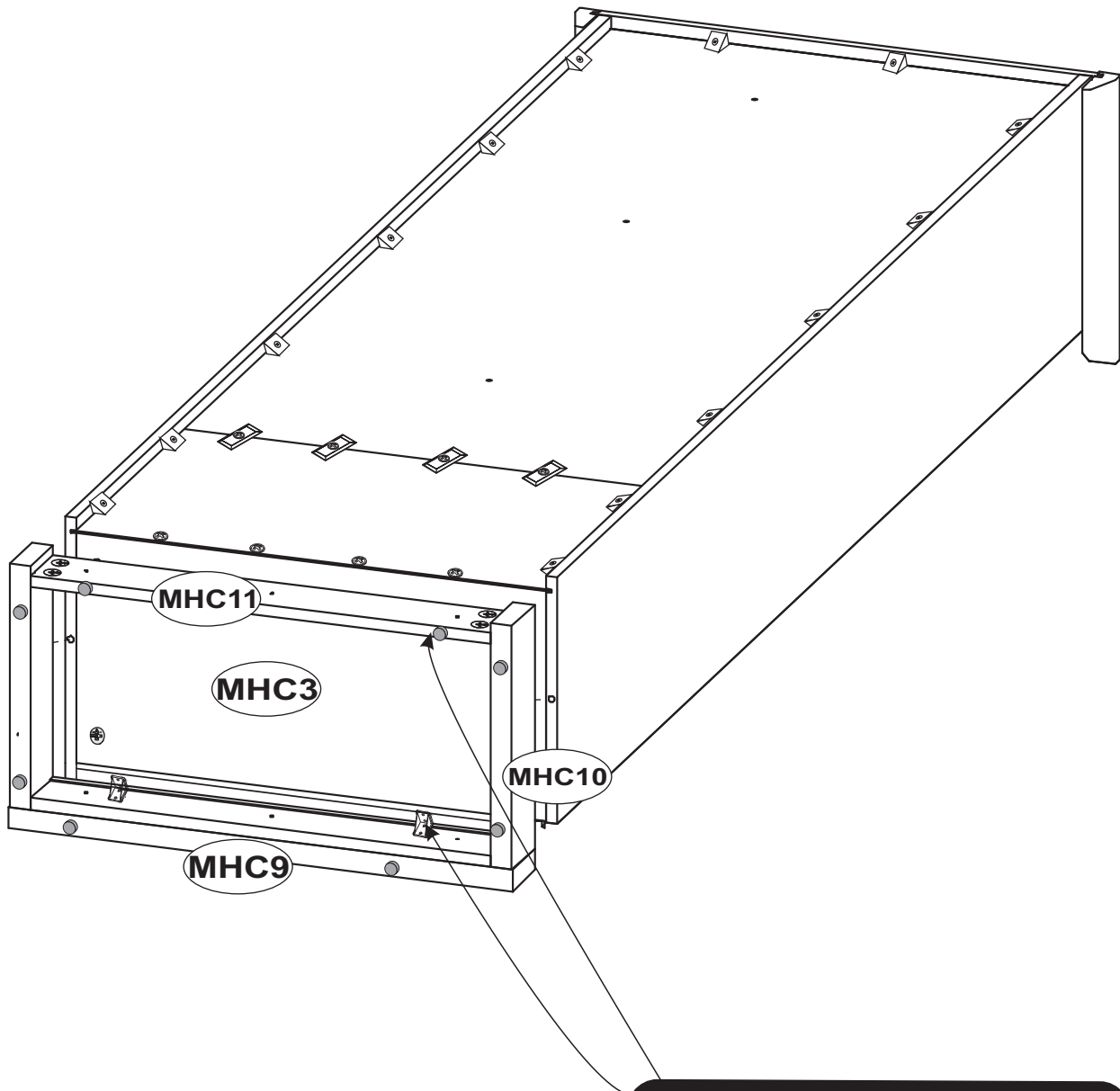



16

Option Left

| | | | |
|-------|---|--------|----|
| HCG54 |  | 126680 | x1 |
| HCP2 |  | 1014 | x1 |
| | | 3,5x13 | x1 |

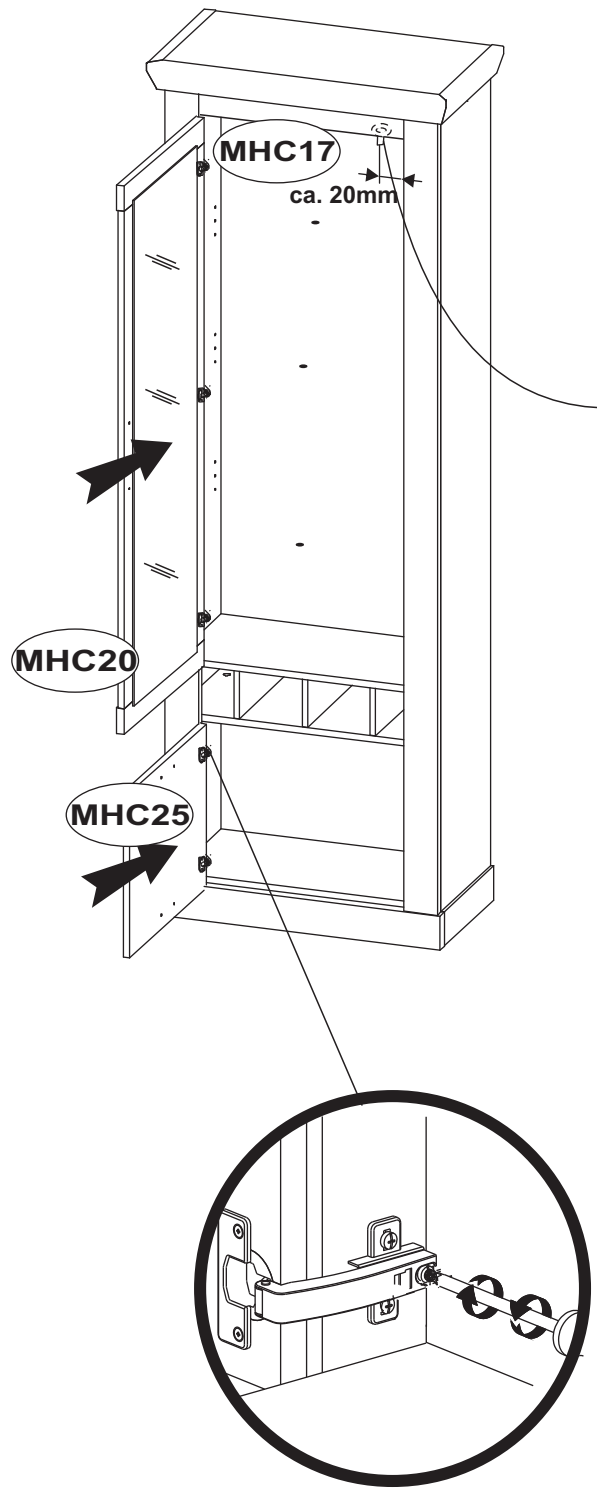

Option Right

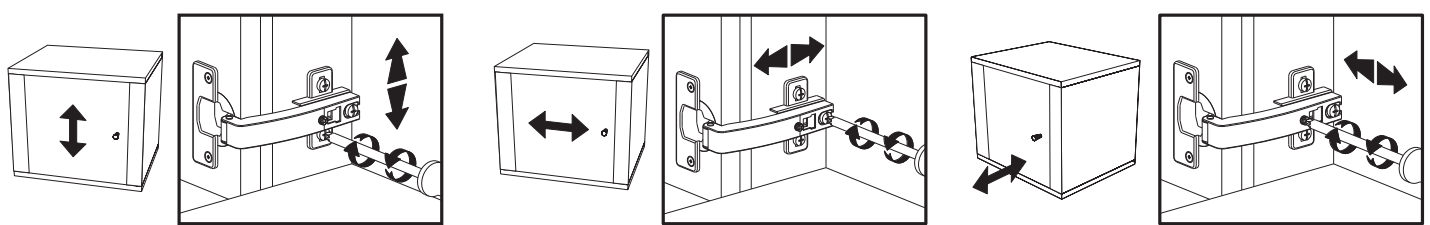
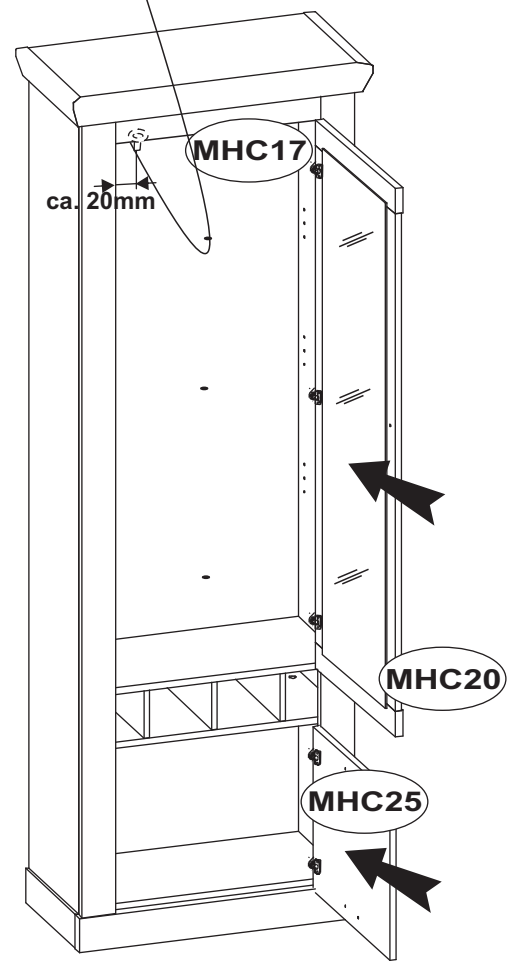

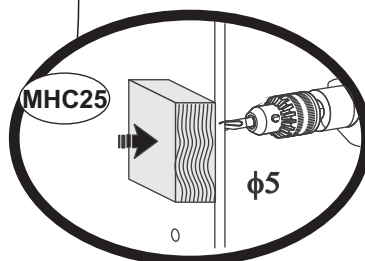
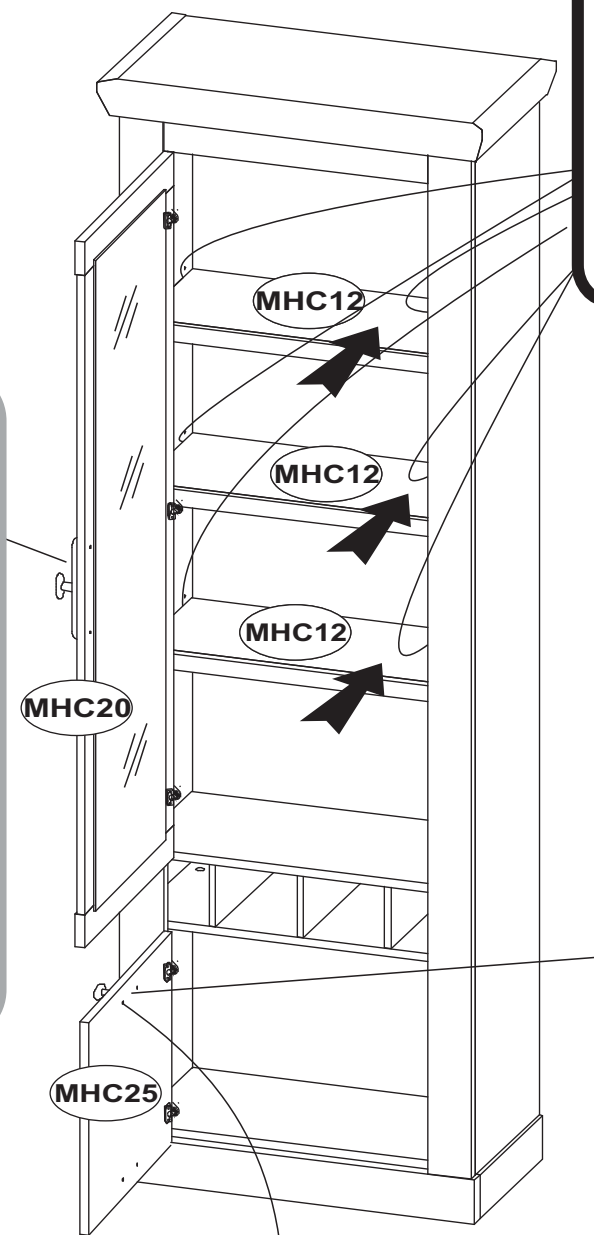
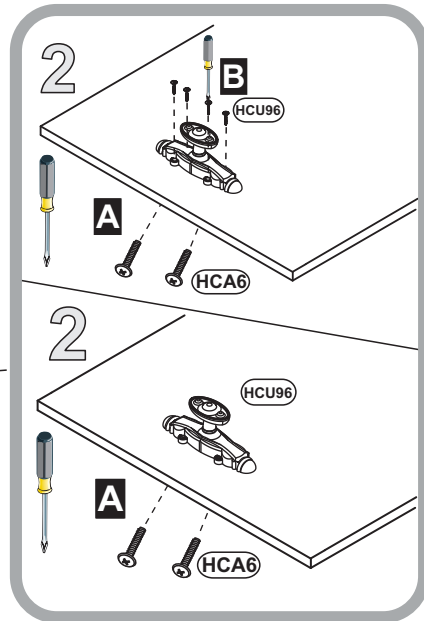
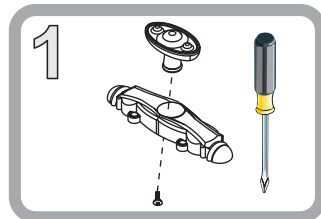
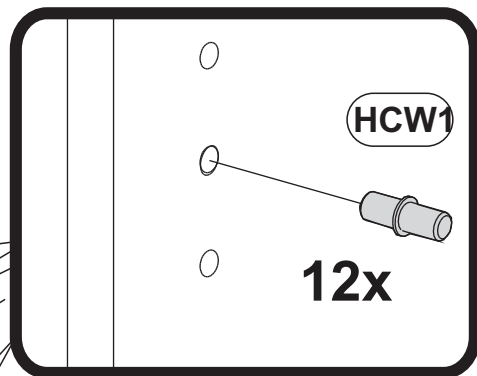
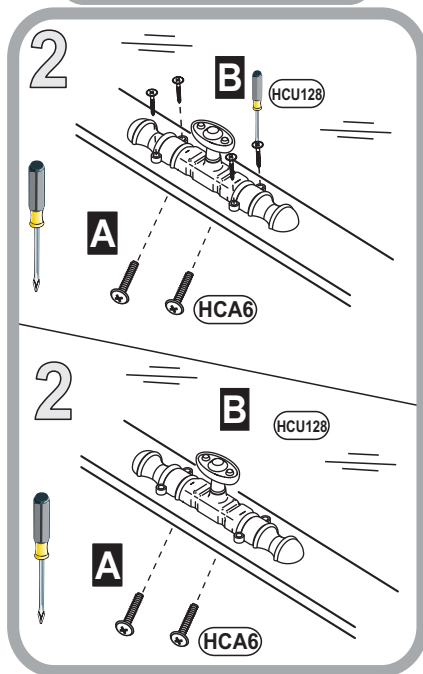
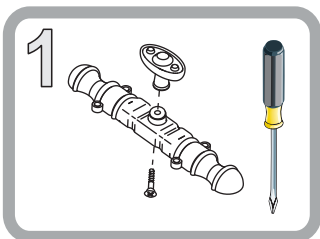
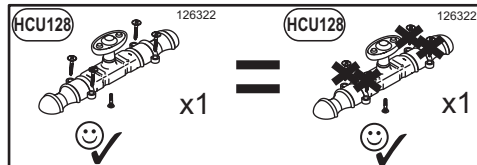
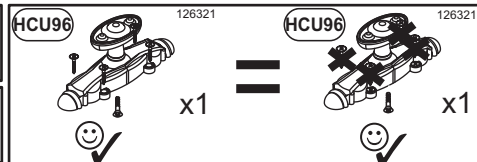
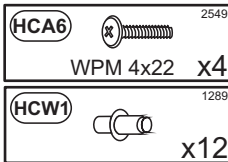

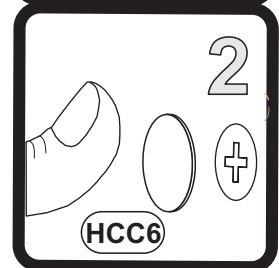
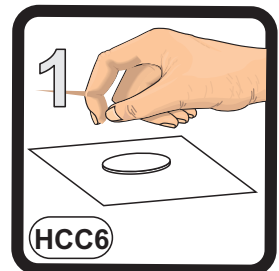
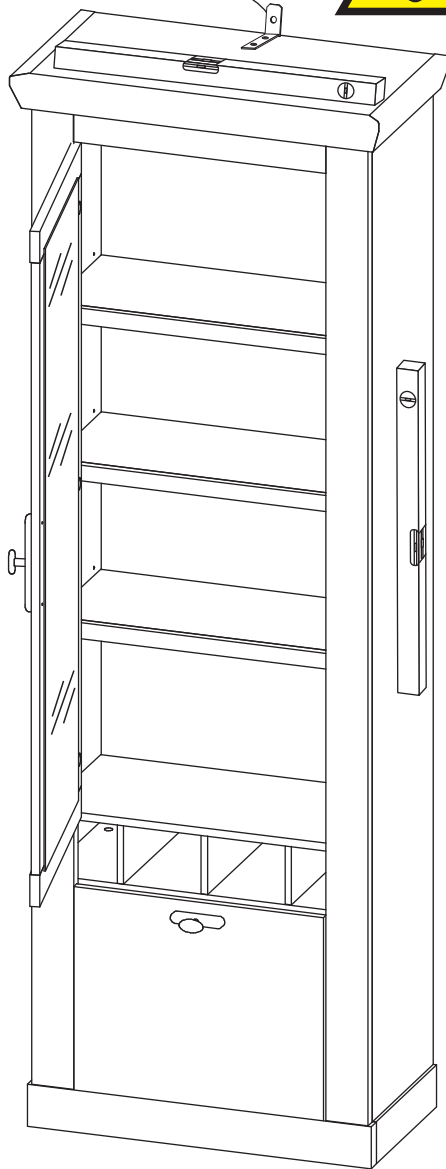
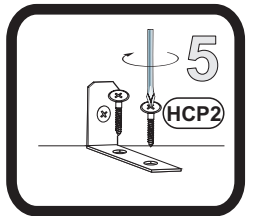
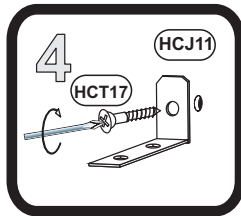
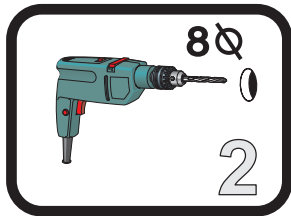
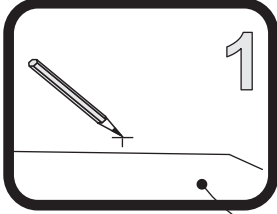
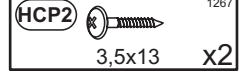
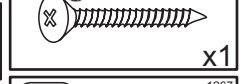
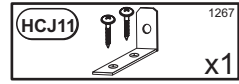
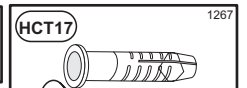
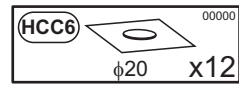
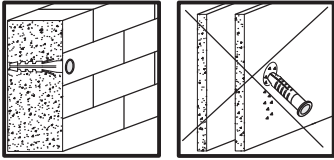

FLORENZ 23M

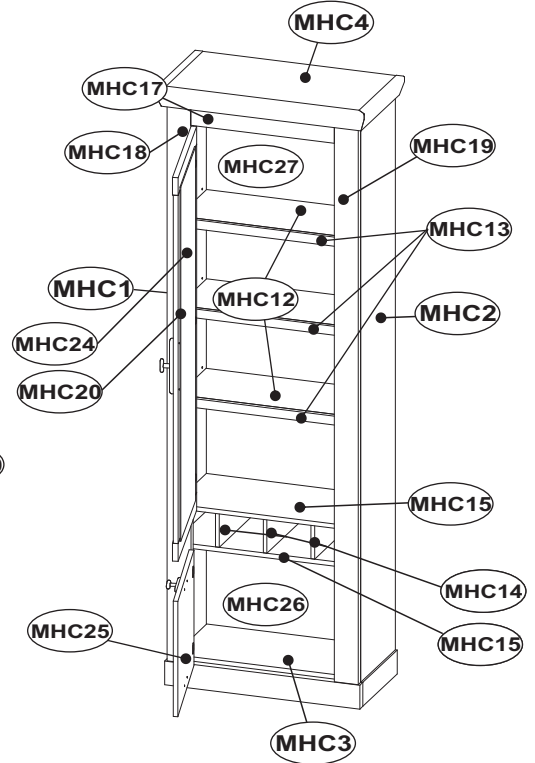
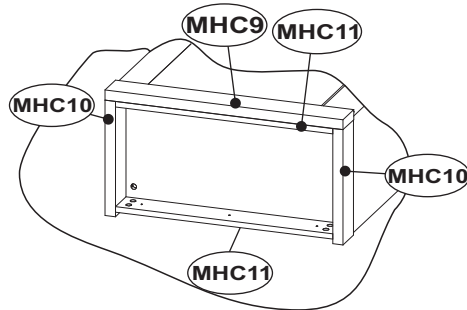

- D** Unser Direktservice für Beschlagteile
Sollte Ihnen ein Beschlagteil fehlen, können Sie diese Servicekarte direkt an die untenstehende Adresse mailen. Wir können allerdings nur Beschlagteile auf diesem Wege verschicken. Sollten Sie eine andere Beanstandung an Ihrem Möbelstück haben, so wenden Sie sich bitte direkt an Ihr Möbelhaus.
- GB** Our direct order service for fittings
If a fitting part is missing, you can e-mail this service card directly to the address below. However, we can only send fitting parts in this way. If you have any other cause for complaint concerning your item of furniture, please contact your furniture store directly.
- CZ** Naše přímé služby pro kování
Chybí-li vám nějaký díl z kování, můžete tuto servisní kartu odeslat e-mailem přímo na níže uvedenou adresu. Touto cestou však můžeme zoslat jen díly kování. Pokud byste reklamovali jiný díl nábytku, obraťte se přímo na svého prodejce nábytku.
- F** Bien étudier la notice de montage
S'il vous manque une ferrure, veuillez envoyer directement la présente carte service à l'adresse e-mail indiquée ci-dessous. Cependant, ceci nous permet uniquement d'envoyer des ferrures. Pour tout autre type de réclamation concernant votre meuble, veuillez contacter directement votre magasin d'ameublement.
- I** Il nostro servizio diretto per l'ordine della ferramenta
Qualora Vi dovesse mancare un pezzo di fissaggio, allora Vi preghiamo di inviare questa carta di servizio immediatamente all'indirizzo sottostante. Possiamo inviare i pezzi di fissaggio solamente per mezzo di questo procedimento. Qualora dovete avere qualche altra reclamazione in merito al mobile, allora Vi preghiamo di rivolgerVi direttamente al Vostro Negozio di mobili.
- BG** Нашата директна услуга за обкове
Ако липсват части от комплекта, попълнете настоящата сервисна карта и ни я изпратете на e-mail адреса, посочен по-долу. По този начин можем да доставяме само липсващи елементи от обкова. Ако установите други дефекти по мебелите, Ви съветваме да се обърнете към мебелната къща/магазин, от който сте закупили стоката.
- NL** Onze directservice voor losse onderdelen
Wanneer er een onderdeel ontbreekt, kunt u deze servicekaart direct aan onderstaand e-mailadres sturen. Wij kunnen langs deze weg echter alleen beslagdelen versturen. Mocht u een ander probleem aan uw meubel hebben, verzoeken wij u contact op te nemen met uw meubeldealer.
- PL** Nasz bezpośredni serwis części montażowych
Jeżeli brakuje części koniecznych do montażu, prosimy o przesłanie nam niniejszej karty serwisowej na niżej podany adres e-mailowy. W ten sposób możemy przelać Państwu tylko brakujące części. W przypadku innych reklamacji dotyczących mebla, prosimy zgłosić się do salonu meblowego, w którym został dokonany zakup.
- HR** Servis za okove
U slučaju da nedostaje neki od dijelova molimo vas da na dolje navedenu mail adresu pošaljete ovaj servisni obvezac. Na ovaj način mogu se dostaviti samo okovi. U slučaju da imate dodatne prigovore vezane uz komad namještaja molimo vas da se obratite izravno trgovini namještaja gdje je isti kupljen.
- HU** Direktszolgálatunk vasalatók esetén
Ha hiányzik egy vasalató, ezt a kártyát közvetlenül elküldheti az alább található címre. Azonban csakis vasalatókat tudunk így küldeni. Amennyiben másfajta reklamáció áll fenn bútordarabjait illetően, forduljon közvetlenül a bútortárházhoz.
- SK** Naš priamy servis pre časti kovania
Ak by Vám chýbala nejaká časť kovania, môžete poslať túto servisnú kartu poslať e-mailom na nižšie uvedenú adresu. Diely kovania vieme poslať iba týmto spôsobom. Ak by ste mali inú reklamáciu ohľadom Vašho nábytku, obráťte sa priamo na Vašu predajňu nábytku.
- SLO** Naše direktne uslužne storitve za okovje
Če vam manjka kakšno okovje, lahko to servisno kartico pošljete po e-pošti direktno na spodnji naslov. Po tej poti vam lahko pošljemo samo okovje. Če želite reklamirati kakšen drug del pohištva, se obrnite neposredno na vašo trgovino pohištva.
- RO** Service-ul nostru direct pentru feronerie
În cazul în care vă lipsește o piesă de feronerie puteți să trimiteți direct acest card de service prin e-mail la adresa de mai jos. Noi nu putem expedia piese de feronerie decât pe această cale. Dacă aveți o altă reclamație referitoare la piesa de mobilier, atunci vă rugăm să vă adresați direct la magazinul dvs. de mobilă.
- RUS** Наш прямой сервис для поставок фурнитуры
Если окажется, что Вам не хватает того или иного элемента фурнитуры, Вы можете отправить сервисную карту по факсу непосредственно на нижеприведенный адрес электронной почты. Однако, таким образом мы можем переслать лишь фурнитуру. Если же у Вас возникнут иные претензии относительно приобретенной мебели, пожалуйста, обращайтесь непосредственно в организацию, осуществлявшую продажу.
- S** Vår direktservice för beslagsdelar
Om du saknar en beslagsdel kan du skicka detta servicekort direkt till e-postadressen som anges nedan. Tänk på att detta är den enda möjligheten att skicka beslagsdelar till dig. Om du vill reklamera din möbel av en annan anledning måste du kontakta ditt möbelhus direkt.
- ES** Nuestro servicio directo para accesorios
Si le falta algún accesorio, puede enviar esta tarjeta de servicio directamente a la siguiente dirección. No obstante, por este método solo podemos enviar accesorios. Si tiene alguna otra objeción sobre su mueble, consulte directamente con su mueblería.
- TR** Donatılar için doğrudan servisimiz
Bir donatınız eksikse bu servis kartını doğrudan aşağıda bulunan adrese doğrudan mail yazabilirsiniz. Sadece bu yolla donatılar gönderilebilir. Mobilyanızda başka şikayetleriniz varsa lütfen doğrudan mobilya satıcınıza danışın.

| | | | | | | | | | |
|-------|------|-------|----|-----|-------|------|-----|----|-----|
| MHC1 | 1911 | 320 | 15 | 2/2 | MHC17 | 483 | 120 | 18 | 2/2 |
| MHC2 | 1911 | 320 | 15 | 2/2 | MHC18 | 1911 | 80 | 22 | 2/2 |
| MHC3 | 611 | 299 | 15 | 1/2 | MHC19 | 1911 | 80 | 22 | 2/2 |
| MHC4 | 699 | 370,5 | 65 | 1/2 | MHC20 | 1279 | 477 | 18 | 2/2 |
| MHC9 | 655 | 80 | 28 | 1/2 | MHC24 | 1189 | 386 | 4 | 2/2 |
| MHC10 | 317 | 80 | 28 | 1/2 | MHC25 | 388 | 477 | 15 | 2/2 |
| MHC11 | 598 | 80 | 15 | 1/2 | MHC26 | 385 | 623 | 3 | 2/2 |
| MHC12 | 610 | 267 | 15 | 1/2 | MHC27 | 1531 | 623 | 3 | 2/2 |
| MHC13 | 608 | 30 | 16 | 1/2 | | | | | |
| MHC14 | 112 | 298 | 15 | 1/2 | | | | | |
| MHC15 | 611 | 299 | 15 | 1/2 | | | | | |

FLORENZ 23M

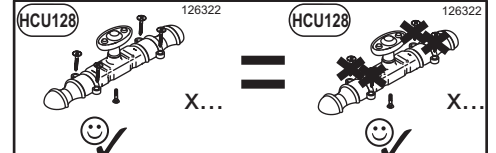
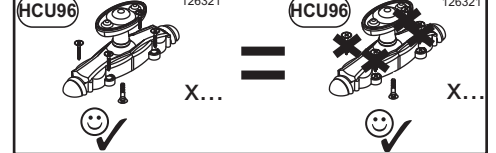
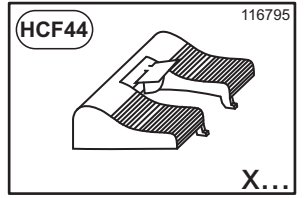
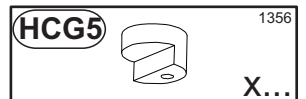
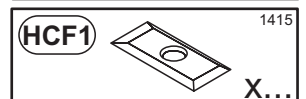
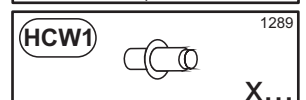
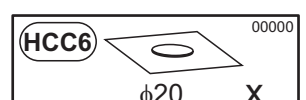
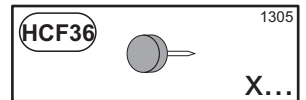
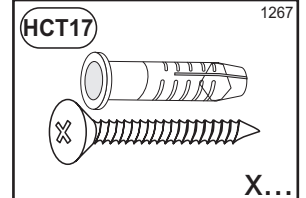
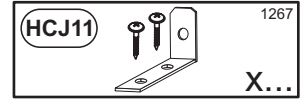
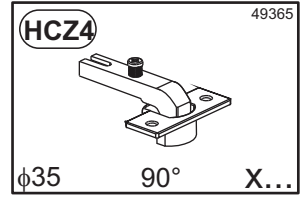
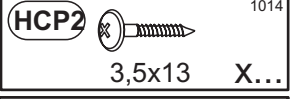
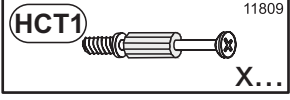
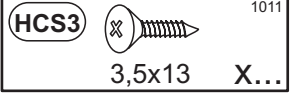
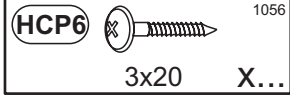
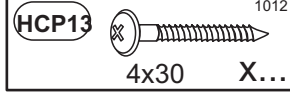
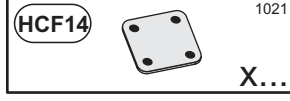
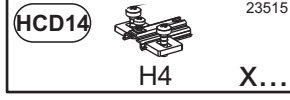
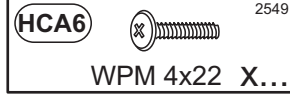
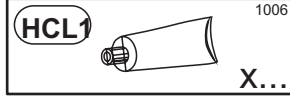
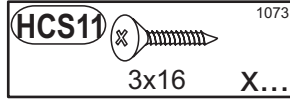
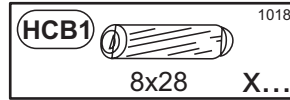
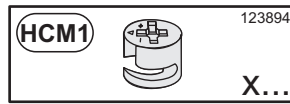

D Unser Direktservice für Beschlagteile
Sollte Ihnen ein Beschlagteil fehlen, können Sie diese Servicekarte direkt an die untenstehende Adresse mailen. Wir können allerdings nur Beschlagteile auf diesem Wege verschicken. Sollten Sie eine andere Beanspruchung an Ihrem Möbelstück haben, so wenden Sie sich bitte direkt an Ihr Möbelhaus.

GB Our direct order service for fitting
If a fitting part is missing, you can e-mail this service card directly to the address below. However, we can only send fitting parts in this way. If you have any other cause for complaint concerning your item of furniture, please contact your furniture store directly.

CZ Naše přímé služby pro kování
Chybí-li vám nějaký díl z kování, můžete tuto servisní kartu odeslat e-mailem přímo na níže uvedenou adresu. Touto cestou však můžeme zoslat jen díly kování. Pokud byste reklamovali jiný díl nábytku, obraťte se přímo na svého prodejce nábytku.

F Bien étudier la notice de montage
S'il vous manque une ferrure, veuillez envoyer directement la présente carte service à l'adresse e-mail indiquée ci-dessous. Cependant, ceci nous permet uniquement d'envoyer des ferrures. Pour tout autre type de réclamation concernant votre meuble, veuillez contacter directement votre magasin d'ameublement.

I Il nostro servizio diretto per l'ordine della ferramenta
Qualora Vi dovesse mancare un pezzo di fissaggio, allora Vi preghiamo di inviare questa carta di servizio immediatamente all'indirizzo sottostante. Possiamo inviare i pezzi di fissaggio solamente per mezzo di questo procedimento. Qualora dovesse avere qualche altra reclamazione in merito al mobile, allora Vi preghiamo di rivolgerVi direttamente al Vostro Negozio di mobili.

BG Нашата директна услуга за обкова
Ако липсват части от комплекта, попълнете настоящата сервисна карта и ни я изпратете на e-mail адреса, посочен по-долу. По този начин можем да доставим само липсващи елементи от обкова. Ако установите други дефекти по мебелите, Ви съветваме да се обърнете към мебелната къща/магазин, от който сте закупили стоката.

NL Onze directservice voor losse onderdelen
Wanneer er een onderdeel ontbreekt, kunt u deze servicekaart direct aan onderstaand e-mailadres sturen. Wij kunnen langs deze weg echter alleen beslagdelen versturen. Mocht u een ander probleem aan uw meubel hebben, verzoeken wij u contact op te nemen met uw meubeldealer.

PL Nasz bezpośredni serwis czeski montażowych
Jeżeli brakuje części koniecznych do montażu, prosimy o przesłanie nam niniejszej karty serwisowej na niżej podany adres e-mailowy. W ten sposób możemy przelać Państwu tylko brakujące części. W przypadku innych reklamacji dotyczących mebla, prosimy zgłosić się do salonu meblowego, w którym został dokonany zakup.

HR Servis za okove
U slučaju da nedostaje neki od dijelova molimo vas da na dolje navedenu mail adresu pošaljete ovaj servisni obrazac. Na ovaj način mogu se dostaviti samo okovi. U slučaju da imate dodatne prigovore vezane uz komad namještaja molimo vas da se obratite izravno trgovini namještaja gdje je isti kupljen.

HU Direktszolgálatunk vasalatok esetén
Ha hiányzik egy vasalat, ezt a kártyát közvetlenül elküldheti az alább található címre. Azonban csakis vasalatoskat tudunk így küldeni. Amennyiben másfajta reklamáció áll fenn bútoráruházt illetően, forduljon közvetlenül a bútorházhöz.

SK Naš priamy servis pre časti kovania
Ak by Vám chýbala nejaká časť kovania, môžete poslať túto servisnú kartu pošťou na nižšie uvedenú adresu. Díly kovania vieme poslať iba týmto spôsobom. Ak by ste mali inú reklamáciu ošahdom Vášho nábytku, obráťte sa priamo na Vašu predajňu nábytku.

SLO Naše direktne uslužne storitve za okovje
Če vam manjka kakšno okovje, lahko to servisno kartico pošljete po e-pošti direktno na spodnji naslov. Po taj poti vam lahko pošljemo samo okovje. Če želite reklamirati kakšen drug del pohištva, se obrnite neposredno na vašo trgovino pohištva.

RO Service-ul nostru direct pentru feronerie
În cazul în care vă lipsește o piesă de feronerie puteți să trimiteți direct acest card de service prin e-mail la adresa de mai jos. Noi nu putem expedia piese de feronerie decât pe această cale. Dacă aveți o altă reclamație referitoare la piesa de mobilier, atunci vă rugăm să vă adresați direct la magazinul dvs. de mobilier.

RUS Наш прямой сервис для поставок фурнитур
Если окажется, что Вам не хватает того или иного элемента фурнитуры, Вы можете отправить сервисную карту по факсу непосредственно на нижеприведенный адрес электронной почты. Однако, таким образом мы можем пересылать лишь фурнитуру. Если же у Вас возникнут иные претензии относительно приобретенной мебели, пожалуйста, обращайтесь непосредственно в организацию, осуществившую продажу.

S Vi direktservice för beslagsdelar
Om du saknar en beslagsdel kan du skicka detta servicekort direkt till e-postadressen som anges nedan. Tänk på att detta är den enda möjligheten att skicka beslagsdelar till dig. Om du vill reklamera din möbel av en annan anledning måste du kontakta ditt möbelhus direkt.

ES Nuestro servicio directo para accesorios
Si le falta algún accesorio, puede enviar esta tarjeta de servicio directamente a la siguiente dirección. No obstante, por este método solo podemos enviar accesorios. Si tiene alguna otra objeción sobre su mueble, consulte directamente con su mueblería.

TR Donatılar için doğrudan servisimiz
Bir donatınız eksikse bu servis kartını doğrudan aşağıda bulunan adrese doğrudan mail yazabilirsiniz. Sadece bu yolla donatılar gönderiliriz. Mobilyanızda başka şikayetleriniz varsa lütfen doğrudan mobilya satıcınıza danışın.

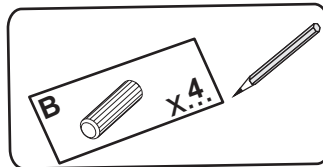

FLORENZ 51M

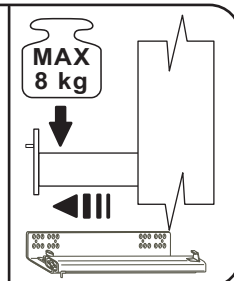
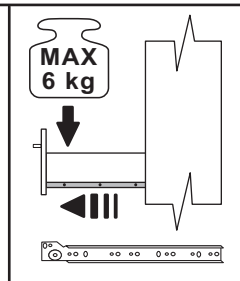
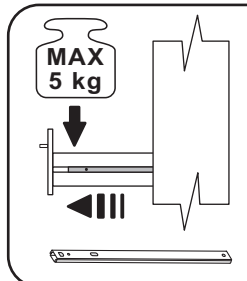
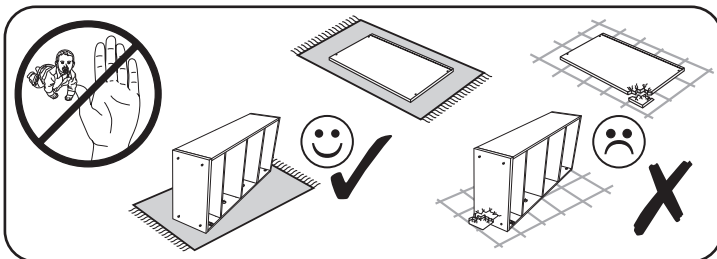
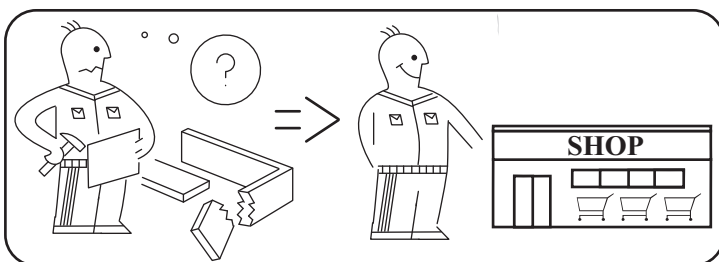
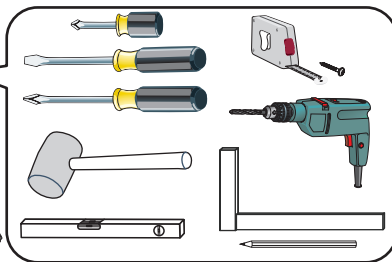
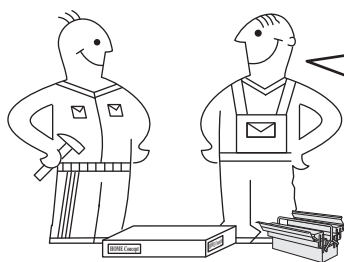
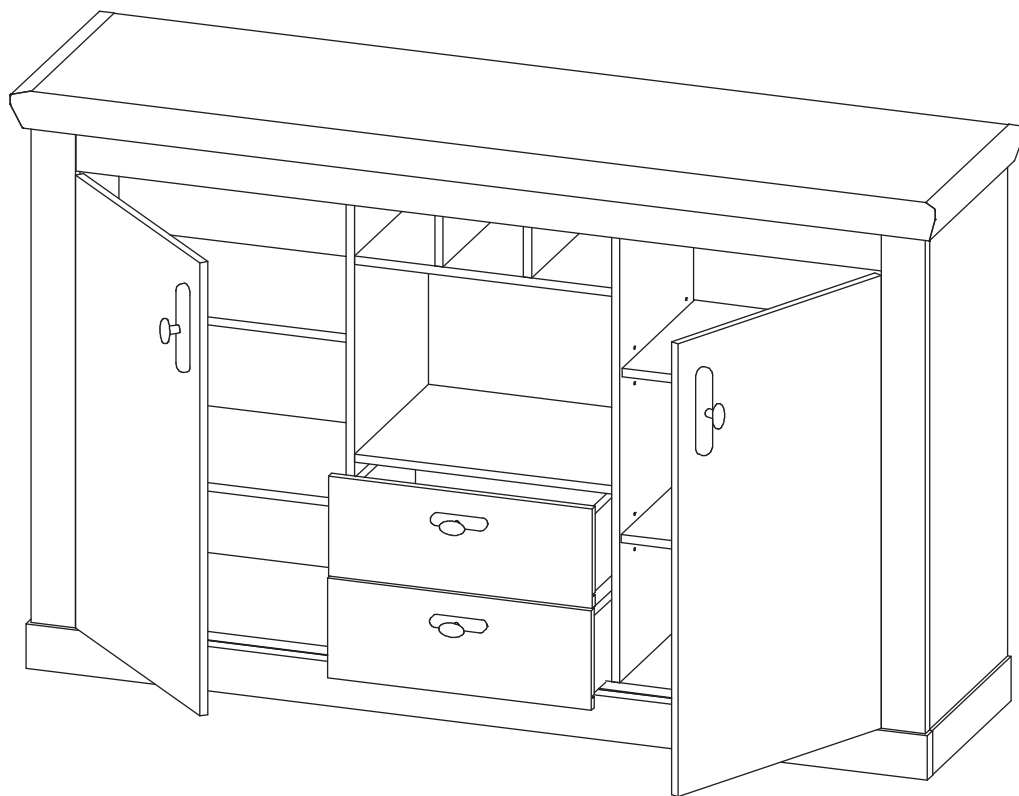
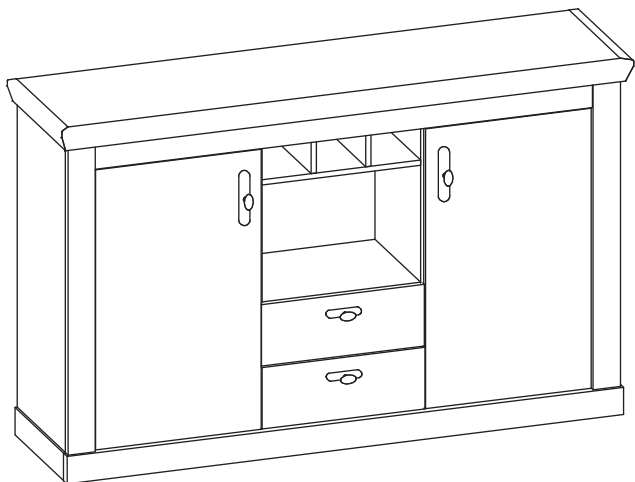
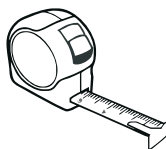

FLORENZ 51M

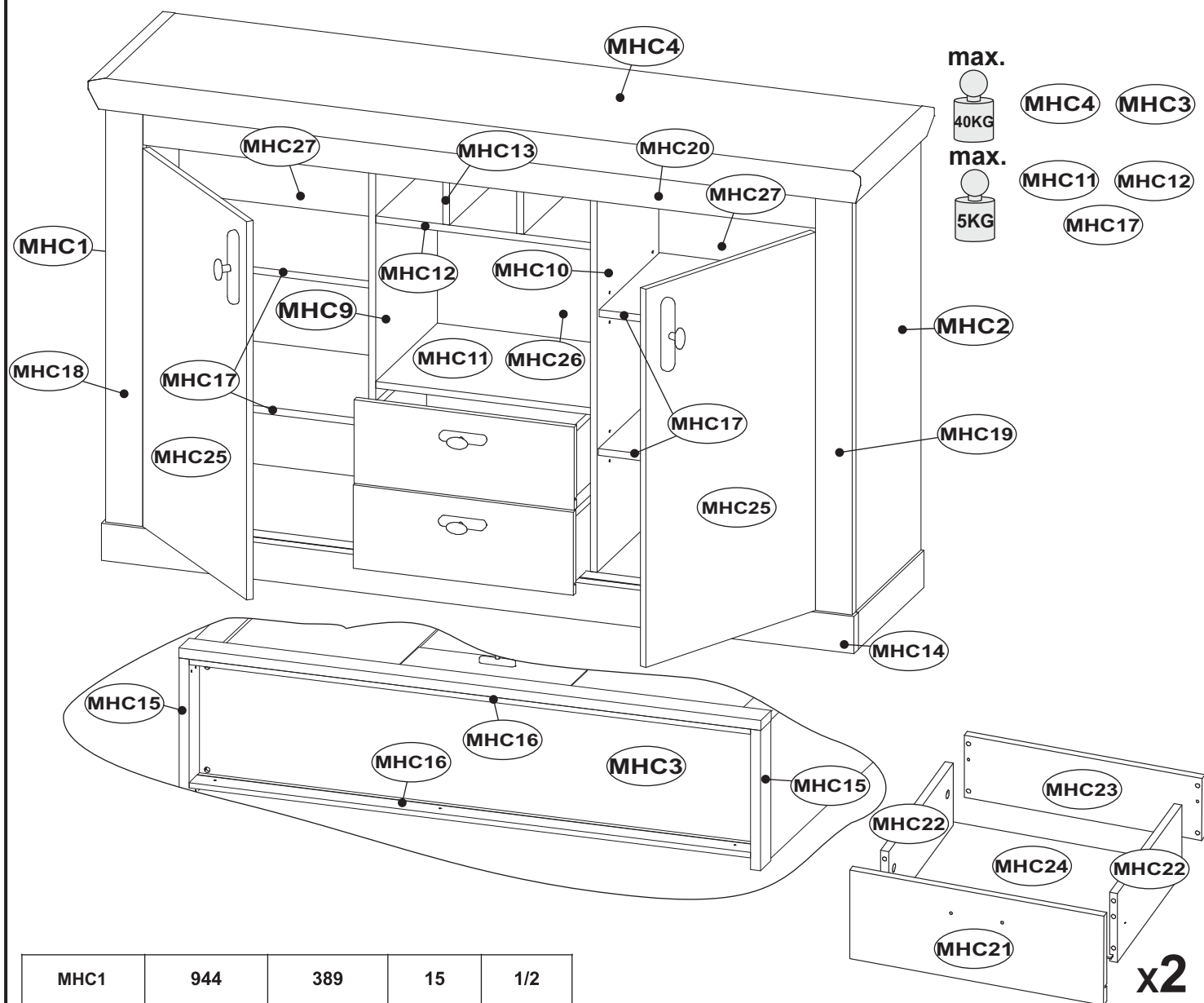

| | | | | |
|-------|------|-------|----|-----|
| MHC1 | 944 | 389 | 15 | 1/2 |
| MHC2 | 944 | 389 | 15 | 1/2 |
| MHC3 | 1583 | 369 | 15 | 2/2 |
| MHC4 | 1671 | 439,5 | 65 | 1/2 |
| MHC9 | 929 | 368 | 15 | 2/2 |
| MHC10 | 929 | 368 | 15 | 2/2 |
| MHC11 | 464 | 367 | 15 | 2/2 |
| MHC12 | 464 | 367 | 15 | 2/2 |
| MHC13 | 219 | 366 | 15 | 1/2 |
| MHC14 | 1627 | 80 | 28 | 2/2 |
| MHC15 | 386 | 80 | 28 | 2/2 |
| MHC16 | 1570 | 80 | 15 | 2/2 |

| | | | | |
|-------|------|-----|----|-----|
| MHC17 | 543 | 360 | 15 | 2/2 |
| MHC18 | 944 | 80 | 22 | 1/2 |
| MHC19 | 944 | 80 | 22 | 1/2 |
| MHC20 | 1455 | 120 | 18 | 2/2 |
| MHC21 | 477 | 180 | 15 | 1/2 |
| MHC22 | 332 | 140 | 15 | 1/2 |
| MHC23 | 445 | 126 | 15 | 1/2 |
| MHC24 | 426 | 354 | 3 | 1/2 |
| MHC25 | 818 | 484 | 15 | 1/2 |
| MHC26 | 949 | 478 | 3 | 2/2 |
| MHC27 | 949 | 558 | 3 | 2/2 |

FLORENZ 51M

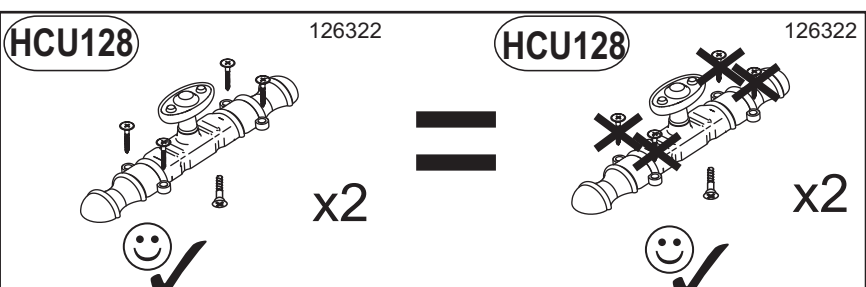
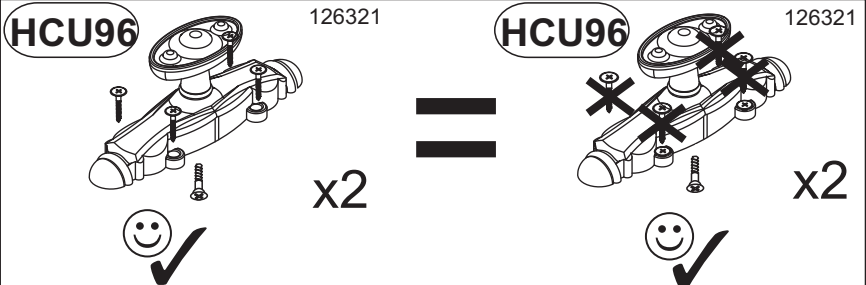
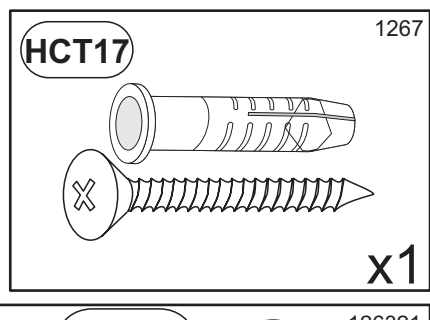
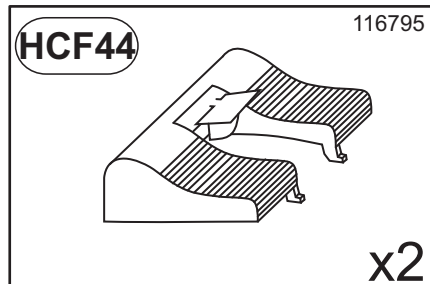
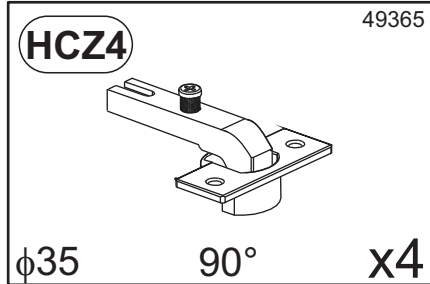
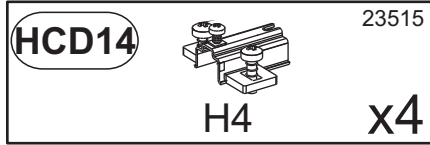
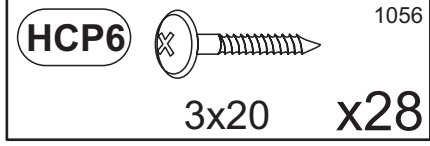
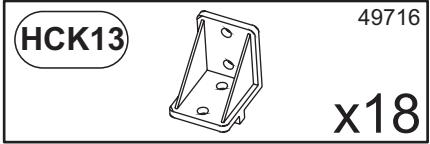
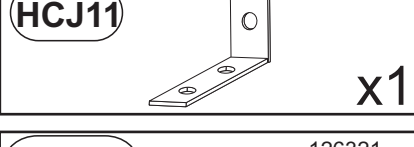
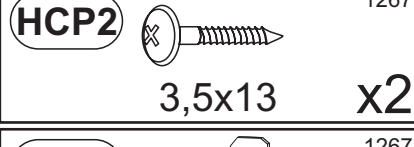
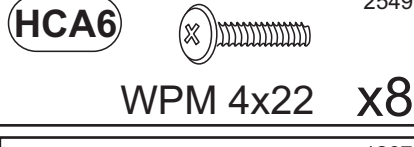
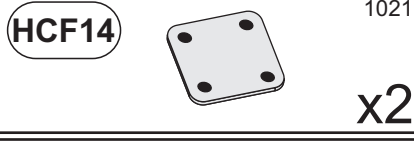
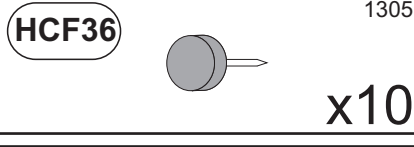
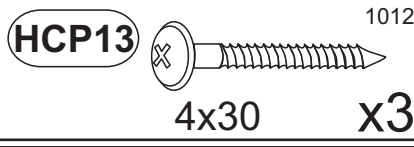
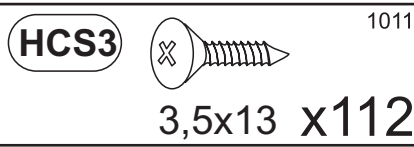
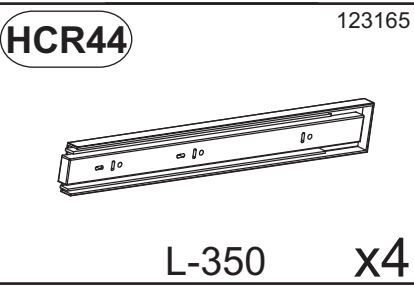
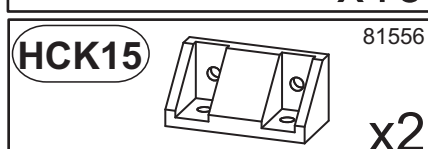
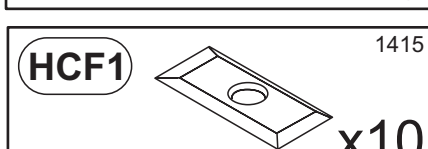
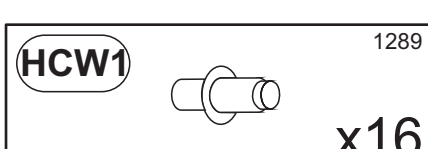
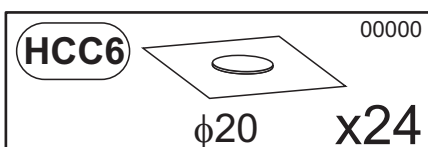
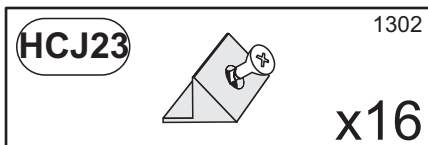
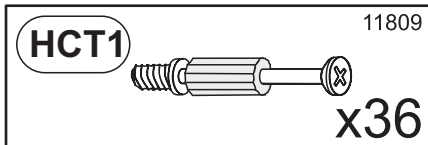
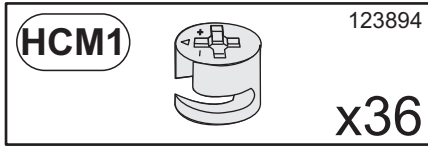
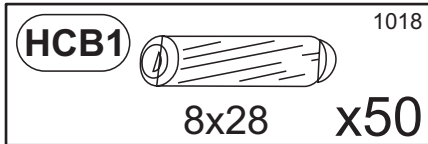

1

| | | |
|-------|--------|--------|
| HCB1 | | 1018 |
| | 8x28 | x16 |
| HCM1 | | 123894 |
| | | x8 |
| HCR44 | | 123165 |
| | L-350 | x4 |
| HCS3 | | 1011 |
| | 3,5x13 | x8 |

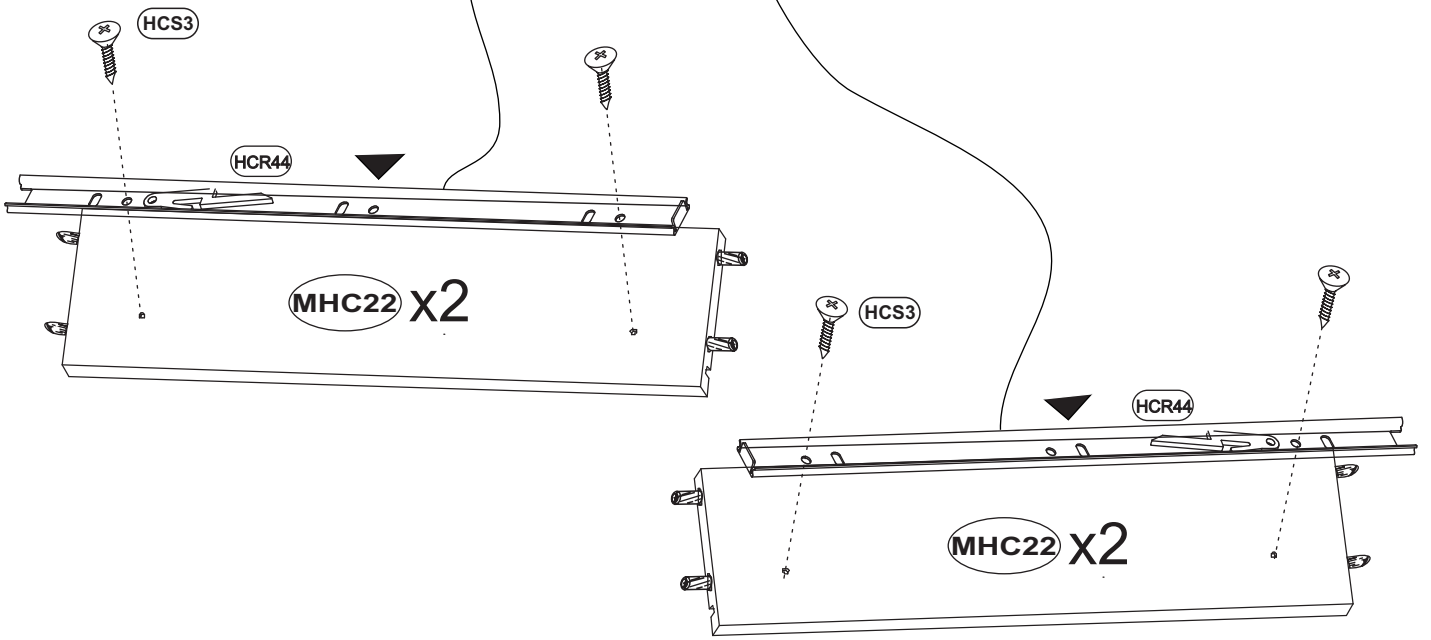
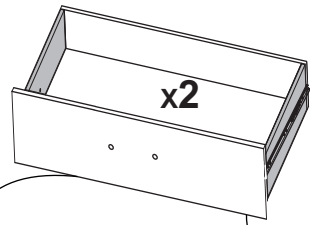
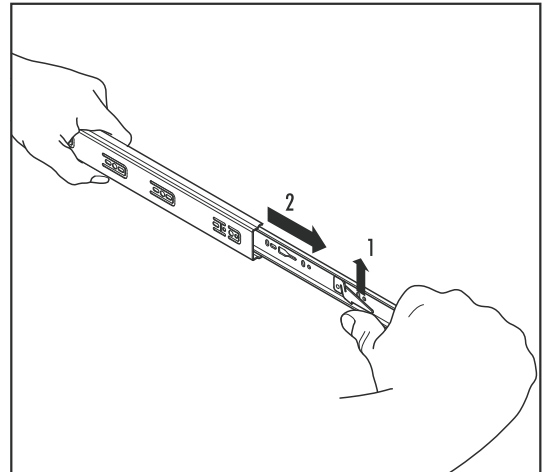
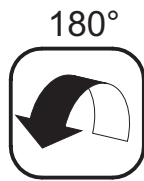
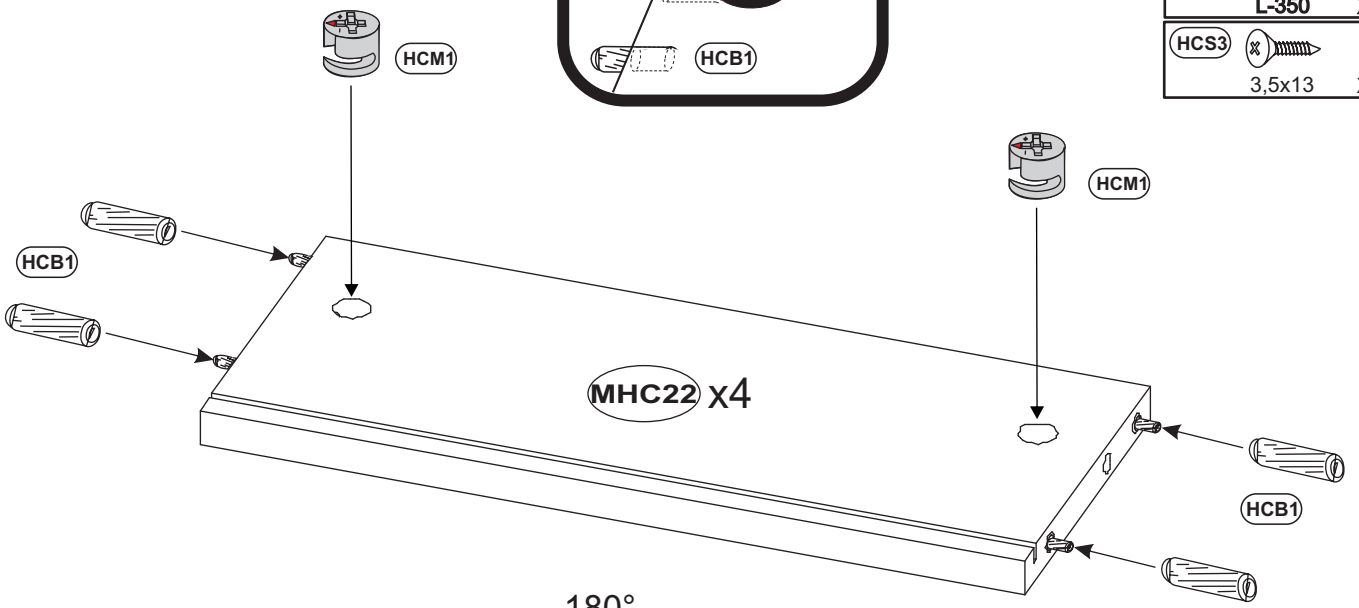
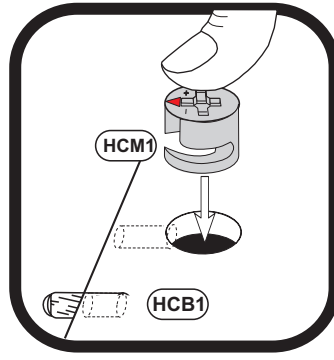

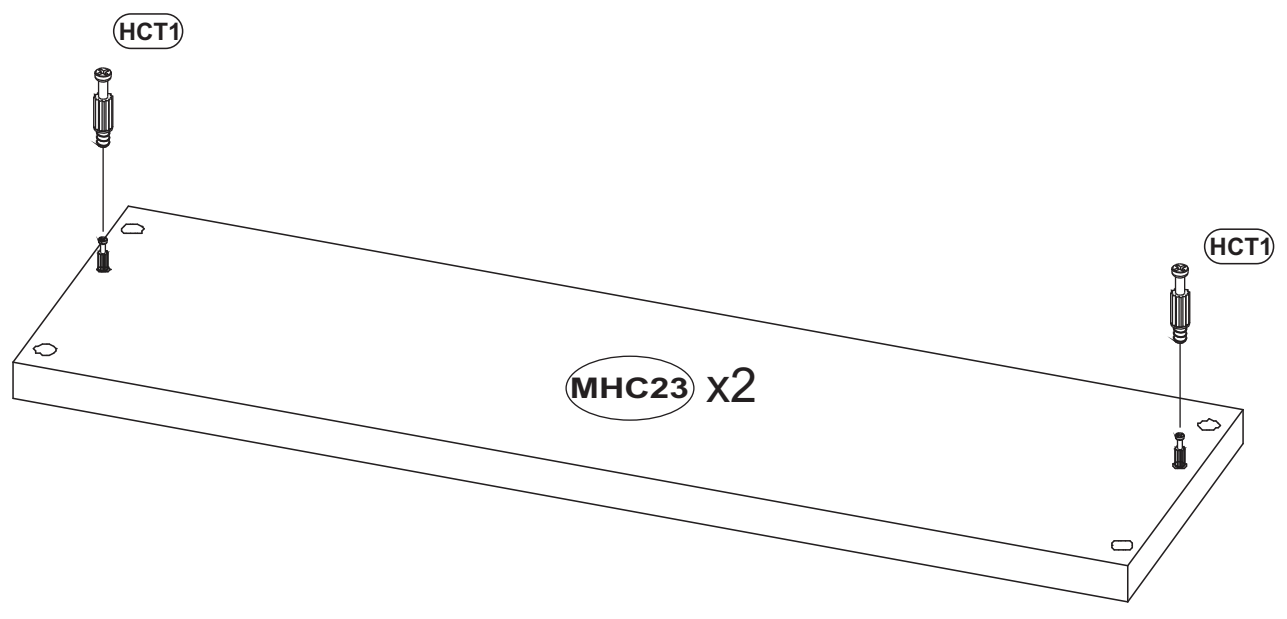
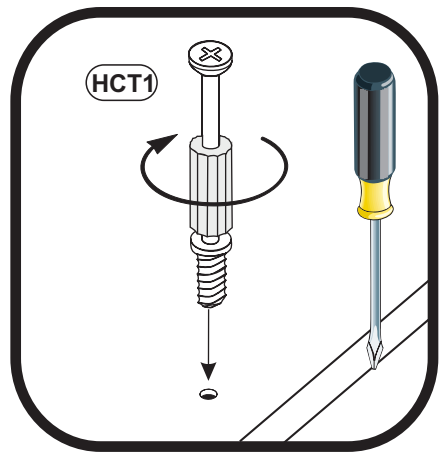
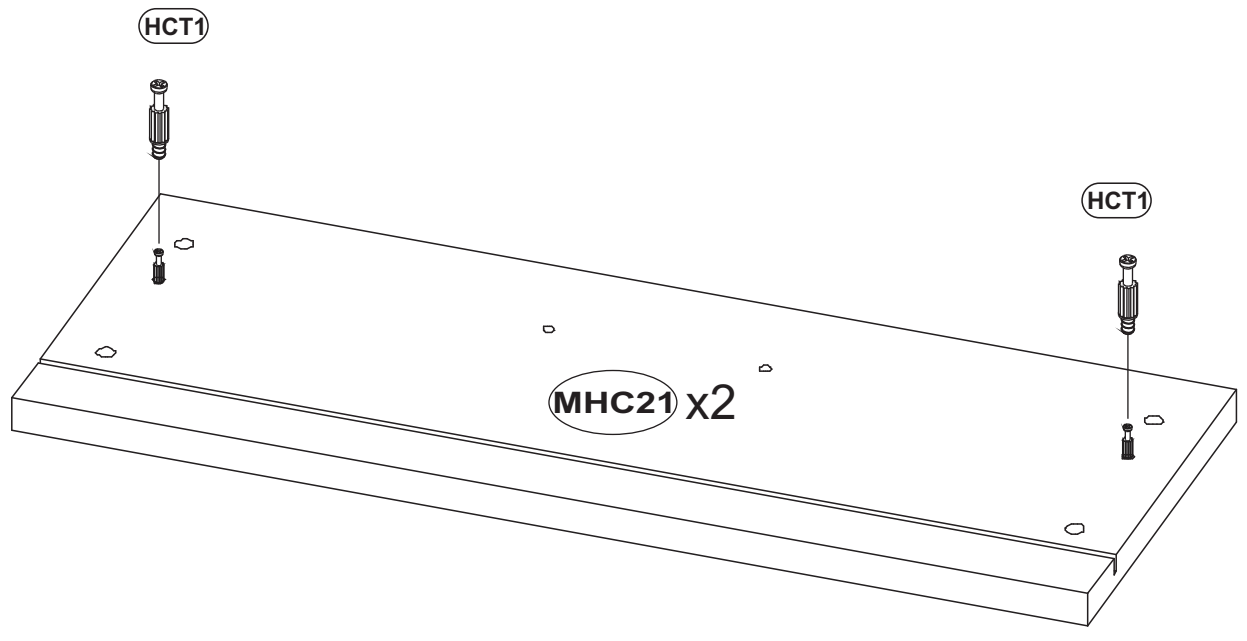

3

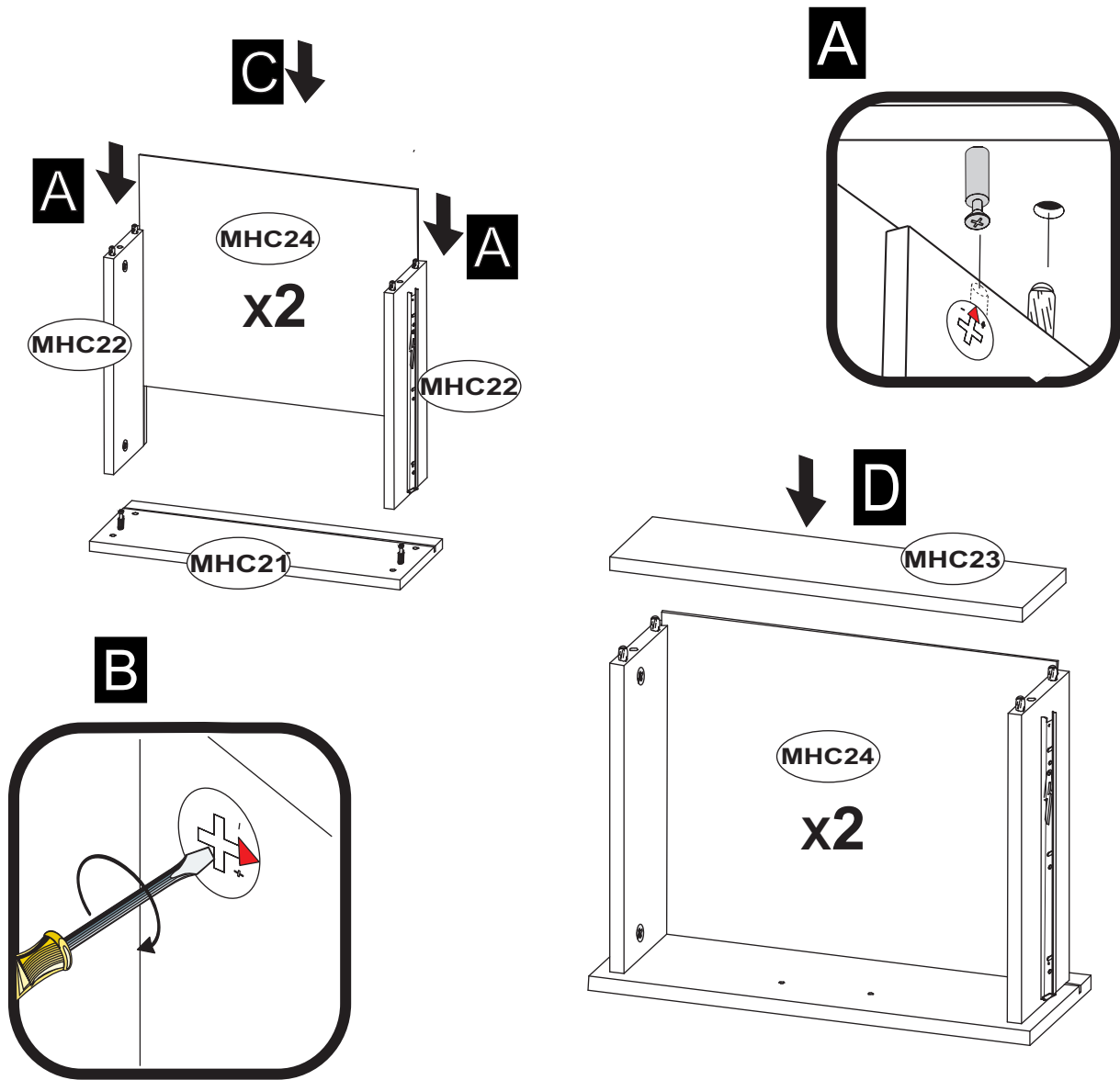

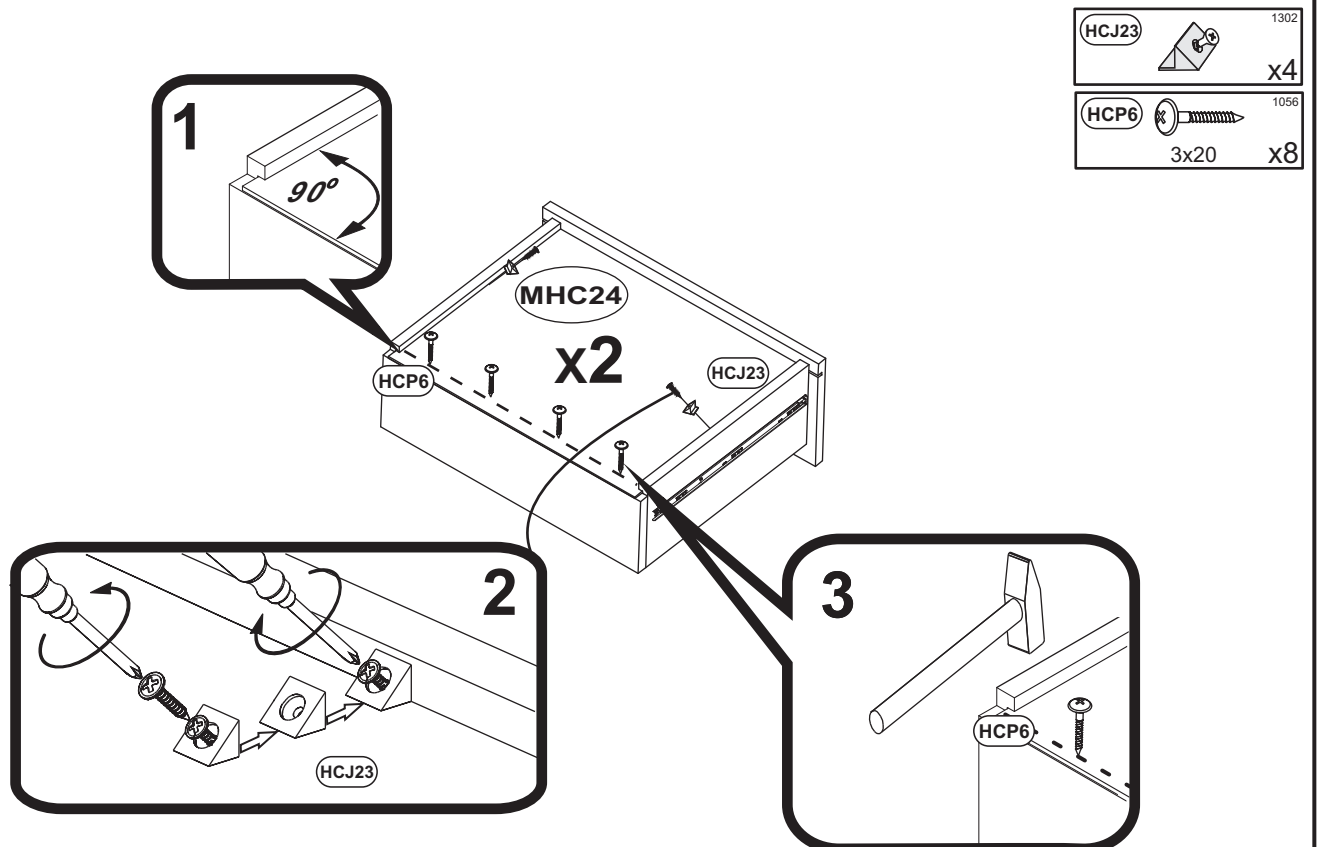

4

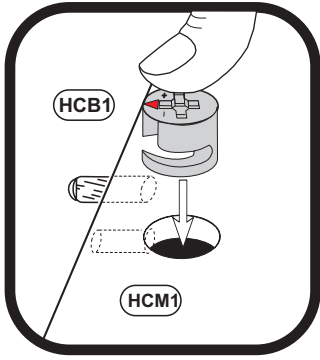

5

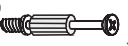

| | | |
|------|---|--------|
| HCB1 |  | 1018 |
| | 8x28 | x4 |
| HCM1 |  | 123894 |
| | | x4 |
| HCT1 |  | 11809 |
| | | x4 |

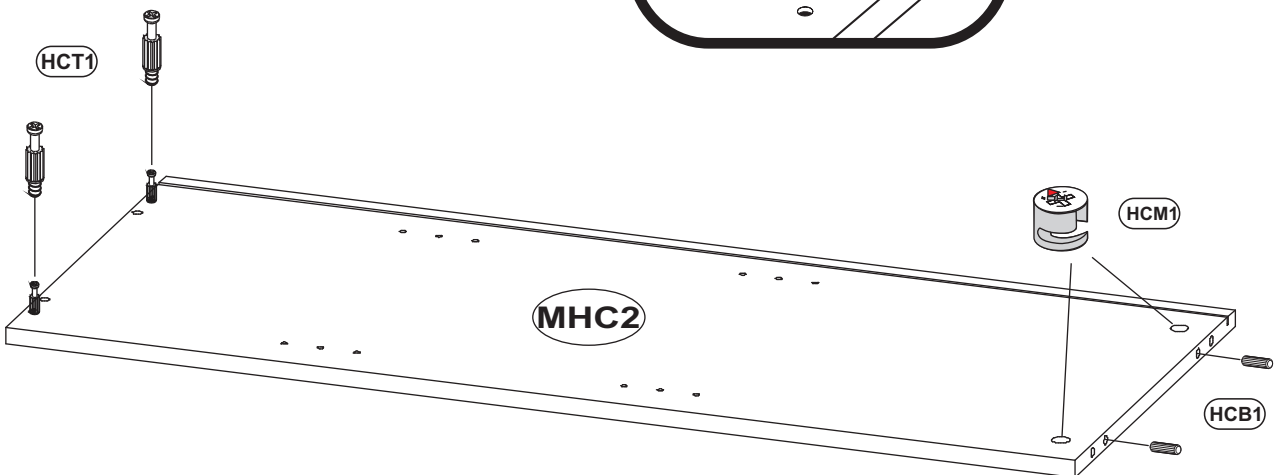
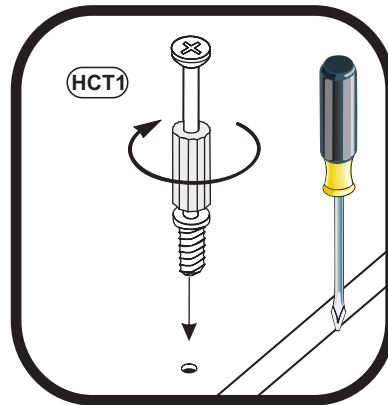
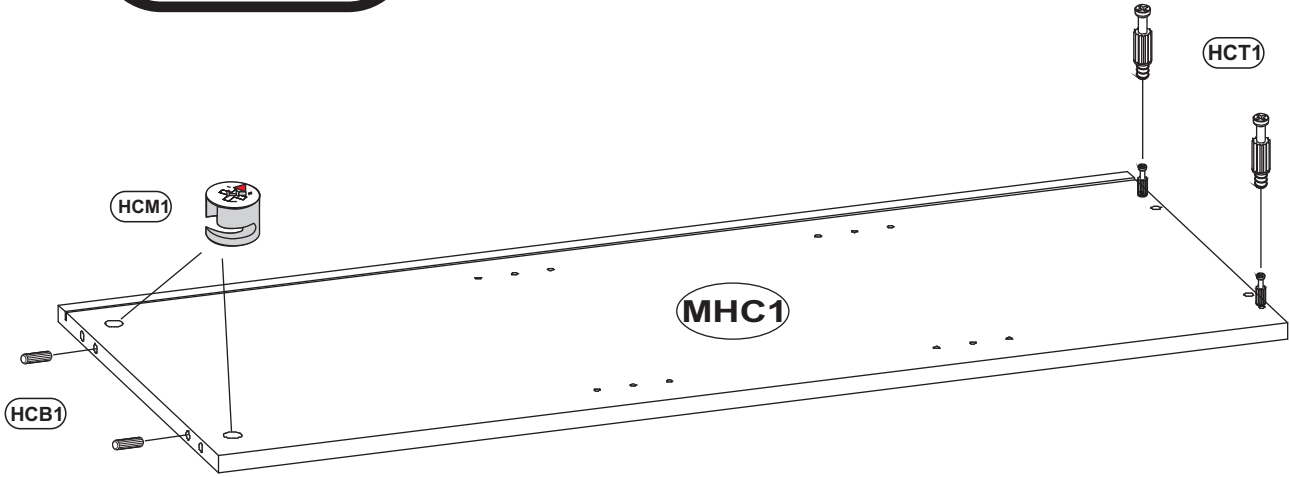

| | | |
|------|--------|------|
| HCS3 | | 1011 |
| | 3,5x13 | x8 |

| | | |
|------|--|--------|
| HCM1 | | 123894 |
| | | x8 |



| | | |
|------|--|-------|
| HCT1 | | 11809 |
| | | x4 |

| | | |
|------|------|------|
| HCB1 | | 1018 |
| | 8x28 | x8 |

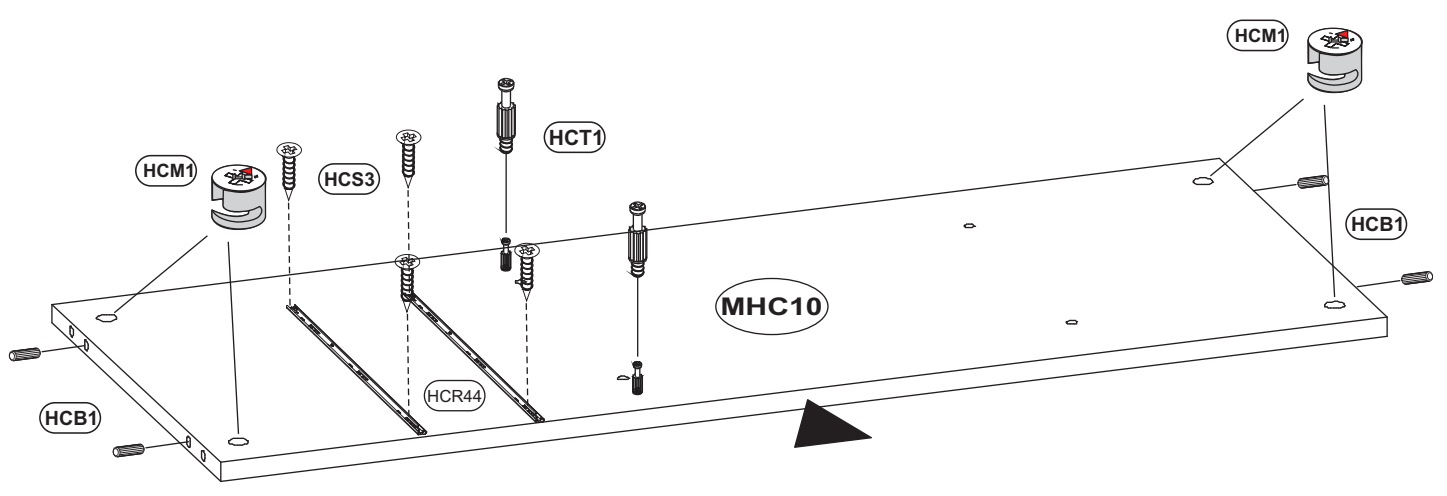
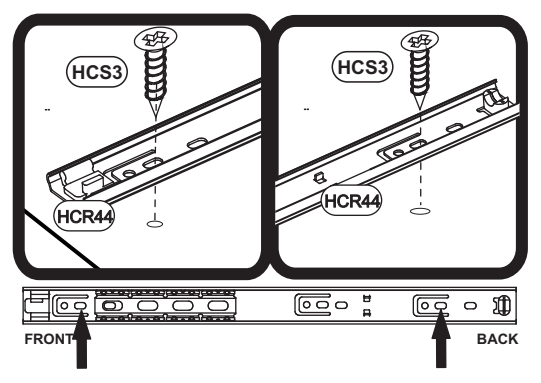
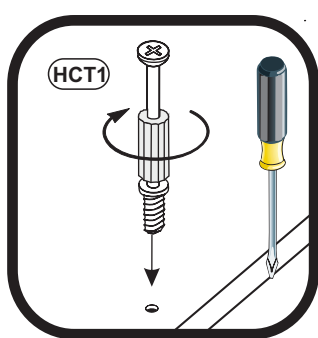
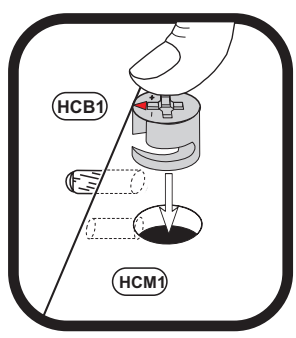
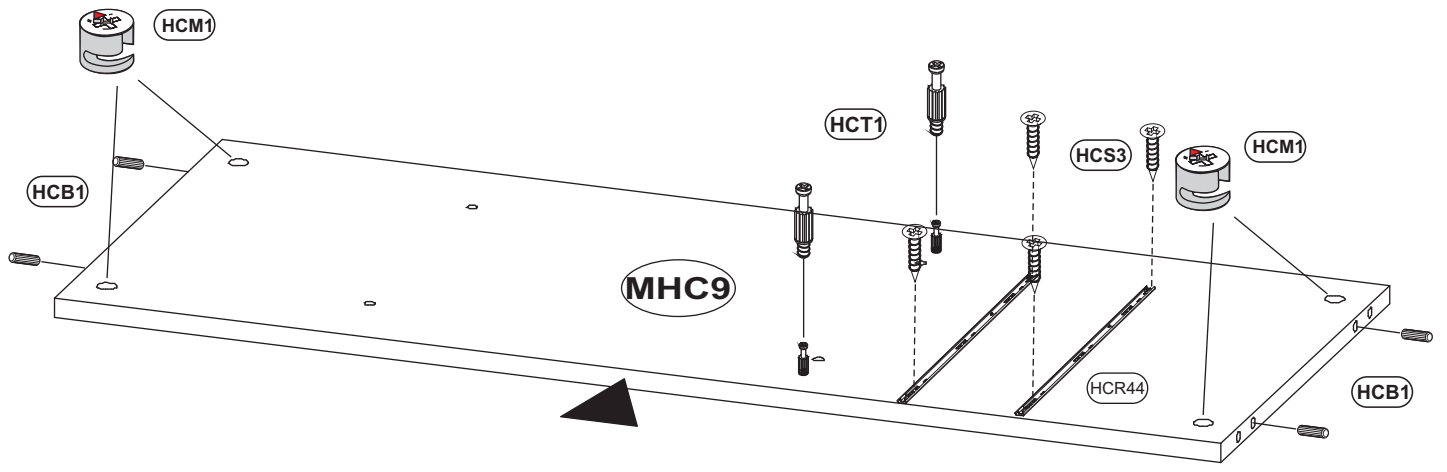
| | | |
|-------|-------|--------|
| HCR44 | | 123168 |
| | L-350 | x4 |



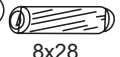
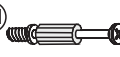

7

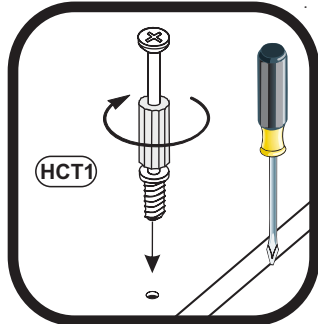
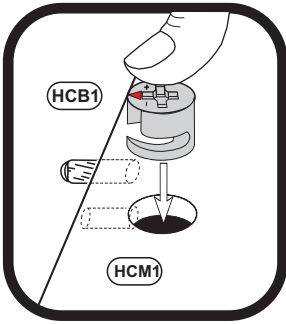
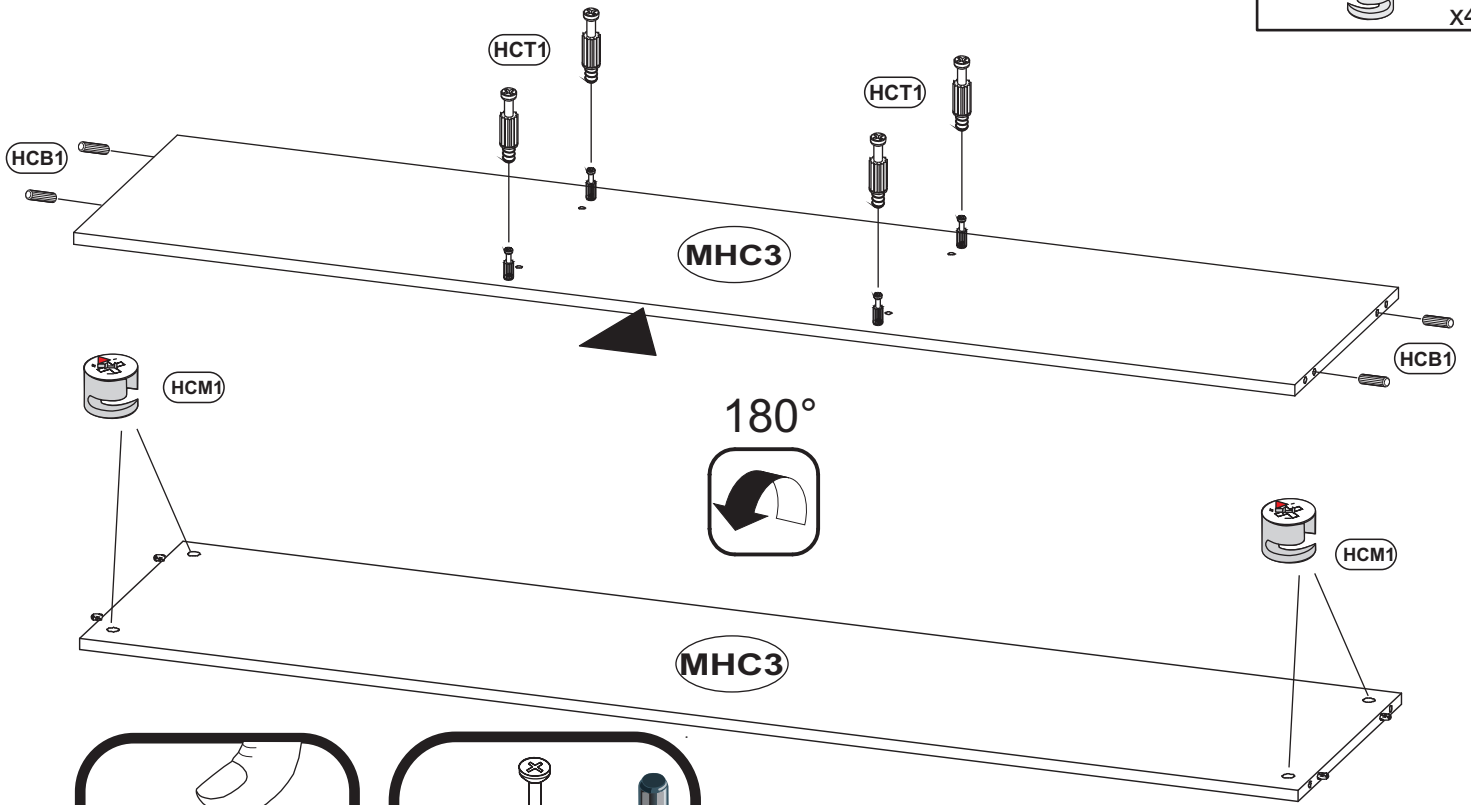
| | | |
|--------|---|--------|
| (HCB1) |  | 1018 |
| | 8x28 | x4 |
| (HCT1) |  | 11809 |
| | | x4 |
| (HCM1) |  | 123894 |
| | | x4 |

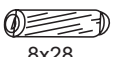

8

| | | |
|--------|---|--------|
| (HCB1) |  | 1018 |
| | 8x28 | x4 |
| (HCM1) |  | 123894 |
| | | x4 |

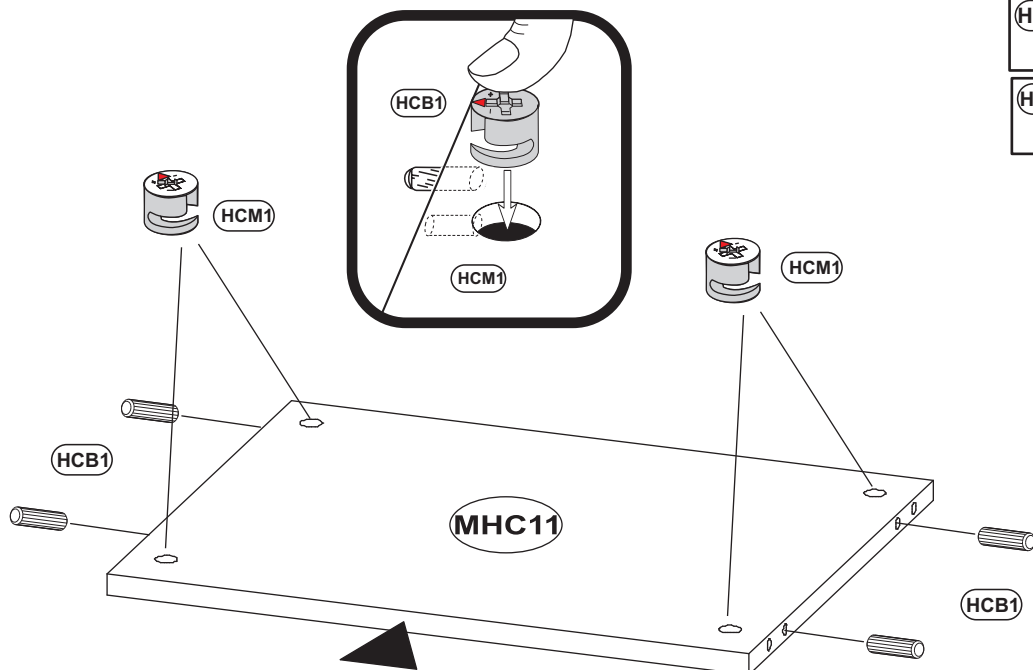

9

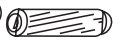
HC B1  1018
8x28 x4

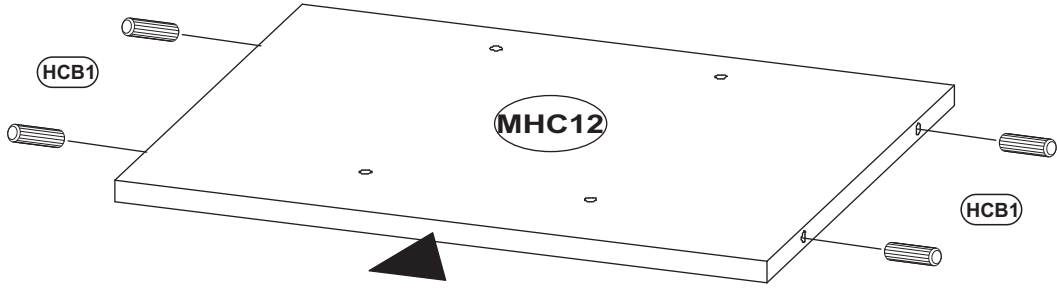

10

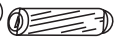
HC B1  1018
8x28 x8

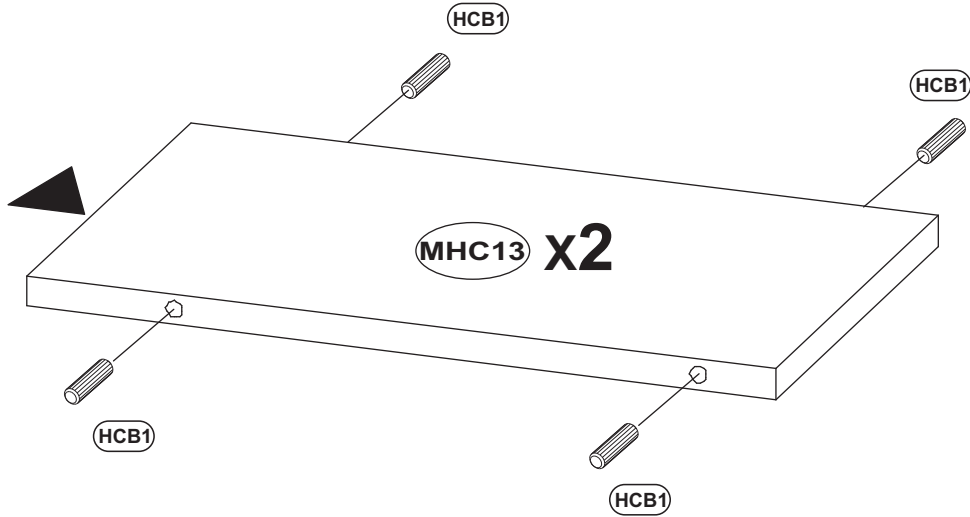

11

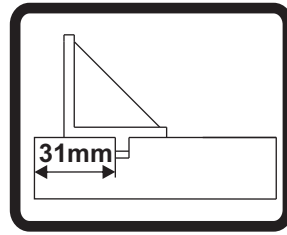
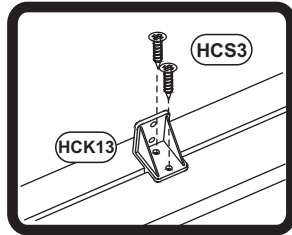

HCK13  23482
x8

HCS3  1011
3,5x13 x16

HCD14  23515
H4 x4

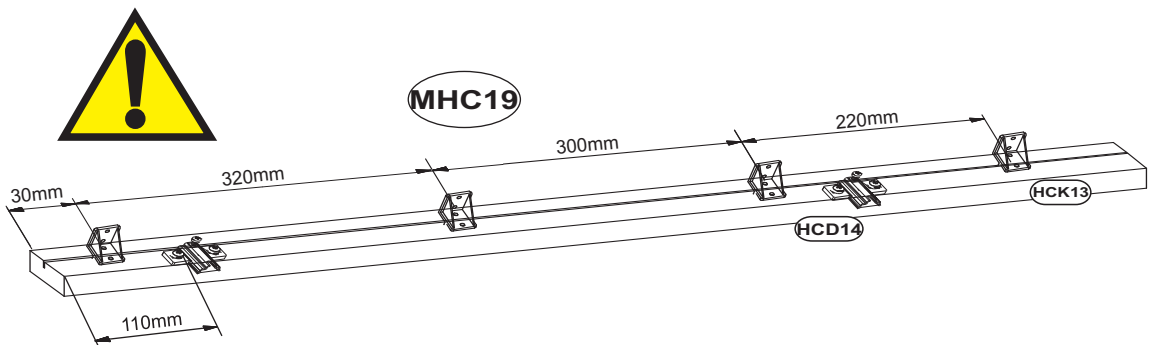
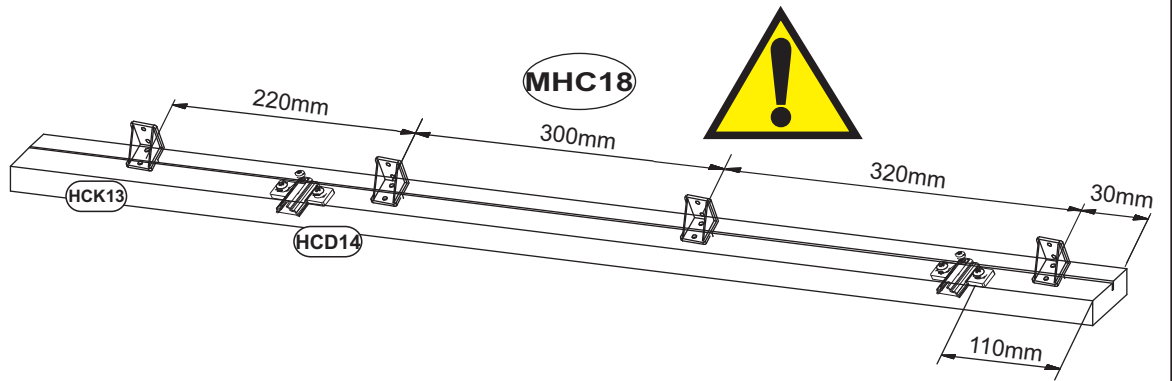
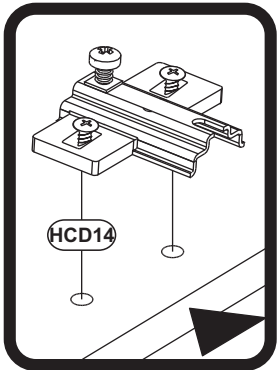

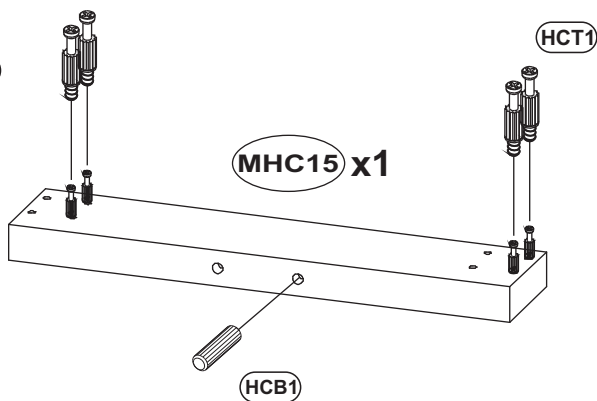
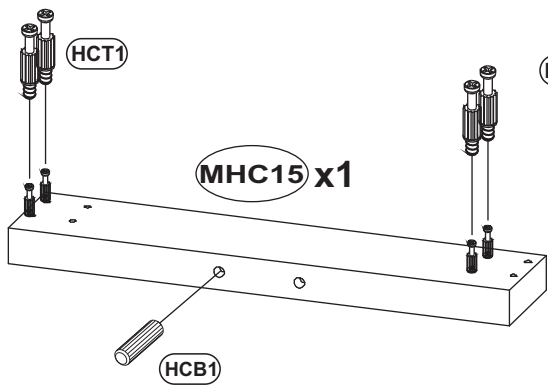
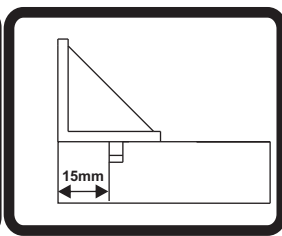
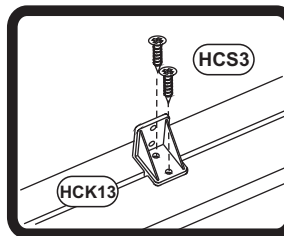
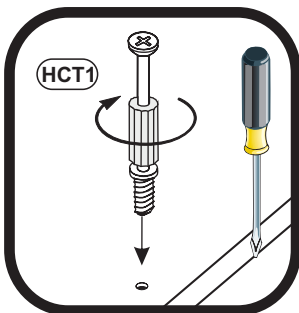
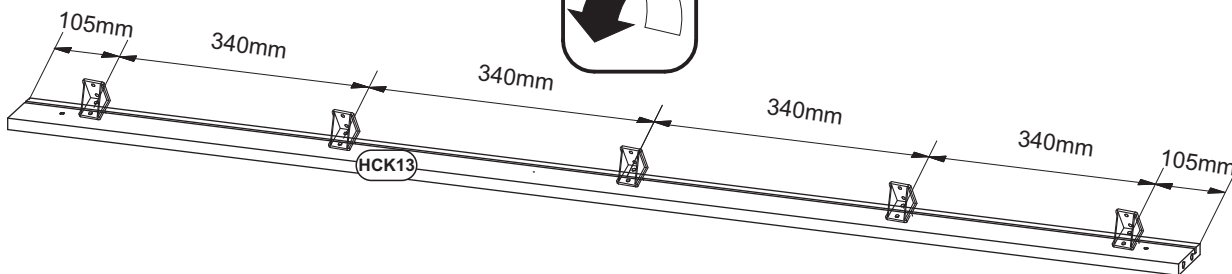
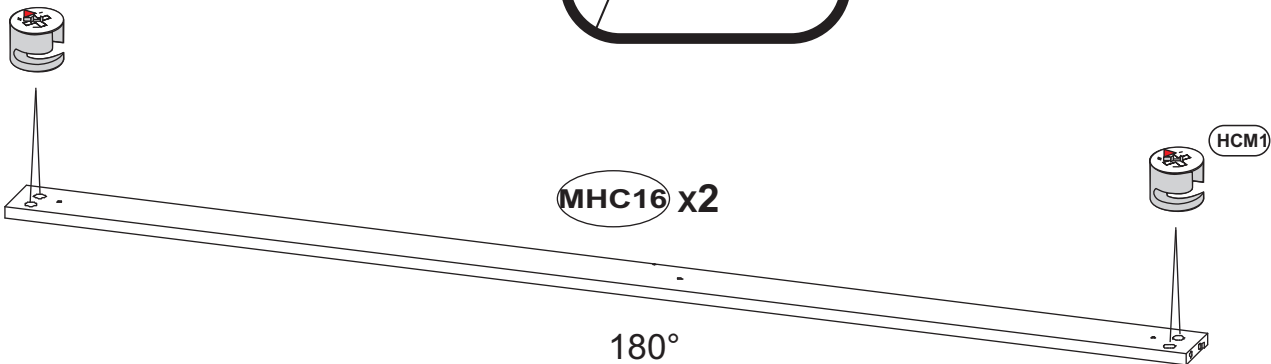
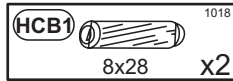
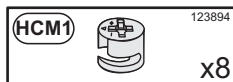
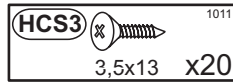
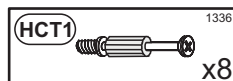
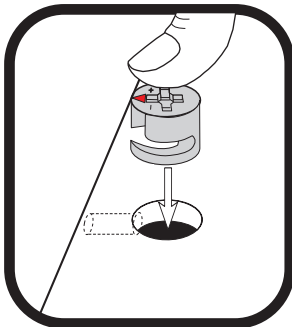

13

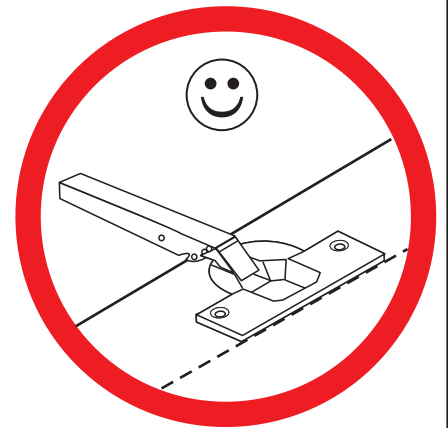
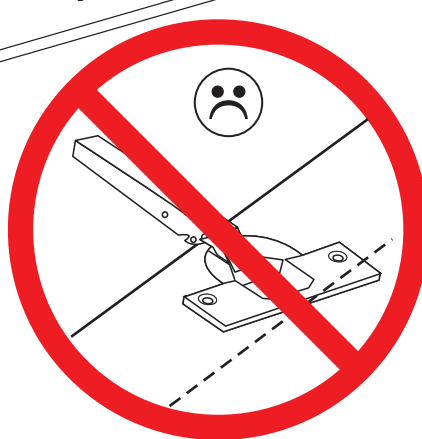
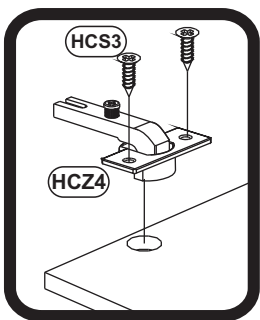
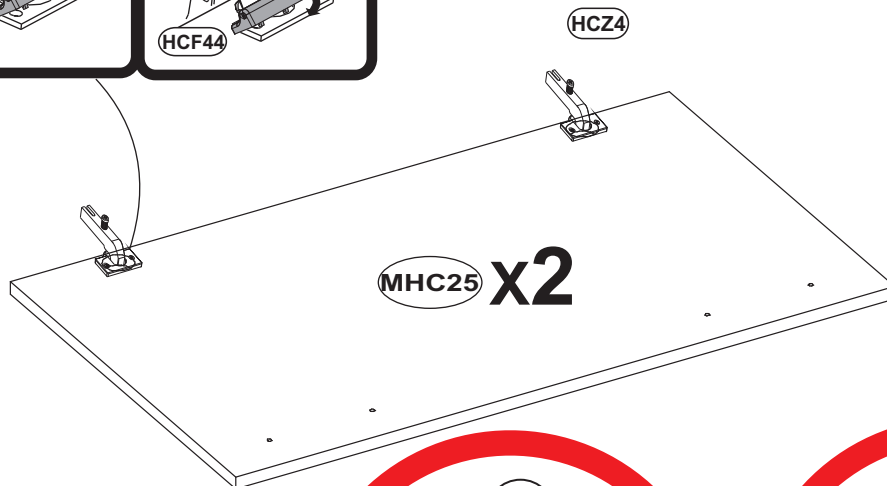
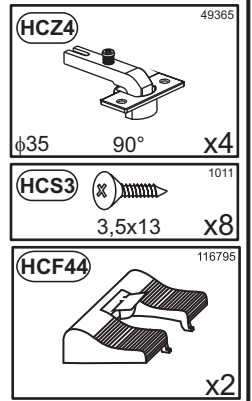
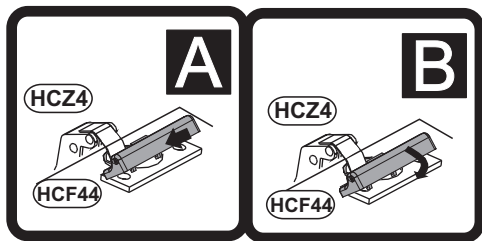

14

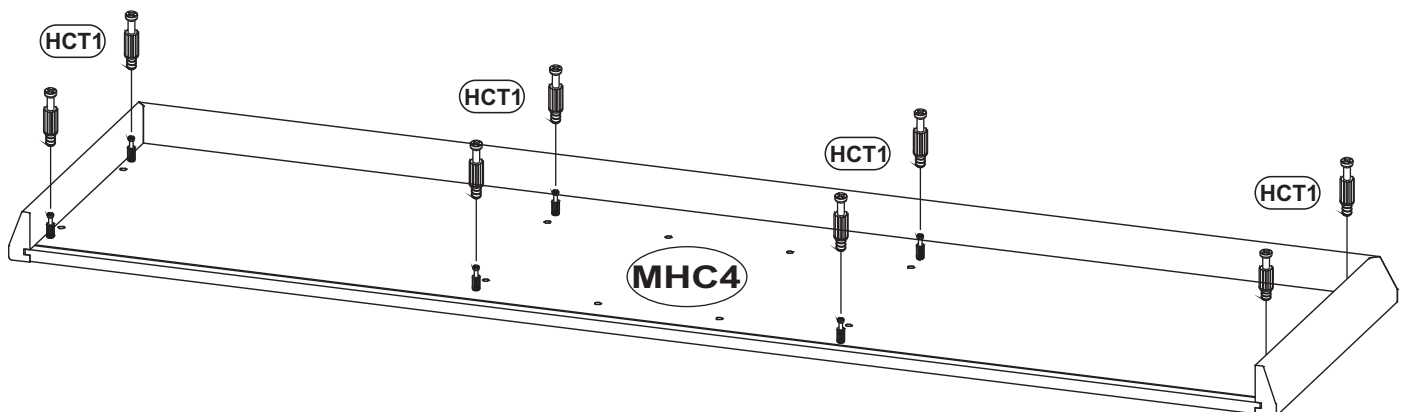
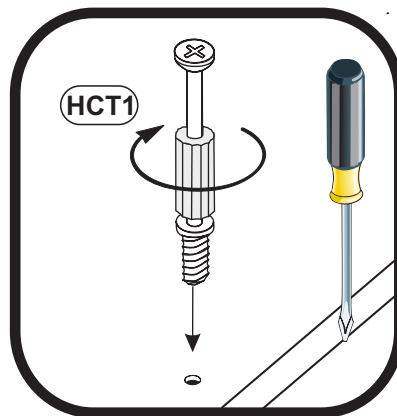
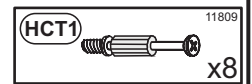

15

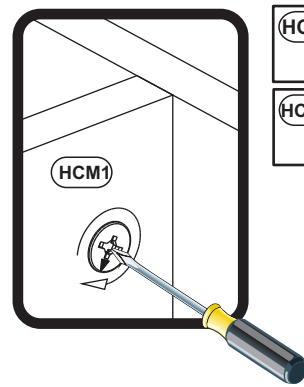
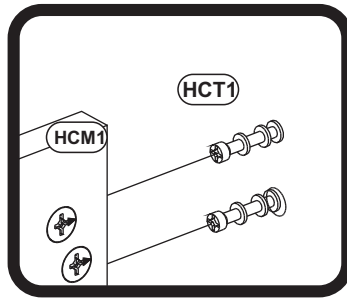

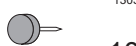
| | | |
|-------|---|------|
| HCP13 |  | 1012 |
| | 4x30 | x3 |
| HCF36 |  | 1305 |
| | | x10 |

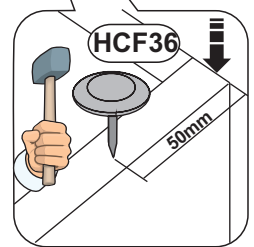
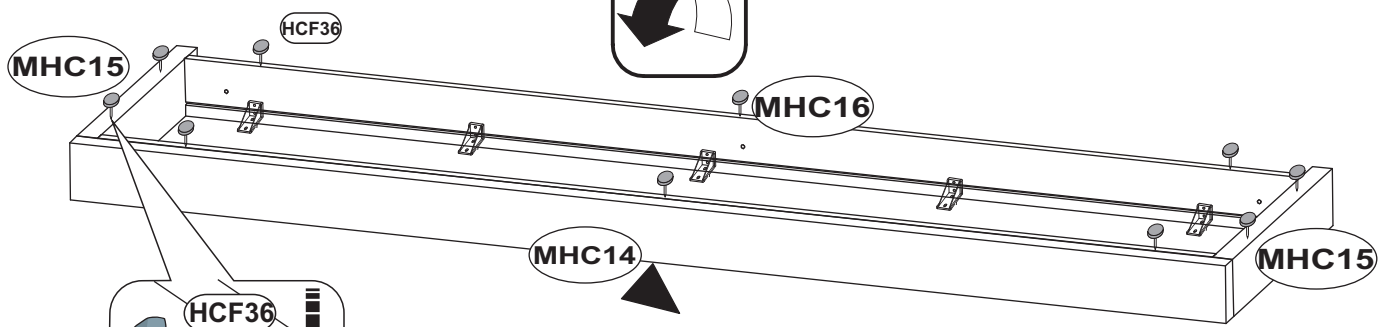
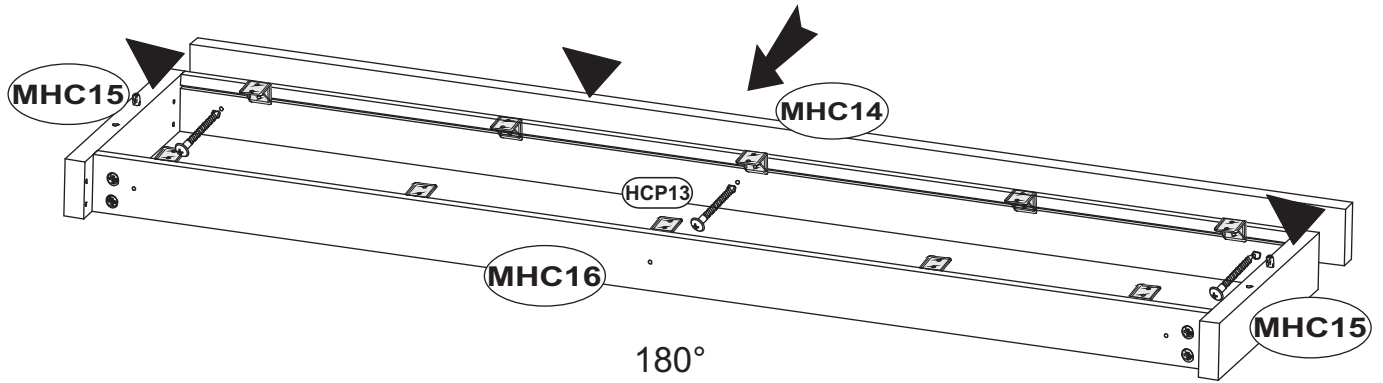
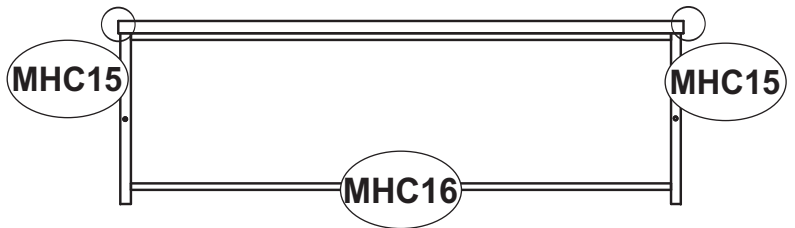
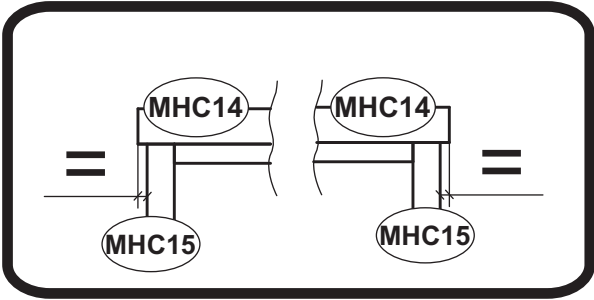
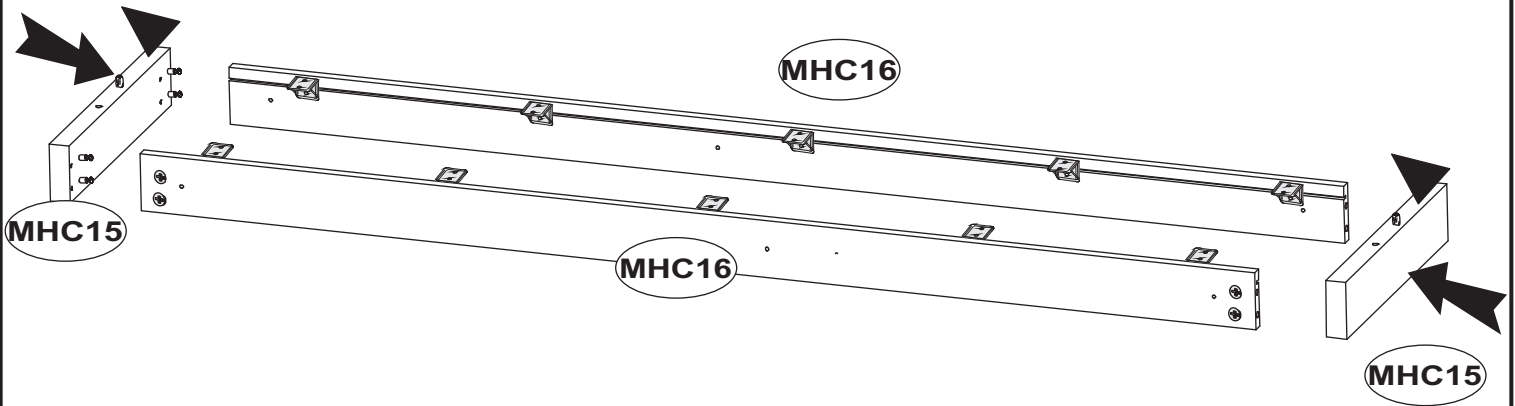

16

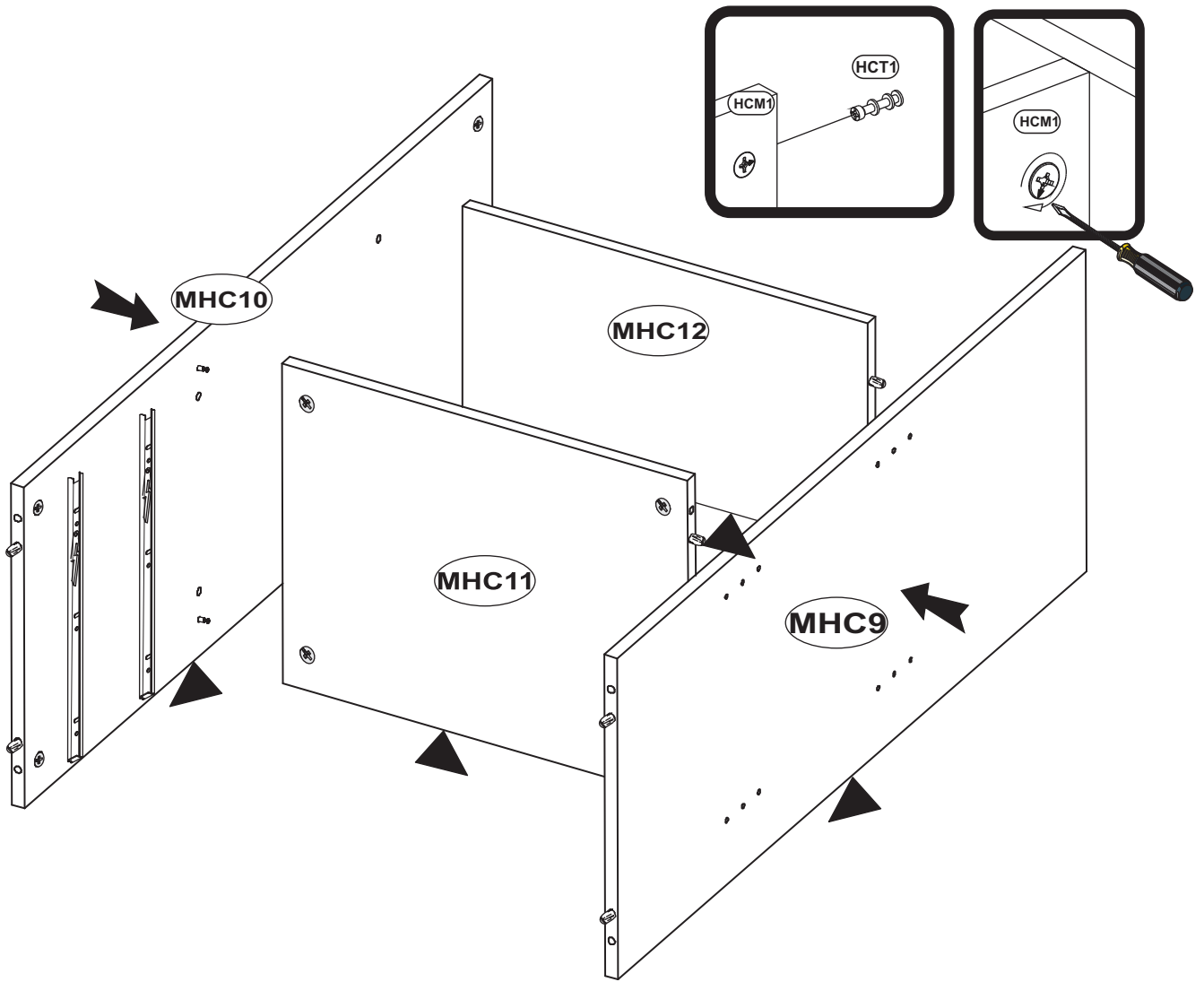

17

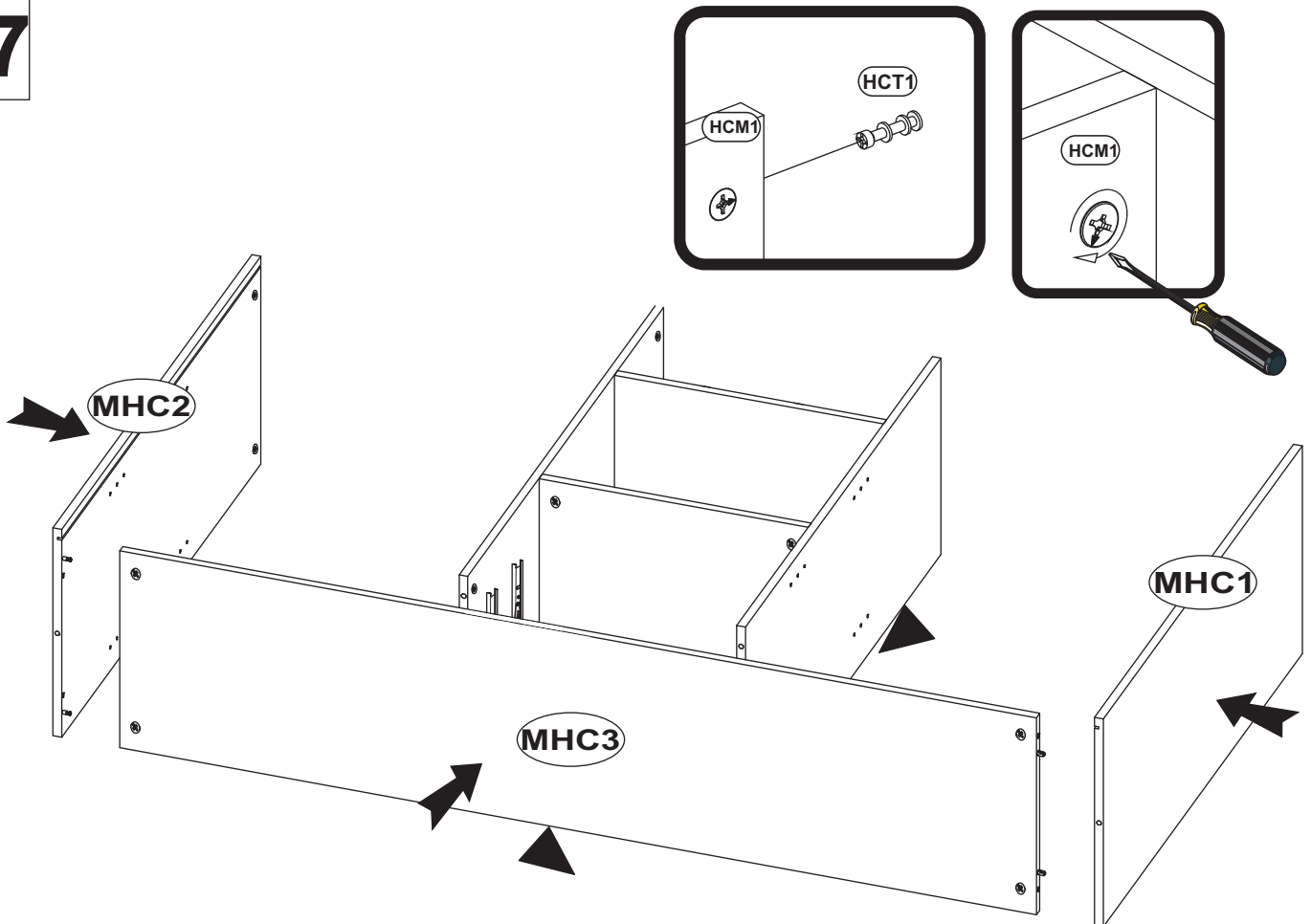



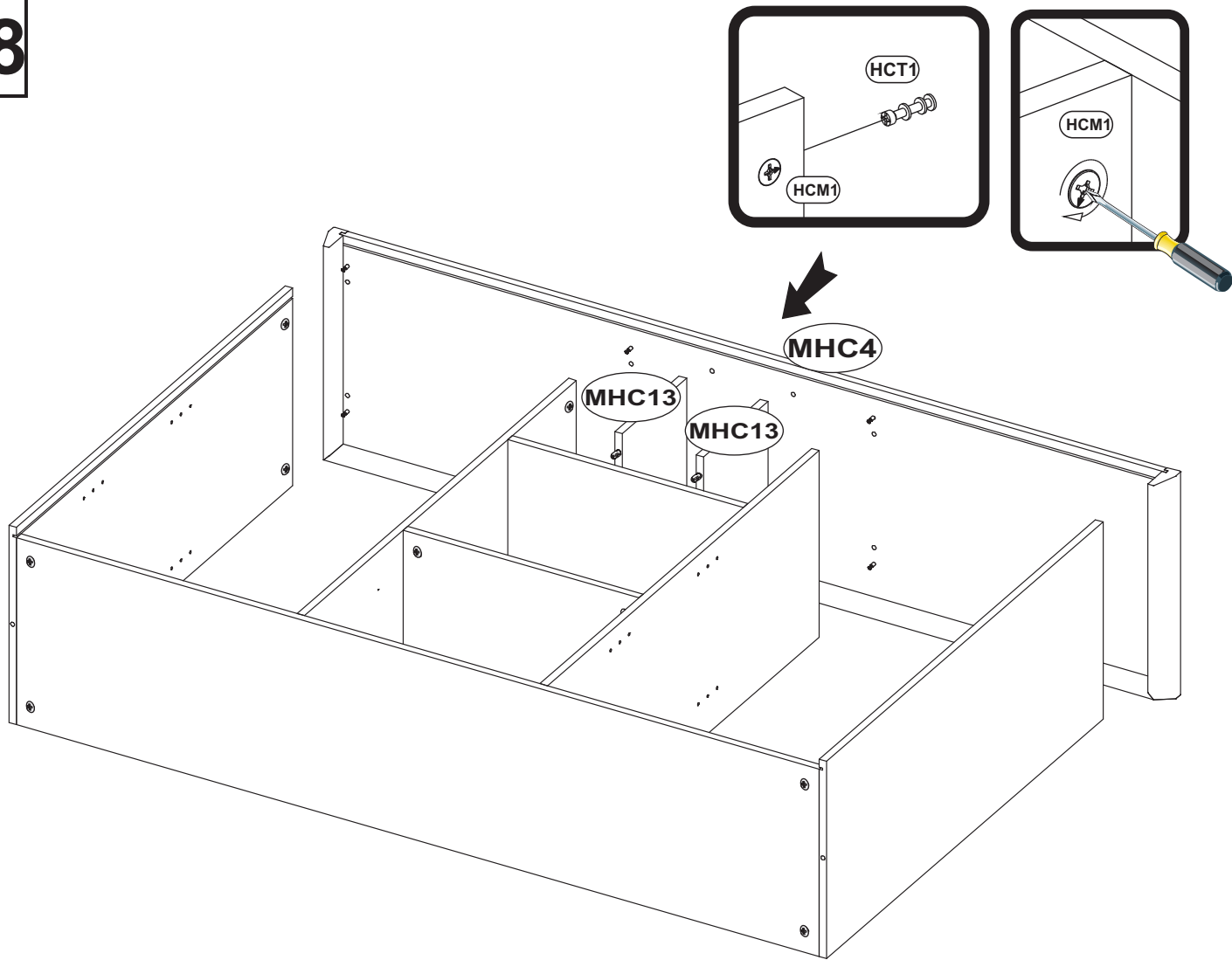

18

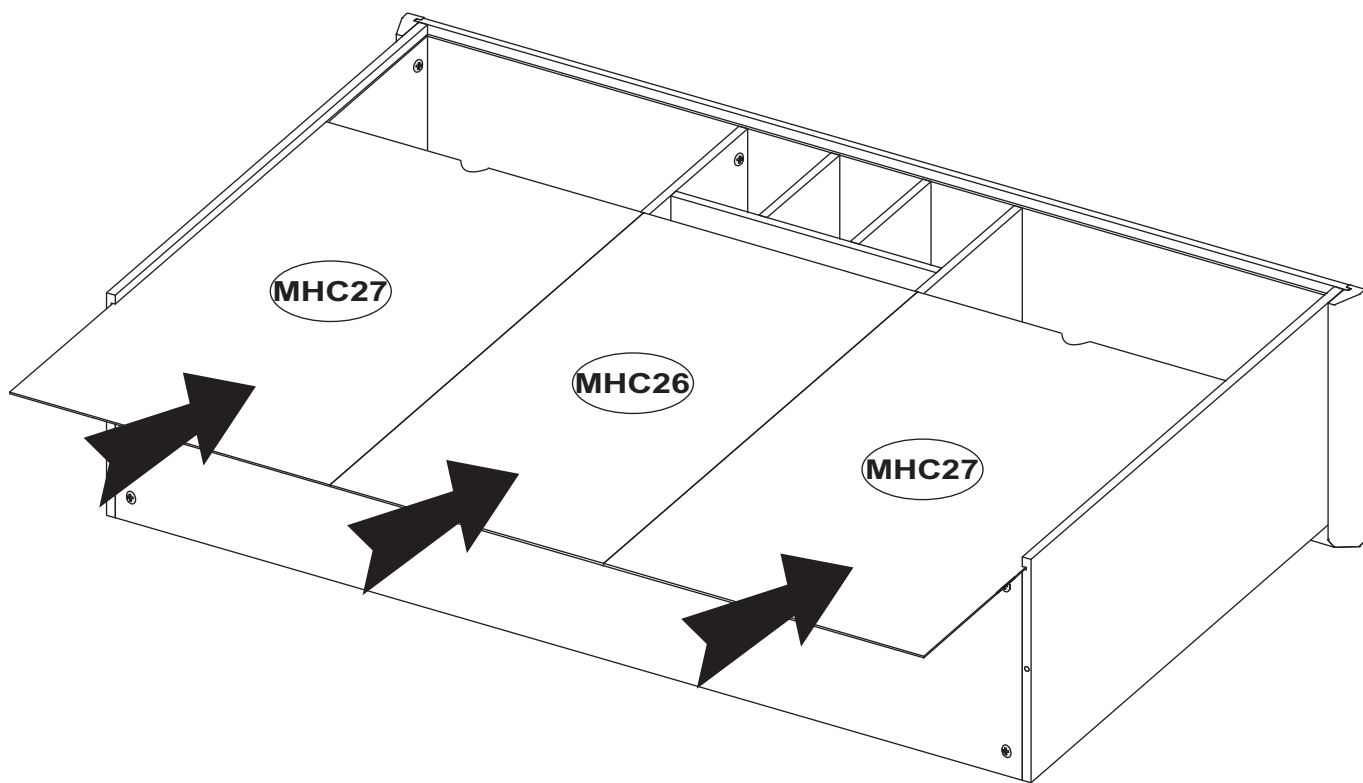

19



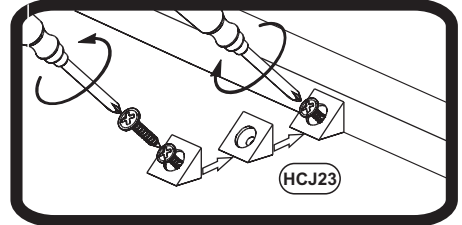
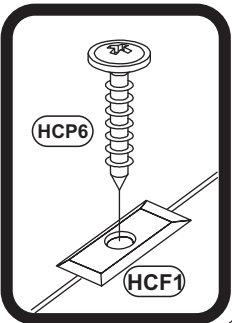
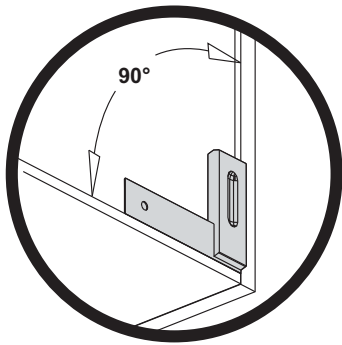

| | | |
|-------|---|------|
| HCJ23 |  | 1302 |
| | | x12 |
| HCP6 |  | 1056 |
| | 3x20 | x20 |
| HCF1 |  | 1415 |
| | | x10 |
| HCS3 |  | 1011 |
| | 3,5x13 | x20 |



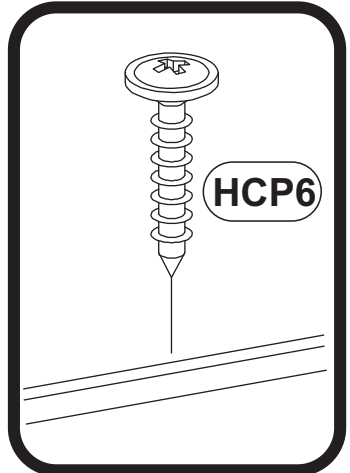
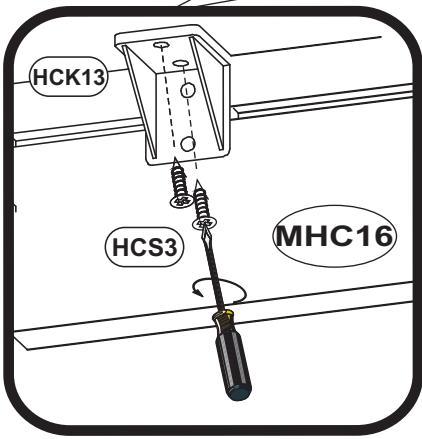
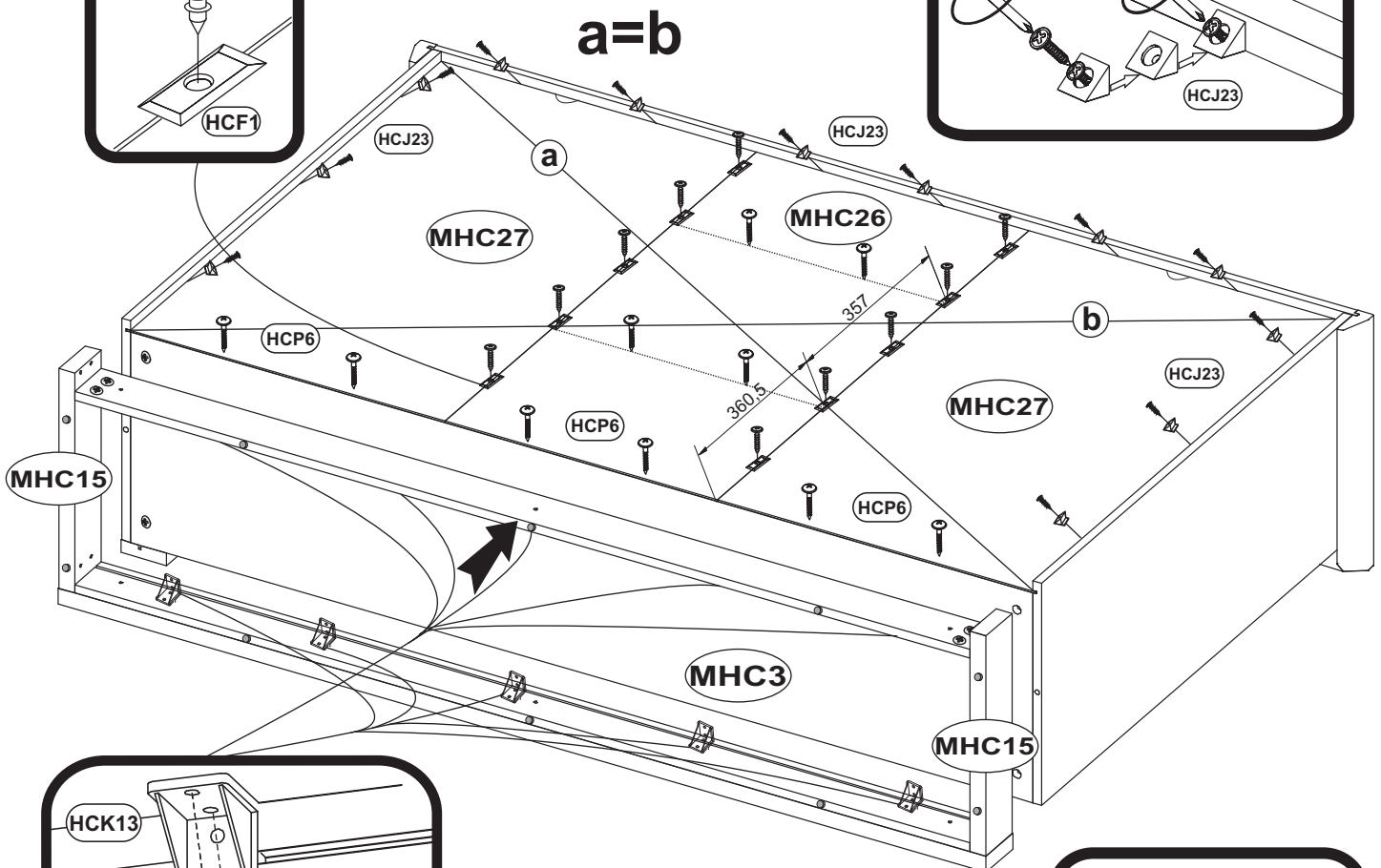

a=b

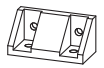

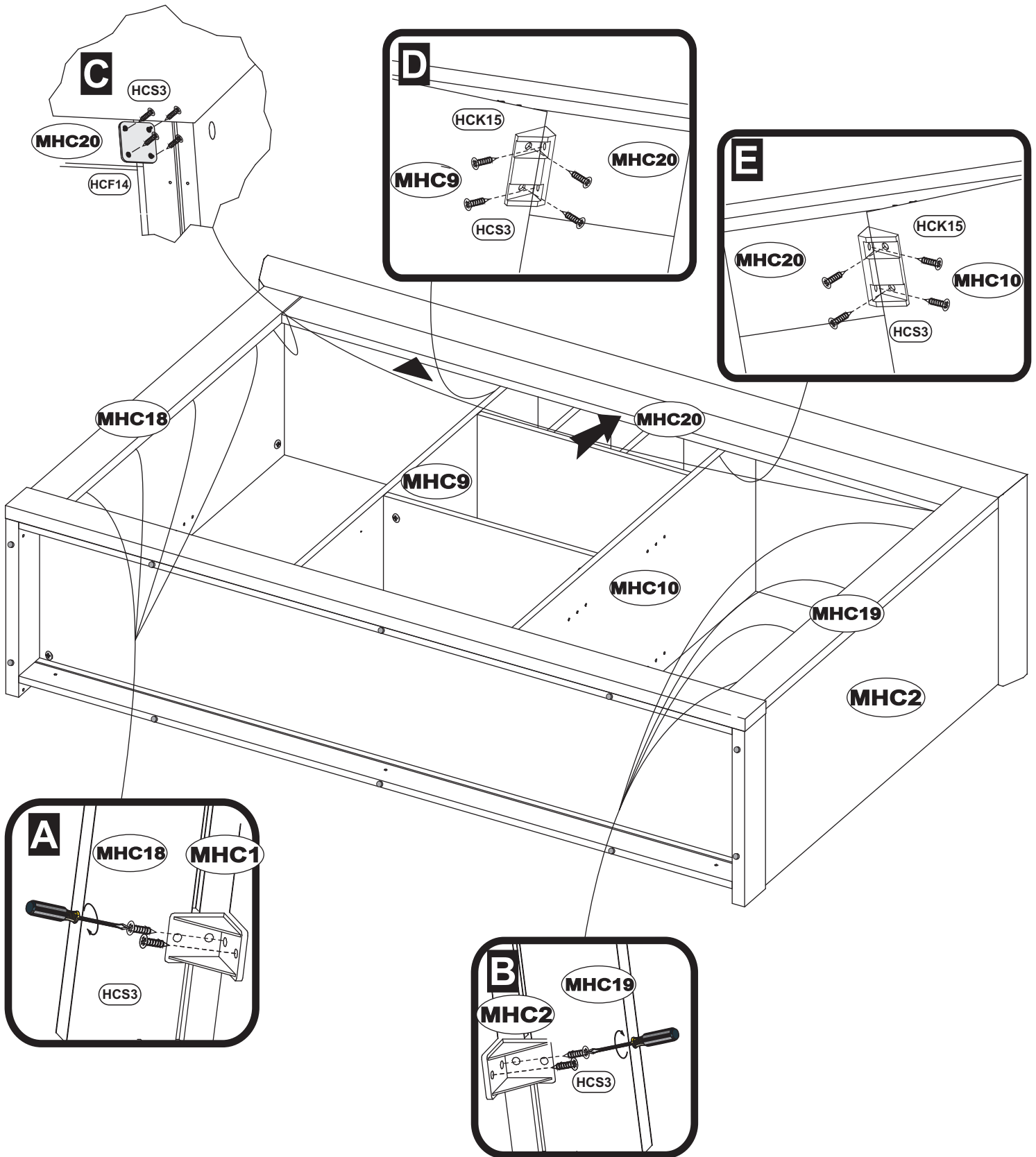
| | | |
|-------|---|-------|
| HCF14 |  | 1021 |
| | | x2 |
| HCS3 |  | 1011 |
| | 3.5x13 | x32 |
| HCK15 |  | 81556 |
| | | x2 |

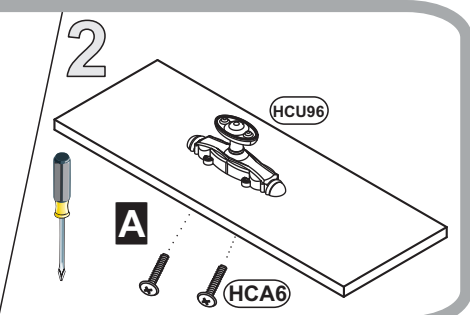
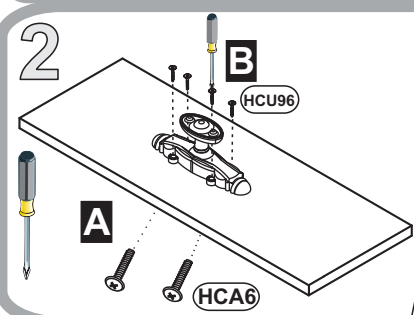
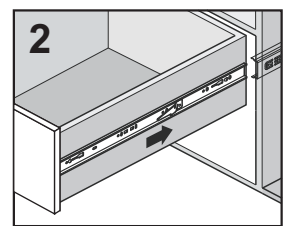
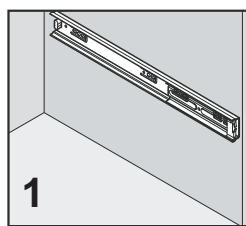
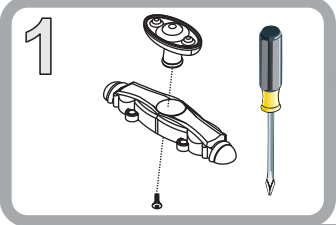
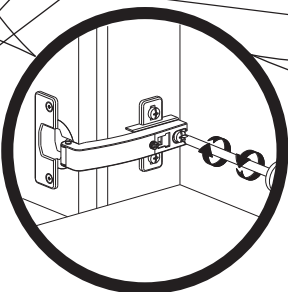
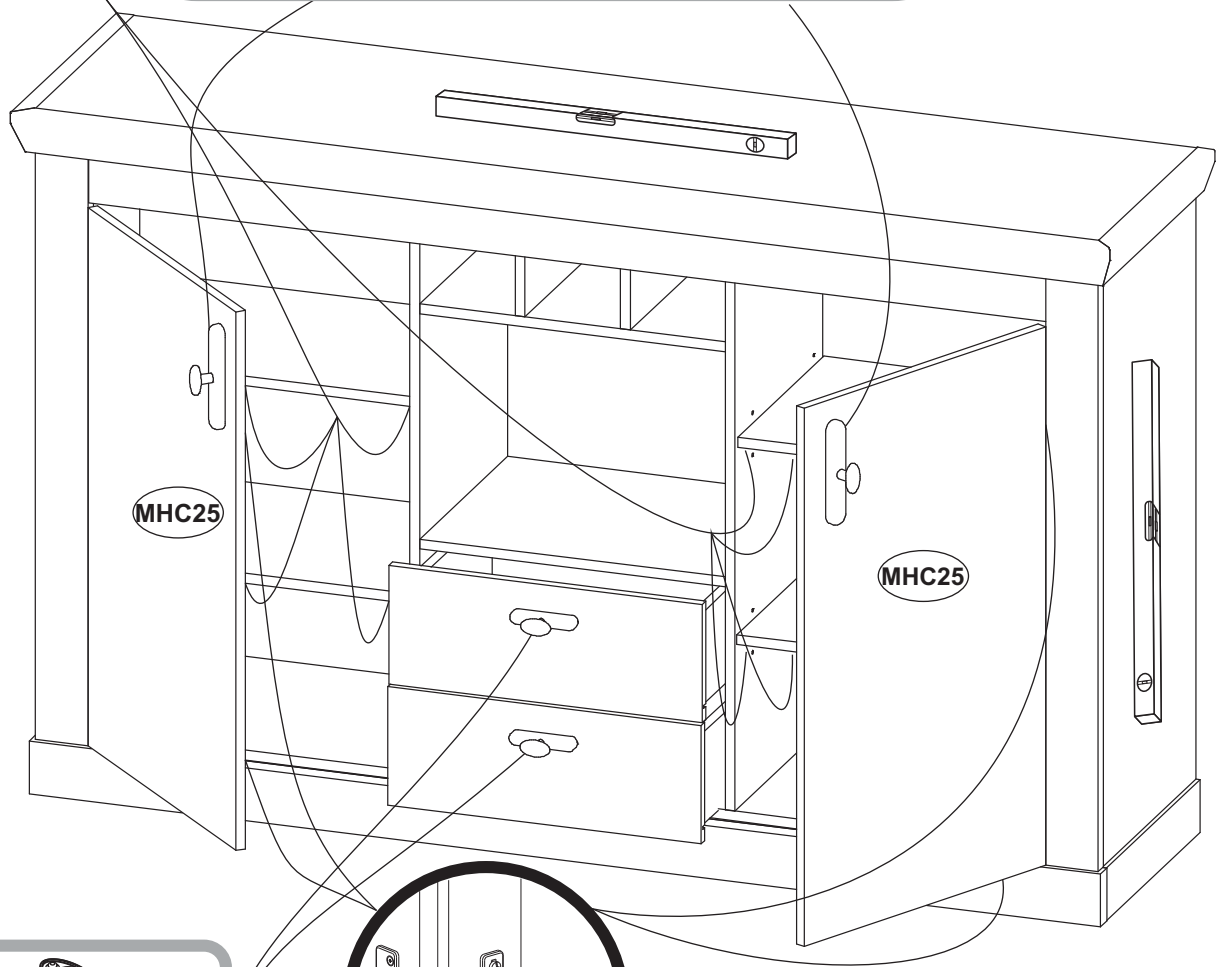
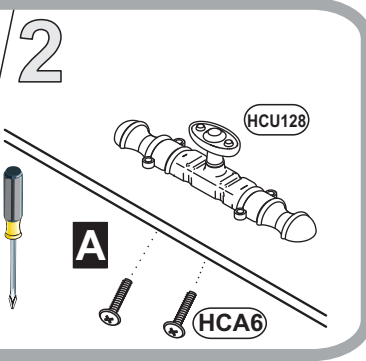
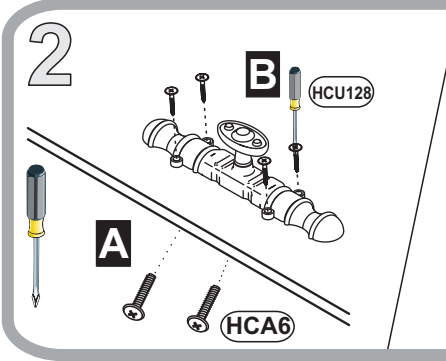
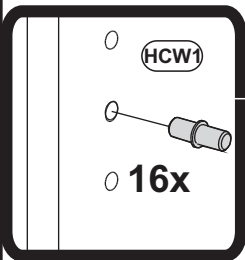
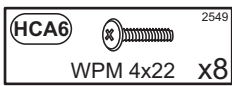
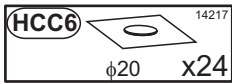
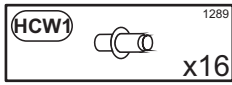
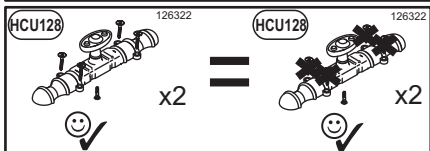
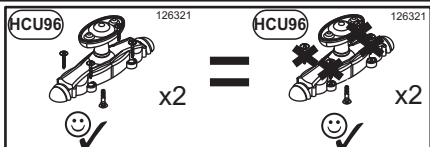
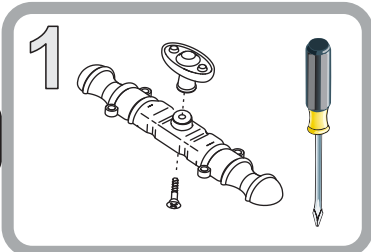
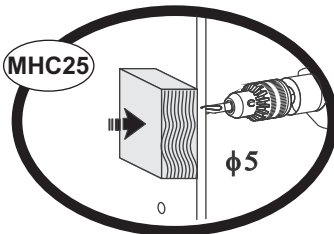

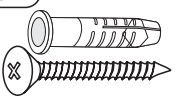

- HCJ11** 1267  x1
- HCP2** 1267  3,5x13 x2
- HCT17** 1267  x1

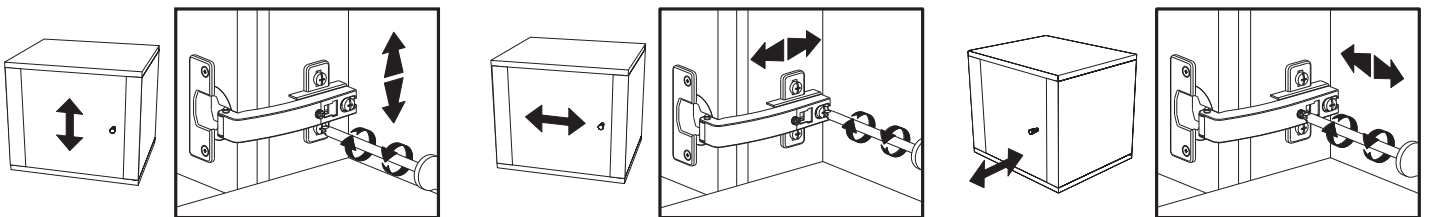
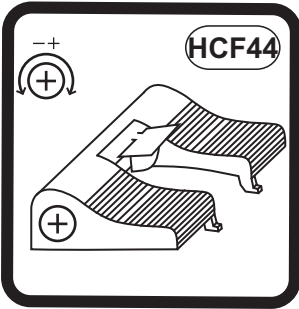
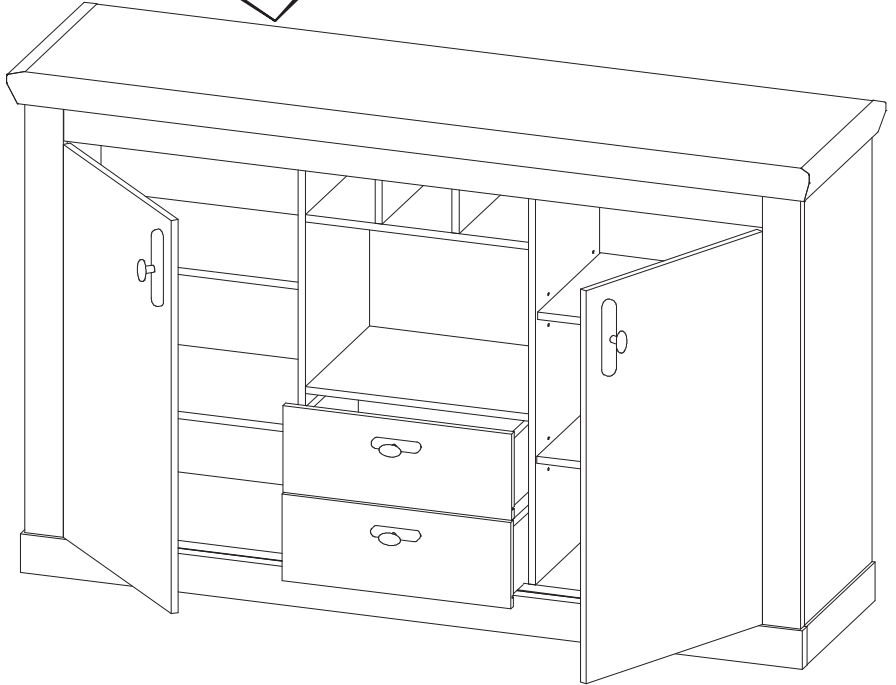
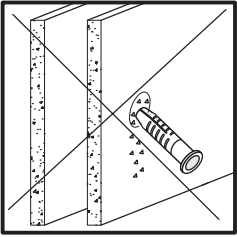
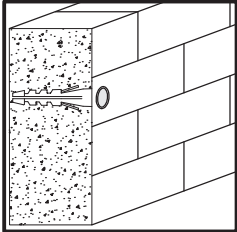
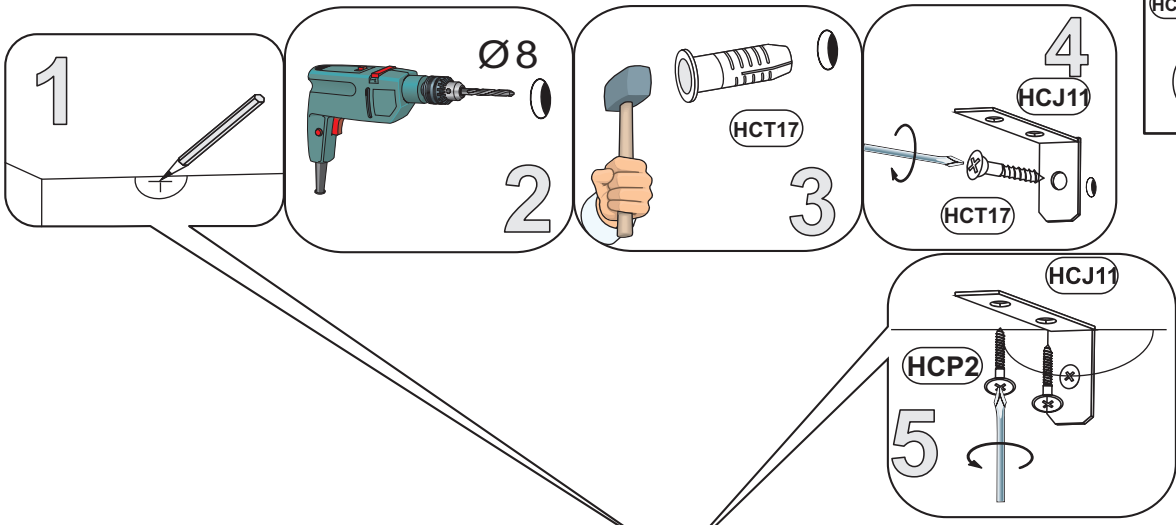

FLORENZ 51M

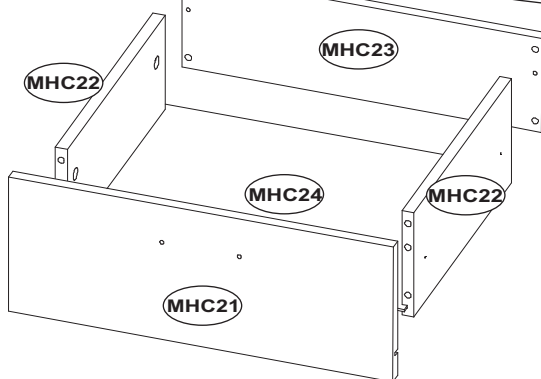
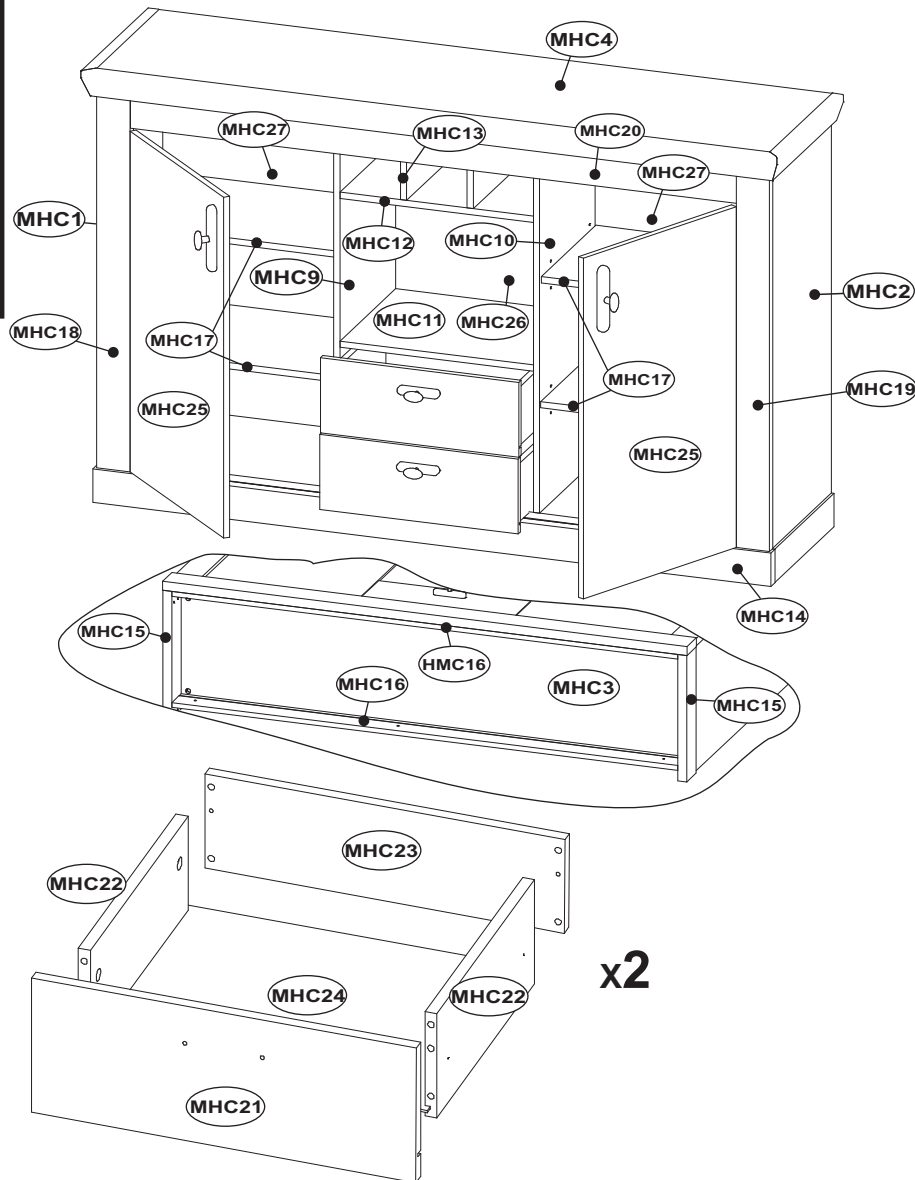
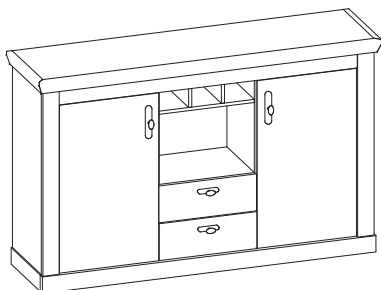

x2

D Unser Direktservice für Beschlagteile
Sollte Ihnen ein Beschlagteil fehlen, können Sie diese Servicekarte direkt an die untenstehende Adresse mailen. Wir können allerdings nur Beschlagteile auf diesem Wege verschicken. Sollten Sie eine andere Beanstandung an Ihrem Möbelstück haben, so wenden Sie sich bitte direkt an Ihr Möbelhaus.

GB Our direct order service for fitting
If a fitting part is missing, you can e-mail this service card directly to the address below. However, we can only send fitting parts in this way. If you have any other cause for complaint concerning your item of furniture, please contact your furniture store directly.

CZ Naše přímé služby pro kování
Chybí-li vám nějaký díl z kování, můžete tuto servisní kartu odeslat e-mailem přímo na níže uvedenou adresu. Touto cestou však můžeme zoslat jen díly kování. Pokud byste reklamovali jiný díl nábytku, obraťte se přímo na svého prodejce nábytku.

F Bien étudier la notice de montage
Si l'un des éléments de montage est manquant, veuillez envoyer directement la présente carte service à l'adresse e-mail indiquée ci-dessous. Cependant, ceci nous permet uniquement d'envoyer des ferrures. Pour tout autre type de réclamation concernant votre meuble, veuillez contacter directement votre magasin d'ameublement.

I Il nostro servizio diretto per l'ordine della ferramenta
Qualora Vi dovesse mancare un pezzo di fissaggio, allora Vi preghiamo di inviare questa carta di servizio immediatamente all'indirizzo sottostante. Possiamo inviare i pezzi di fissaggio solamente per mezzo di questo procedimento. Qualora dovreste avere qualche altra reclamazione in merito al mobile, allora Vi preghiamo di rivolgervi direttamente al Vostro Negozio di mobili.

BG Нашата директна услуга за обковок
Ако липсват части от комплекта, попълнете настоящата сервисна карта и ни я изпратете на e-mail адреса, посочен по-долу. По този начин можем да доставим само липсващи елементи от обковок. Ако установите други дефекти по мебелите, Ви съветваме да се обвърнете към мебелната къща/магазин, от който сте закупили стоката.

NL Onze directservice voor losse onderdelen
Wanneer er een onderdeel ontbreekt, kunt u deze servicekaart direct aan onderstaand e-mailadres sturen. Wij kunnen langs deze weg echter alleen beslagdelen versturen. Mocht u een ander probleem aan uw meubel hebben, verzoeken wij u contact op te nemen met uw meubeldealer.

PL Nasz bezpośredni serwis części montażowych
Jeżeli brakuje części koniecznych do montażu, prosimy o przesłanie nam niniejszej karty serwisowej na niżej podany adres e-mailowy. W ten sposób możemy przelać Państwu tylko brakujące części. W przypadku innych reklamacji dotyczących mebla, prosimy zgłosić się do salonu meblowego, w którym został dokonany zakup.

HR Servis za okove
U slučaju da nedostaje neki od dijelova molimo vas da na dolje navedenu mail adresu pošaljete ovaj servisni obrazac. Na ovaj način mogu se dostaviti samo okovi. U slučaju da imate dodatne prigovore vezane uz komad namještaja molimo vas da se obratite izravno trgovini namještaja gdje je isti kupljen.

HU Direktszolgáltatunk vasalattal esetén
Ha hiányzik egy vasalat, ézi a kártyát közvetlenül elküldheti az alább található címre. Azonban csak vasalattokat tudunk így küldeni. Amennyiben másfajta reklamáció áll fenn bütördarabját illetően, forduljon közvetlenül a bútortárházhoz.

SK Naš priamy servis pre časti kovania
Ak by Vám chýbala nejaká časť kovania, môžete poslať túto servisnú kartu poslať e-mailom na nižšie uvedenú adresu. Díly kovania vieme poslať iba týmto spôsobom. Ak by ste mali inú reklamáciu ohľadom Vašho nábytku, obraťte sa priamo na Vašu predajňu nábytku.

SLO Naše direktno uslužne storitve za okovje
Če vam manjka kakšno okovje, lahko to servisno kartico pošljete po e-pošti direktno na spodnji naslov. Po tej poti vam lahko pošljemo samo okovje. Če želite reklamirati kakšen drug del pohištva, se obrnite neposredno na vašo trgovino pohištva.

RO Service-ul nostru direct pentru feronerie
În cazul în care vă lipsește o piesă de feronerie puteți să trimiteți direct acest card de service prin e-mail la adresa de mai jos. Noi nu putem expedia piese de feronerie decât pe această cale. Dacă aveți o altă reclamație referitoare la piesa de mobilier, atunci vă rugăm să vă adresați direct la magazinul dvs. de mobilier.

RUS Наш прямой сервис для поставок фурнитуры
Если окажется, что Вам не хватает того или иного элемента фурнитуры, Вы можете отправить сервисную карту по факсу непосредственно на нижеприведенный адрес электронной почты. Однако, таким образом мы можем переслать лишь фурнитуру. Если же у Вас возникнут иные претензии относительно приобретенной мебели, пожалуйста, обращайтесь непосредственно в организацию, осуществляющую продажу.

S Vår direktservice för beslagsdelar
Om du saknar en beslagsdel kan du skicka detta servicekort direkt till e-postadressen som anges nedan. Tänk på att detta är den enda möjligheten att skicka beslagsdelar till dig. Om du vill reklamera din möbel av en annan anledning än kontakta ditt möbelfrit direkt.

ES Nuestro servicio directo para accesorios
Si le falta algún accesorio, puede enviar esta tarjeta de servicio directamente a la siguiente dirección. No obstante, por este método solo podemos enviar accesorios. Si tiene alguna otra objeción sobre su mueble, consulte directamente con su mueblería.

TR Donatılar için doğrudan servisimiz
Bir donatınız eksikse bu servis kartını doğrudan aşağıda bulunan adrese doğrudan mail yazabilirsiniz. Sadece bu yolla donatıları gönderebiliriz. Mobilyanızda başka şikayetleriniz varsa lütfen doğrudan mobilya satıcınıza danışın.

| | | | | | | | | | |
|-------|------|-------|----|-----|-------|------|-----|----|-----|
| MHC1 | 944 | 389 | 15 | 1/2 | MHC17 | 543 | 360 | 15 | 2/2 |
| MHC2 | 944 | 389 | 15 | 1/2 | MHC18 | 944 | 80 | 22 | 1/2 |
| MHC3 | 1583 | 369 | 15 | 2/2 | MHC19 | 944 | 80 | 22 | 1/2 |
| MHC4 | 1671 | 439,5 | 65 | 1/2 | MHC20 | 1455 | 120 | 18 | 2/2 |
| MHC9 | 929 | 368 | 15 | 2/2 | MHC21 | 477 | 180 | 15 | 1/2 |
| MHC10 | 929 | 368 | 15 | 2/2 | MHC22 | 332 | 140 | 15 | 1/2 |
| MHC11 | 464 | 367 | 15 | 2/2 | MHC23 | 445 | 126 | 15 | 1/2 |
| MHC12 | 464 | 367 | 15 | 2/2 | MHC24 | 426 | 354 | 3 | 1/2 |
| MHC13 | 219 | 366 | 15 | 1/2 | MHC25 | 818 | 484 | 15 | 1/2 |
| MHC14 | 1627 | 80 | 28 | 2/2 | MHC26 | 949 | 478 | 3 | 2/2 |
| MHC15 | 386 | 80 | 28 | 2/2 | MHC27 | 949 | 558 | 3 | 2/2 |
| MHC16 | 1570 | 80 | 15 | 2/2 | | | | | |

FLORENZ 51M

D

Unser Direktservice für Beschlagteile

Sollte Ihnen ein Beschlagteil fehlen, können Sie diese Servicekarte direkt an die untenstehende Adresse mailen. Wir können allerdings nur Beschlagteile auf diesem Wege verschicken. Sollten Sie eine andere Beanstandung an Ihrem Möbelstück haben, so wenden sie sich bitte direkt an Ihr Möbelhaus.

GB

Our direct order service for fitting

If a fitting part is missing, you can e-mail this service card directly to the address below. However, we can only send fitting parts in this way. If you have any other cause for complaint concerning your item of furniture, please contact your furniture store directly.

CZ

Náše přímé služby pro kování

Chybí-li vám nějaký díl z kování, můžete tuto servisní kartu odeslat e-mailem přímo na níže uvedenou adresu. Touto cestou však můžeme rozesílat jen díly kování. Pokud byste reklamovali jiný díl nábytku, obraťte se přímo na svého prodejce nábytku.

F

Bien étudier la notice de montage

Si l'un des éléments de montage manque, vous pouvez envoyer directement la présente carte de service à l'adresse e-mail indiquée ci-dessous. Cependant, ceci nous permet uniquement d'envoyer des ferrures. Pour tout autre type de réclamation concernant votre meuble, veuillez contacter directement votre magasin d'ameublement.

I

Il nostro servizio diretto per l'ordine della ferramenta

Qualora Vi dovesse mancare un pezzo di fissaggio, allora Vi preghiamo di inviare questa carta di servizio immediatamente all'indirizzo sottostante. Possiamo inviare i pezzi di fissaggio solamente per mezzo di questo procedimento. Qualora dovete avere qualche altra reclamazione in merito al mobile, allora Vi preghiamo di rivolgerVi direttamente al Vostro Negozio di mobili.

Нашата директна услуга за обкоя

Ако липсват части от комплекта, потърнете настоящата сервисна карта и ни я изпратете на e-mail адрес, посочен по-долу. По този начин можем да доставяме само липсващи елементи от обкоя. Ако установите други дефекти по мебелите, Ви съветваме да се обърнете към мебелната къща/магазин, от който сте закупили стоката.

BG

Onze directservice voor losse onderdelen

Wanneer er een onderdeel ontbreekt, kunt u deze servicekaart direct aan onderstaand e-mailadres sturen. Wij kunnen langs deze weg echter alleen bestelgedelen versturen. Mocht u een ander probleem aan uw meubel hebben, verzoeken wij u contact op te nemen met uw meubeldealer.

NL

Nasz bezpośredni serwis czeski montażowych

Jeżeli brakuje części koniecznych do montażu, prosimy o przesłanie nam niniejszej karty serwisowej na niżej podany adres e-mailowy. W ten sposób możemy przesyłać Państwu tylko brakujące części. W przypadku innych reklamacji dotyczących mebla, prosimy zgłosić się do salonu meblowego, w którym został dokonany zakup.

PL

Servis za okove

U slučaju da nedostaje neki od dijelova molimo vas da na dolje navedenu mail adresu pošaljete ovaj servisni obrazac. Na ovaj način mogu se dostaviti samo okovi. U slučaju da imate dodatne prigovore vezane uz komad namještaja molimo vas da se obratite izravno trgovini namještaja gdje je isti kupljen.

HR

Direktszolgáltatunk vasalatok esetén

Ha hiányzik egy vasalat, ezt a kártyát közvetlenül elküldheti az alább található címre. Azonban csakis vasalatoskat tudunk így küldeni. Amennyiben másfajta reklamáció áll fenn bútoráruháztól illetően, forduljon közvetlenül a bútoráruházhoz.

HU

Náš priamy servis pre časti kovania

Ak by Vám chýbala nejaká časť kovania, môžete poslať túto servisnú kartu pošťou e-mailom na nižšie uvedenú adresu. Díly kovania vieme poslať iba týmto spôsobom. Ak by ste mali inú reklamáciu ohľadom Vašho nábytku, obráťte sa priamo na Vašu predajňu nábytku.

SK

SLO

Náše direktne uslužne storitve za okovje
Ce vam manjka kakšno okovje, lahko to servisno kartico pošljete po e-pošti direktno na spodnji naslov. Po tej poti vam lahko pošljemo samo okovje. Če želite reklamirati kakšen drug del pohištva, se obrnite neposredno na vašo trgovino pohištva.

Service-ul nostru direct pentru feronerie

În cazul în care vă lipsește o piesă de feronerie puteți să trimiteți direct acest card de service prin e-mail la adresa de mai jos. Noi nu putem expedia piese de feronerie decât pe această cale. Dacă aveți o altă reclamație referitoare la piesa de mobilier, atunci vă rugăm să vă adresați direct la magazinul dvs. de mobilă.

RO

RUS

Наш прямой сервис для поставок фурнитуры
Если окажется, что Вам не хватает того или иного элемента фурнитуры, Вы можете отправить сервисную карту по факсу непосредственно на нижеприведенный адрес электронной почты. Однако, таким образом мы можем пересылать лишь фурнитуру. Если же у Вас возникнут иные претензии относительно приобретенной мебели, пожалуйста, обращайтесь непосредственно в организацию, осуществившую продажу.

Vår direktservice för beslagsdelar

Om du saknar en beslagsdel kan du skicka detta servicekort direkt till e-postadressen som anges nedan. Tänk på att detta är den enda möjligheten att skicka beslagsdelar till dig. Om du vill reklamera din möbel av en annan anledning måste du kontakta ditt möbelhus direkt.

S

ES











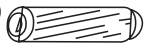
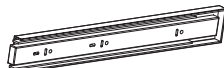





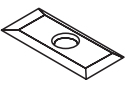

Nuestro servicio directo para accesorios

Si le falta algún accesorio, puede enviar esta tarjeta de servicio directamente a la siguiente dirección. No obstante, por este método solo podemos enviar accesorios. Si tiene alguna otra objeción sobre su mueble, consulte directamente con su mueblería.

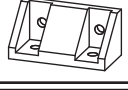
TR

Donatılar için doğrudan servisimiz

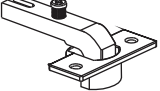
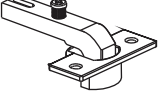
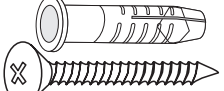
Bir donatınız eksikse bu servis kartını doğrudan aşağıda bulunan adrese doğrudan mail yazabilirsiniz. Sadece bu yolla donatıları gönderebiliriz. Mobilyanızda başka şikayetleriniz varsa lütfen doğrudan mobilya satıcınıza danışın.

| | | | | |
|---|--|--------|---|---|
| HCB1 8x28 X... 1018 |  | 123165 | HCR44 L-350 X... 123165 |  |
| HCM1 X... 123894 |  | 1011 | HCS3 3,5x13 X... 1011 |  |
| HCT1 X... 11809 |  | 1012 | HCP13 4x30 X... 1012 |  |
| HCJ23 X... 1302 |  | 1305 | HCF36 X... 1305 |  |
| HCC6 φ20 X... 00000 |  | 1021 | HCF14 X... 1021 |  |
| HCW1 X... 1289 |  | 2549 | HCA6 WPM 4x22 X... 2549 |  |
| HCF1 X... 1415 |  | 1267 | HCP2 3,5x13 X... 1267 |  |
| HCK15 X... 81556 |  | 116795 | HCF44 X... 116795 |  |
| HCJ11 X... 1267 |  | 49716 | HCK13 X... 49716 |  |
| HCK13 X... 49716 |  | 49365 | HCZ4 φ35 90° X... 49365 |  |
| HCZ4 φ35 90° X... 49365 |  | 1267 | HCT17 X... 1267 |  |
| HCD14 H4 X... 23515 |  | 1056 | HCP6 3x20 X... 1056 |  |

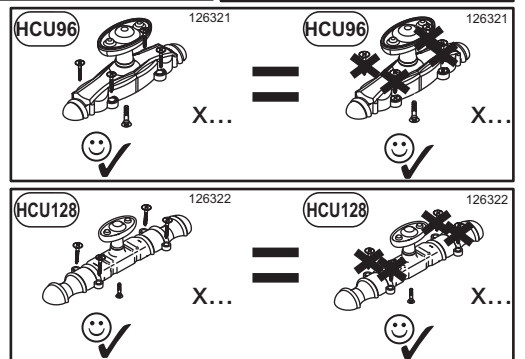
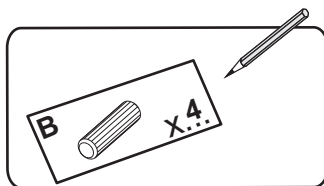

FLORENZ 71M

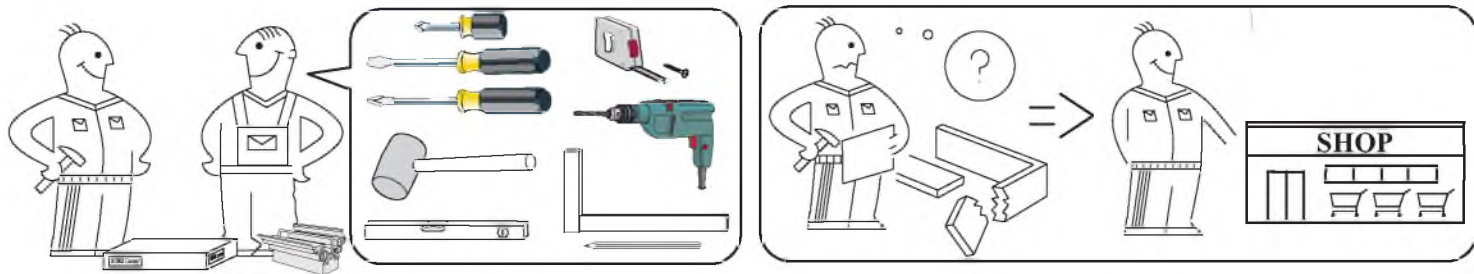
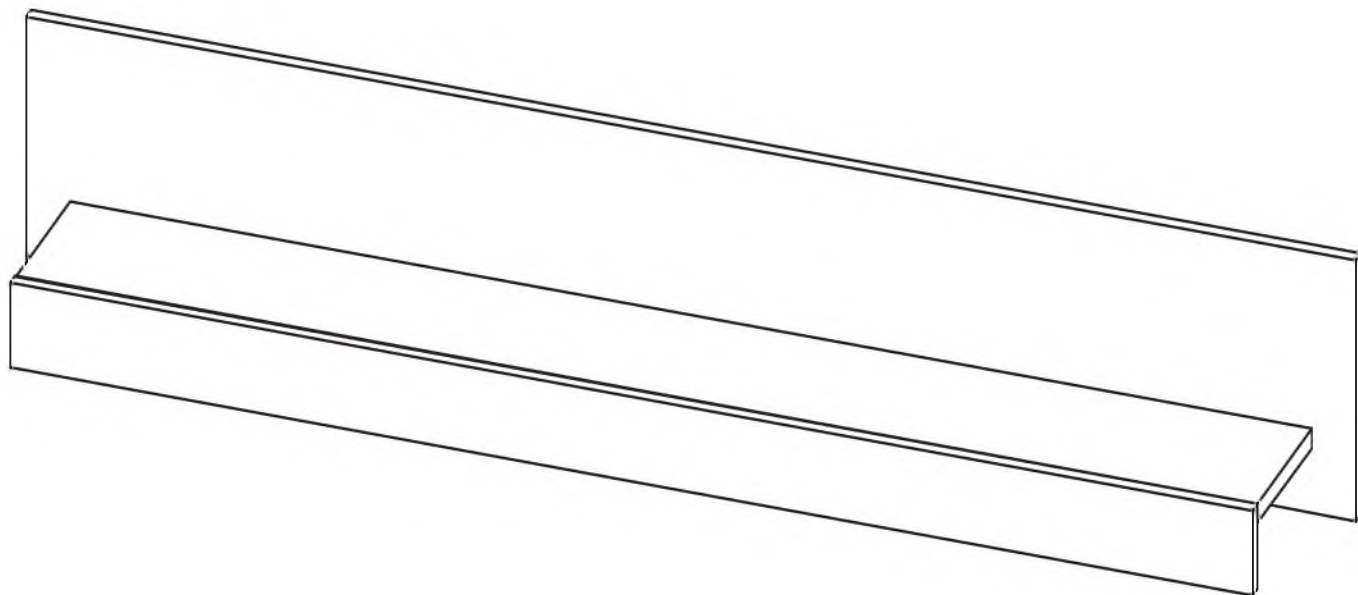
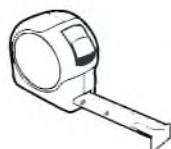

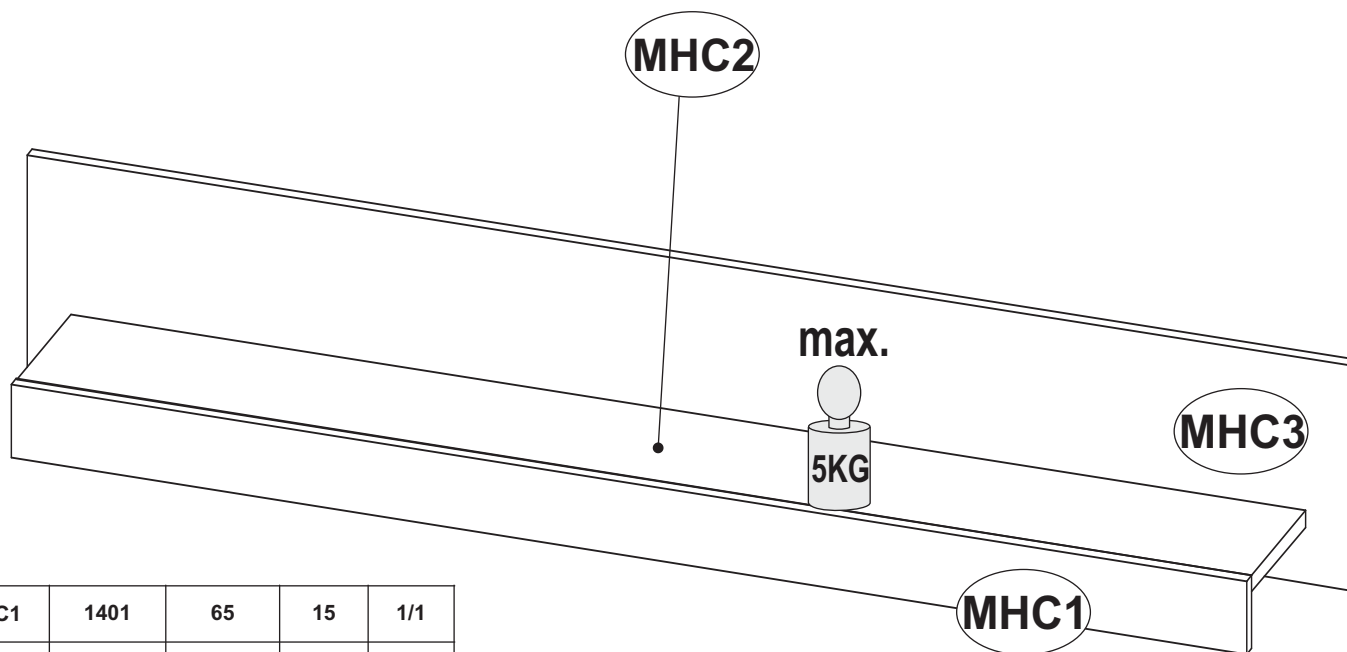

FLORENZ 71M

max.

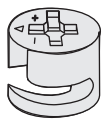

| | | | | |
|------|------|-----|----|-----|
| MHC1 | 1401 | 65 | 15 | 1/1 |
| MHC2 | 1400 | 169 | 15 | 1/1 |
| MHC3 | 1500 | 200 | 15 | 1/1 |

HCM1  123894
x5

HCK2  1311
7x70 x6

HCL15  6463
x2

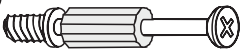
HCT1  11809
x5

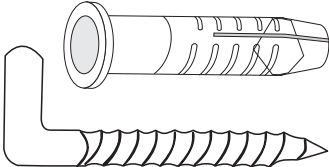
HCT10  1274
8281
x2

HCC6  00000
φ20 x5

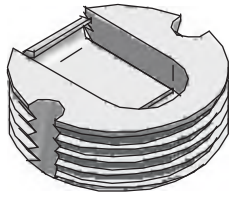
HCZ10  8704
x2

HCE6  1007
ES 6x9,5 x4

1

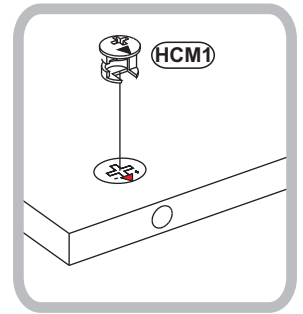
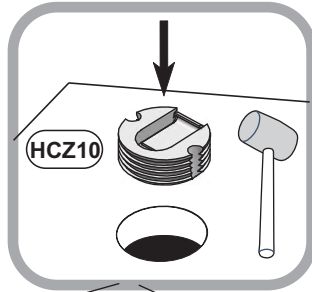
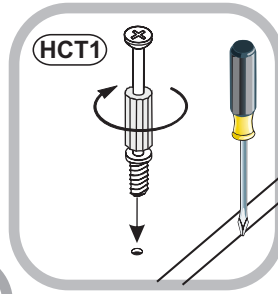
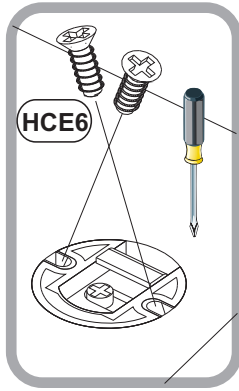

- HCZ10 8704 x2
- HCE6 1007 ES 6x9,5 x4
- HCM1 123894 x5
- HCT1 11809 x5

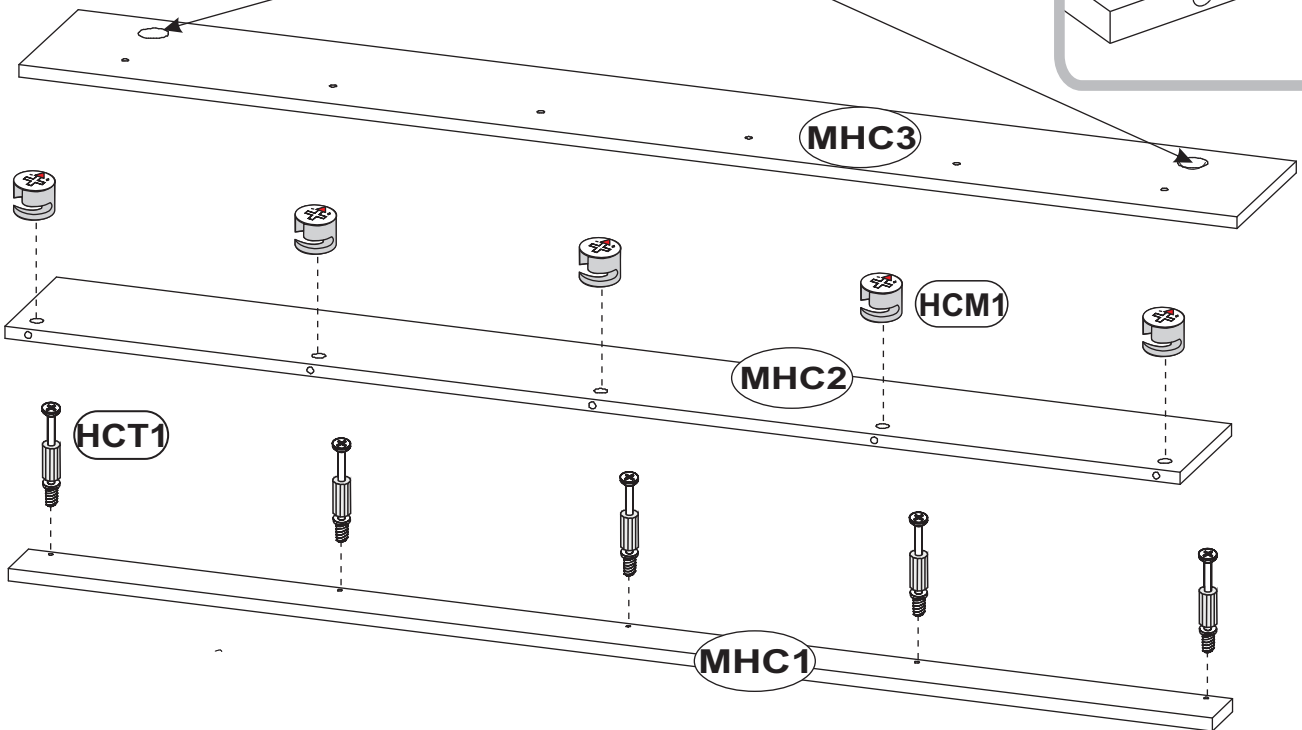

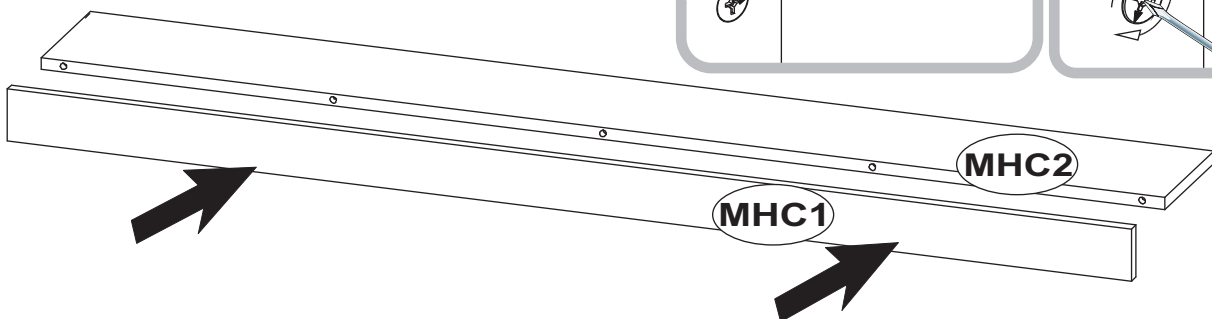
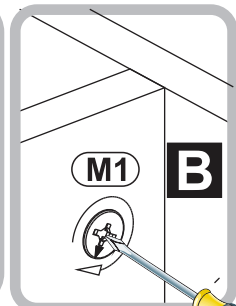
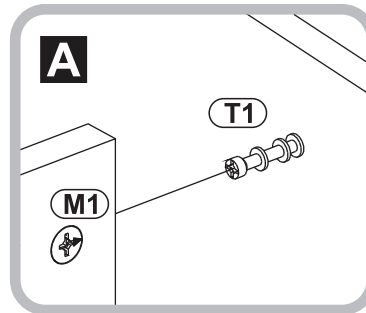

2

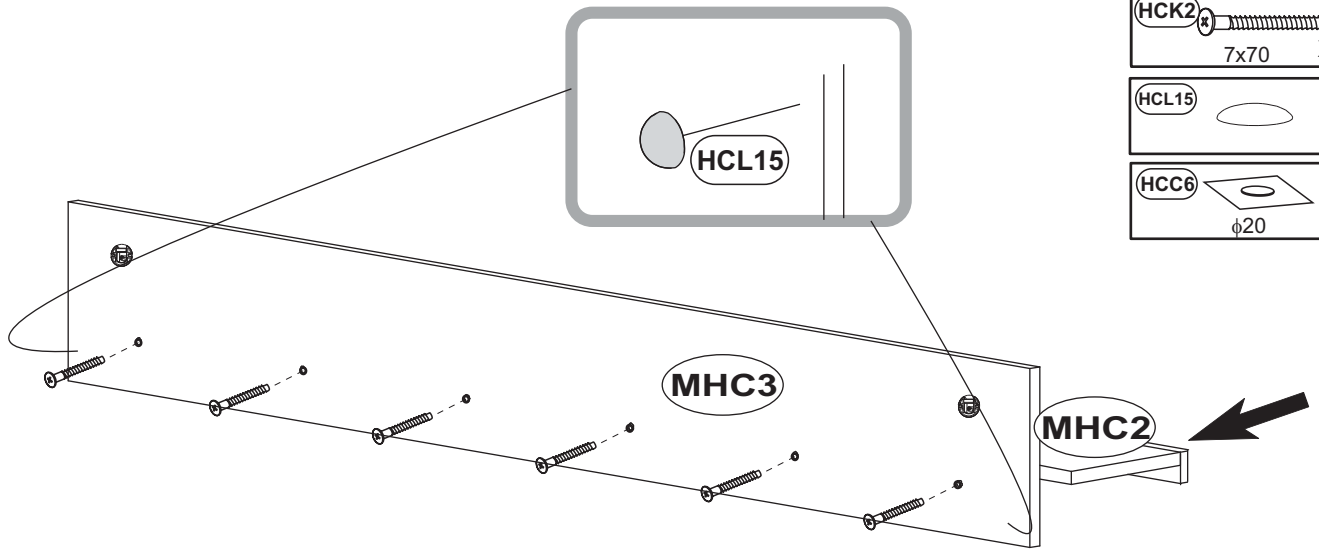

3

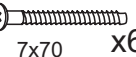

- HCK2**  7x70 x6
- HCL15**  6463 x2
- HCC6**  00000 φ20 x5

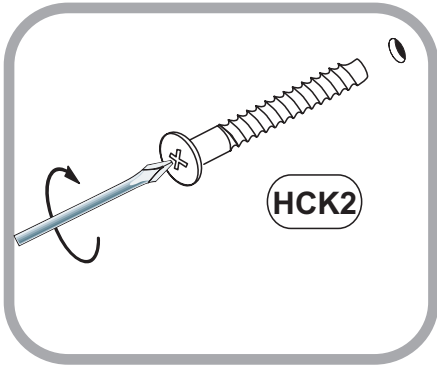

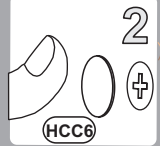
- 1  **HCC6**
- 2  **HCC6**

4

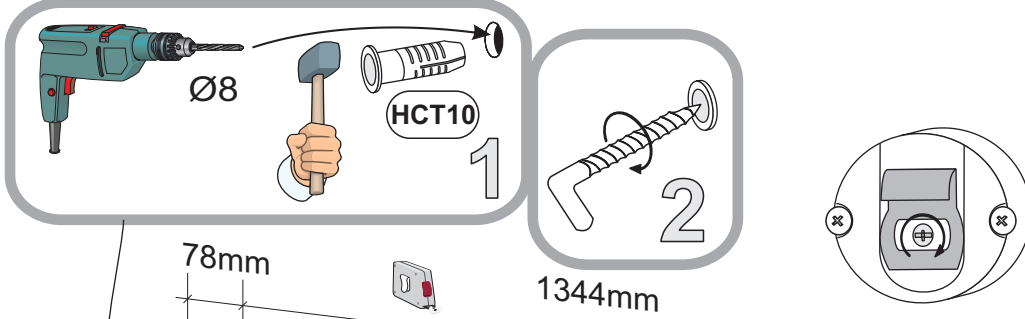

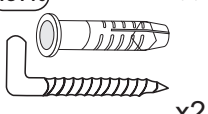
- HCT10**  1274 8281 x2

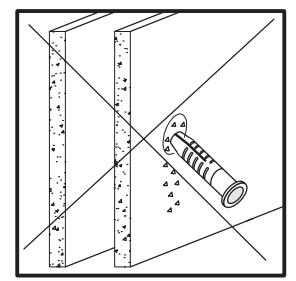
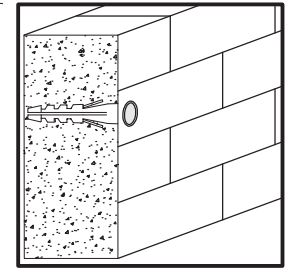
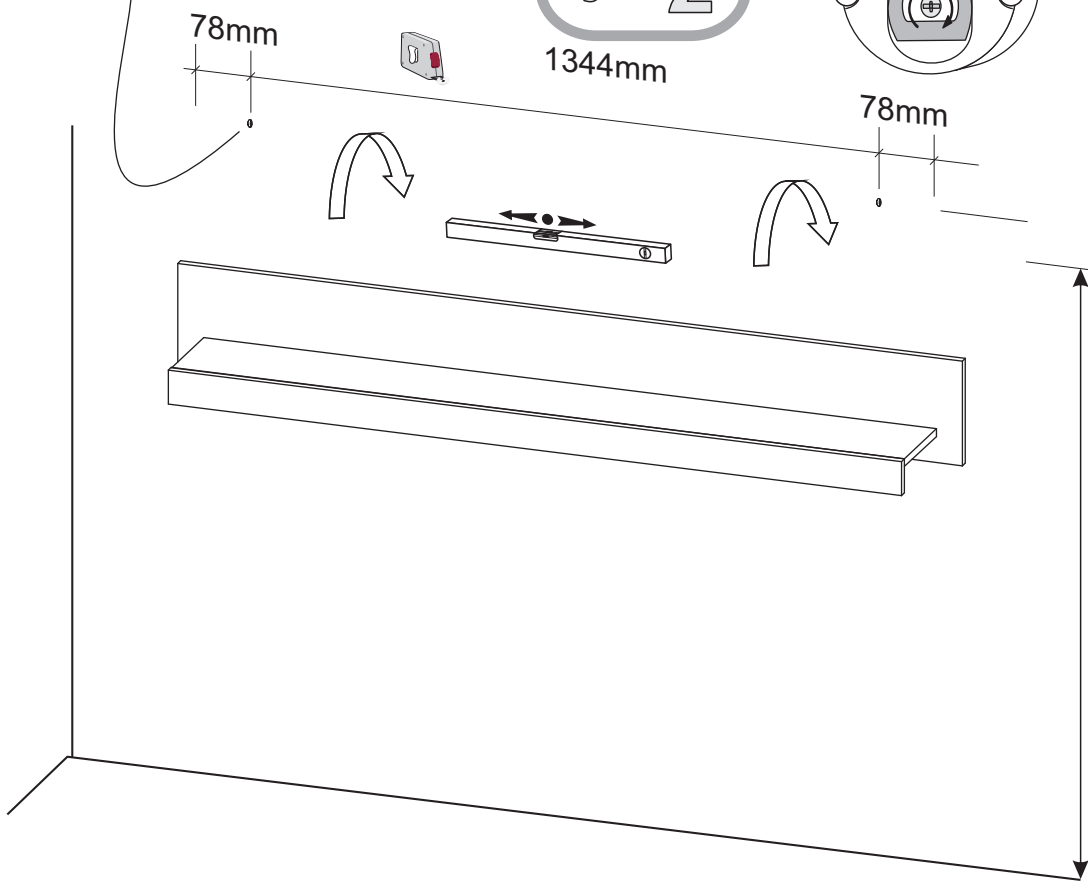

FLORENZ 71M

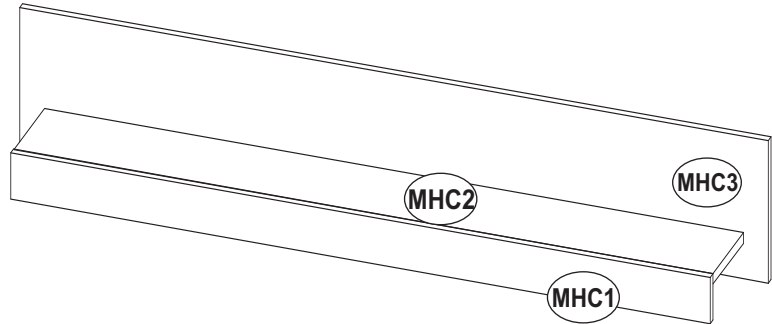

Unser Direktservice für Beschlagteile

D Sollte Ihnen ein Beschlagteil fehlen, können Sie diese Servicekarte direkt an die untenstehende Adresse mailen. Wir können allerdings nur Beschlagteile auf diesem Wege verschicken. Sollten Sie eine andere Beanstandung an Ihrem Möbelstück haben, so wenden Sie sich bitte direkt an Ihr Möbelhaus.

Our direct order service for fitting

GB If a fitting part is missing, you can e-mail this service card directly to the address below. However, we can only send fitting parts in this way. If you have any other cause for complaint concerning your item of furniture, please contact your furniture store directly.

Naše přímé služby pro kování

CZ Chybí-li vám nějaký díl z kování, můžete tuto servisní kartu odeslat e-mailem přímo na níže uvedenou adresu. Touto cestou však můžeme zoslat jen díly kování. Pokud byste reklamovali jiný díl nábytku, obraťte se přímo na svého prodejce nábytku.

Bien étudier la notice de montage

F S'il vous manque une ferrure, veuillez envoyer directement la présente carte service à l'adresse e-mail indiquée ci-dessous. Cependant, ceci nous permet uniquement d'envoyer des ferrures. Pour tout autre type de réclamation concernant votre meuble, veuillez contacter directement votre magasin d'ameublement.

Il nostro servizio diretto per l'ordine della ferramenta

I Qualora Vi dovesse mancare un pezzo di fissaggio, allora Vi preghiamo di inviare questa carta di servizio immediatamente all'indirizzo sottostante. Possiamo inviare i pezzi di fissaggio solamente per mezzo di questo procedimento. Qualora dovesse avere qualche altra reclamazione in merito al mobile, allora Vi preghiamo di rivolgerVi direttamente al Vostro Negozio di mobili.

Нашата директна услуга за обков

BG Ако липсват части от комплекта, попълнете настоящата сервисна карта и ни я изпратете на e-mail адреса, посочен по-долу. По този начин можем да доставяме само липсващи елементи от обкова. Ако установите други дефекти по мебелите, Ви съветваме да се обръщате към мебелната къща/магазин, от който сте закупили стоката.

Onze directservice voor losse onderdelen

NL Wanneer er een onderdeel ontbreekt, kunt u deze servicekaart direct aan onderstaand e-mailadres sturen. Wij kunnen langs deze weg echter alleen beslagdelen versturen. Mocht u een ander probleem aan uw meubel hebben, verzoeken wij u contact op te nemen met uw meubeldealer.

Nasz bezpośredni serwis części montazowych

PL Jeżeli brakuje części koniecznych do montażu, prosimy o przesłanie nam niniejszej karty serwisowej na niżej podany adres e-mailowy. W ten sposób możemy przelać Państwu tylko brakujące części. W przypadku innych reklamacji dotyczących mebla, prosimy zgłosić się do salonu meblowego, w którym został dokonany zakup.

Servis za okove

HR U slučaju da nedostaje neki od dijelova molimo vas da na dolje navedenu mail adresu pošaljete ovaj servisni obrazac. Na ovaj način mogu se dostaviti samo okovi. U slučaju da imate dodatne prigovore vezane uz komad namještaja molimo vas da se obratite izravno trgovini namještaja gdje je isti kupljen.

Direktszolpálatunk vasalatok esetén

HU Ha hiányzik egy vasalat, ezt a kártyát közvetlenül elküldheti az alább található címre. Azonban csakis vasalatoskat tudunk így küldeni. Amennyiben másfajta reklamációt áll fenn bútoráratját illetően, forduljon közvetlenül a bútorházhoz.

Náš priamy servis pre časti kovania

SK Ak by Vám chýbala nejaká časť kovania, môžete poslať túto servisnú kartu poslať e-mailom na nižšie uvedenú adresu. Diely kovania vieme poslať iba týmto spôsobom. Ak by ste mali inú reklamáciu ohľadom Vášho nábytku, obráťte sa priamo na Vašu predajňu nábytku.

Naše direktne uslužne storitve za okovje

SLO Če vam manjka kakšno okovje, lahko to servisno kartico pošljete po e-pošti direktno na spodnji naslov. Po tej poti vam lahko pošljemo samo okovje. Če želite reklamirati kakšen drug del pohištva, se obrnite neposredno na vašo trgovino pohištva.

Servicio-ul nostru direct pentru feronerie

RO In cazul in care va lipsesc o piesa de feronerie puteti sa trimiteți direct acest card de service prin e-mail la adresa de mai jos. Noi nu putem expedia piese de feronerie decât pe această cale. Dacă aveți o altă reclamație referitoare la piesa de mobilier, atunci vă rugăm să vă adresați direct la magazinul dvs. de mobilă.

Наш прямой сервис для поставок фурнитуры

RUS Если окажется, что Вам не хватает того или иного элемента фурнитуры, Вы можете отправить сервисную карту по факсу непосредственно на нижеприведенный адрес электронной почты. Однако, таким образом мы можем переслать лишь фурнитуру. Если же у Вас возникнут иные претензии относительно приобретенной мебели, пожалуйста, обращайтесь непосредственно в организацию, осуществившую продажу.

Vr direktservice för beslagsdelar

S Om du saknar en beslagsdel kan du skicka detta servicekort direkt till e-postadressen som anges nedan. Tank på att detta är den enda möjligheten att skicka beslagsdelar till dig. Om du vill reklamera din möbel av en annan anledning mlste du kontakta ditt möbelhus direkt.

Nuestro servicio directo para accesorios

ES Si le falta algún accesorio, puede enviar esta tarjeta de servicio directamente a la siguiente dirección. No obstante, por este método solo podemos enviar accesorios. Si tiene alguna otra objeción sobre su mueble, consulte directamente con su mueblería.

Donatilar için doğrudan servisimiz

TR Bir donatınız eksikse bu servis kartını doğrudan aşağıda bulunan adrese doğrudan mail yazabilirsiniz. Sadece bu yolla donatılar gönderiliriz. Mobilyanızda başka şikayetleriniz varsa lütfen doğrudan mobilya satıcınıza danışın.

| | | | | |
|------|------|-----|----|-----|
| MHC1 | 1401 | 65 | 15 | 1/1 |
| MHC2 | 1400 | 169 | 15 | 1/1 |
| MHC3 | 1500 | 200 | 15 | 1/1 |

FLORENZ 71M

D

Unser Direktservice für Beschlagteile
Sollte Ihnen ein Beschlagteil fehlen, können Sie diese Servicekarte direkt an die untenstehende Adresse mailen. Wir können allerdings nur Beschlagteile auf diesem Wege verschicken. Sollten Sie eine andere Beanstandung an Ihrem Möbelstück haben, so wenden Sie sich bitte direkt an Ihr Möbelhaus.

Our direct order service for fitting
If a fitting part is missing, you can e-mail this service card directly to the address below. However, we can only send fitting parts in this way. If you have any other cause for complaint concerning your item of furniture, please contact your furniture store directly.

GB

CZ

Naše primé služby pro kování
Chybi-li vám nějaký díl z kování, můžete tuto servisní kartu odeslat e-mailem přímo na níže uvedenou adresu. Touto cestou však můžeme rozesílat jen díly kování. Pokud byste reklamovali jiný díl nábytku, obraťte se přímo na svého prodejce nábytku.

Bien étudier la notice de montage

F

S'il vous manque une ferrure, veuillez envoyer directement la présente carte service à l'adresse e-mail indiquée ci-dessous. Cependant, ceci nous permet uniquement d'envoyer des ferrures. Pour tout autre type de réclamation concernant votre meuble, veuillez contacter directement votre magasin d'ameublement.

Il nostro servizio diretto per l'ordine della ferramenta

I

Qualora Vi dovesse mancare un pezzo di fissaggio, allora Vi preghiamo di inviare questa carta di servizio immediatamente all'indirizzo sottostante. Possiamo inviare i pezzi di fissaggio solamente per mezzo di questo procedimento. Qualora dovete avere qualche altra reclamazione in merito al mobile, allora Vi preghiamo di rivolgerVi direttamente al Vostro Negozio di mobili.

Нашата директна услуга за обкова

BG

Ако липсват части от комплекта, попълнете настоящата сервисна карта и ни я изпратете на e-mail адреса, посочен по-долу. По този начин можем да доставяме само липсващи елементи от обкова. Ако установите други дефекти по мебелите, Ви съветваме да се обърнете към мебелната къща/магазин, от който сте закупили стоката.

Onze directservice voor losse onderdelen

NL

Wanneer er een onderdeel ontbreekt, kunt u deze servicekaart direct aan onderstaand e-mailadres sturen. Wij kunnen lange deze weg echter alleen beslagdelen versturen. Mocht u een ander probleem aan uw meubel hebben, verzoeken wij u contact op te nemen met uw meubeldealer.

PL

Nasz bezpośredni serwis części montażowych
Jeżeli brakuje części koniecznych do montażu, prosimy o przesłanie nam niniejszej karty serwisowej na niżej podany adres e-mailowy. W ten sposób możemy przesłać Państwu tylko brakujące części. W przypadku innych reklamacji dotyczących mebla, prosimy zgłosić się do salonu meblowego, w którym został dokonany zakup.

Служба за обкова

HR

U slučaju da nedostaje neki od dijelova molimo vas da na dolje navedenu mail adresu pošaljete ovaj servisni obrazac. Na ovaj način mogu se dostaviti samo okovi. U slučaju da imate dodatne prigovore vezane uz komad namještaja molimo vas da se obratite izravno trgovini namještaja gdje je isti kupljen.

Direktszolgalatunk vasalatok esetén

HU

Ha hiányzik egy vasalat, ezt a kártyát közvetlenül elküldheti az alább található címre. Azonban csak vasalatoskat tudunk így küldeni. Amennyiben másfajta reklamáció áll fenn bütördarabját illetően, forduljon közvetlenül a bütörházhoz.

Naš priamy servis pre časti kovania

SK

Ak by Vám chýbala nejaká časť kovania, môžete poslať túto servisnú kartu pošlou e-mailom na nižšie uvedenú adresu. Diely kovania vieme poslať iba týmto spôsobom. Ak by ste mali inú reklamáciu ohľadom Vášho nábytku, obráťte sa priamo na Vašu predajňu nábytku.

Naše direktno uslužbne storitve za okovje

SLO

Ce vam manjka kakšno okovje, lahko to servisno kartico pošljete po e-pošti direktno na spodnji naslov. Po tej poti vam lahko pošljemo samo okovje. Če želite reklamirati kakšen drug del pohištva, se obrnite neposredno na vašo trgovino pohištva.

Service-ul nostru direct pentru feronerie

RO

În cazul în care vă lipsește o piesă de feronerie puteți să trimiteți direct acest card de service prin e-mail la adresa de mai jos. Noi nu putem expedia piese de feronerie decât pe această cale. Dacă aveți o altă reclamație referitoare la piesa de mobilier, atunci vă rugăm să vă adresați direct la magazinul dvs. de mobila.

Наш прямой сервис для поставок фурнитуры

RUS

Если окажется, что Вам не хватает того или иного элемента фурнитуры, Вы можете отправить сервисную карту по факсу непосредственно на нижеприведенный адрес электронной почты. Однако, таким образом мы можем пересылать лишь фурнитуру. Если же у Вас возникли иные претензии относительно приобретенной мебели, пожалуйста, обращайтесь непосредственно в организацию, осуществившую продажу.

Vr direktservice för beslagsdelar

S

Om du saknar en beslagsdel kan du skicka detta servicekort direkt till e-postadressen som anges nedan. Tank på att detta är den enda möjligheten att skicka beslagsdelar till dig. Om du vill reklamera din möbel av en annan anledning måste du kontakta ditt möbelfhus direkt.

Nuestro servicio directo para accesorios

ES

Si le falta algún accesorio, puede enviar esta tarjeta de servicio directamente a la siguiente dirección. No obstante, por este método solo podemos enviar accesorios. Si tiene alguna otra objeción sobre su mueble, consulte directamente con su mueblería.

Donatilar için doğrudan servisimiz

TR

Bir donatınız eksikse bu servis kartını doğrudan aşağıda bulunan adrese doğrudan mail yazabilirsiniz. Sadece bu yolla donatıları gönderebiliriz. Mobilyanızda başka şikayetleriniz varsa lütfen doğrudan mobilya satıcınıza danışın.

