

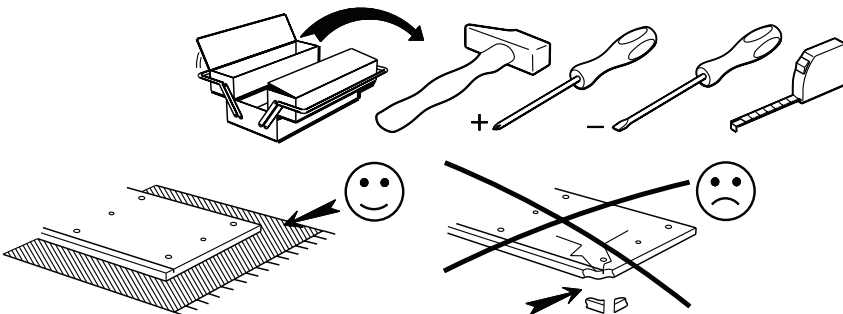

PARISOT INDUSTRIE

2273BURX

PARISOT INDUSTRIE 70800 SAINT LOUP SUR SEMOUSE -FRANCE-

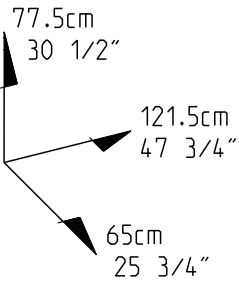
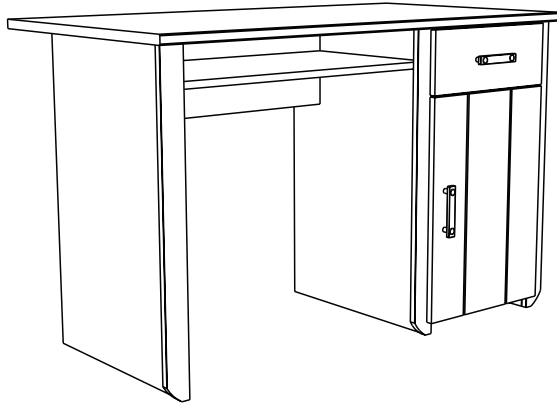
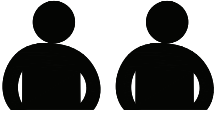
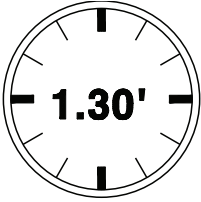

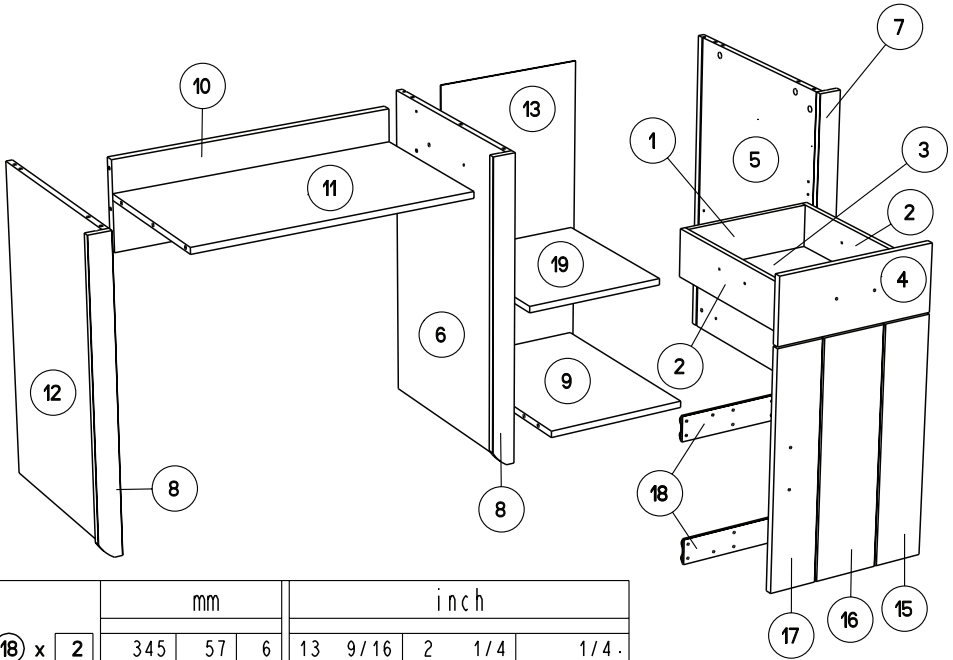
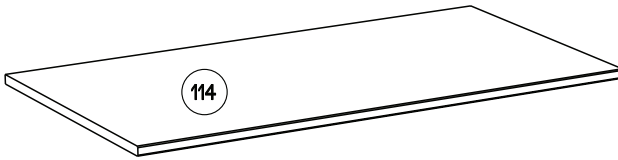

		mm			inch		
18	x 2	345	57	6	13 9/16	2 1/4	1/4
4	x 1	385	156	16	15 3/16	6 1/8	5/8
19	x 1	395	353	16	15 9/16	13 7/8	5/8
9	x 1	515	353	16	20 1/4	13 7/8	5/8
17	x 1	556	115	16	21 7/8	4 1/2	5/8
15	x 1	556	115	16	21 7/8	4 1/2	5/8
16	x 1	556	155	16	21 7/8	6 1/8	5/8
10	x 1	701	220	22	27 5/8	8 11/16	7/8
11	x 1	701	389	16	27 5/8	15 5/16	5/8
7	x 1	752	57	16	29 5/8	2 1/4	5/8
8	x 2	752	57	16	29 5/8	2 1/4	5/8
5	x 1	752	500	16	29 5/8	19 11/16	5/8
12	x 1	752	500	16	29 5/8	19 11/16	5/8
6	x 1	752	500	16	29 5/8	19 11/16	5/8
114	x 1	1212	650	22	47 11/16	25 9/16	7/8
2	x 2	400	110	13	15 3/4	4 5/16	1/2
1	x 1	302	110	13	11 7/8	4 5/16	1/2
3	x 1	399	313	3	15 11/16	12 5/16	1/8
13	x 1	703	369	3	27 11/16	14 1/2	1/8

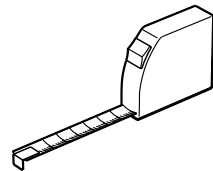

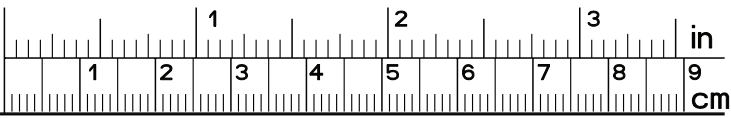

ADM x26



ADU x4

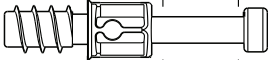

BSD x24



BWD x4



EP x2

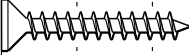

VJ x2

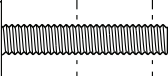

WZ x4



EO x1

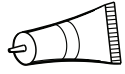

CF x1

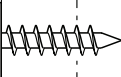

AMO x20



Ai x24



PU x3

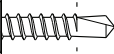

BRL x4

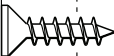

Vi x6



ANK x20

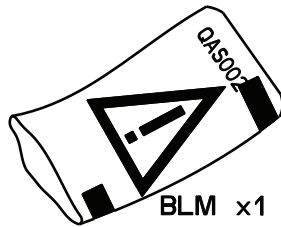

BLM x1

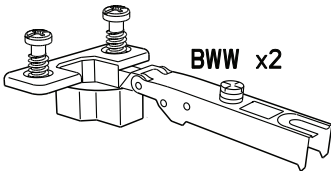

BWW x2

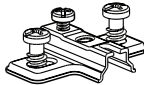

BWU x2

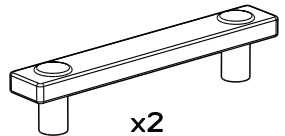

x2



AFM x1

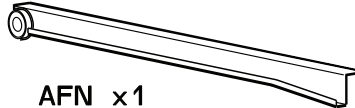

AFN x1



AFK x1

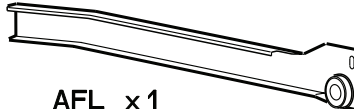

AFL x1

1

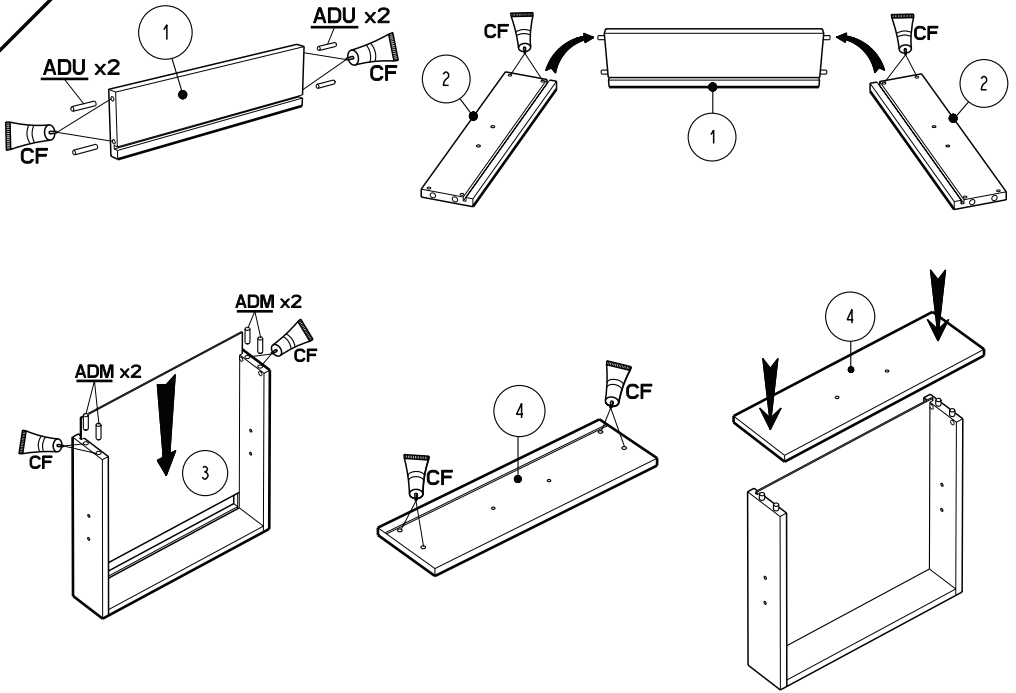

2

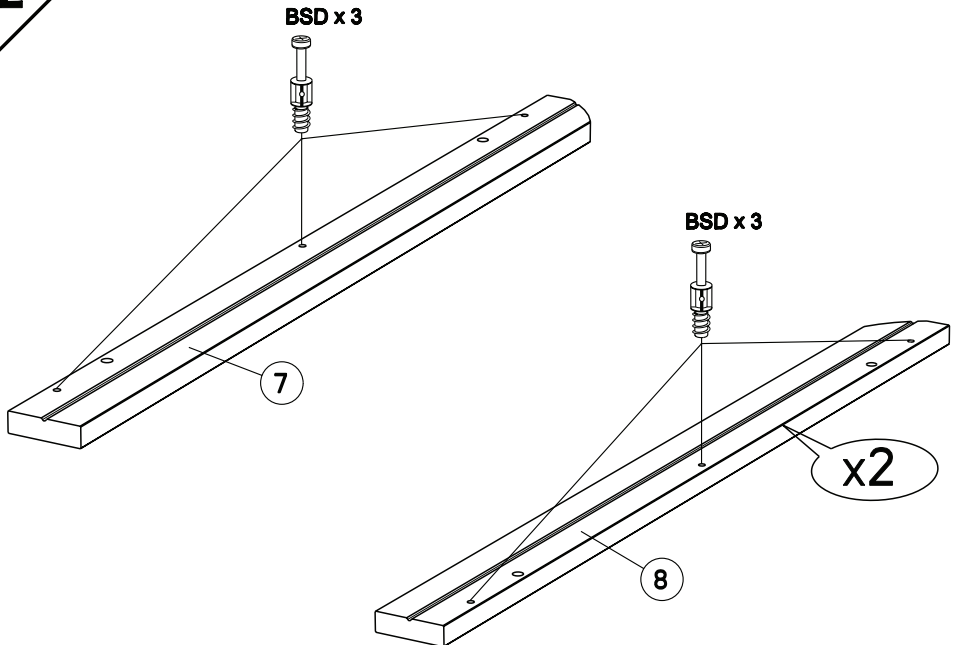

3

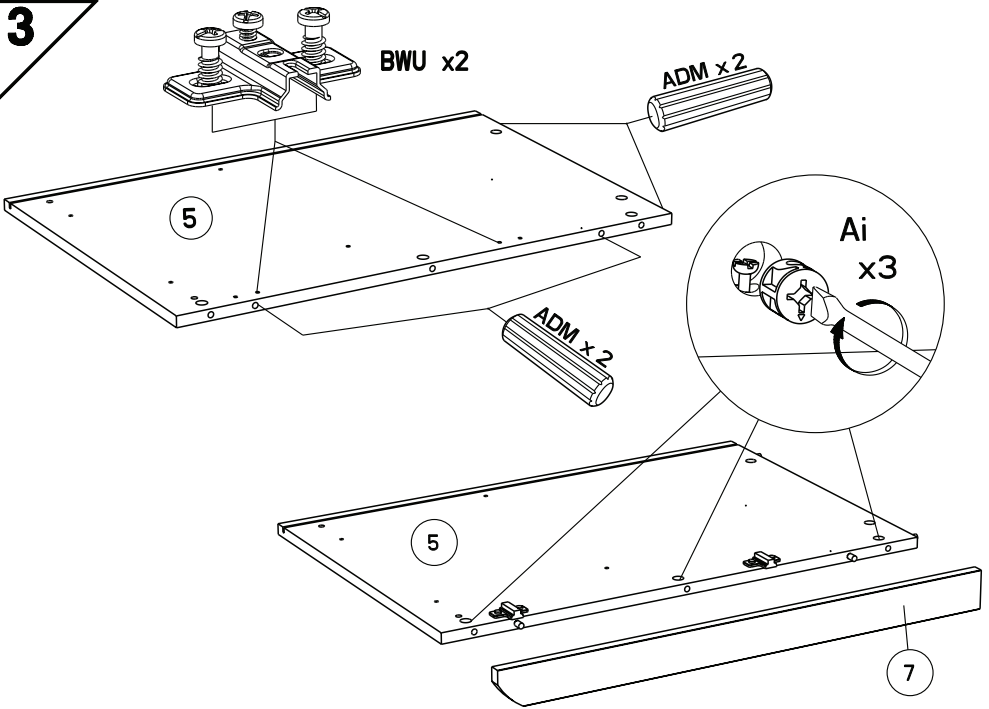

4

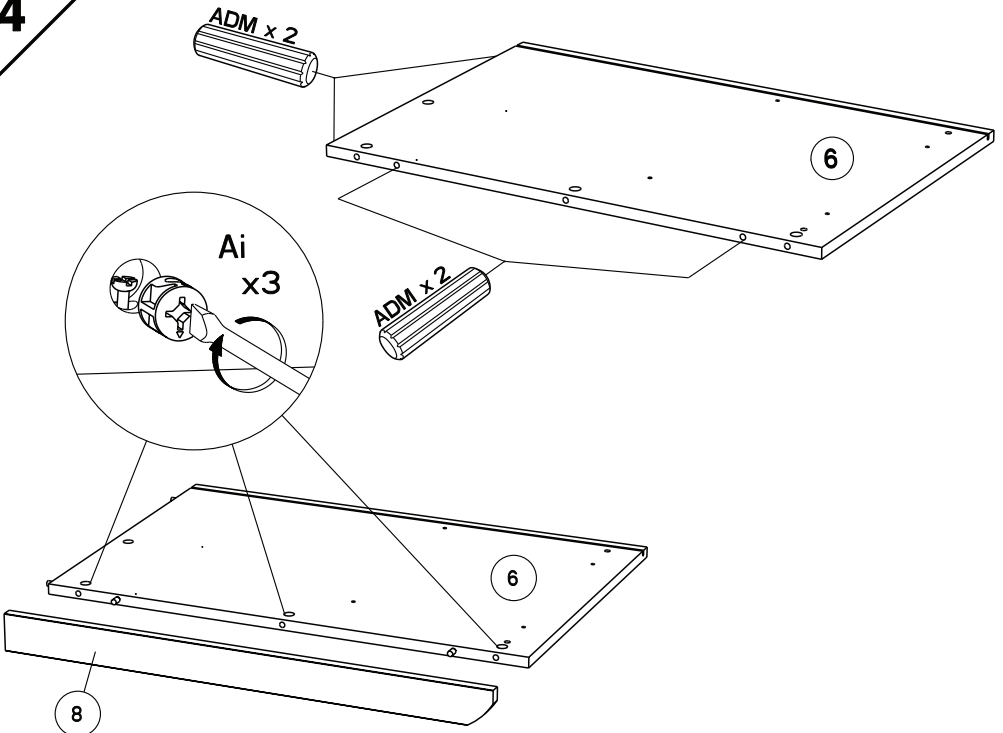

5

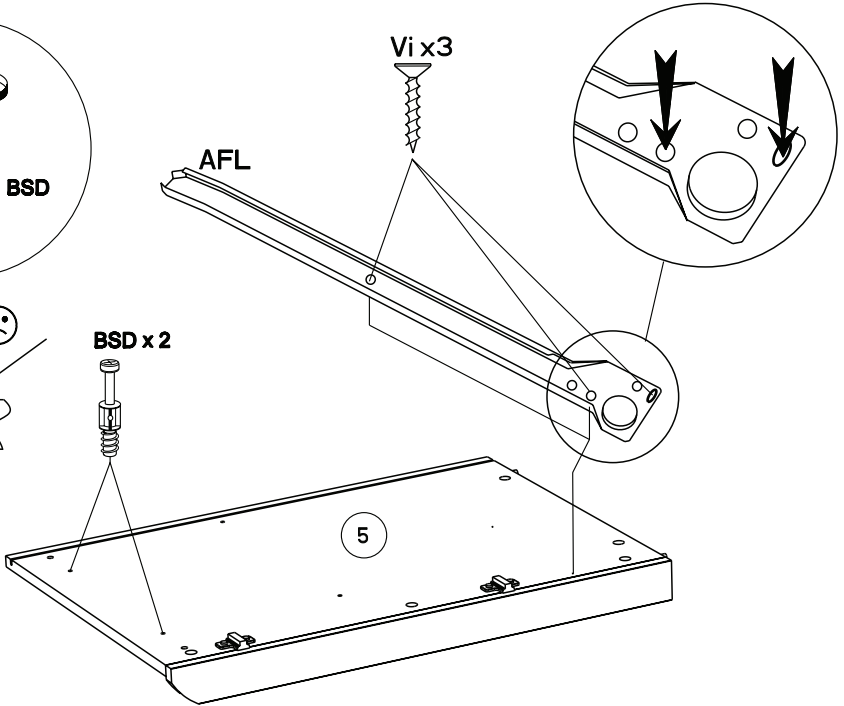
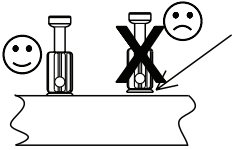
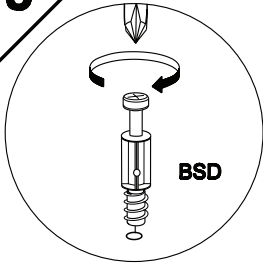

6

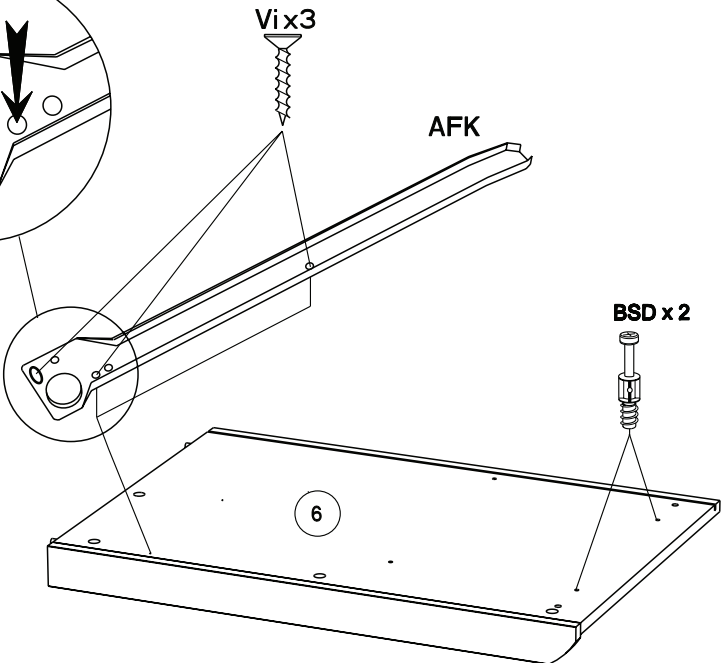
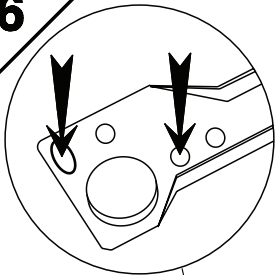

7

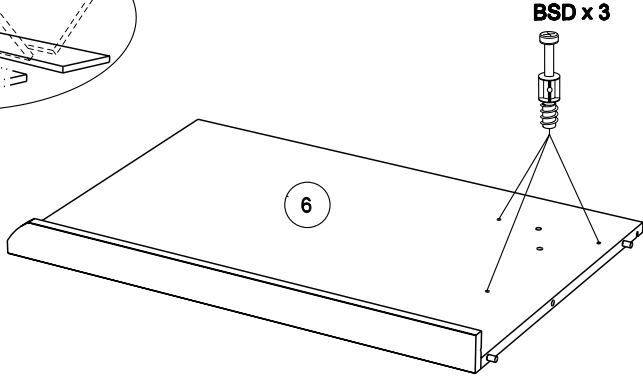
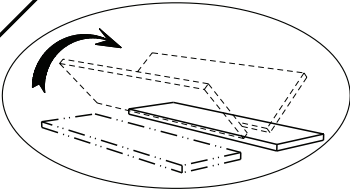

8

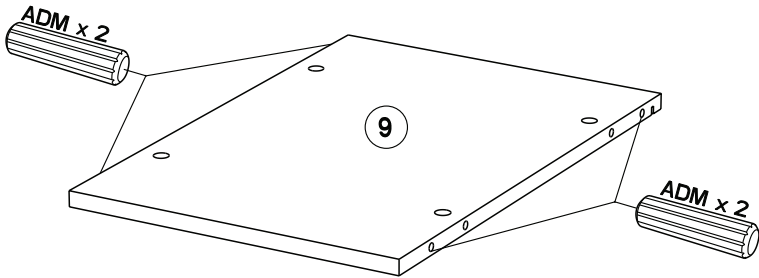

9

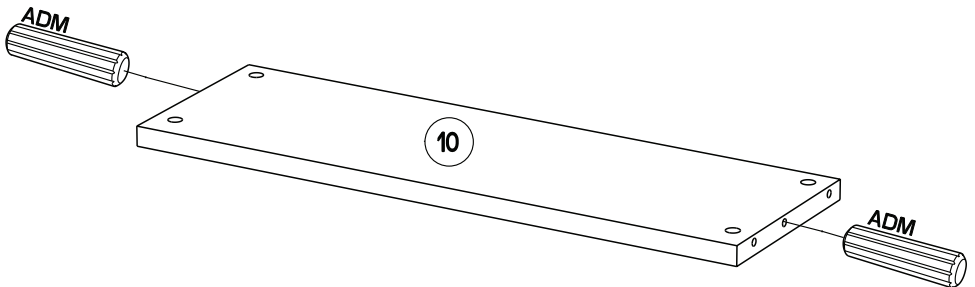

10

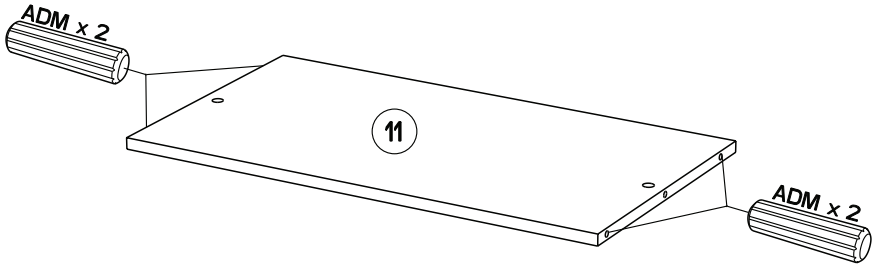

11

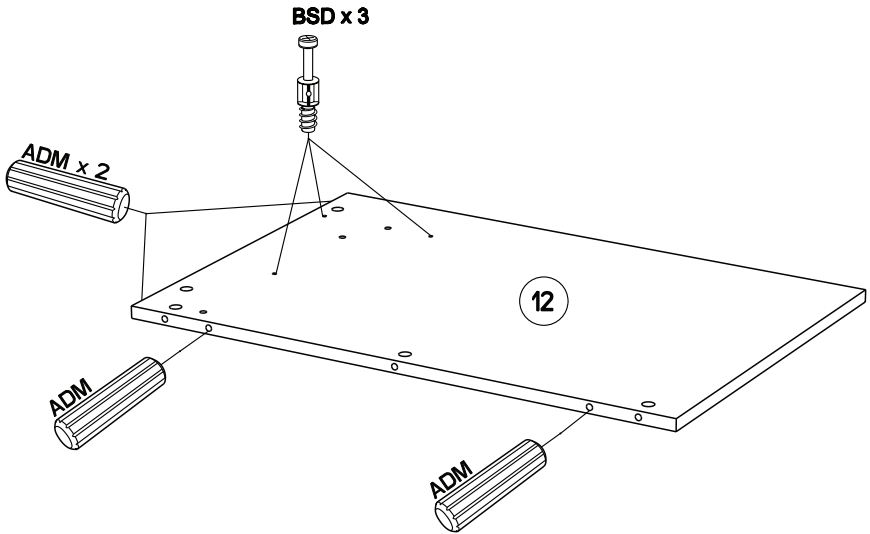

12

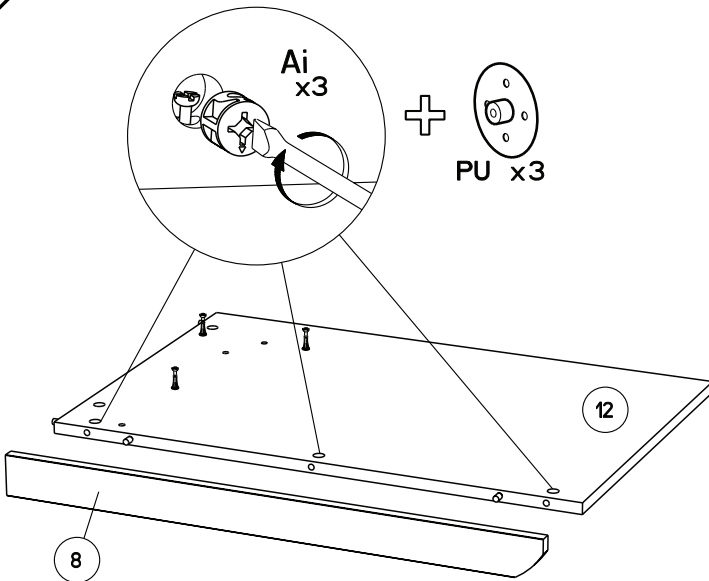

13

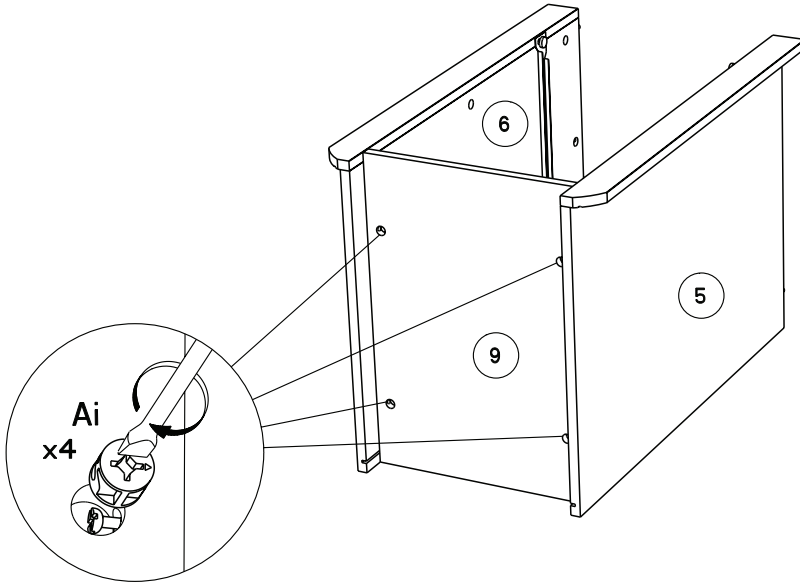

14

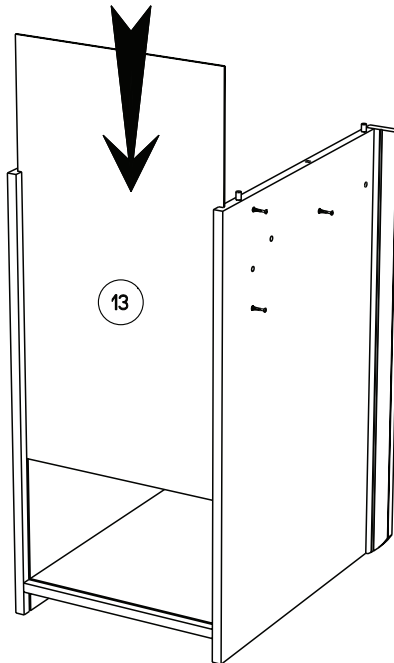

15

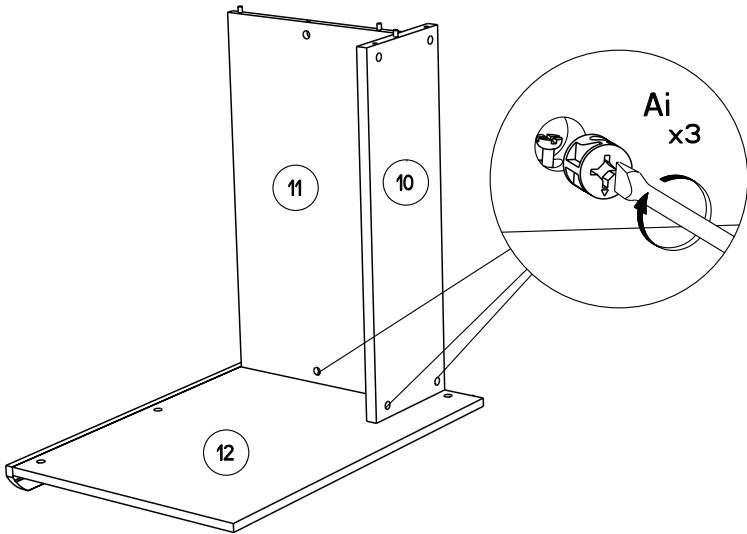

16

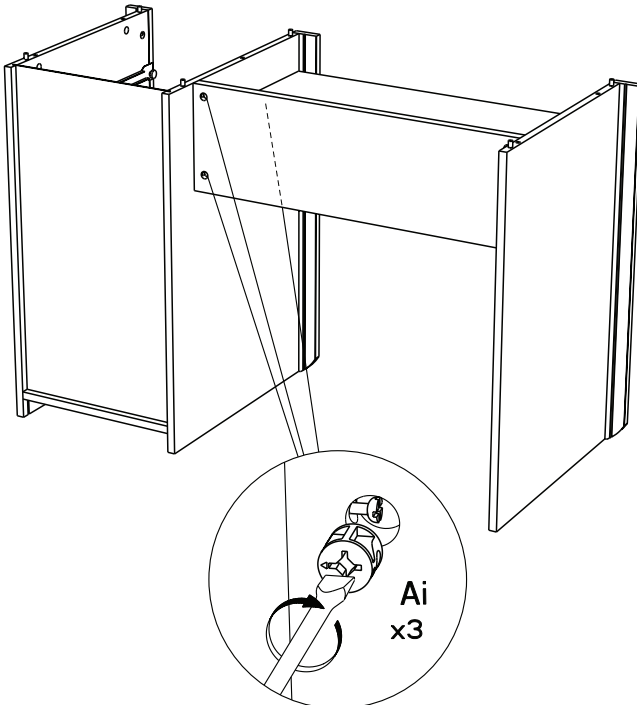

17

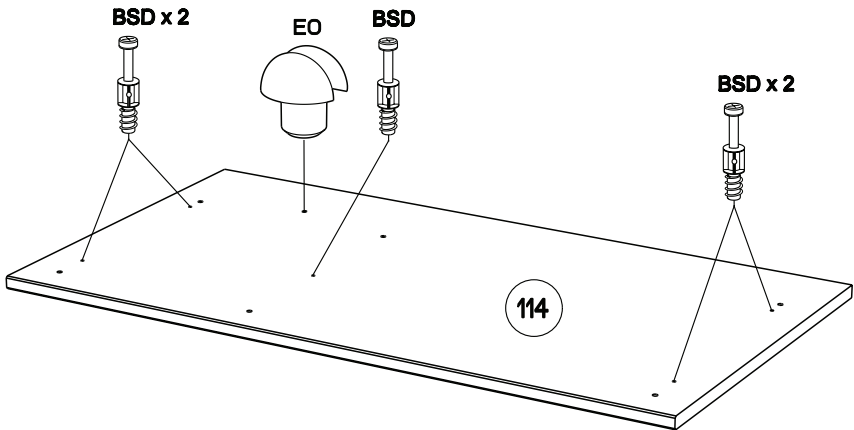

18

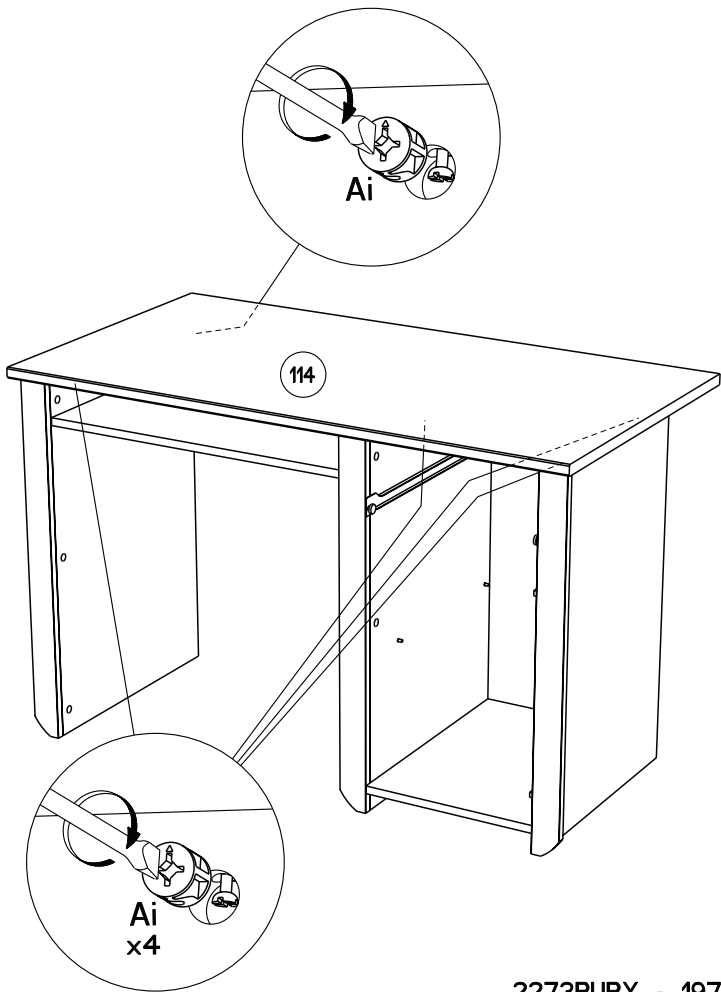

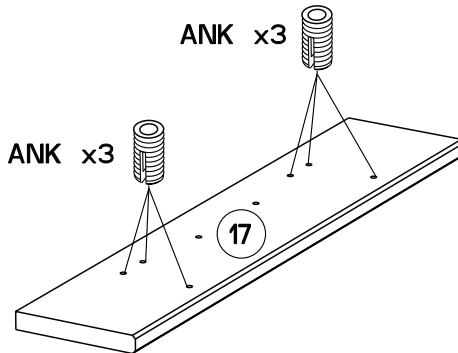
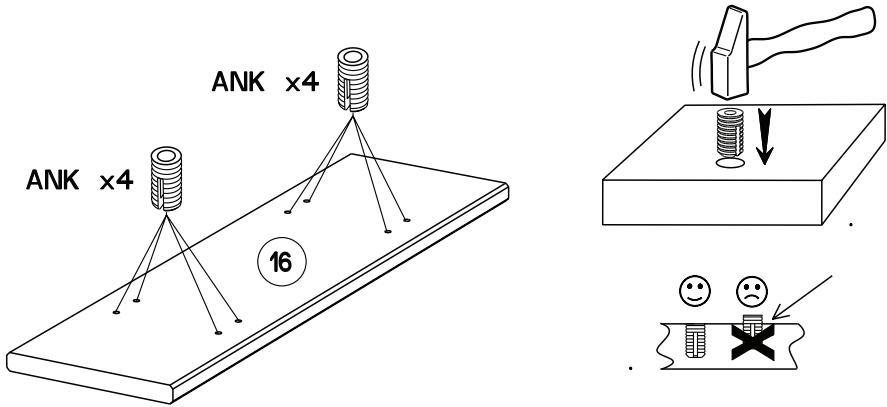
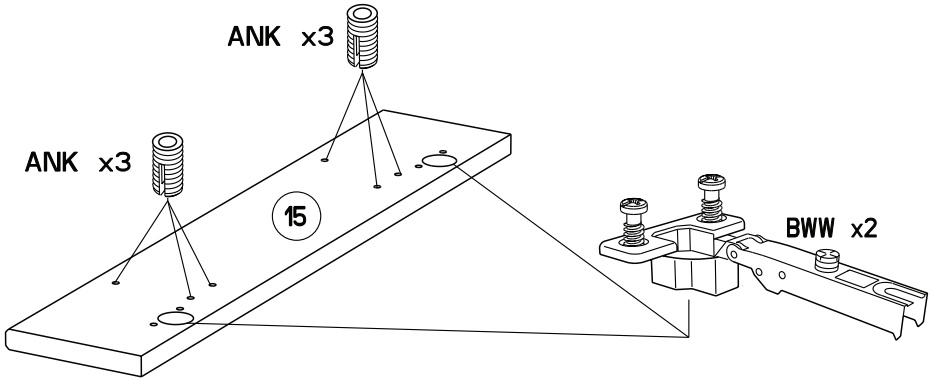

20

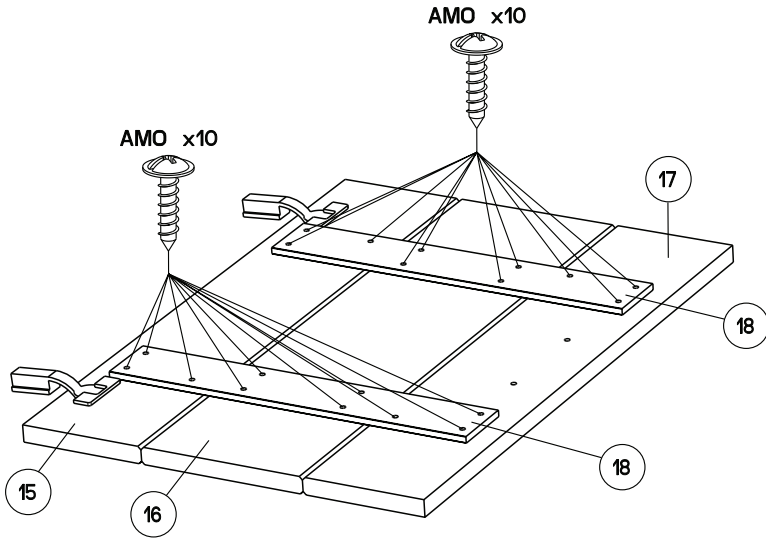

21

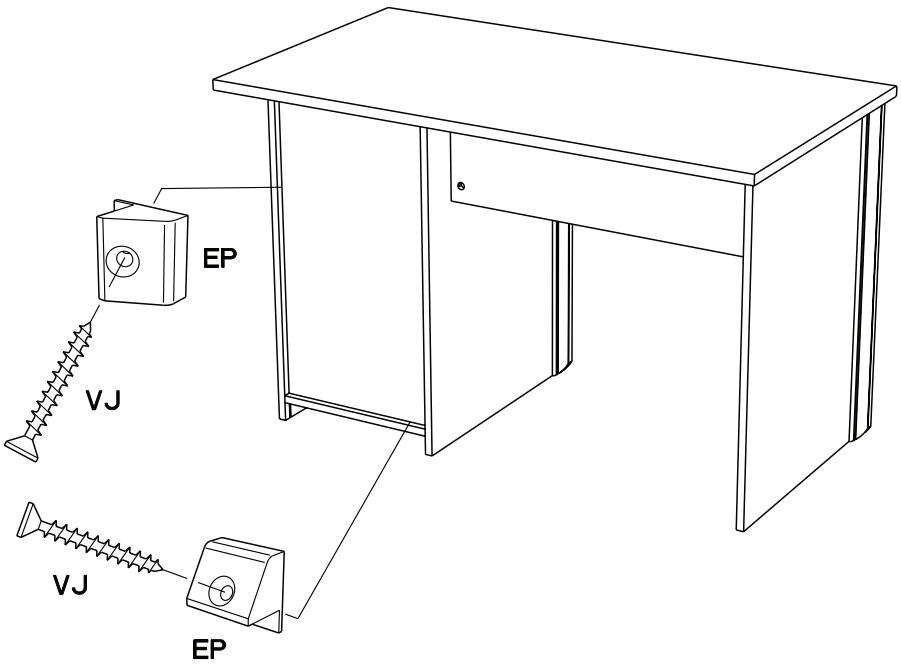

- FR** Pour votre sécurité : Fixation du meuble au mur.
Attention, la fixation doit être réalisée par une personne compétente car cela nécessite des chevilles adaptées à la nature de votre mur.
- EN** For your safety: the unit should be secured to the wall.
NB this should be carried out by a competent person as you must use the right rawlplug for your type of wall.
- DE** Zu Ihrer Sicherheit: Befestigen Sie das Möbel an der Wand.
Achtung: Diese Befestigung ist durch eine fachlich kompetente Person vorzunehmen.
Hierfür sind für die Bauweise Ihrer Wand geeignete Dübel einzusetzen.
- ES** Por su seguridad: Fijar el mueble a la pared.
Advertencia: la fijación la ha de llevar a cabo por personal adecuado, ya que requiere el uso de tacos que se adapten al tipo de pared.
- PT** Para sua segurança: fixação do móvel ao muro.
Atenção: a fixação deverá ser efetuada por pessoa habilitada, visto que são necessárias cavilhas adaptadas ao tipo de parede.
- IT** Avvertenza di sicurezza: il fissaggio del mobile a parete deve essere realizzato da una persona competente, in quanto l'operazione richiede l'impiego di tasselli adatti alla natura del muro.
- NL** Voor uw veiligheid: bevestiging van het meubel aan de muur.
Opgelet de bevestiging moet worden uitgevoerd door een bekwaam persoon daar dit voor uw type muur geschikte pluggen vereist.
- CZ** Z bezpečnostních důvodů: upevněte nábytek do zdi.
Pozor, upevnění je třeba svěřit kompetentní osobě, neboť vyžaduje hmoždinky vhodné pro vaši zeď.
- HU** Az Ön biztonsága érdekében : a bútor falra rögzítése.
Figyelmeztetés : a rögzítés csak megfelelő szakképesítéssel rendelkező személy által végezhető el, mert a rögzítéshez a falnak megfelelő csavarokra van szükség.
- PL** Dla bezpieczeństwa: mocowanie mebla do ściany.
Uwaga, mocowanie musi zostać wykonane przez osobę kompetentną, ponieważ wymaga to zastosowania kółków dostosowanych do rodzaju ściany.
- RO** Pentru securitatea dumneavoastră: fixarea mobilierului de perete.
Atenție, fixarea trebuie să fie realizată de o persoană calificată, deoarece sunt necesare dispozitive de fixare adaptate caracteristicilor peretelui dumneavoastră
- RU** Для вашей безопасности: Крепление мебели к стене
Внимание! Крепление должно производиться опытным специалистом, т.к. для такой установки потребуются штифты, соответствующие типу вашей стены.
- SK** Z bezpečnostných dôvodov. nábytok upevnite k stene.
Dbajte na to, aby upevnenie vykonala kompetentná osoba, pretože pri upevňovaní sa vyžadujú kolíky vhodné do materiálu, z ktorého je stena vyrobená.
- SL** Za vašo varnost: Enota naj bo pritrjena na steno. Pozor: To naj stori kompetentna oseba, ker je potrebno uporabiti pravilni nosilec glede na vrsto stene ki jo uporabljate.
- TR** Güvenliğiniz için: Mobilyanın duvara sabitlemesi
Dikkat, sabitleme işlemi uzman biri tarafından yapılmalıdır çünkü bu işlem için duvarınızın malzemesine uygun dübellerin kullanılması gerekmektedir
- EL** Για την ασφάλειά σας : στερέωση των επίπλων στον τοίχο.
Προσοχή, η στερέωση πρέπει να γίνεται από ικανό άτομο, καθώς απαιτούνται σφήνες προσαρμοσμένες στη φύση του τοίχου σας.

AR لسلامتك الشخصية: تثبيت قطعة الأثاث على الحائط

تحذير، يجب أن يقوم شخص متخصص بعملية التثبيت على الحائط إذ أنها تتطلب اسفينا معينا يتوافق مع طبيعة الحائط نفسه.

ZH 为了您的安全：本产品必须靠墙安装。

NB 本产品必须由专业人士安装，且您必须使用符合您的墙壁类型的罗威纤维管。

22

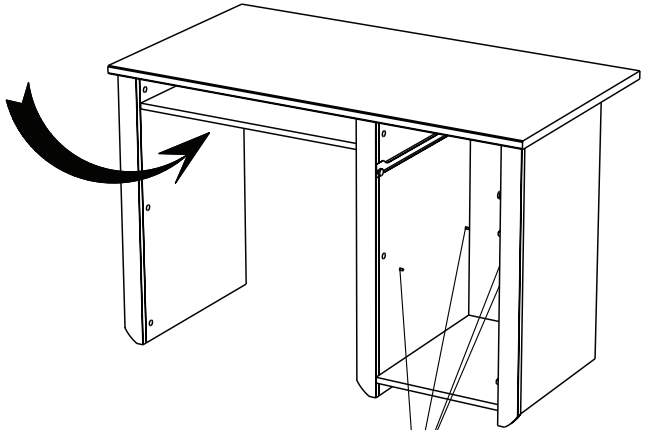
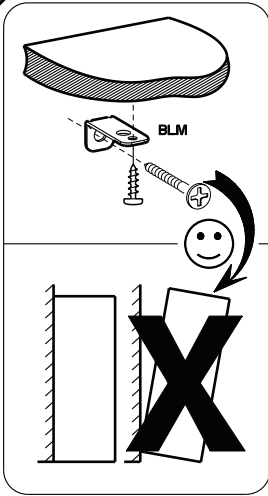

BWD x 4

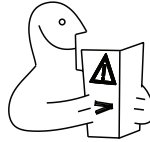
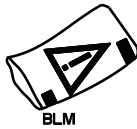
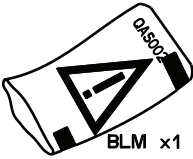

23

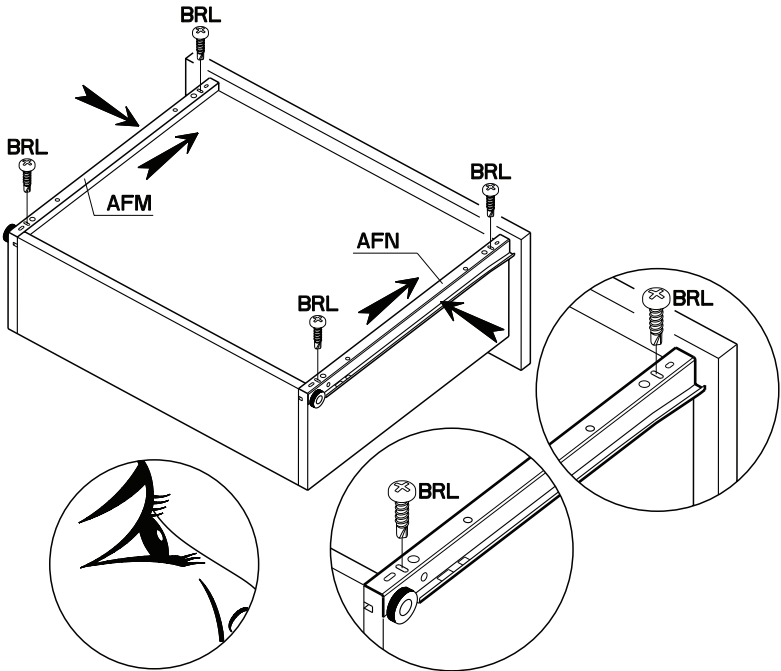

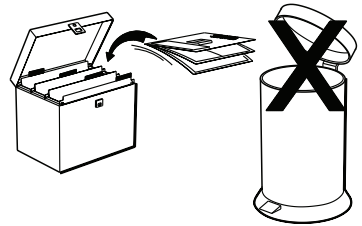
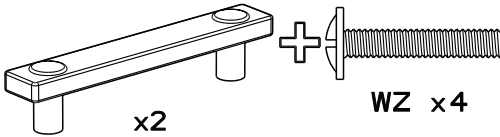
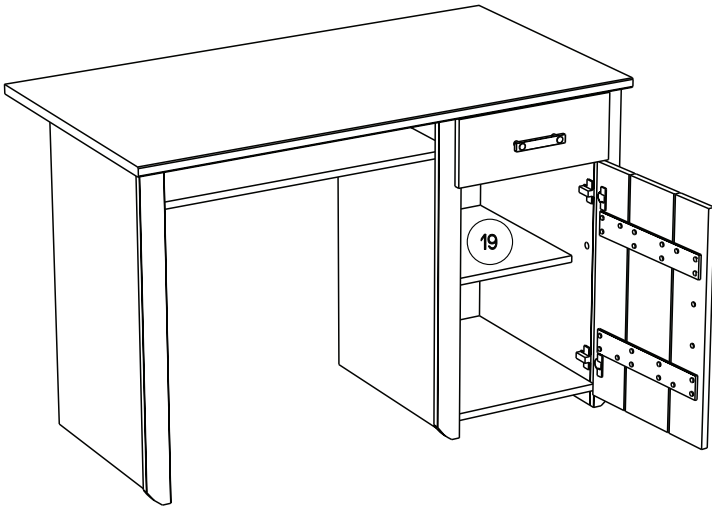

Faites un geste pour l'environnement en triant vos déchets d'emballage
 Make a gesture for the environment by sorting out your waste of packaging
 Machen Sie eine Bewegung für die Umwelt, ihre Verpackungsabfälle sortierend
 Haga un gesto para el medio ambiente escogiendo sus residuos de embalaje

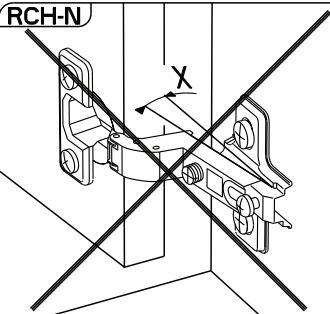

MONTAGE

- (GB) LEAFLET
- (D) AUFBAUANLEITUNG
- (E) MONTAJE
- (P) MONTAGEM
- (I) MONTAGGIO
- (NL) MONTAGE

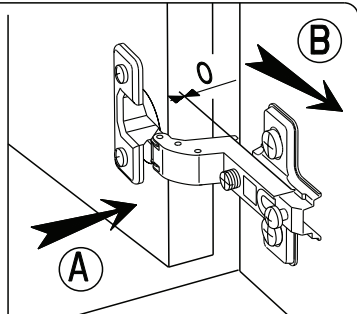

REGLAGE (GB) ADJUSTING (E) A.JUSTER (I) AGGIUSTAMENTO
 (D) ANPASSUNG (P) REGULACAO (NL) AFSTELLING

