

80-20101-40

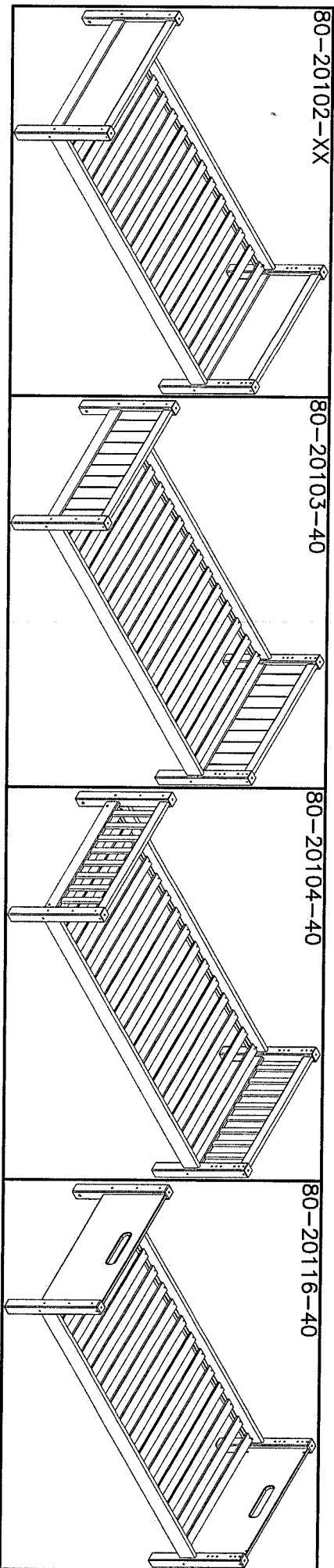

See assembly instruction in box no.
 Voir notice de montage dans la coisse no.
 Siehe Aufbauanleitung im Karton no.
 Zie voor de montage-instructie pakketnr.

Before assembling this product, please ensure that all the components supplied comply with the list on this page. All Screw-type fittings can be tightened with this tool.

Avant de commencer l'assemblage, veuillez contrôler si tous les objets indiqués sont présents. Tous les vis peuvent être serrés par cet outil.

Bevor Sie mit dem Aufbau beginnen, kontrollieren Sie ob alle auf der Zeichnung angegebenen Teile vorhanden sind. Bitte verwenden Sie zur Montage einen Kreuzschraub-zehler und den beiliegenden Inbenschlüssel.

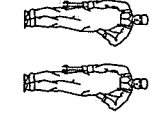

Ware-nr. Part no. Ref No	Stück- Qty. Qté.
Siehe Bild-nr. See picture no. Image no	Mess- Dim. Dim.

12-06306473-40

2 Stück/pcs.

12-06306474-40

2 Stück/pcs.

1305-19672-40

2 Stück/pcs.

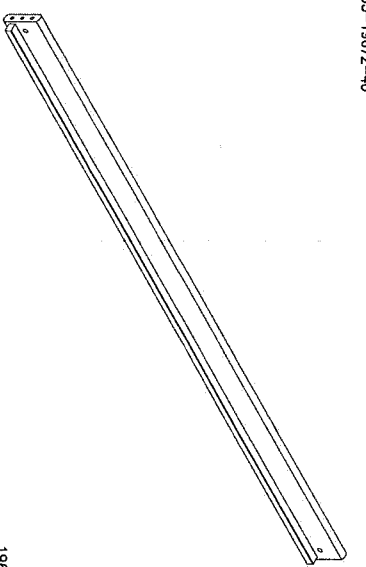
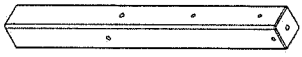
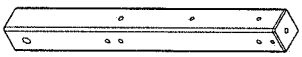

1967x115x26

A

B

C

3922-08018 8 Stück/pcs.

647x63x63

3930-10050 16 Stück/pcs.

3909-70100

647x63x63

4 Stück/pcs.

3901-40030

30 Stück/pcs.

1967x115x26



Z1 M6/ø12x18 mm.

Z2 ø10x50 mm.

Z3 16 Stück/pcs.

Z4 ø7x100 mm.

Z5 ø4x30 mm.

Z6 M6x110 mm.

Z7 ø8 mm.

Z8 ø10 mm.

Z9 4033-005

1 Stück/pcs.

5 mm.

3913-08110

8 Stück/pcs.

3938-000081-2

20 Stück/pcs.

3938-00010-2

4 Stück/pcs.

3938-00016-2

4 Stück/pcs.

4033-005

1 Stück/pcs.

5 mm.

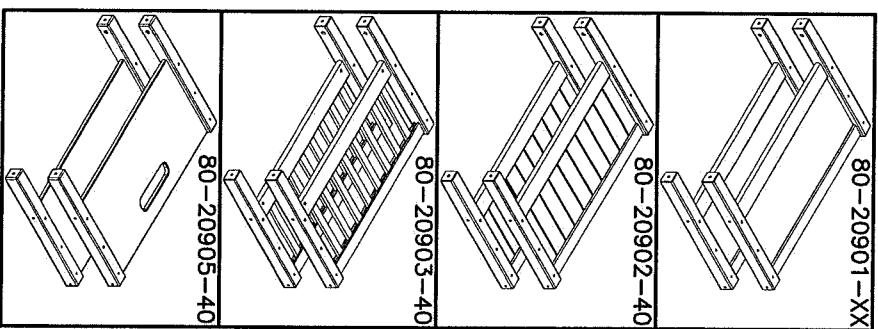

80-20905-40 White

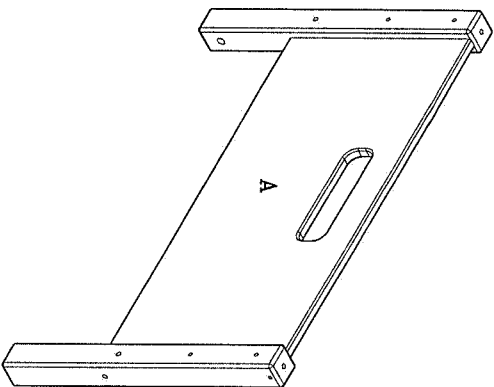

Before assembling this product, please ensure that all the components supplied comply with the list on this page. All Screw-Type fittings can be tightened with this tool.

Avant de commencer l'assemblage, veuillez contrôler si tous les objets indiqués sont présents. Tous les vis peuvent être serrés par cet outil.

Bevor Sie mit dem Aufbau beginnen, kontrollieren Sie ob alle auf der Zeichnung angegebenen Teile vorhanden sind. Bitte verwenden Sie zur Montage einen Kreuzschraub-zähler und den beiliegenden Innesschlüsselsatz!

Ware-nr. Part no. Ref No. Stück Qty. Dim. Mass

4301-2208631-40 2 stick/pcs.

<p>883x431x22 Z29</p>	<p>Z28 M6/Ø10x18mm 4 stick/pcs.</p>	<p>Z29 4 stick/pcs. 4035-004 1 stick/pcs. 4 mm.</p>
-----------------------	-------------------------------------	---

Z1, Z2, Z5 Fittings in single / bunk bed box.
 Z1, Z2, Z5 Beschläge im Einzel- / Etagenbett Karton.
 Z1, Z2, Z5 Raccords en lit simple / lit superposé.
 Z1, Z2, Z5 Fittings in het enkelspel / stapelbed boxen.

<p>1</p> <p>Z2 x8 pcs.</p> <p>x2</p>	<p>Bunk bed only. Nur Etagen Bett. Lits superposés seulement. Alleen stapelbed</p>	
<p>2a</p> <p>Z29 x2 pcs.</p> <p>Z1 x2 pcs.</p> <p>Z28 x2 pcs.</p> <p>x2</p>	<p>x2</p>	<p>2b</p> <p>Z29 x2 pcs.</p> <p>Z1 x2 pcs.</p> <p>Z28 x2 pcs.</p> <p>x2</p>
<p>3a</p> <p>Z29 x2 pcs.</p> <p>Z5 x2 pcs.</p> <p>Z1 x2 pcs.</p> <p>Z28 x2 pcs.</p> <p>x2</p>	<p>x2</p>	<p>3b</p> <p>Z29 x2 pcs.</p> <p>Z5 x2 pcs.</p> <p>Z1 x2 pcs.</p> <p>Z28 x2 pcs.</p> <p>x2</p>

80-20604-40

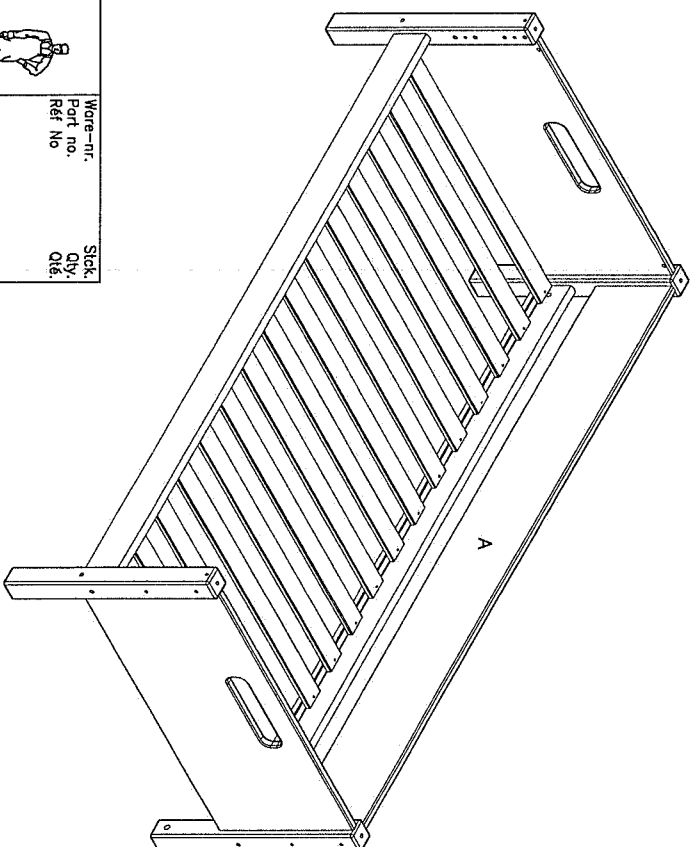

Before assembling this product, please ensure that all the components supplied in the package are present. At the last of this page, a list of the parts to be tightened with this tool.



Avant de commencer l'assemblage, veuillez contrôler si tous les objets indiqués sont présents, tous les vis peuvent être serrés par cet outil.

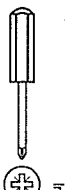

Bevor Sie mit dem Aufbau beginnen, kontrollieren Sie ob die auf der Zeichnung angegebenen Teile vorhanden sind. Bitte wenden Sie zur Montage einen Schraubenzieher und den benötigten Innensechskantschlüssel.



4301-2219675-40 1 stick/pcs.

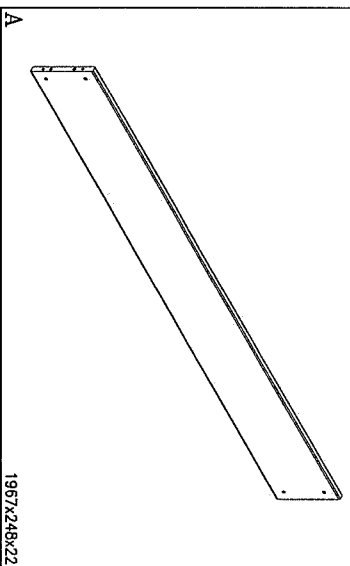

A 3930-10050 4 stick/pcs. 3922-060181 4 stick/pcs.



Z2 Ø10x50 mm. Z28 M6/Ø10x18mm 4 stick/pcs. 4033-004 1 stick/pcs.

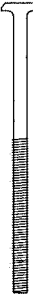

Z29 M6x110 mm. 4 mm.

Ware-nr. Part no.	Stück. Qty. Qté.
Stahle Bild-nr. See picture no.	Mass. Dim.
Intégre no	

See assembly instruction in box no. 80-20101-40

Voir notice de montage dans la caisse no. 80-20101-40

Siehe Aufbauanleitung im Karton no. 80-20101-40

Zie voor de montage-instructie pakketnr. 80-20101-40

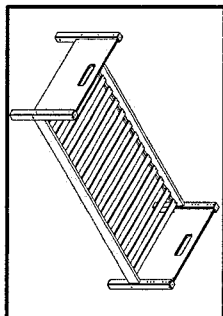

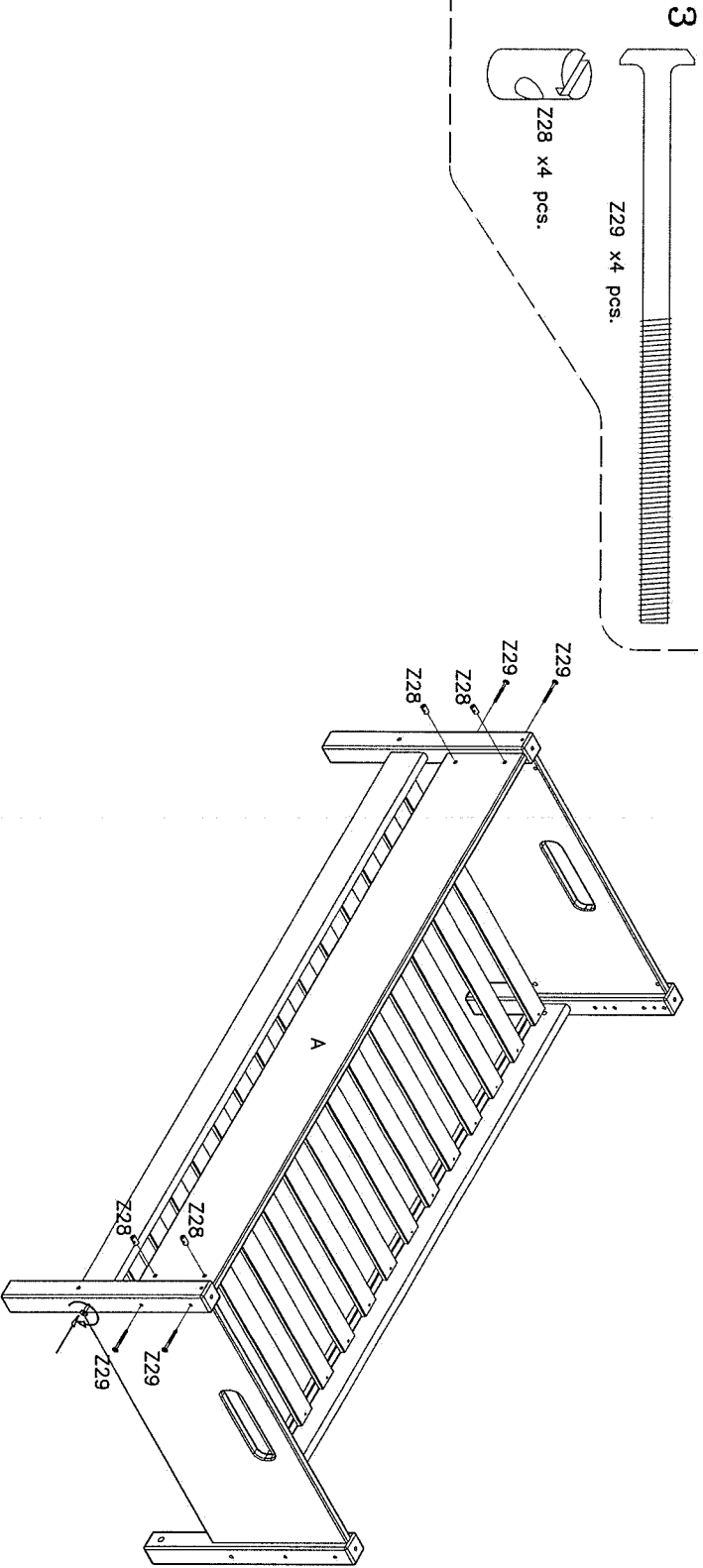
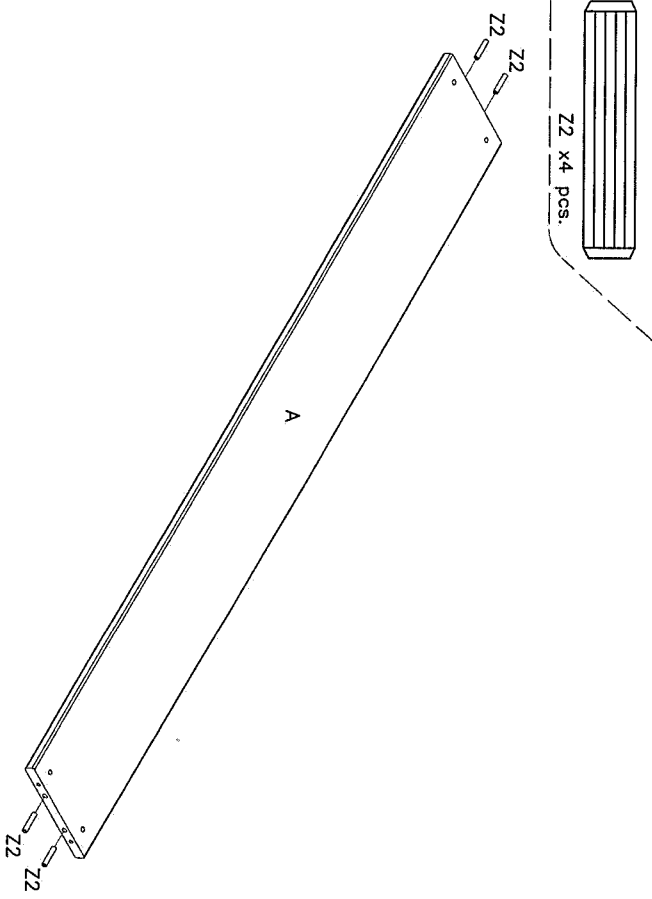
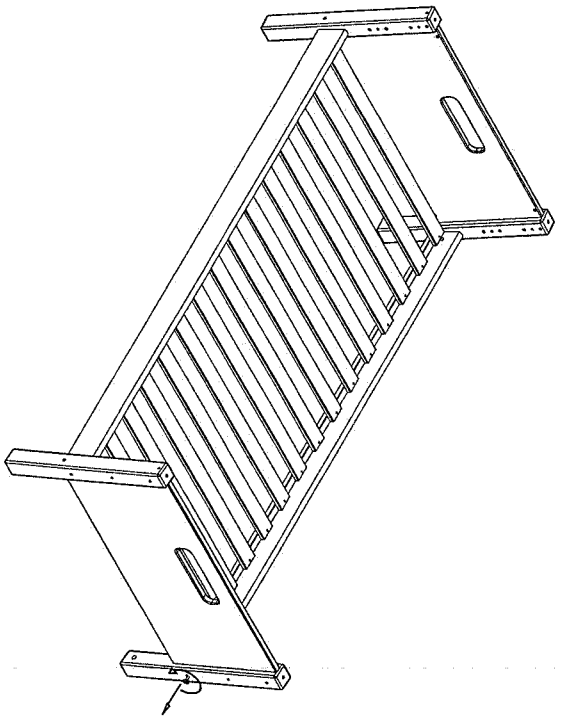

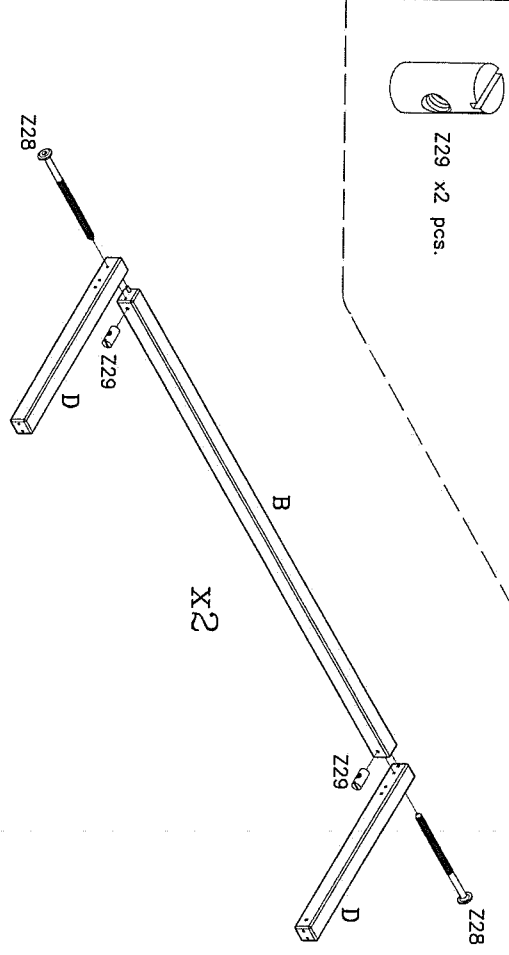
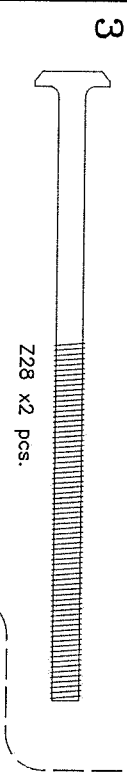
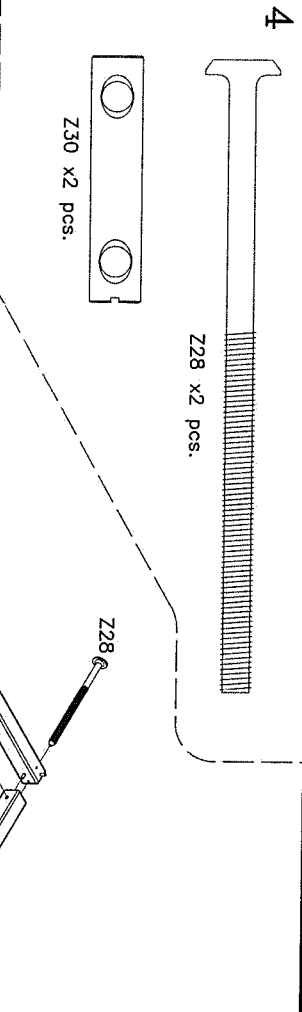
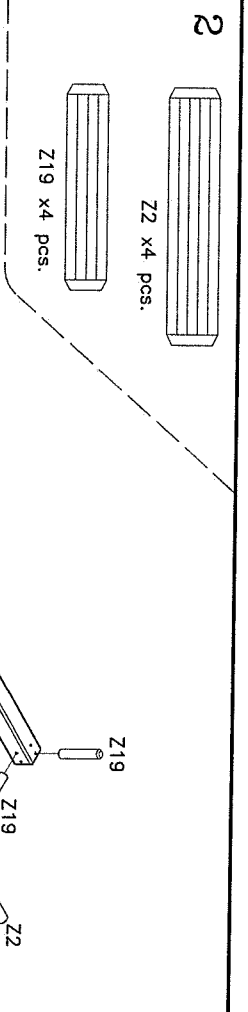
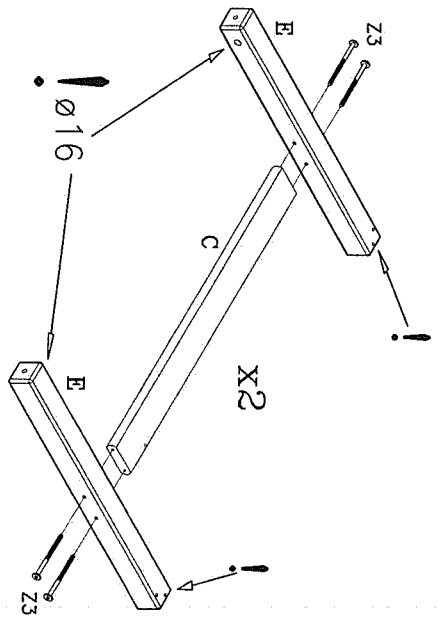
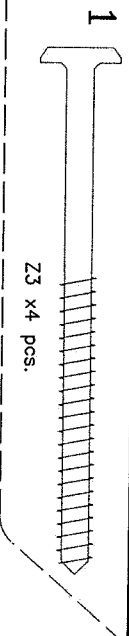

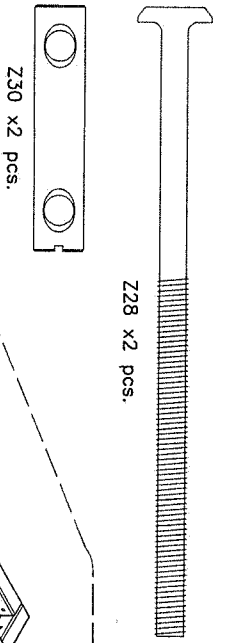

Z28 x2 pcs.

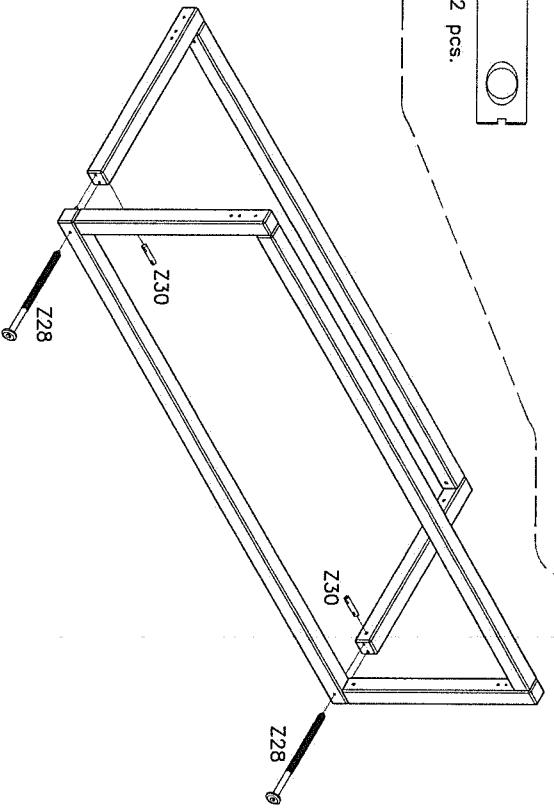

5

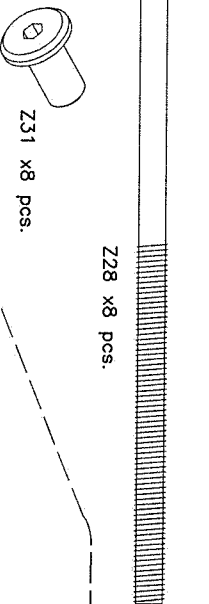

Z28 x8 pcs.

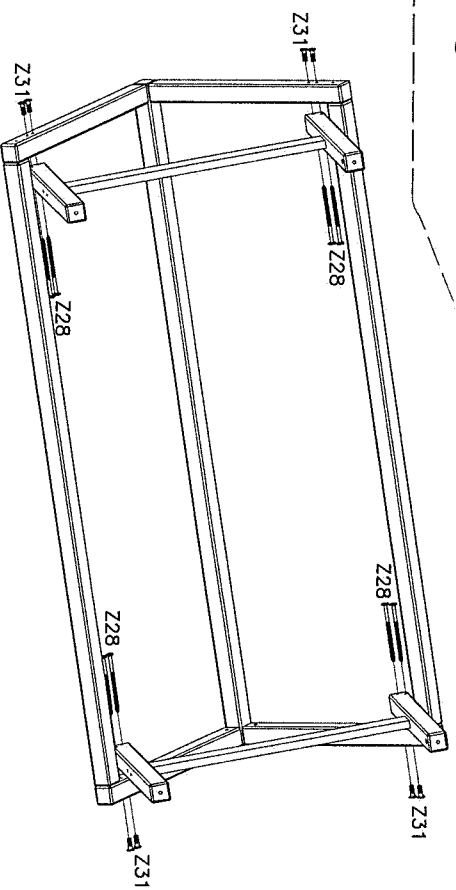

6



Z21 x4 pcs.

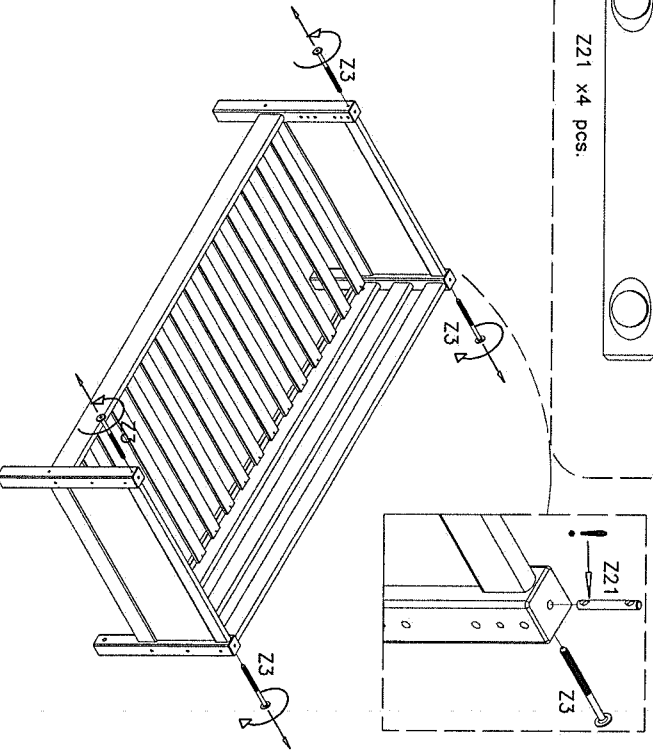

7



Z11 x4 pcs.

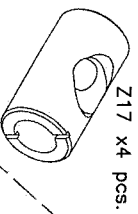

Z17 x4 pcs.

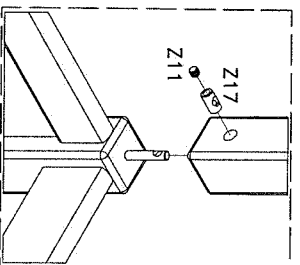

8

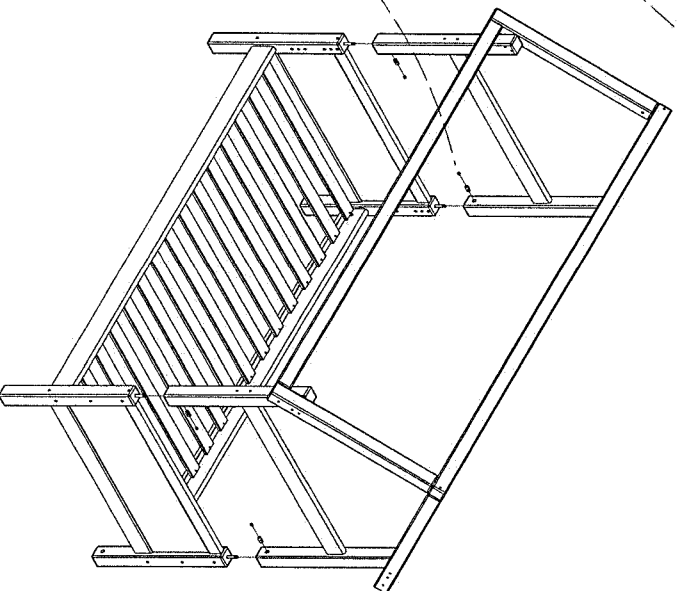

9

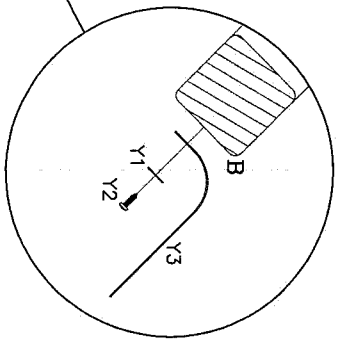
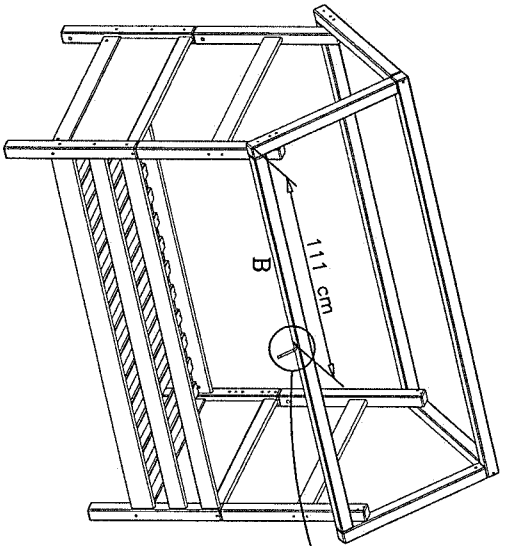
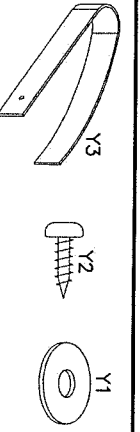

10

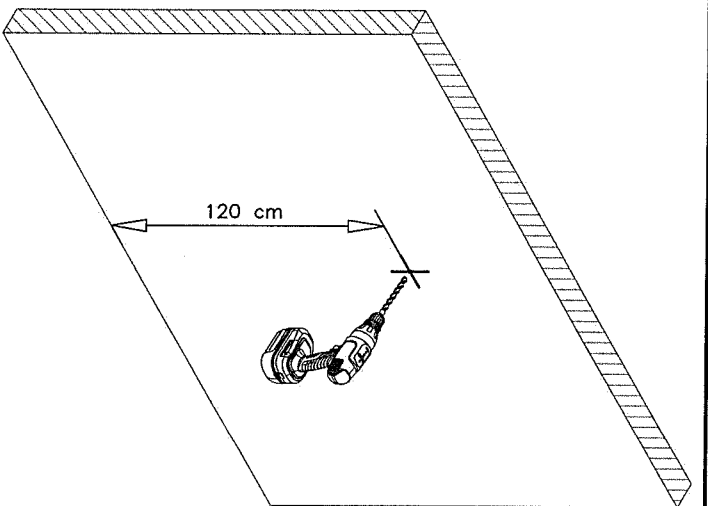

11

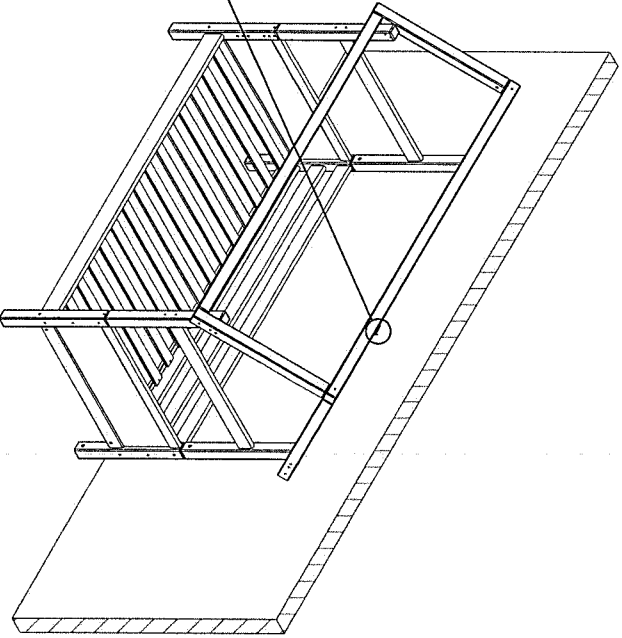
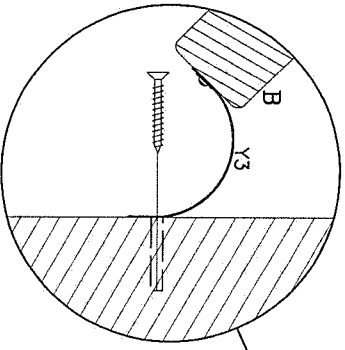

82-20088-40

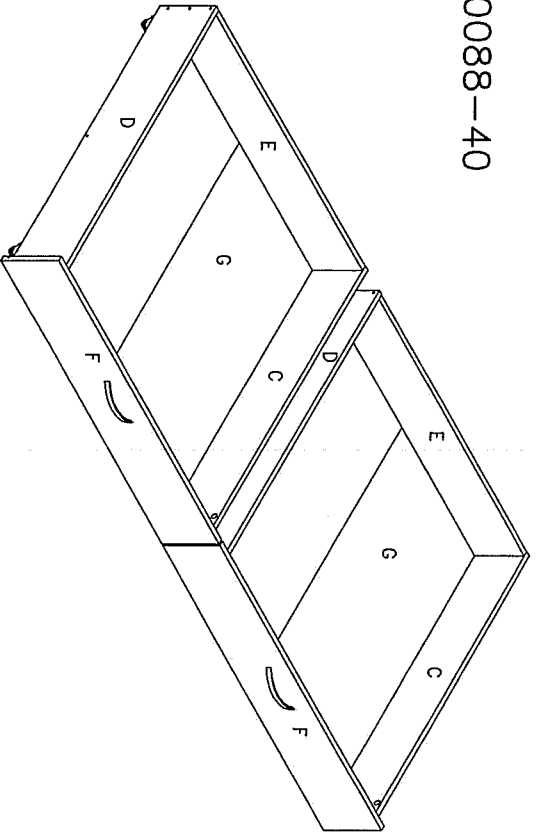

Before assembling this product, please ensure that all the components supplied comply with the list on this page. All Screw-Type fittings can be tightened with this tool.		Avant de commencer l'assemblage, veuillez vérifier que tous les objets indiqués sont présents. Tous les vis peuvent être serrés par cet outil.		Bevor Sie mit dem Aufbau beginnen, kontrollieren Sie ob alle auf der Zeichnung angegebenen Teile vorhanden sind. Bitte verwenden Sie zur Montage einen Kreuzschraubenzieher und den beiliegenden Inmensechschlüssel.		Wart-nr. / Stock no. / Réf. No.		Stück Qty. / Dim.	
12-01508821	2 stick/pcs	15-01508981-40	2 stick/pcs	15-01508821-40	2 stick/pcs	4309-030893			
A	882x65x15 mm	C	898x170x15 mm	E	882x170x15 mm	G	893x892/446x3 mm		
12-01508791-40	2 stick/pcs								
B	879x45x15 mm	D	898x170x15 mm	F	975x172x15 mm				
3901-40040	16 stick/pcs	3901-40060	6 stick/pcs	3902-35015	16 stick/pcs	3903-40035	6 stick/pcs	4001-010	2 stick/pcs
Z1	4.0x40 mm	Z2	4.0x60 mm	Z3	3.5x15 mm	Z4	4.0x35 mm	4003-002	8 stick/pcs
3930-08030	8 stick/pcs	3933-15010	8 stick/pcs	4020-005	8 stick/pcs	3912-04018	4 stick/pcs	Z10	8 stick/pcs
Z5	8x30 mm	Z6	ø15x9.5 mm	Z7	ø7x34 mm	Z8	M4x18 mm	Z9	128 mm

(GB): MAINTENANCE INSTRUCTIONS:

Screws and bolts should from time to time be retightened.
CLEANING:
 Wipe with a clean cloth and a mild soap. Oil: Oiled surfaces should be cleaned with soapy water, e.g. brown soap. To maintain the natural life in the furniture which is provided by the oil treatment, we recommend an oil aftercare of the furniture 1-2 times a year. The colourless natural oil for maintenance of oil-treated furniture is available at your local furniture store.

(D): PFLEGEHINWEIS:

Schrauben und Bolzen sollen regelmäßig nachgezogen werden.
REINIGUNG:
 Lackierte Möbel: Lackierte Holzoberflächen können mit einem sauberen Lappen und mildes Seifenwasser gereinigt werden. Öl: Ölige Oberflächen sollten mit Seifenwasser gereinigt werden. Um den natürlichen Lebenszyklus der Möbel zu erhalten, empfehlen wir eine Öl-Nachbehandlung von Möbelstücken 1 bis 2 Mal pro Jahr empfehlenswert. Das farblose Öl für die Nachbehandlung der Möbel kann in Ihrem Möbelgeschäft gekauft werden.

(F): CONSEILS 'ENTRETIEN':

Votre lit doit être vérifié périodiquement afin de resserrer les vis.
NETTOYAGE:
 LAQUE: Les surfaces bois, laquées, peintes et laminés peuvent être essuyées avec un chiffon et un savon doux. HUILE: Des surfaces huilées peuvent être nettoyées avec l'eau savonneuse. Pour maintenir l'aspect naturel du bois/pour vous recommandons une huile incolore d'entretien 1-2 fois par an. L'huile naturelle sans colorant peut être achetée dans votre magasin de meubles.

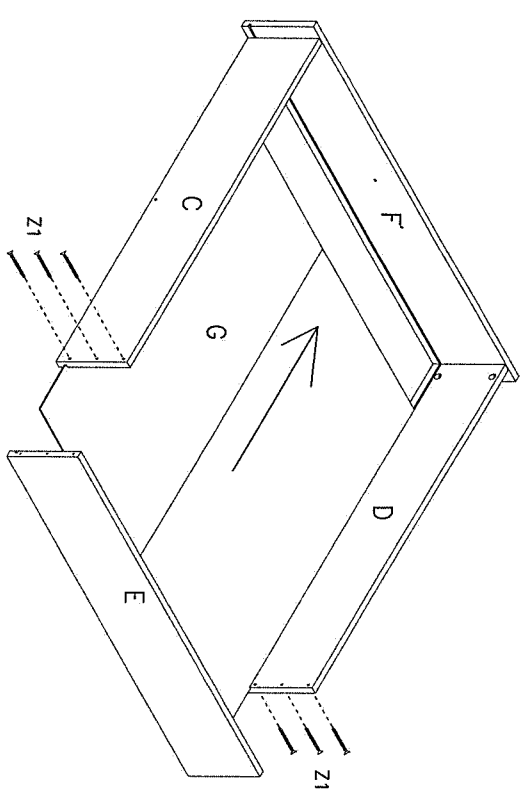
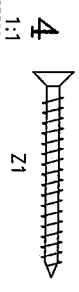
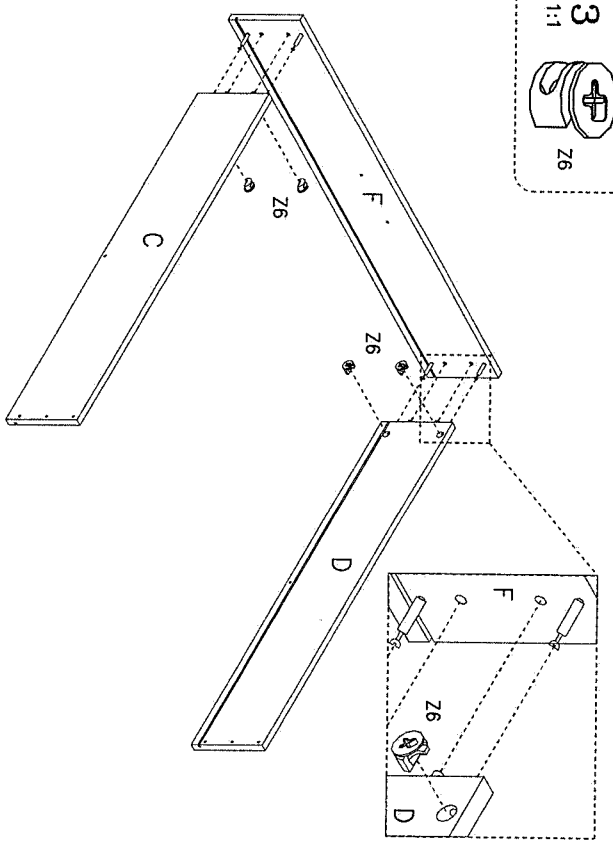
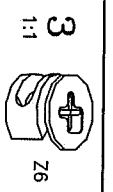
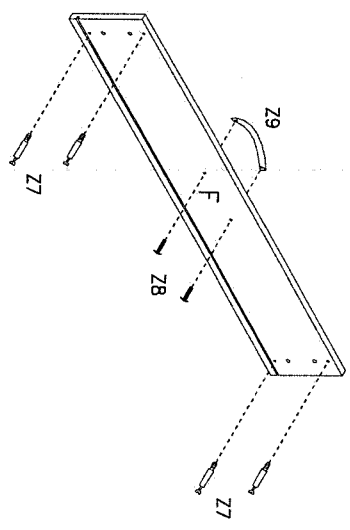
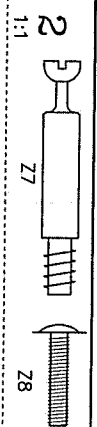
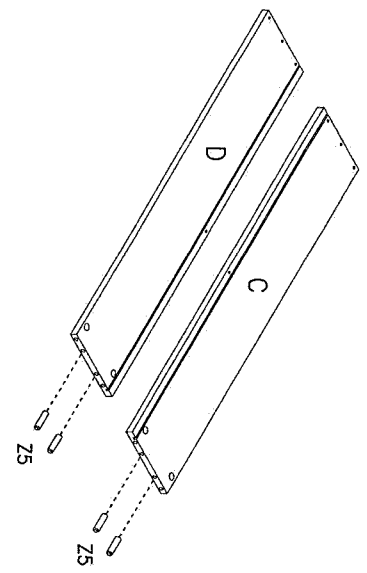

5

