

# 80-20101-40

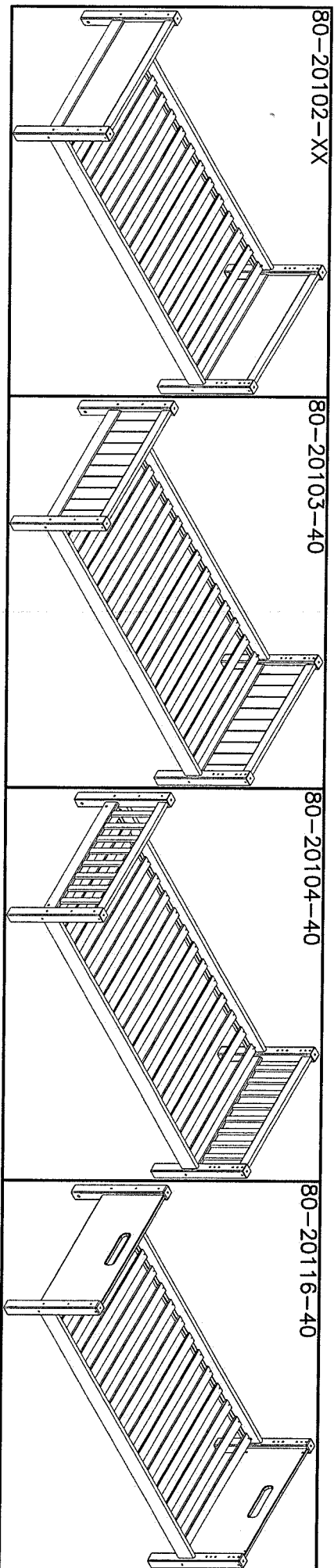

See assembly instruction in box no.  
 Voir notice de montage dans la caisse no.  
 Siehe Aufbauanleitung im Karton no.  
 Zie voor de montage-instructie pakketnr.

**Before assembling this product, please ensure that all the components supplied comply with the list on this page. All Screw-Type fittings can be tightened with this tool.**

**Avant de commencer l'assemblage, veuillez contrôler si tous les objets indiqués sont présents. Tous les vis peuvent être serrés par cet outil.**

**Bevor Sie mit dem Aufbau beginnen, kontrollieren Sie ob alle auf der Zeichnung angegebenen Teile vorhanden sind. Bitte verwenden Sie zur Montage einen Kreuzschraubzieher und den beiliegenden Inbenschlüssel.**

**Ware-nr. Part no. Ref No.**

**Stück. Qty. Ote.**

**Mass Dim. Dim.**

12-06306473-40 2 stick/pcs. 12-06306474-40 2 stick/pcs. 1305-19672-40 2 stick/pcs.

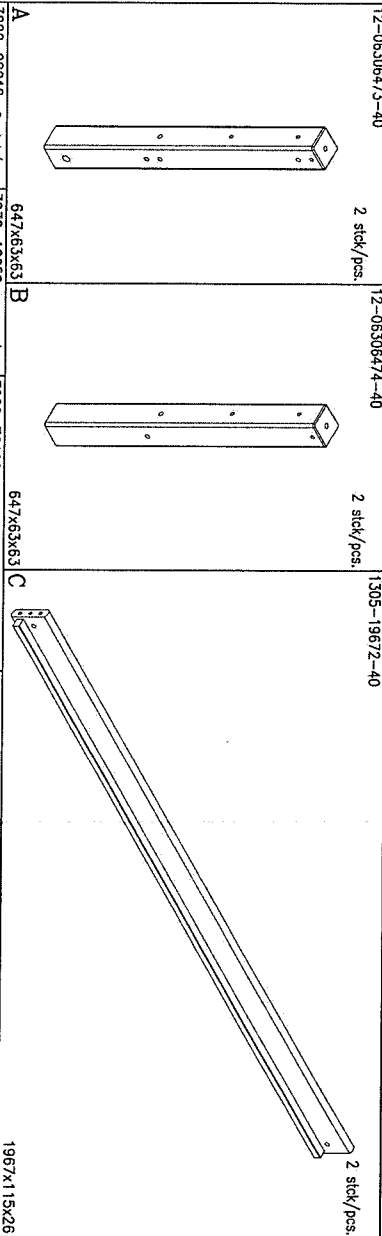

**A** 3922-08018 8 stick/pcs. 547x63x63 **B** 3930-10050 16 stick/pcs. 3909-70100 647x63x63 **C** 4 stick/pcs. 3901-40030 30 stick/pcs. 1967x115x26

**Z1** M8/ø12x18 mm. **Z2** ø10x50 mm. **Z3** ø7x100 mm. **Z4** 3938-00016-2 4 stick/pcs. 4033-005 1 stick/pcs.

3913-08110 8 stick/pcs. 3938-000081-2 16 stick/pcs. 3938-00010-2 20 stick/pcs. 3938-00016-2 4 stick/pcs. 4033-005 1 stick/pcs.

**Z5** M8x110 mm. **Z6** ø8 mm. **Z7** ø10 mm. **Z8** ø16 mm.

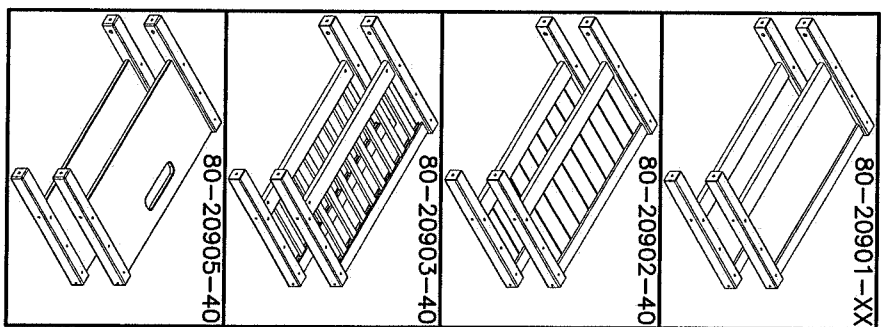

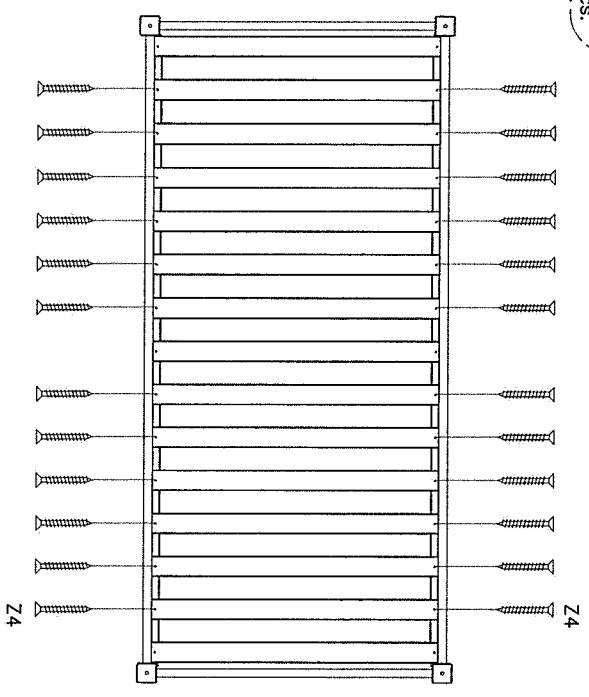
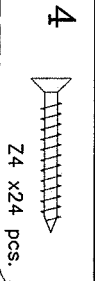
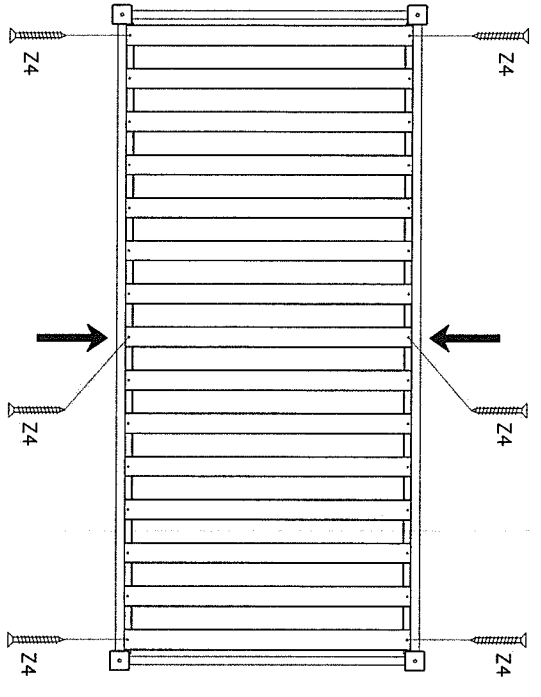
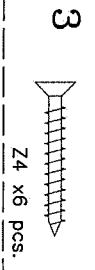
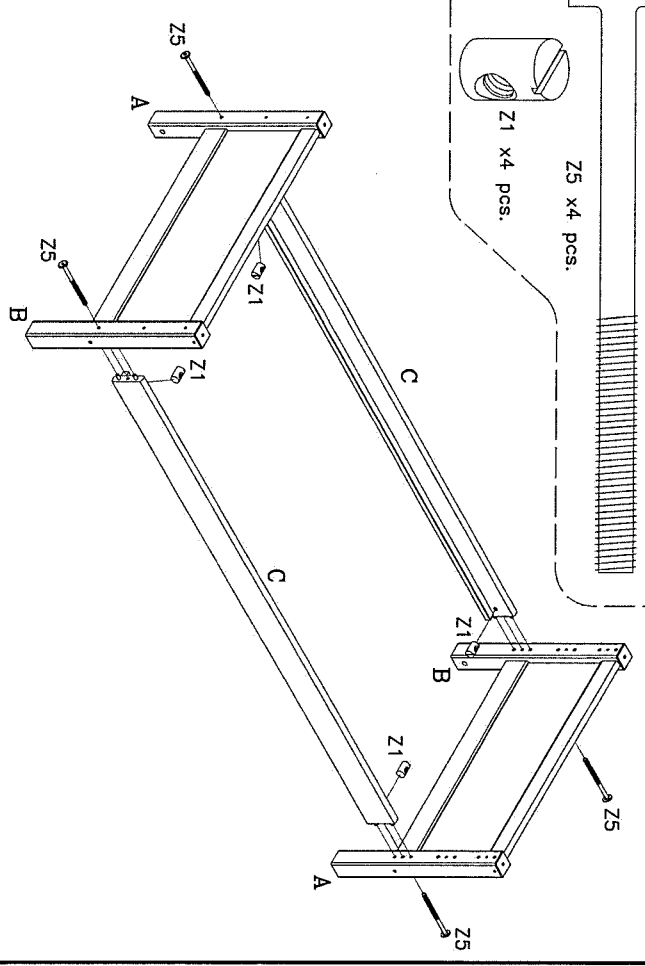
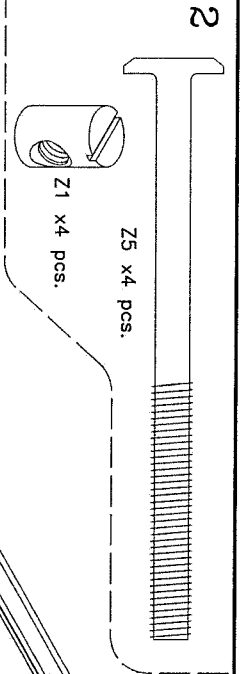
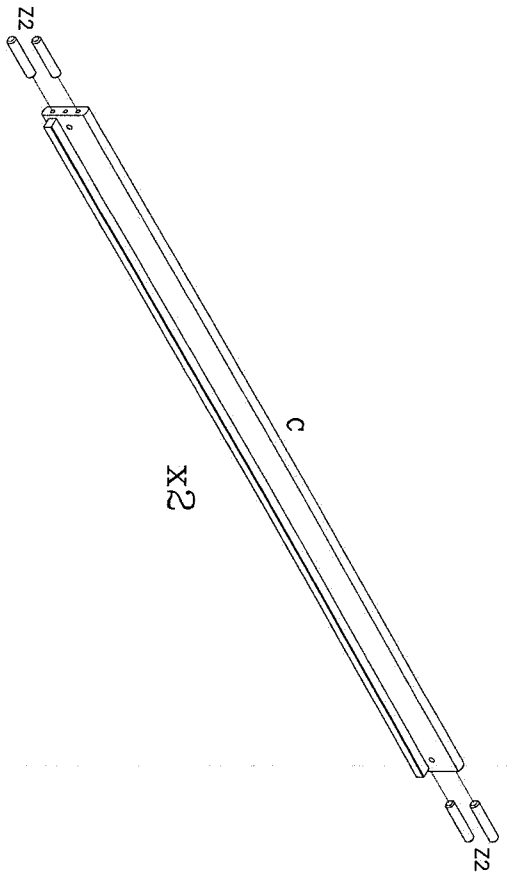
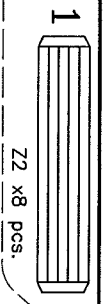

# 80-20905-40 White

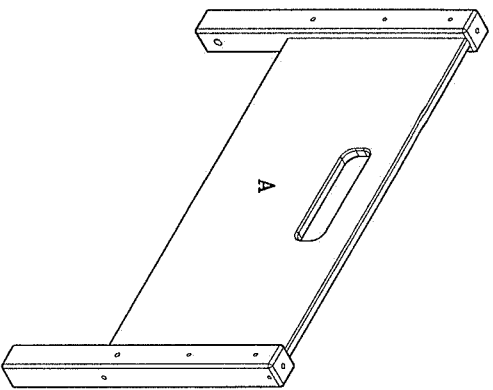

|   |   |   |   |                                 |
|---|---|---|---|---------------------------------|
| <p>Before assembling this product, please ensure that all the components supplied with the cartons are present. All screws and fittings must be tightened with this tool.</p> | <p>Avant de commencer l'assemblage, veuillez contrôler si tous les objets indiqués sont présents. Tous les vis peuvent être serrés par cet outil.</p> | <p>Bevor Sie mit dem Aufbau beginnen, kontrollieren Sie ob alle auf der Zeichnung angegebenen Teile vorhanden sind. Bitte verwenden Sie zur Montage einen Kreuzschraubenzieher und den Innensechskantschlüssel.</p> | <p>Ware-nr.<br/>Part. no.<br/>Réf. No.</p>              | <p>Stück.<br/>Qty.<br/>Qté.</p> |
| <p>4301-2208631-40</p>  | <p>2 stick/pcs.</p>   |   | <p>Bitte Bild-nr.<br/>See picture no.<br/>Image no.</p> | <p>Mass<br/>Dim.<br/>Dim.</p>   |

|                   |                   |                     |                   |                    |                     |                 |                     |              |
|-------------------|-------------------|---------------------|-------------------|--------------------|---------------------|-----------------|---------------------|--------------|
| <p>863x431x22</p> | <p>Z228</p>       | <p>3922-060181</p>  | <p>3913-06110</p> | <p>M6/Ø10x18mm</p> | <p>4 stick/pcs.</p> | <p>4033-004</p> | <p>1 stick/pcs.</p> | <p>4 mm.</p> |
| <p>A</p>          | <p>M6x110 mm.</p> | <p>4 stick/pcs.</p> | <p>4 mm.</p>      | <p>4 mm.</p>       | <p>4 mm.</p>        | <p>4 mm.</p>    | <p>4 mm.</p>        | <p>4 mm.</p> |

Z1, Z2, Z5 Fittings in single / bunk bed box.  
 Z1, Z2, Z5 Beschläge im Einzel- / Etagenbett Karton.  
 Z1, Z2, Z5 Raccords en lit simple / lit superposé.  
 Z1, Z2, Z5 Fittings in het enkelespel / stapelbed boxen.

|                  |                  |                  |
|------------------|------------------|------------------|
| <p><b>1</b></p>  | <p><b>2a</b></p> | <p><b>2b</b></p> |
| <p><b>3a</b></p> | <p><b>3b</b></p> | <p><b>3a</b></p> |
| <p><b>3a</b></p> | <p><b>3b</b></p> | <p><b>3b</b></p> |

Bunk bed only. Nur Etagen Bett.  
 Lits superposés seulement. Alleen stapelbed

# 80-20401-40

80-20403-XX

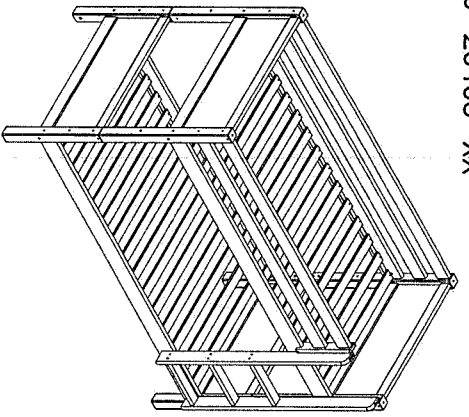

80-20404-40

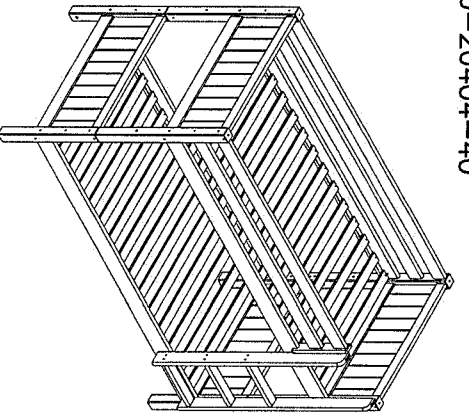

80-20405-40

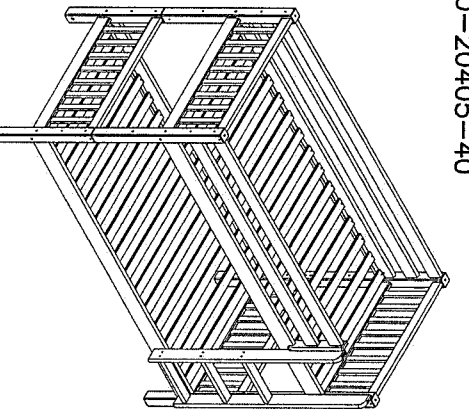

Before assembling this product, please ensure that all the components supplied comply with the list on this page. All Screw-Type fittings can be tightened with this tool.

Avant de commencer l'assemblage, veuillez vérifier que tous les objets indiqués sont présents. Tous les vis peuvent être serrés par cet outil.

Bevor Sie mit dem Aufbau beginnen, kontrollieren Sie ob alle auf der Zeichnung angegebenen Teile vorhanden sind. Bitte verwenden Sie zur Montage einen Kreuzschraub-zieh- und den beiliegenden Innesschraubenschlüssel.



| Werte-nr.<br>Part no.<br>Ref. No.               | Stück-<br>Qty.<br>Qté. |
|---|------------------------|
| Stärke Bild-nr.<br>See picture no.<br>Image no. | Mess-<br>Dim.          |

|                |              |                |              |                |              |                |              |
|----------------|--------------|----------------|--------------|----------------|--------------|----------------|--------------|
| 12-02603182-40 | 3 stick/pcs. | 12-02612641-40 | 2 stick/pcs. | 12-02619676-40 | 2 stick/pcs. | 12-06308655-40 | 2 stick/pcs. |
|----------------|--------------|----------------|--------------|----------------|--------------|----------------|--------------|

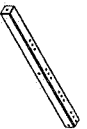
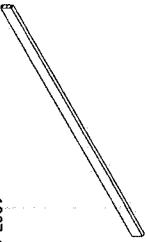
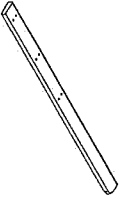
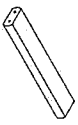

|                |              |                |              |                |              |                |              |
|----------------|--------------|----------------|--------------|----------------|--------------|----------------|--------------|
| 12-02603611-40 | 1 stick/pcs. | 12-02615712-40 | 2 stick/pcs. | 12-05-19672-40 | 2 stick/pcs. | 12-06308655-40 | 2 stick/pcs. |
|----------------|--------------|----------------|--------------|----------------|--------------|----------------|--------------|

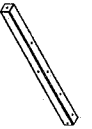
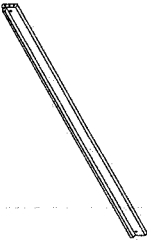
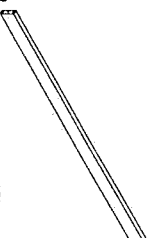
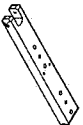

|           |            |            |           |
|-----------|------------|------------|-----------|
| 318x65x26 | 1284x89x26 | 1967x89x26 | 865x63x63 |
|-----------|------------|------------|-----------|

|            |              |            |               |            |               |            |               |            |              |            |              |            |              |
|------------|--------------|------------|---------------|------------|---------------|------------|---------------|------------|--------------|------------|--------------|------------|--------------|
| 3922-08018 | 8 stick/pcs. | 3930-10050 | 32 stick/pcs. | 3909-70100 | 10 stick/pcs. | 3901-40030 | 40 stick/pcs. | 3913-08110 | 8 stick/pcs. | 3903-40025 | 2 stick/pcs. | 3907-63022 | 2 stick/pcs. |
|------------|--------------|------------|---------------|------------|---------------|------------|---------------|------------|--------------|------------|--------------|------------|--------------|

|           |            |             |           |
|-----------|------------|-------------|-----------|
| 361x65x26 | 1571x89x26 | 1967x115x26 | 865x63x63 |
|-----------|------------|-------------|-----------|

|              |           |           |          |           |       |          |            |
|--------------|-----------|-----------|----------|-----------|-------|----------|------------|
| M8/ø12x18 mm | ø10x50 mm | ø7x100 mm | ø4x30 mm | M8x110 mm | ø8 mm | ø4x25 mm | ø6.3x22 mm |
|--------------|-----------|-----------|----------|-----------|-------|----------|------------|

|          |              |          |              |            |               |            |              |            |              |            |              |
|----------|--------------|----------|--------------|------------|---------------|------------|--------------|------------|--------------|------------|--------------|
| 4007-014 | 4 stick/pcs. | 4008-021 | 2 stick/pcs. | 3909-70060 | 14 stick/pcs. | 3901-30020 | 4 stick/pcs. | 3908-70050 | 4 stick/pcs. | 3934-10080 | 4 stick/pcs. |
|----------|--------------|----------|--------------|------------|---------------|------------|--------------|------------|--------------|------------|--------------|

|    |    |    |    |    |    |    |    |    |     |     |
|----|----|----|----|----|----|----|----|----|-----|-----|
| Z1 | Z2 | Z3 | Z4 | Z5 | Z6 | Z7 | Z8 | Z9 | Z10 | Z11 |
|----|----|----|----|----|----|----|----|----|-----|-----|

See assembly instruction in box no. 80-20101-40

Voir notice de montage dans la coisse no. 80-20101-40

Siehe Aufbauanleitung im Karton no. 80-20101-40

Zie voor de montage-instructie pakketnr. 80-20101-40

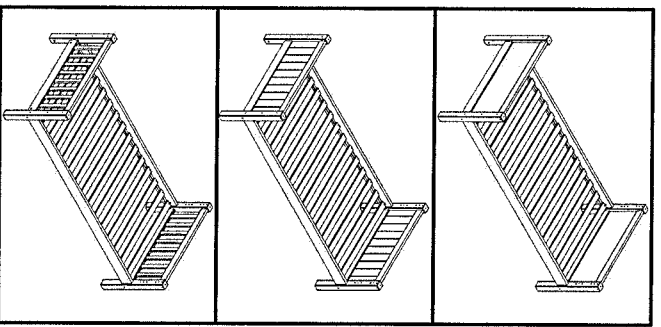

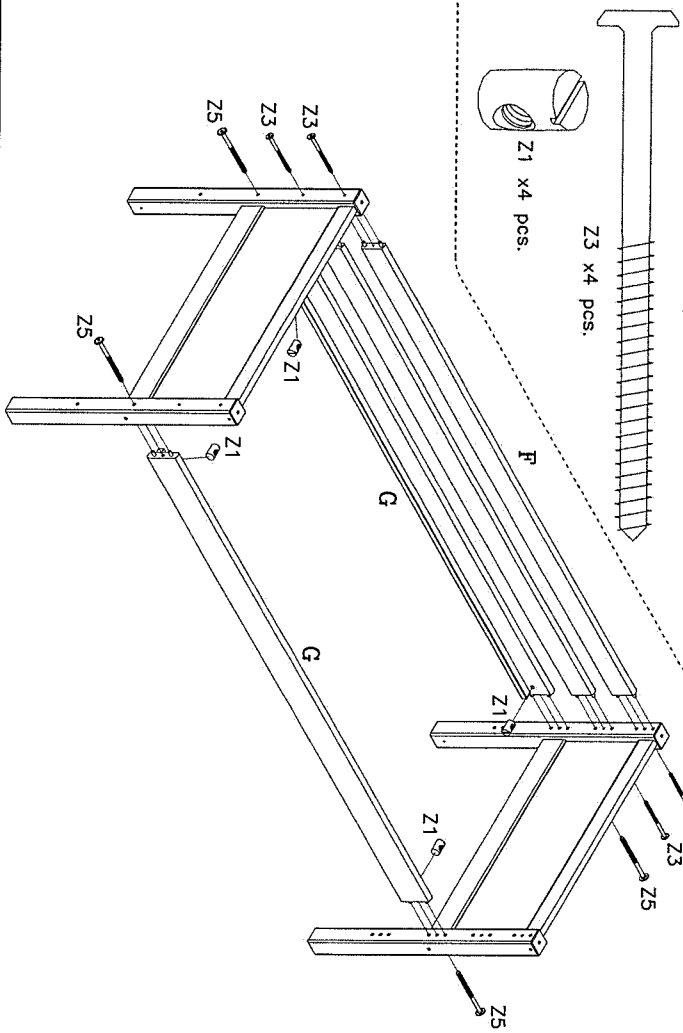
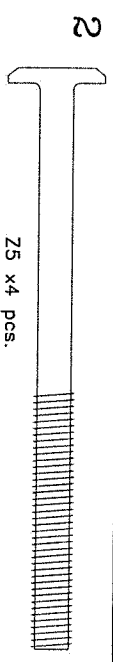
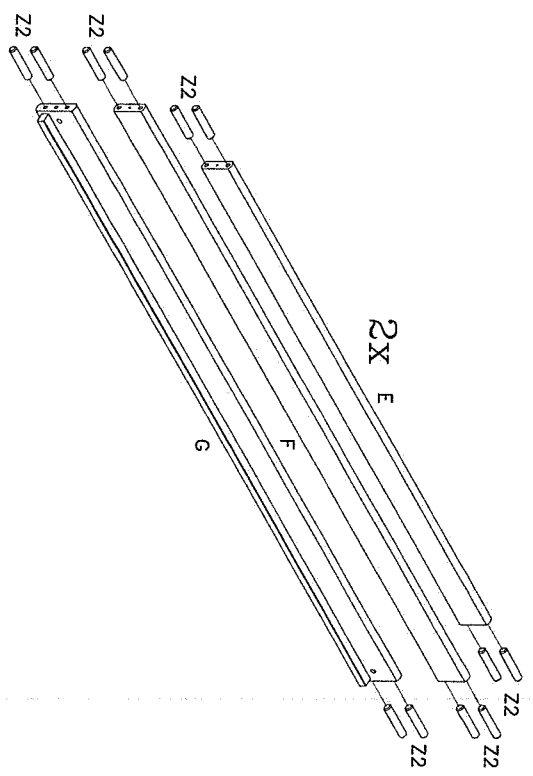

3

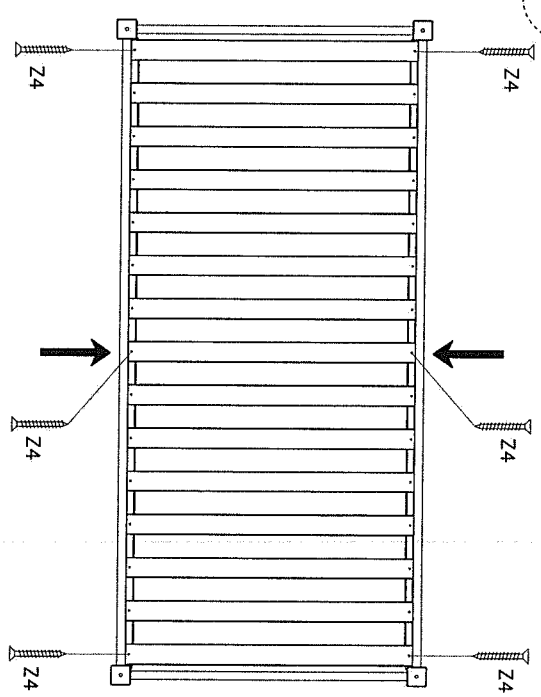
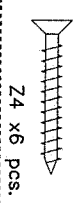

4

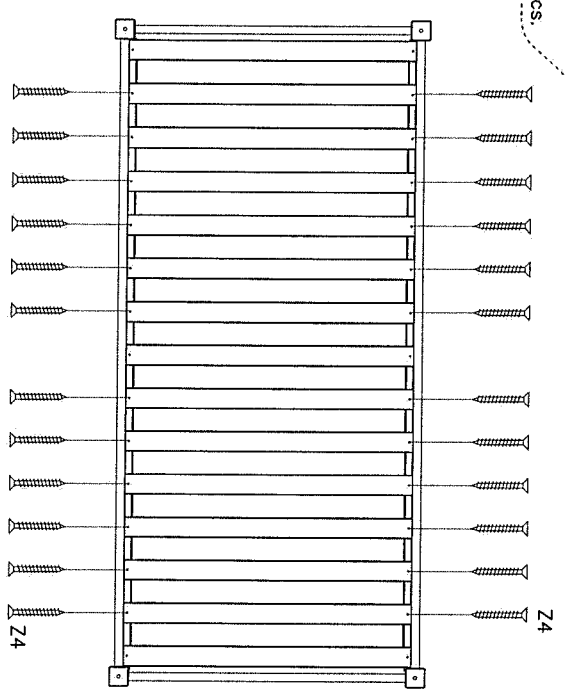
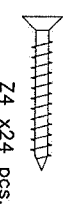

5



Z21 x4 pcs.

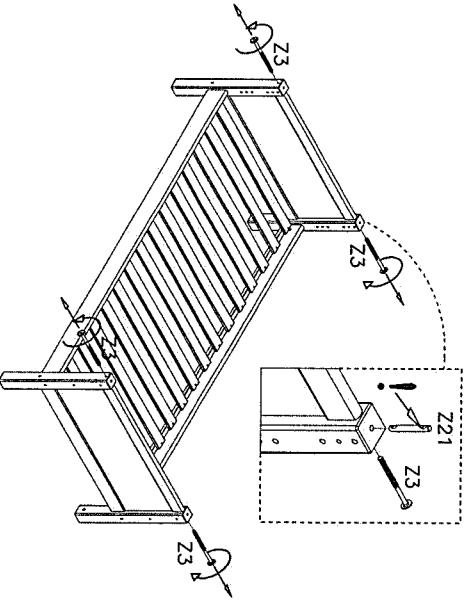

6



Z20 x4 pcs.

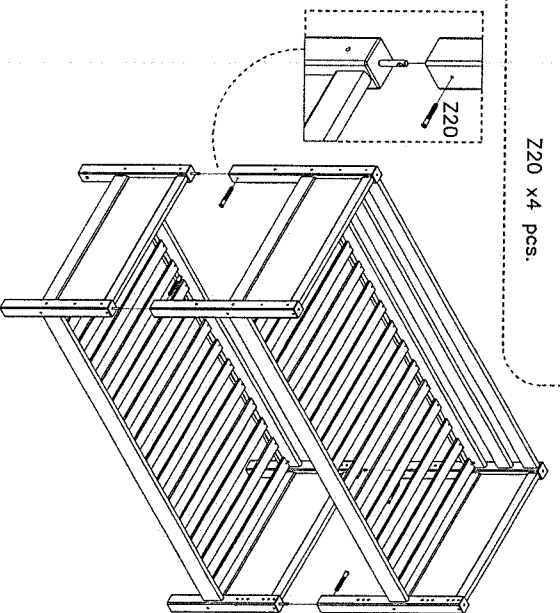

7

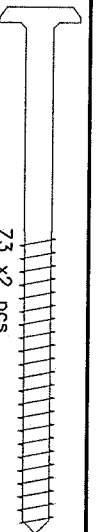

Z3 x2 pcs.

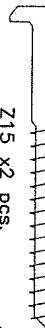

Z15 x2 pcs.

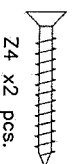

Z4 x2 pcs.

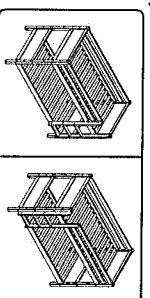

8

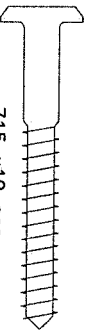

Z15 x12 pcs.

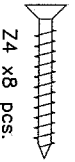

Z4 x8 pcs.

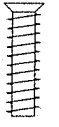

Z10 x2 pcs.



Z13 x2 pcs.

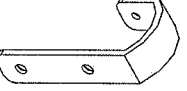

Z12 x4 pcs.

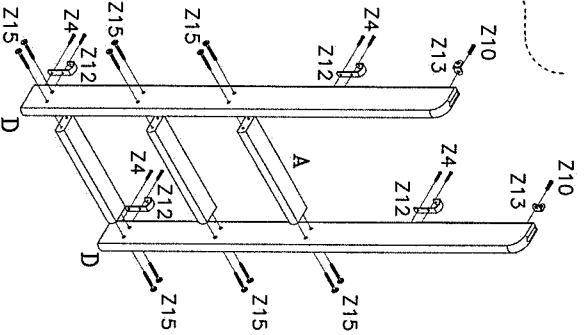

9

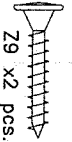

Z9 x2 pcs.

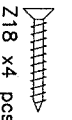

Z18 x4 pcs.

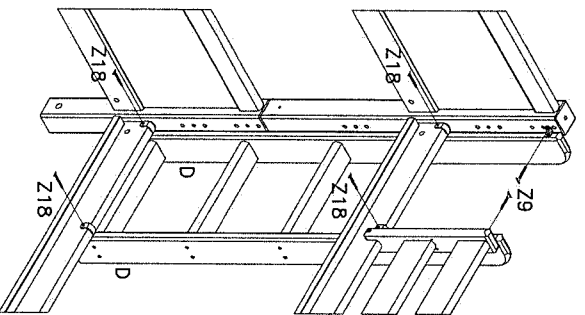

DK: Max. madrashøjde  
 D: Max. Höhe der Matratze  
 GB: Max. height of mattress  
 F: Hauteur max. du matelas  
 I: Altezza max. materasso  
 E: Altura del colchón máximo  
 NL: Maximale matrashoogte  
 CN: 床垫最大高度

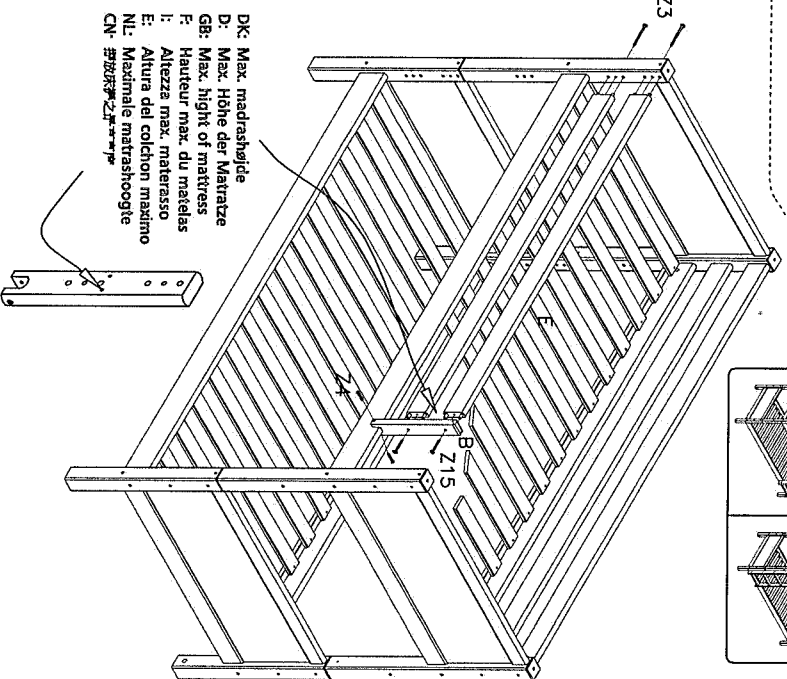

Bunk bed as 2 single beds.

Etagenbett als 2 Einzelbetten.

Comme 2 lits simple.

Stapelbed gemaakt in 2  
 eenpersoonsbedden.

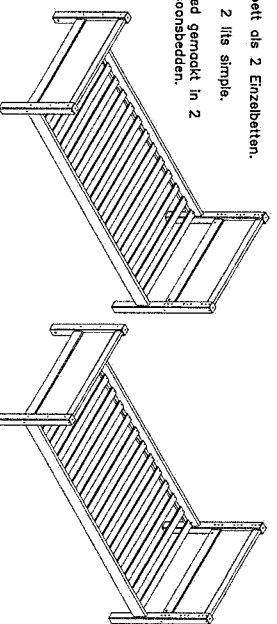









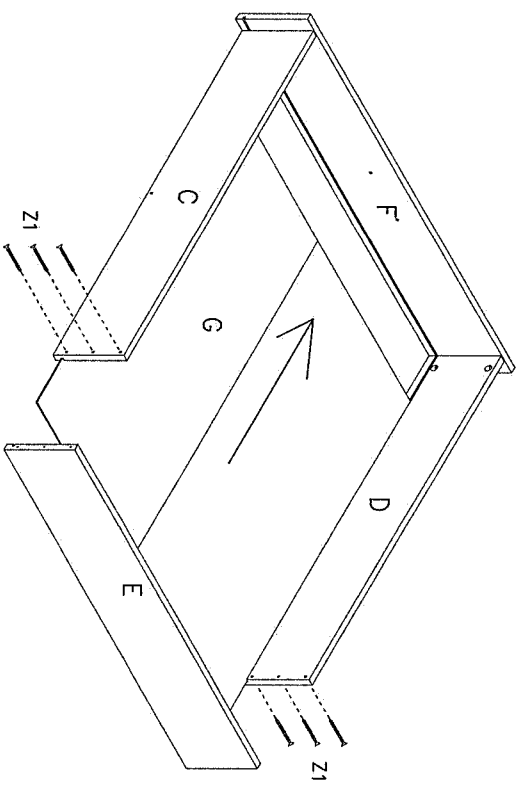
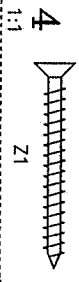
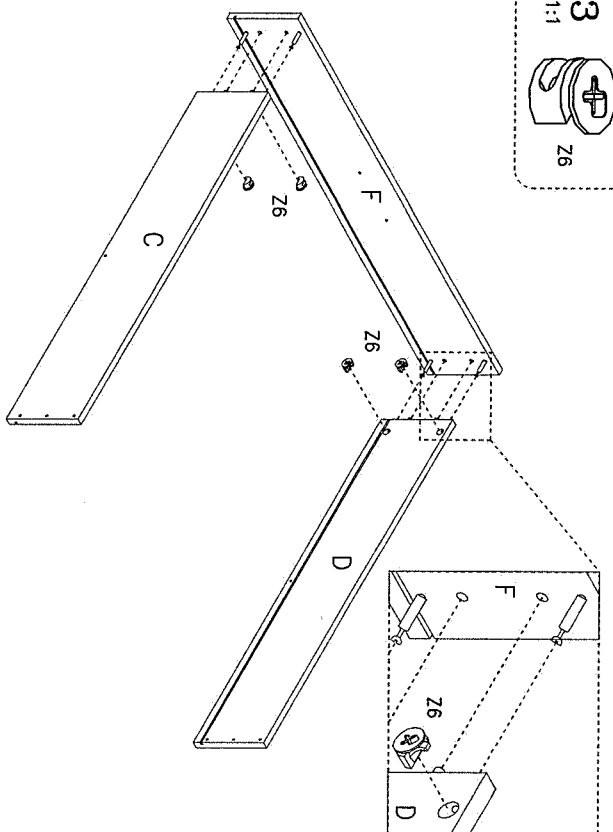
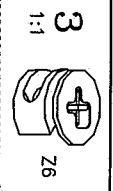
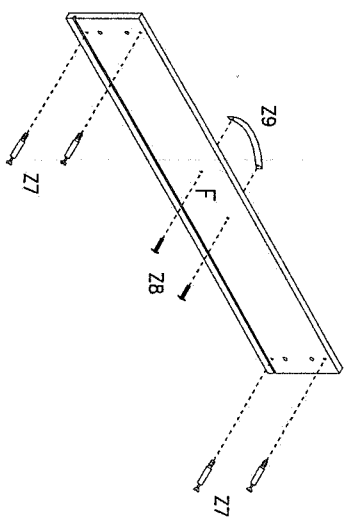
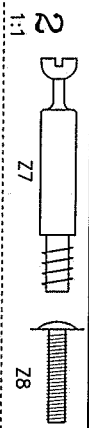
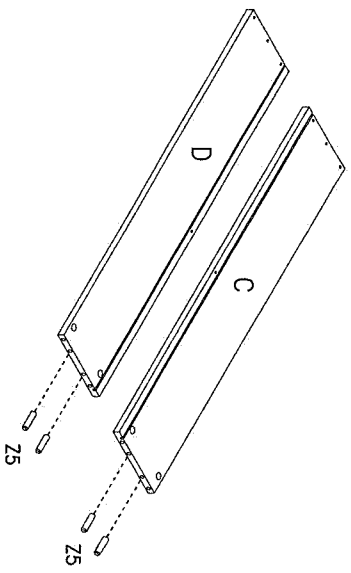

5

