

**(D)** Montageanleitung.

**(FR)** Notice de montage

**(NL)** Handleiding voor de montage

**(CZ)** Montážní návod

**(HU)** Szerelési útmutató

**(TR)** Montaj talimatı

**(GB)** Assembly instructions

**(IT)** Istruzioni di montaggio

**(PL)** Instrukcja montażu

**(SK)** Návod na montáž

**(RO)** Instrucțiuni de montaj

**(RU)** Инструкция по монтажу

**(EST)** Montaažijuhend

Reference no/Batch code :

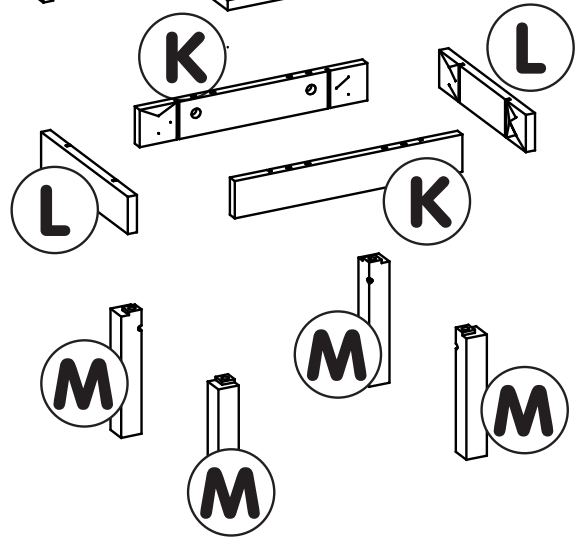
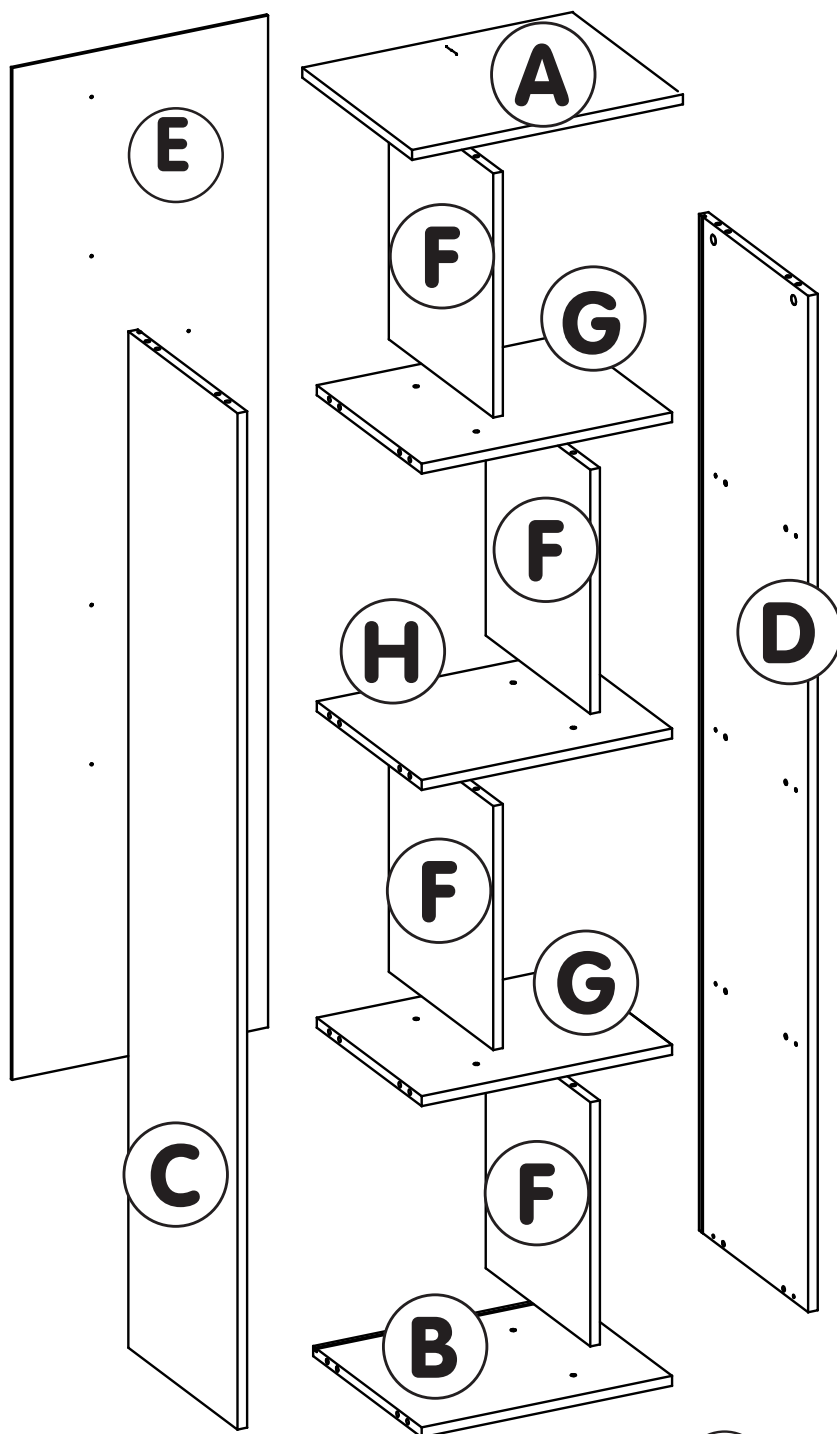







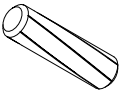

ENG - In case of any quality issues, contact your local dealer and always mention item reference No.

FR - En cas de problèmes de qualité, contactez votre revendeur local et mentionnez toujours la référence de l'article.

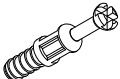
IT - In caso di eventuali problemi di qualità, contattare il rivenditore locale e citare sempre punto di riferimento No.

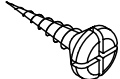
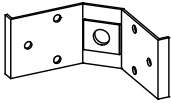
ES - En caso de problemas de calidad, póngase en contacto con su distribuidor local y mencione siempre la referencia del artículo.

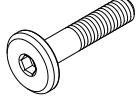
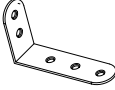
DE - Wenn Sie Qualitätsprobleme haben wenden Sie sich bitte an ihren örtlichen Händler und erwähnen Sie immer die Artikelnummer.

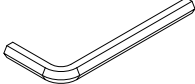
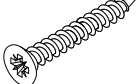
<b>A1</b>		x40 8x 35 mm	<b>A2</b>		x24	<b>A3</b>		x24
<b>A4</b>		x12 BLACK	<b>A5</b>		x4 OAK	<b>A6</b>		x24 Ø3,5x16
<b>A7</b>		x4 90x40x1,5	<b>A8</b>		x4 M6 x10x20 mm	<b>A9</b>		x4 M6 x 35 mm
<b>A10</b>		x1	<b>A11</b>		x2 3,5 x 15 mm	<b>A12</b>		x4 28 mm
<b>A13</b>		x1 4 mm	<b>A14</b>		x8 3 x 20 mm	<b>A15</b>		

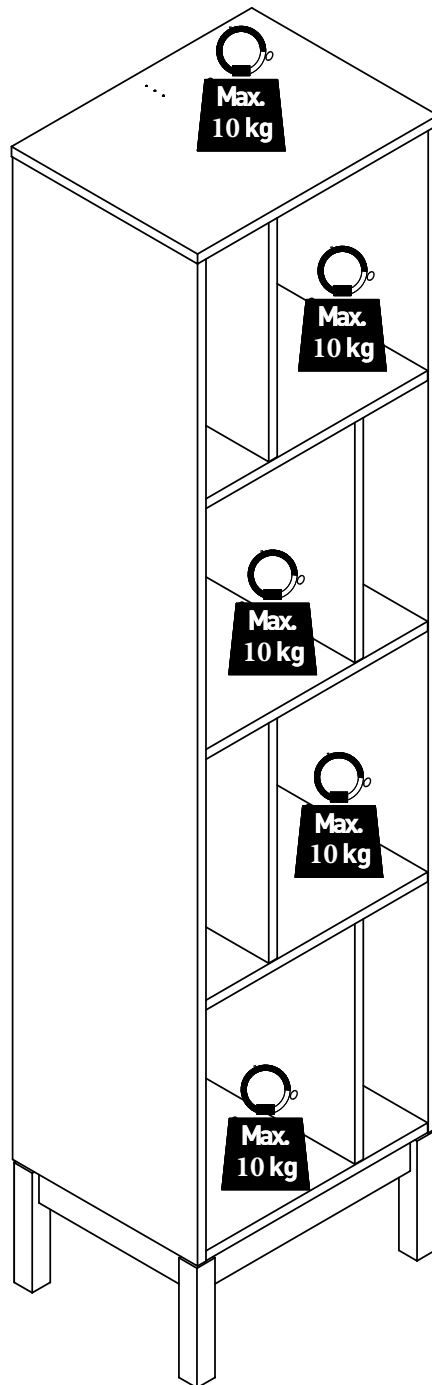

**1**

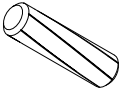
**A1**  **x16**  
**8x 35 mm**

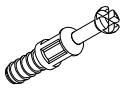
**A3**  **x4**

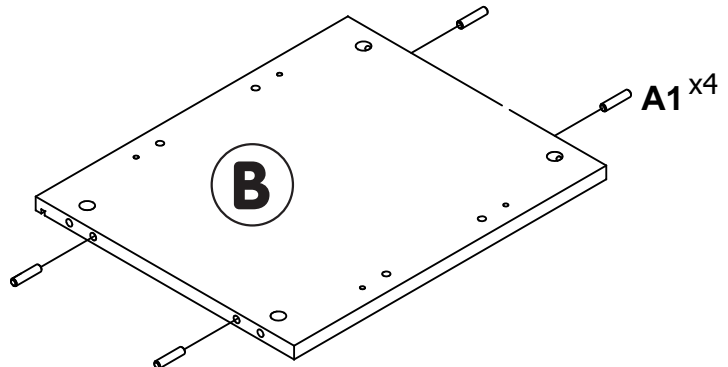
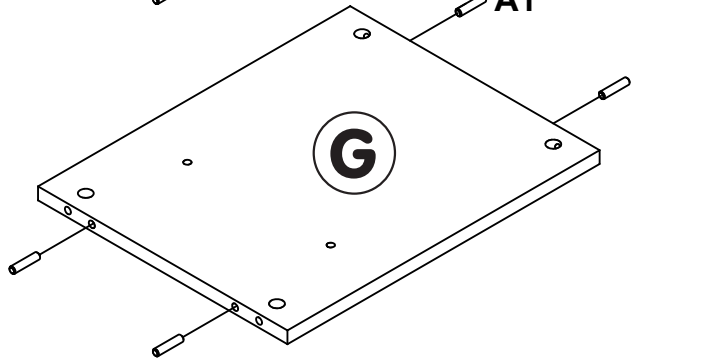
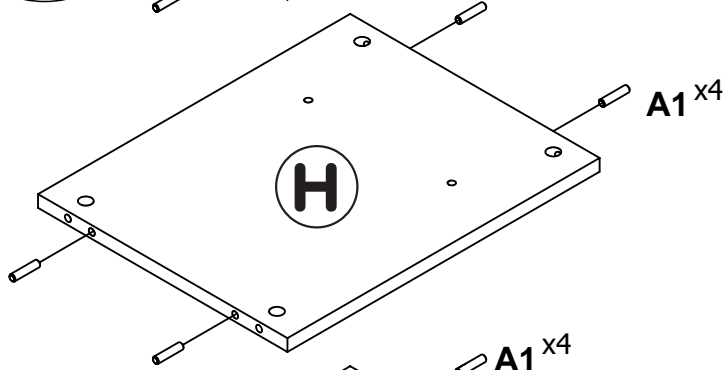
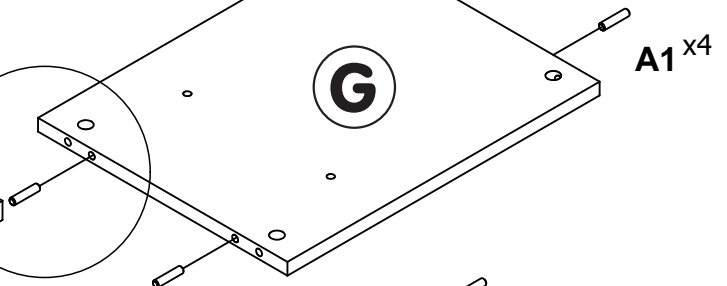
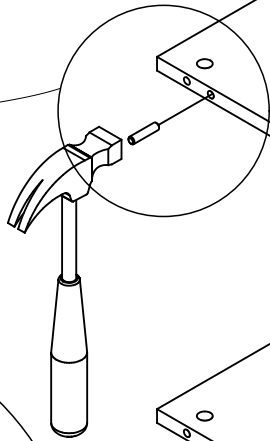
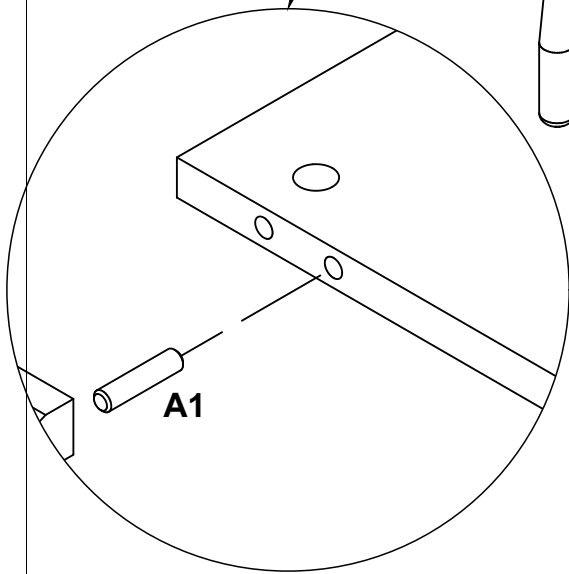
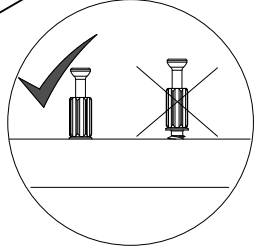
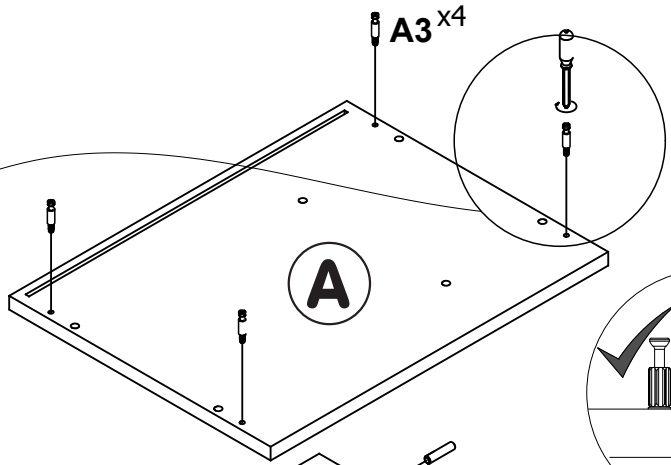
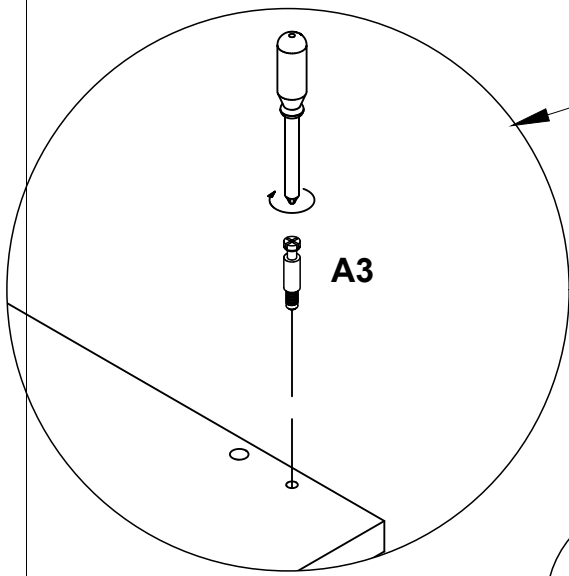

2

A1 x24  
8x 35 mm

A3 x16



+

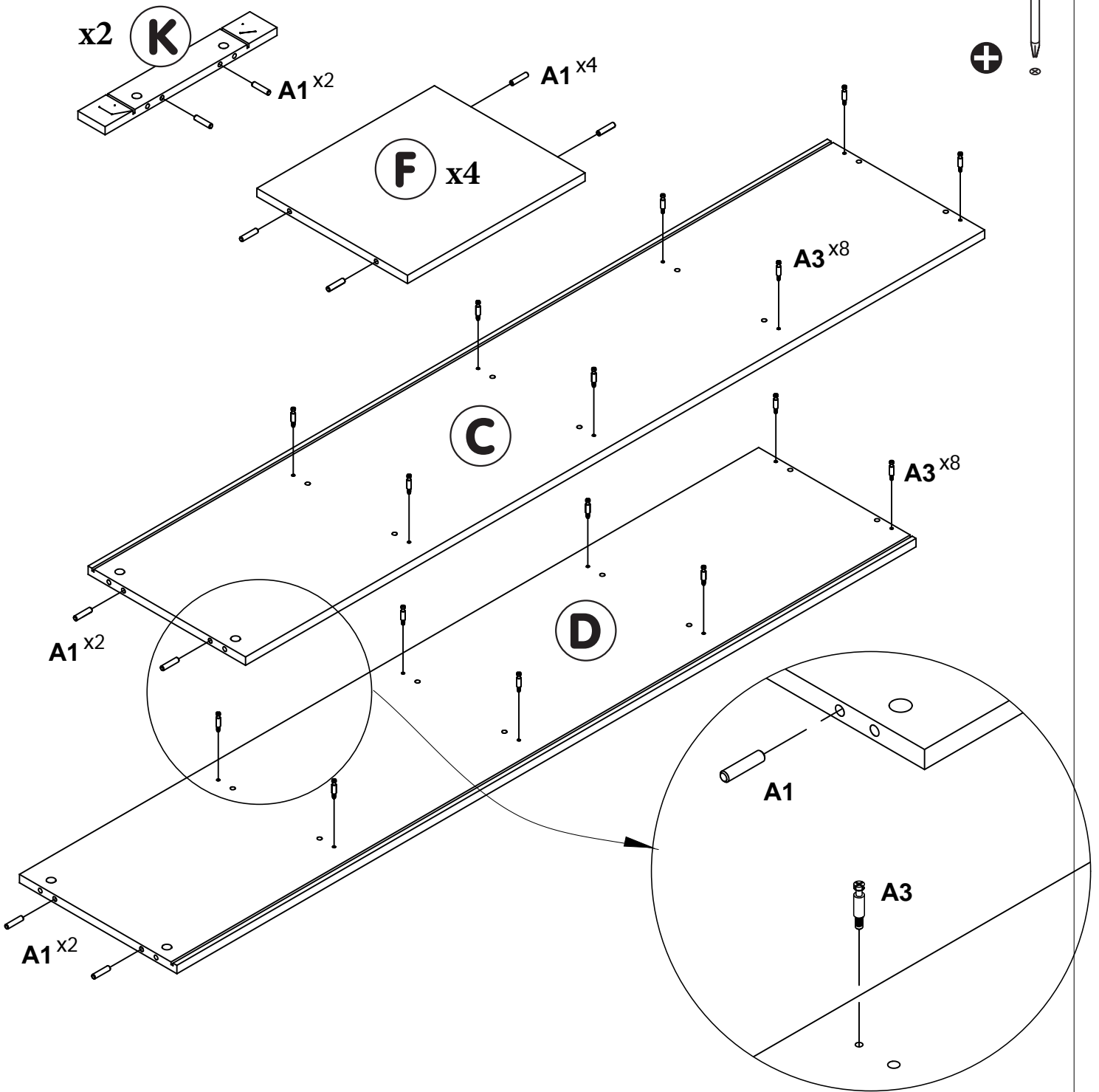

3

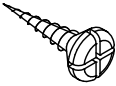
**A6**  x24  
Ø3,5x16

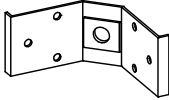
**A7**  x4  
90x40x1,5

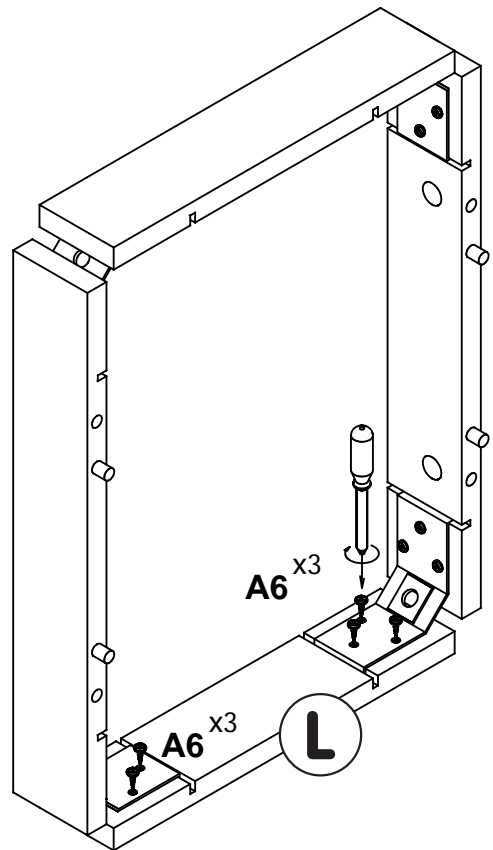
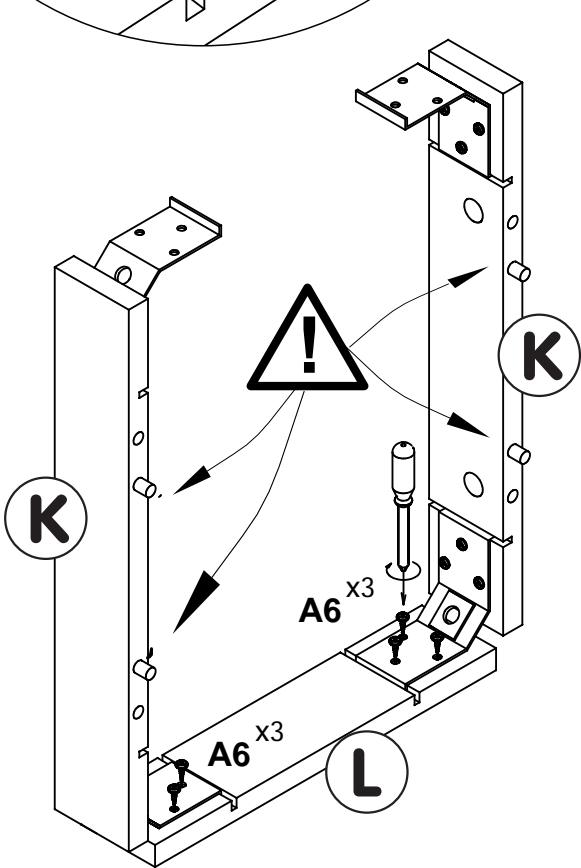
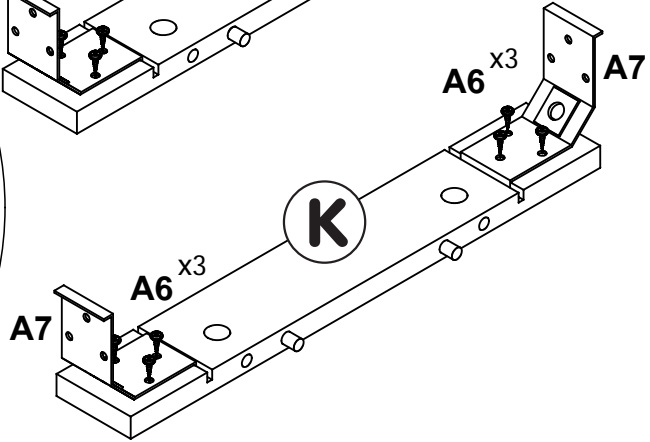
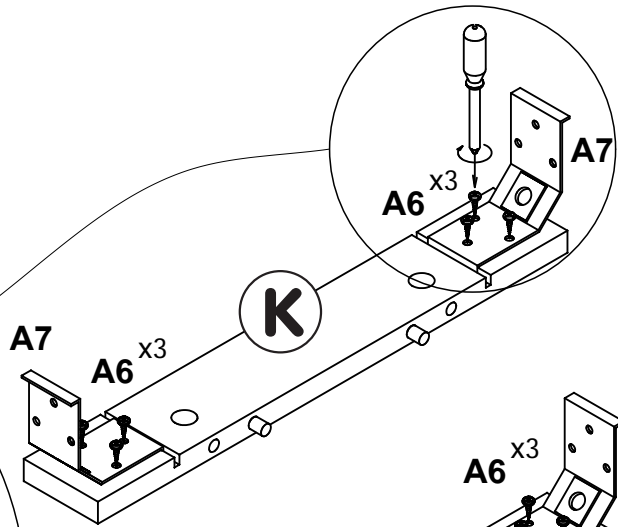
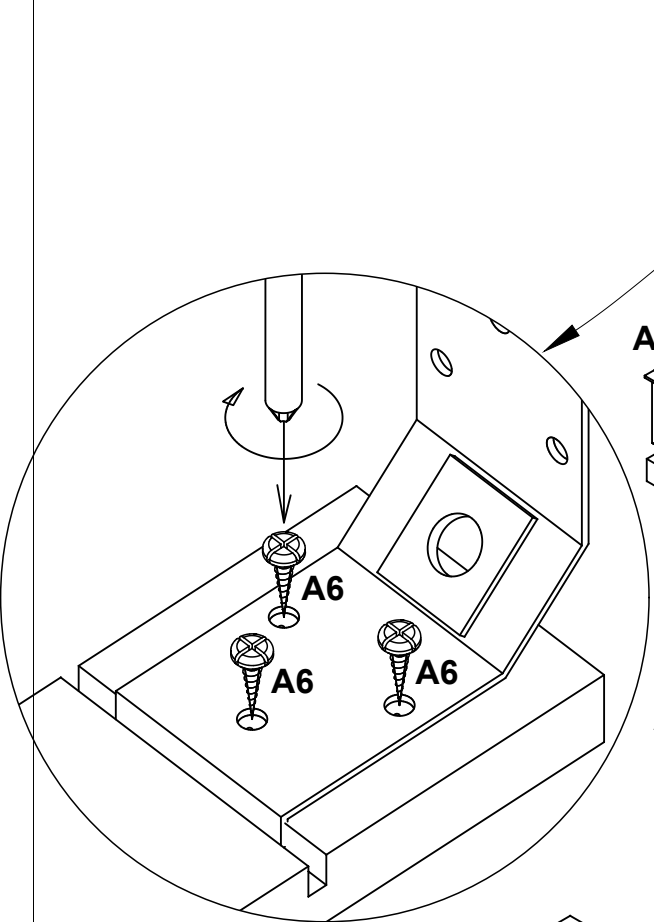
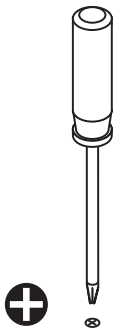

4

A8 |  x4  
M6 x 10x20 mm

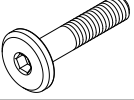
A9 |  x4  
M6 x 35 mm

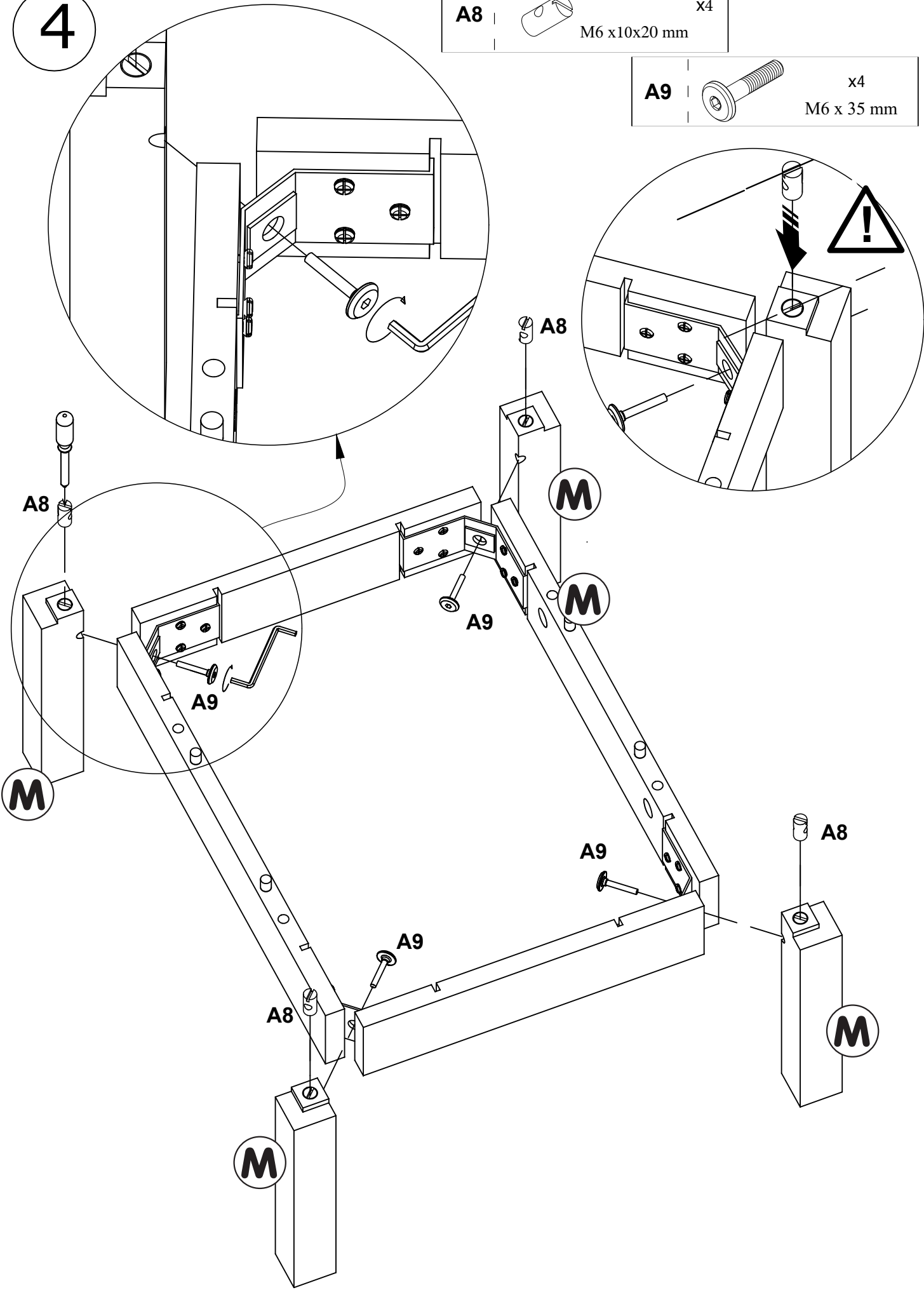

5

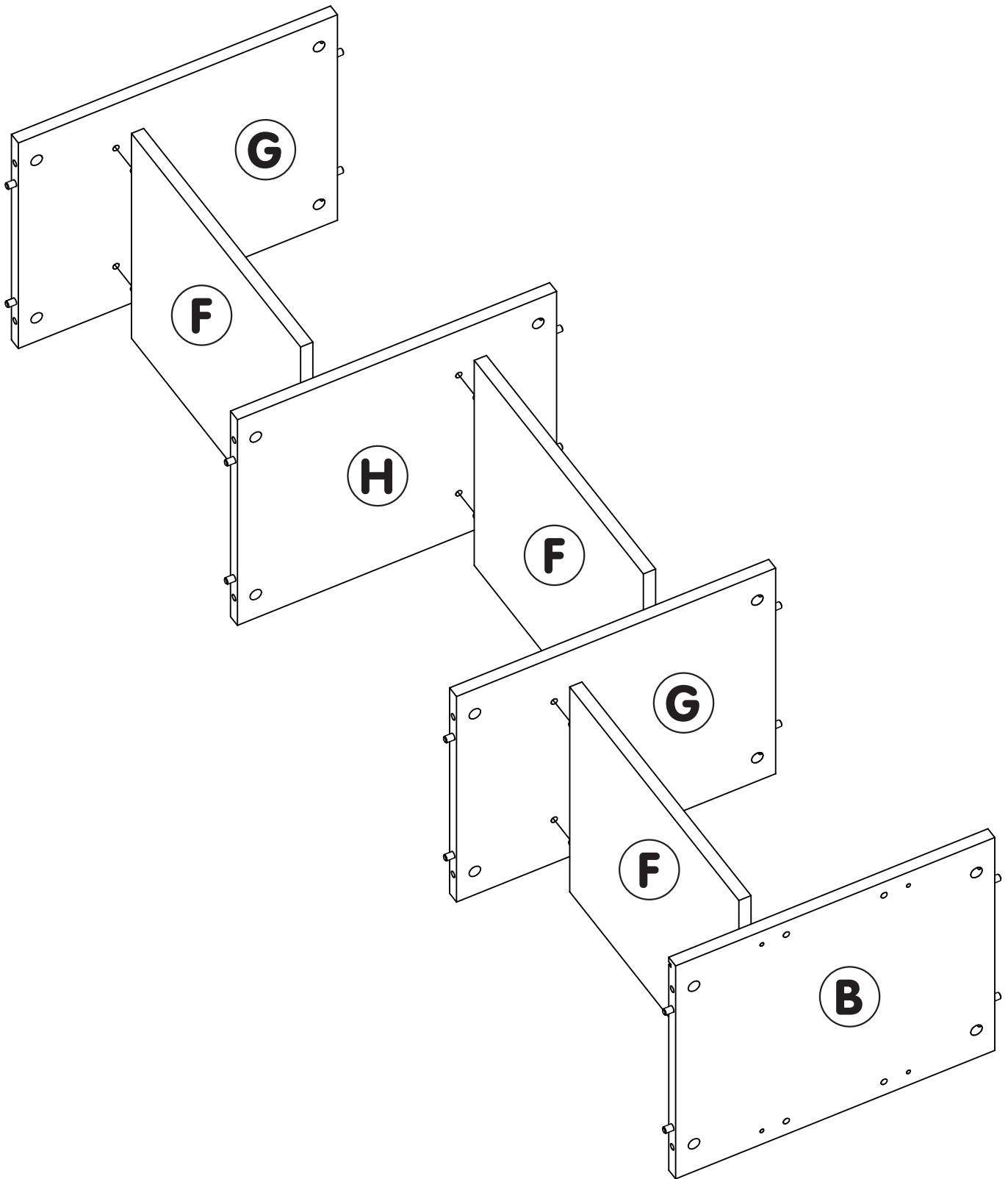



6

A2 |  x16

A4 |  x12  
BLACK

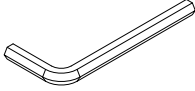
A13 | 

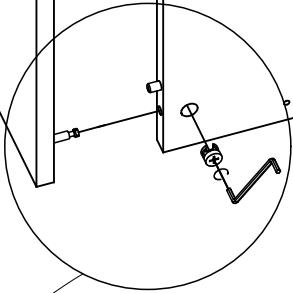
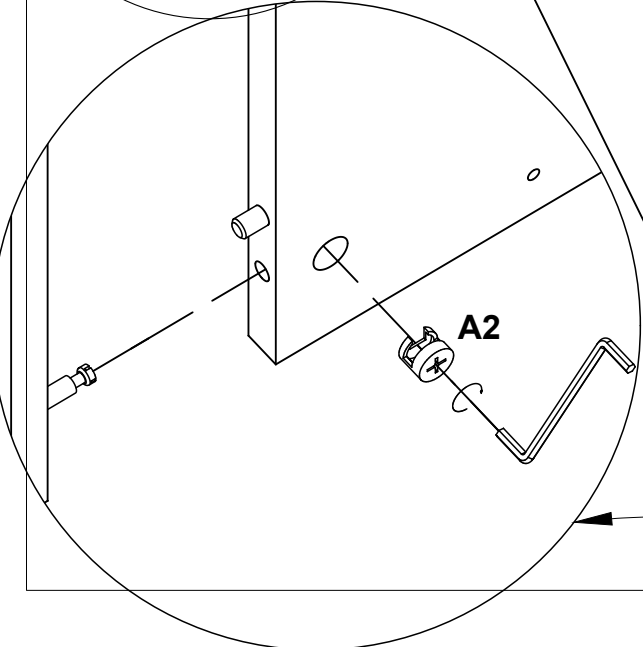
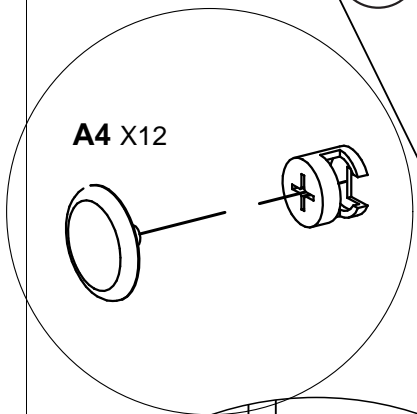
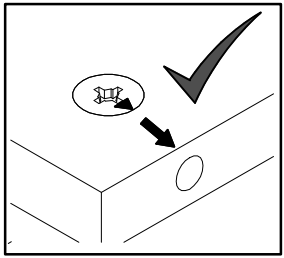
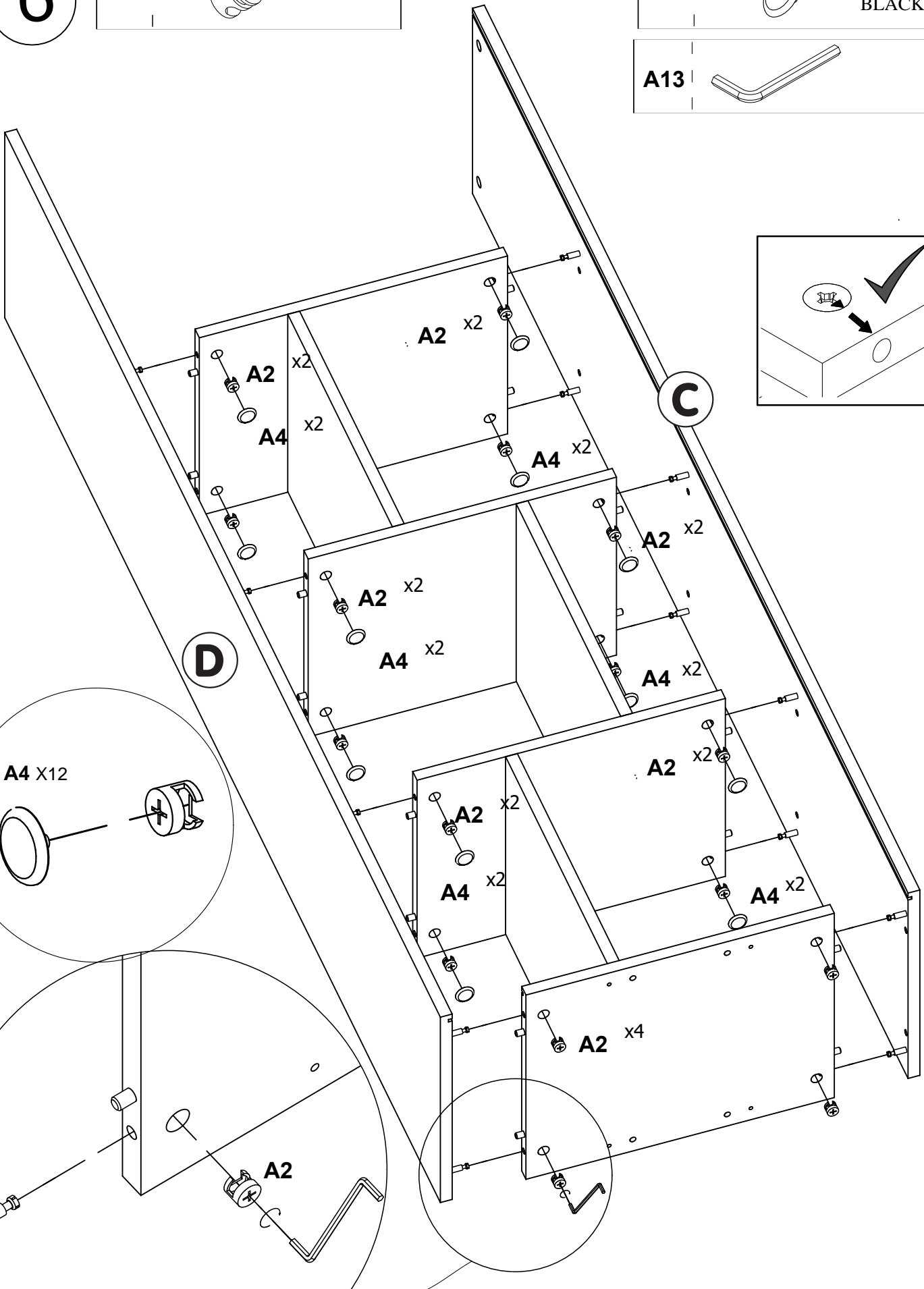

7

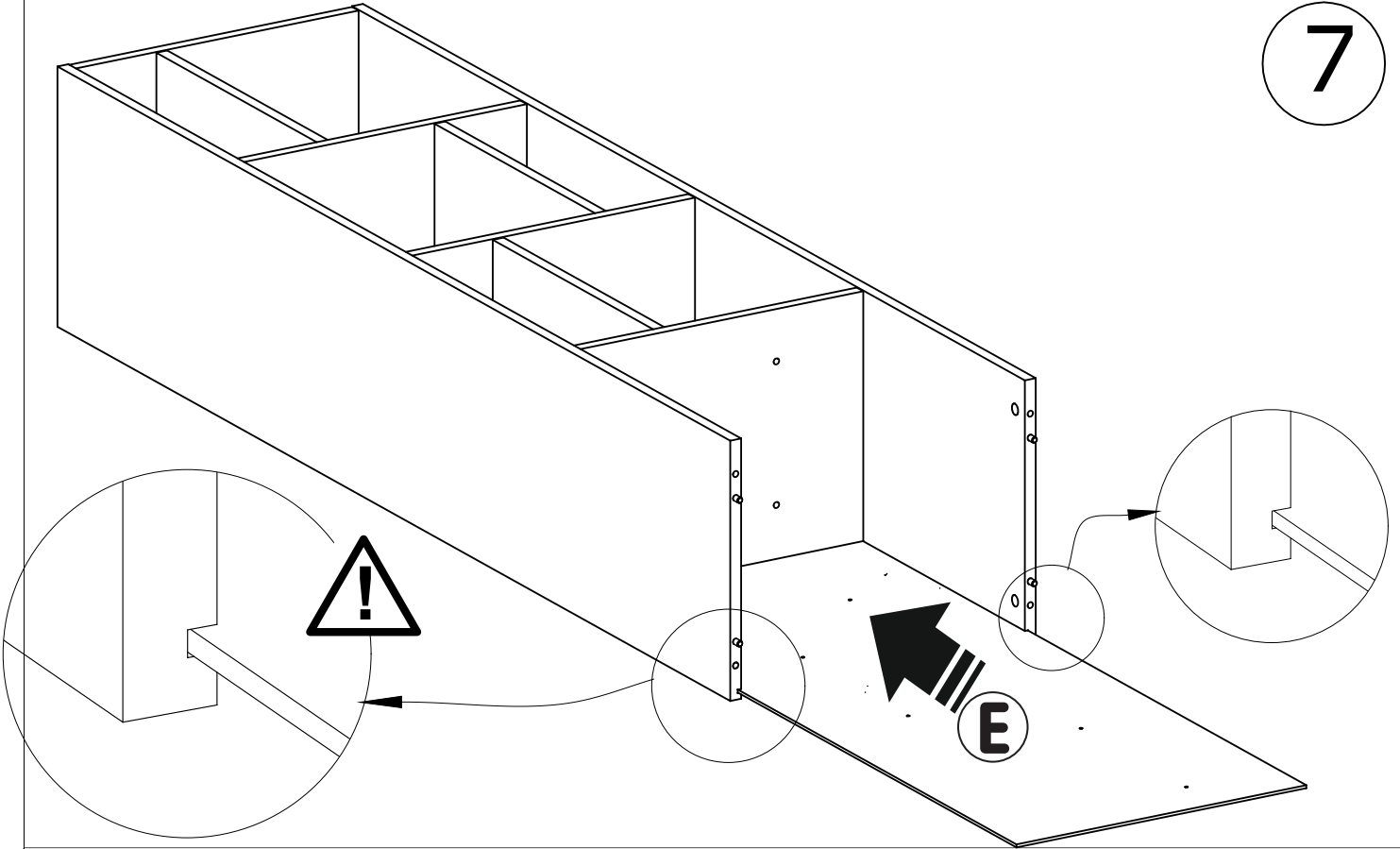

8

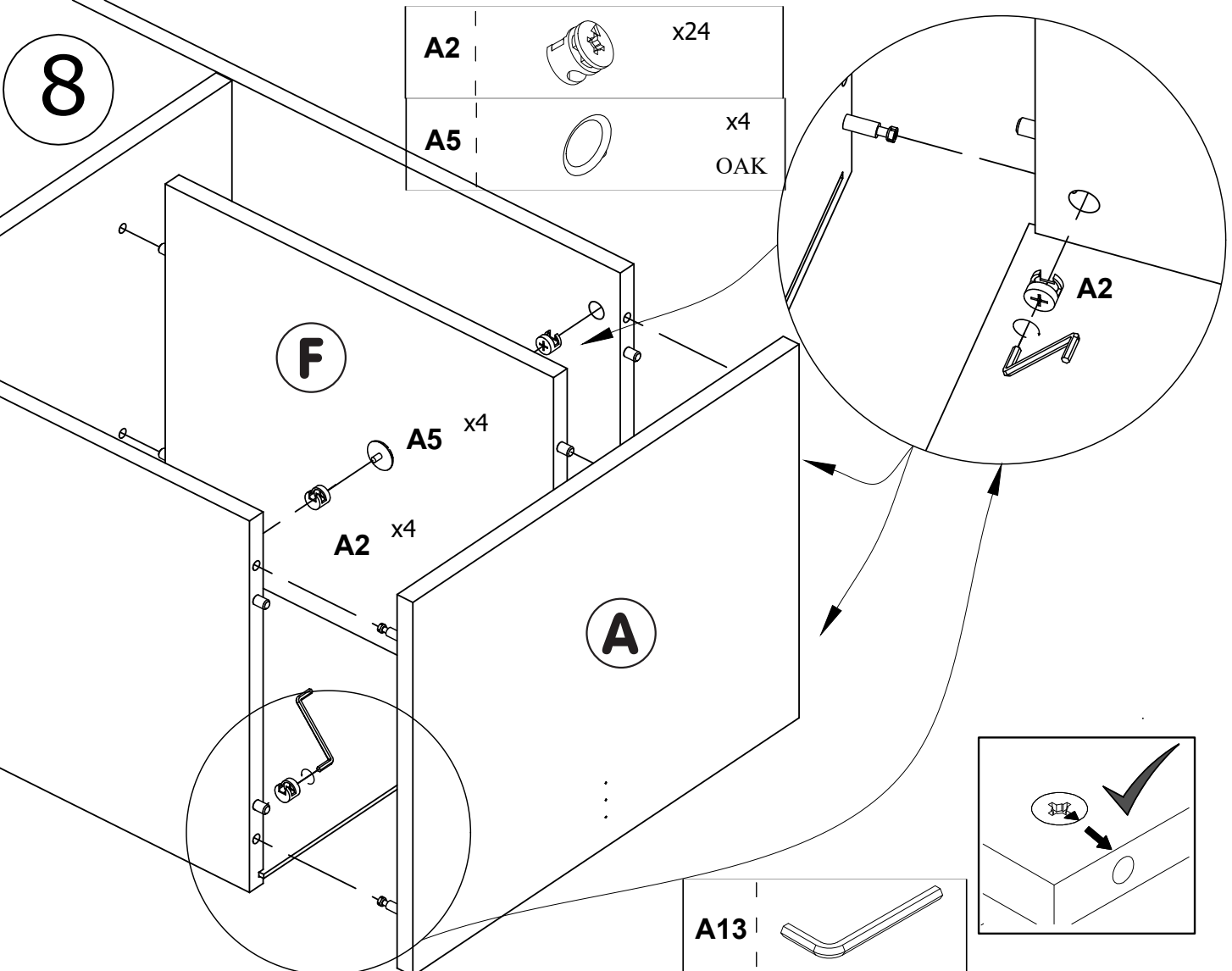

9

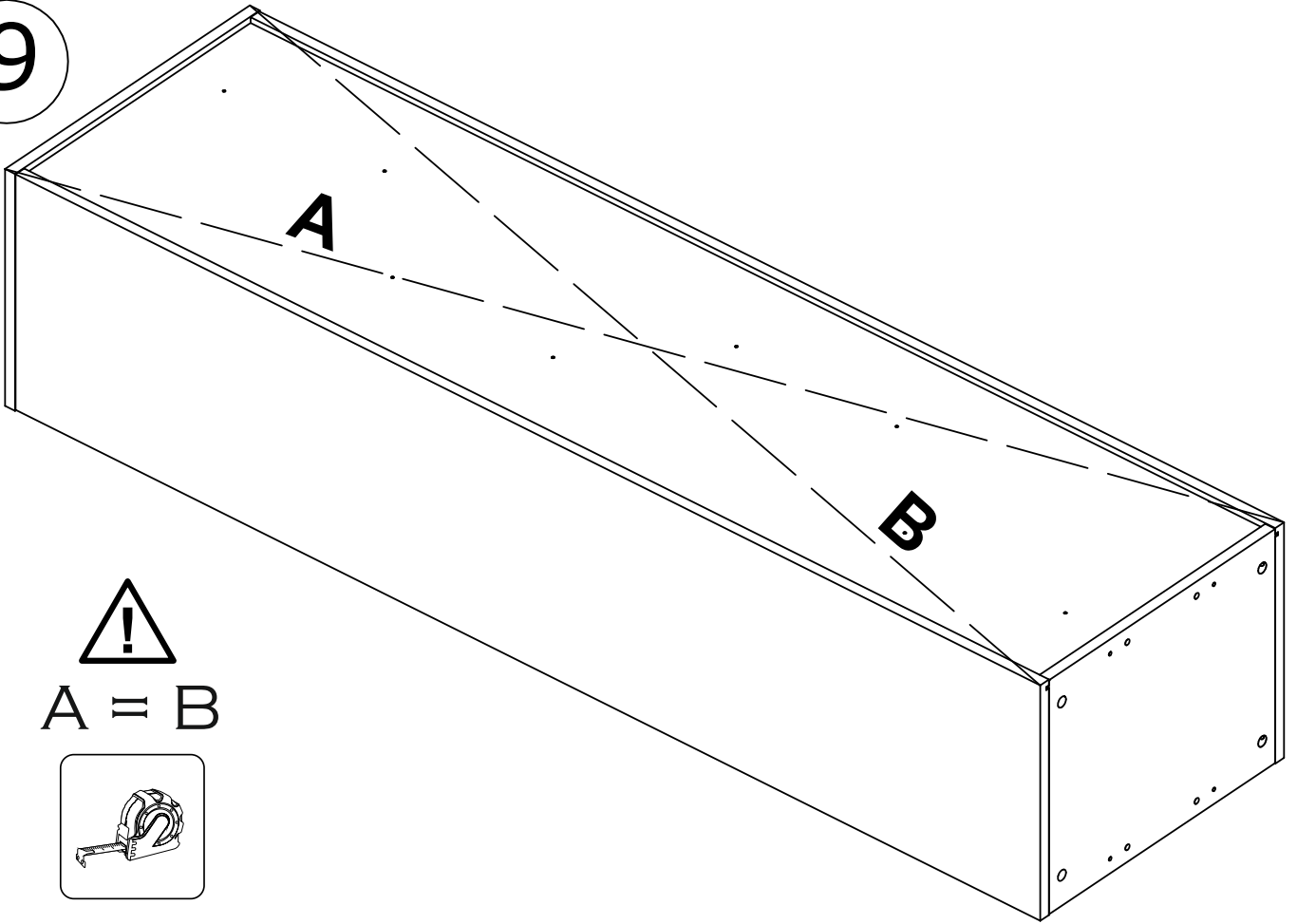

10

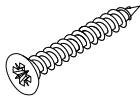
A14 |  x8  
3 x 20 mm

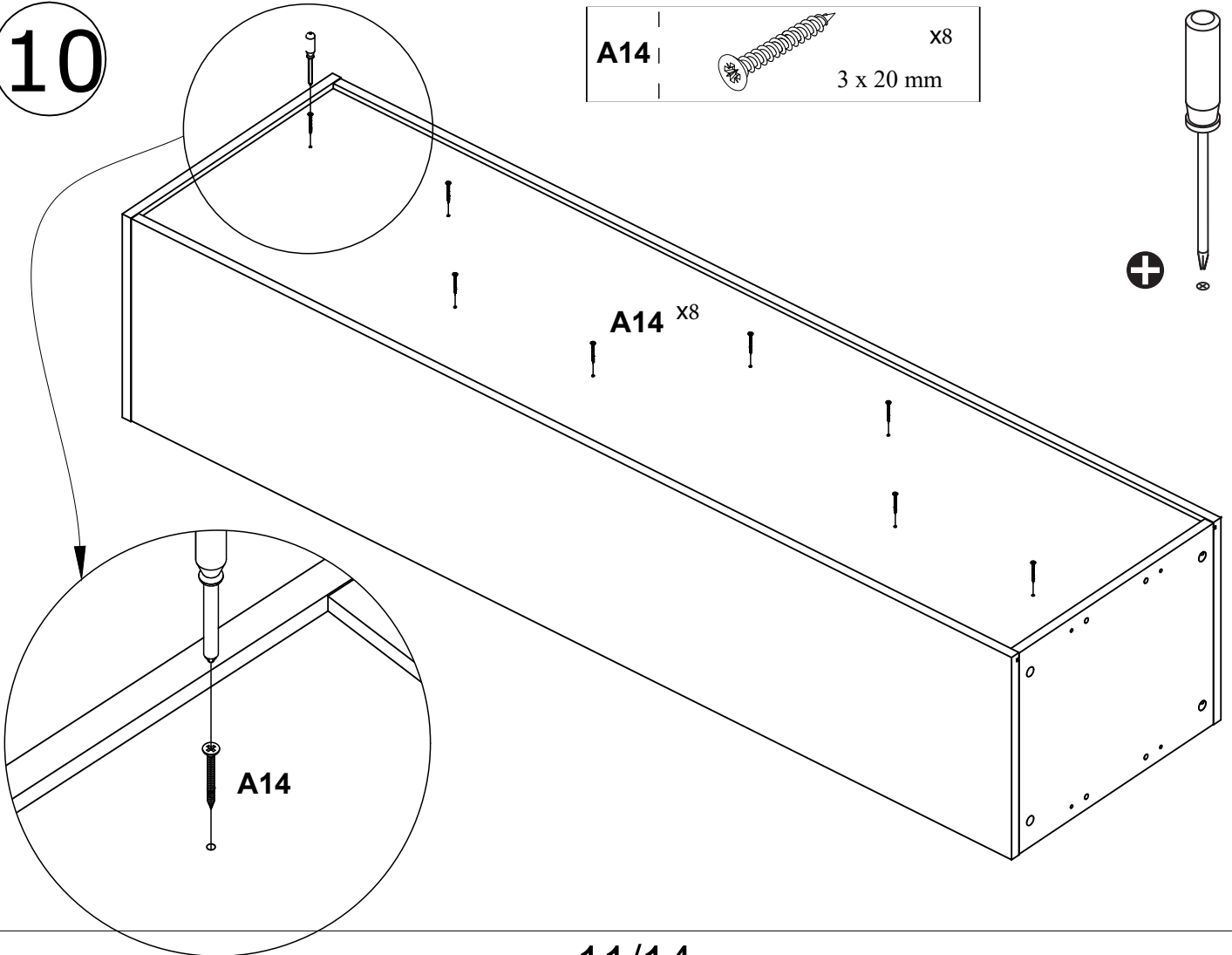
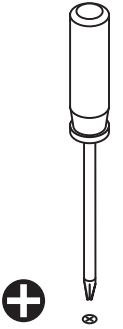

11

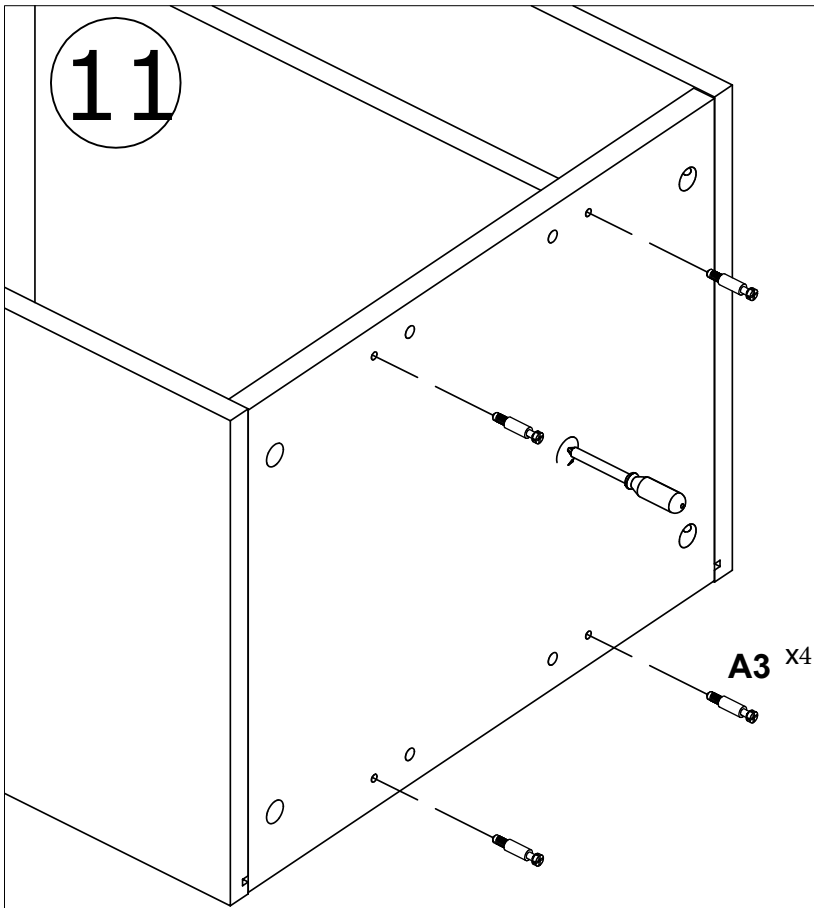

A3

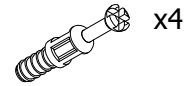

x4

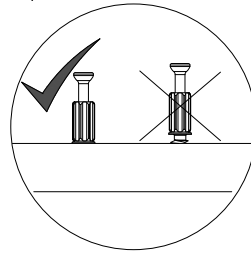

A3 x4

12

A2



x4

A12

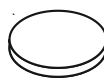

x4

28 mm

A13

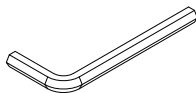

A12 x4

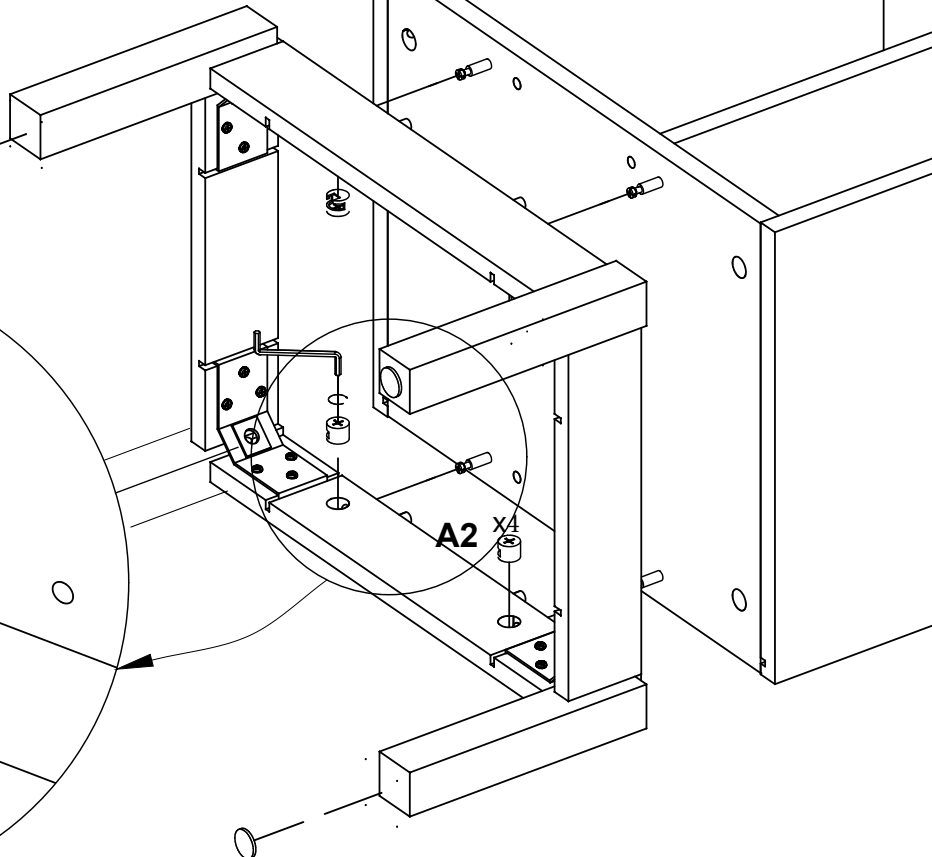

A2 x4

A2

13

A10

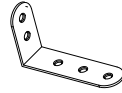

x1

1827  
mm

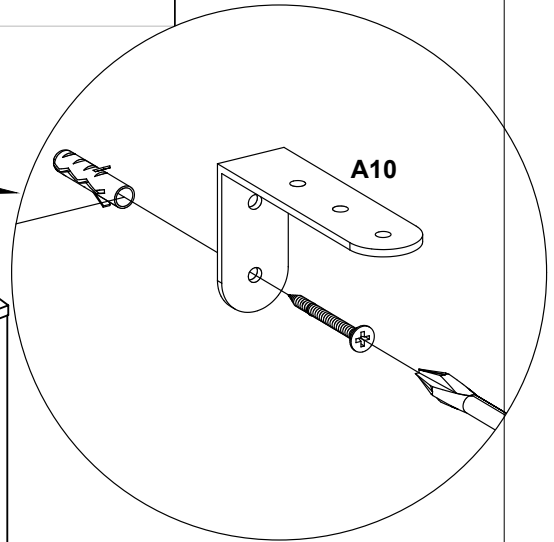
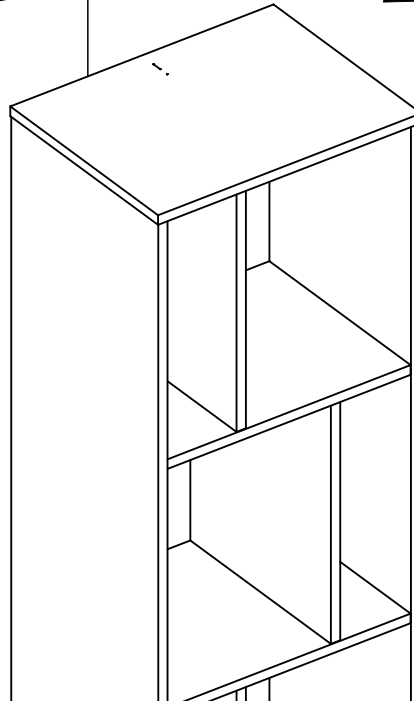
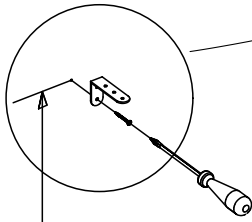

⚠ Achtung • Attention • Attenzione Opgelet • Uwaga • Pozor • Figyelem Atenție • Dikkat • Внимание ⚠	
(D)	Wandbefestigung dient als Kippschutz – unbedingt anbringen! Bei einigen Wandtypen kann ein Spezialdübel erforderlich sein!
(GB)	The wall fastening serves to prevent tipping – be absolutely sure to mount it! For certain wall types, a special wall plug may be necessary!
(FR)	La fixation murale sert de protection contre le basculement – à installer impérativement ! Pour certains types de murs il faut des chevilles spéciales !
(IT)	Il fissaggio alla parete serve da protezione anti-ribaltamento – attaccarla assolutamente! Per alcune strutture di parete può essere necessario un tassello speciale!
(NL)	Bevestiging aan de muur dient als kantelbescherming – zeker en vast bevestigen! Bij enkele muurtypes is een speciale plug misschien vereist!
(PL)	Mocowanie do ściany jest jednocześnie zabezpieczeniem przed przewróceniem – koniecznie zamontować! Do niektórych rodzajów ścian koniecznie zastosować specjalne kołki mocujące.
(CZ)	Montáž na stěnu slouží jako ochrana proti převrnutí – bezpodmienečně umístěte! U některých typů stěn může být zapotřebí speciální hmoždinka!
(SK)	Upevnenie na stenu slúži ako ochrana proti prevráteniu – bezpodmienečne použite! Pre niektoré druhy stien môže byť potrebná špeciálna hmoždinka!
(HU)	A terméket a falhoz kel rögzíténi, különben az felborulhat! Egyes faltípusoknál speciális tiplit kell használni!
(RO)	Sistemul de fixare la perete servește ca protecție la răsturnare – de montat obligatoriu! Pentru unele tipuri de pereți este posibil să fie necesar un diblu special!
(TR)	Duvardaki sabitleme, devrilmeye karşı bir emniyet tedbiridir ve mutlaka monte edilmelidir! Bazı duvar tiplerinde bunun için özel bir dübel gerekli olabilir!
(RU)	Обязательно установите крепление на стене во избежание опрокидывания! Для некоторых типов стен может потребоваться специальный дюбель!

14

A11



x2

3,5 x 15 mm

