

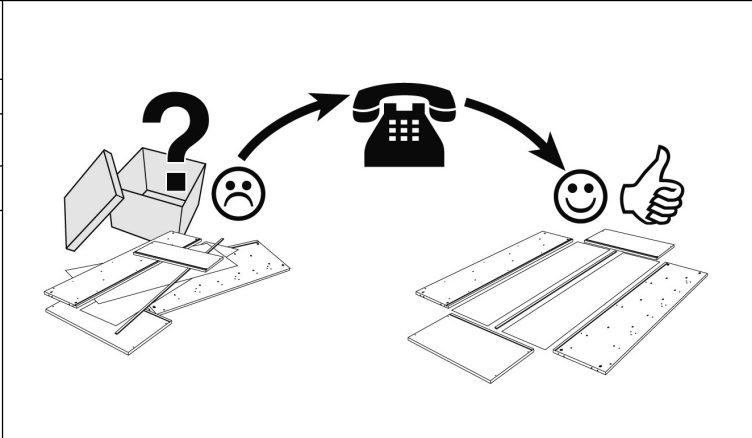

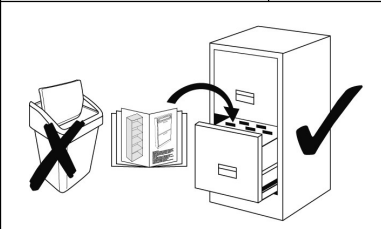









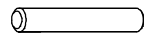

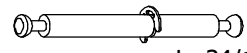





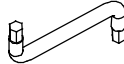
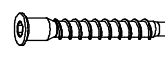

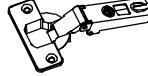
Service • Assistenza • Dienstverlening • Serwis
 Servis • Szerviz • Сервисная служба

Name • Nom • Nome • Naam
 Nazwa • Jméno • Názov • Név
 Denumire • Isim • Название

Nr • No • N • Номер • Č • Sz

Тур • Туре • Тір • Тірус • Тіро
 Тип

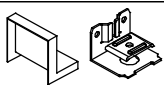

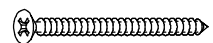
		H1		x22 ø 8x30	H3		x3 Ø8x50	
D5		x26 ø 15x12,5	D117		x2 L=34/16/34	D2		x22 ø 5/11x34
D4		x20 ø 17	D63		x16	D1		x12 ø 5
D24		x4 Ø13	A5		x1 SW4	A27		x4 ø 7x50
G101		x5 2mm	G98		x5 ø35	A1		x10 ø 3,5x15
B122		x2	A278		x2 M4x15	A16		x4 M4x25
N3		x2 Ø7x1,5	D36		x12 15x15x10	A10		x2 ø 4x16
D31		x1	H8		x1 ø 6x35	A69		x1 ø 4x60



idp68246-1 idp68246-2

Teil Nr. Pièces Nr. Pieces Nr. Часть Ном. Kawalek Nr. Parça No Kusů Nr. Kusov Nr. Pezzi Nr. Nr piese. Darab száma. Stukken Nr. Kārtas Nr.	Anzahl Quantité Quantity Количество Ilość Miktar Množství Množstvo Quantità Cantitatea Mennyiség Hoeveelheid Skaitis	Kasten Nr. Colli Nr. Colli Nr. Коробка Ном. Polu Nr. Kutusu Nr. Kolonka Č. Počet balení Colli Nr. Nu pachete Colli száma. Colli Nr. Kastes Nr.	Maß, mm Dimensions, mm Dimensions, mm Размеры, mm Wymiary, mm Boyutlar, mm Rozměry, mm Rozmery, mm Dimensioni, mm Dimensiuni, mm Méretek, mm Afmetingen, mm Izmēri, mm	
001	4	1 / 2	120 x 60 x 30	
032	1	1 / 2	245 x 458 x 15	
039	1	2 / 2	1880 x 476 x 15	
042	1	1 / 2	458 x 458 x 15	
044	3	1 / 2	458 x 450 x 15	
045	1	2 / 2	1864 x 476 x 15	
046	1	2 / 2	1880 x 476 x 15	
047	1	1 / 2	718 x 476 x 15	
048	1	1 / 2	750 x 500 x 15	
049	4	1 / 2	245 x 450 x 15	
066	1	2 / 2	1873 x 467 x 3	
067 (068)	1	2 / 2	1873 x 254 x 3	
80	1	2 / 2	1176 x 486 x 18	
81	1	2 / 2	696 x 486 x 18	

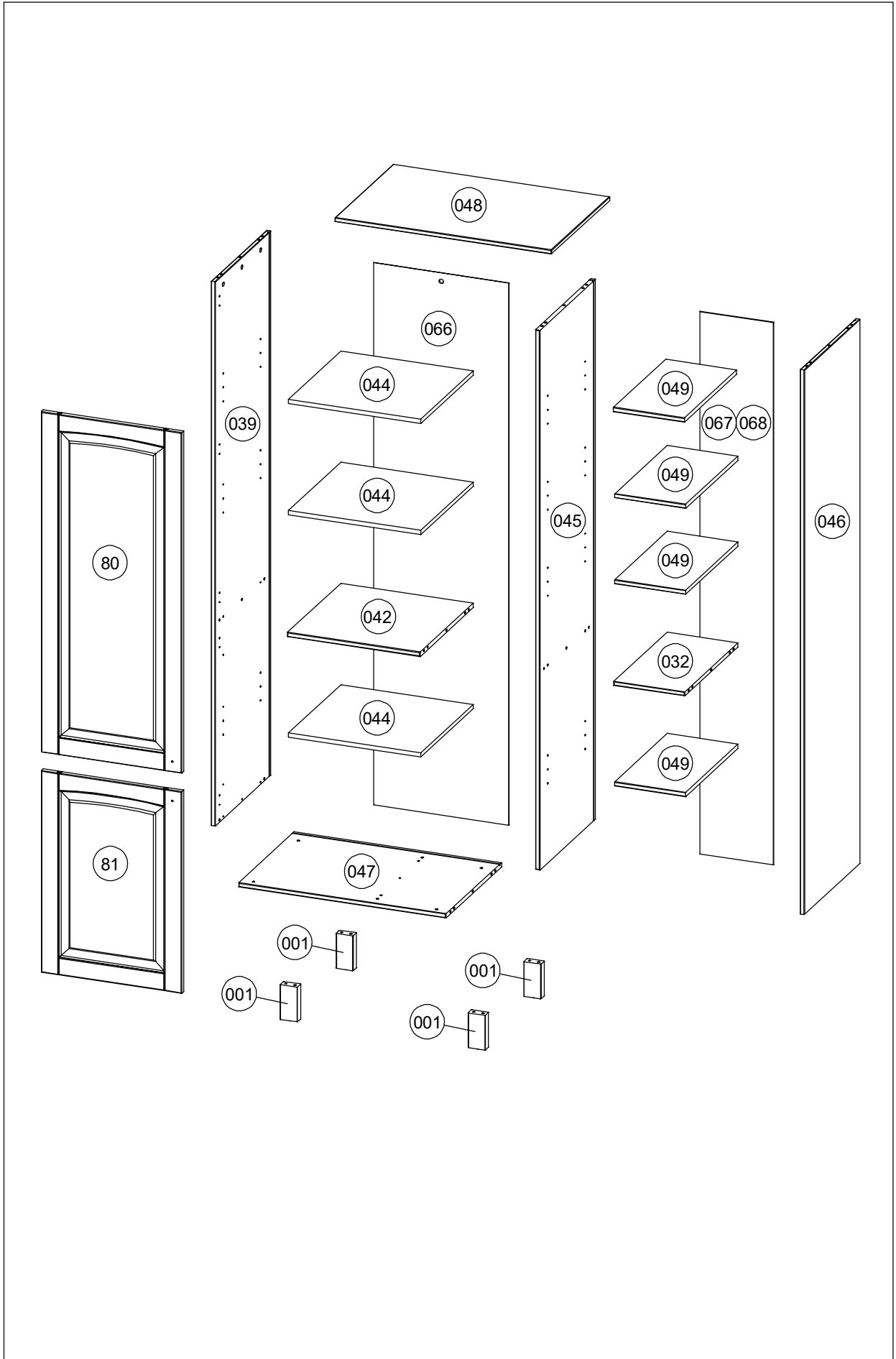
idp68246-1 idp68246-2



idp68246-1 idp68246-2

H1		x12 ø 8x30	D5		x18 ø 15x12,5	D2		x19 ø 5/11x34
----	---	---------------	----	---	------------------	----	---	------------------

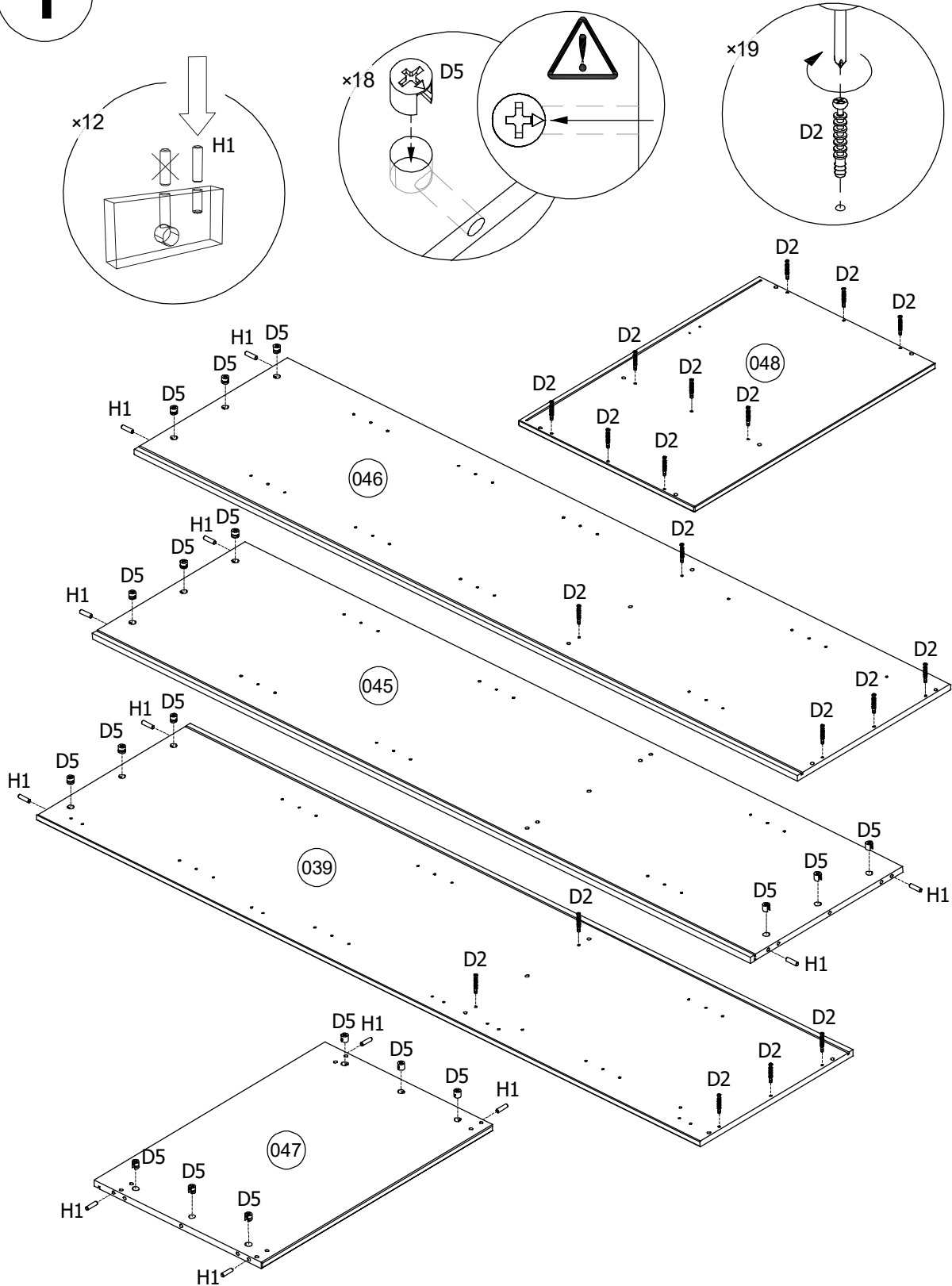

1

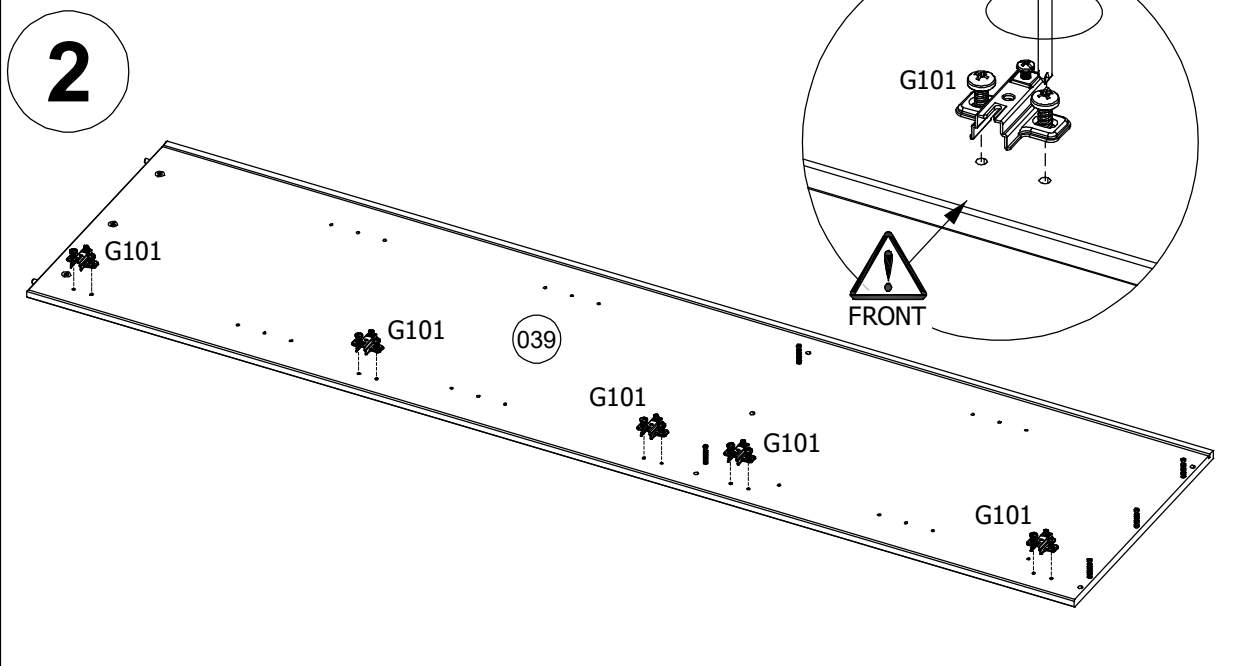

idp68246-1 idp68246-2

G101 |  x5
2mm

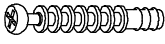

D31 |  x1 | A10 |  x2 | D2 |  x3
ø4x16 | ø 5/11x34

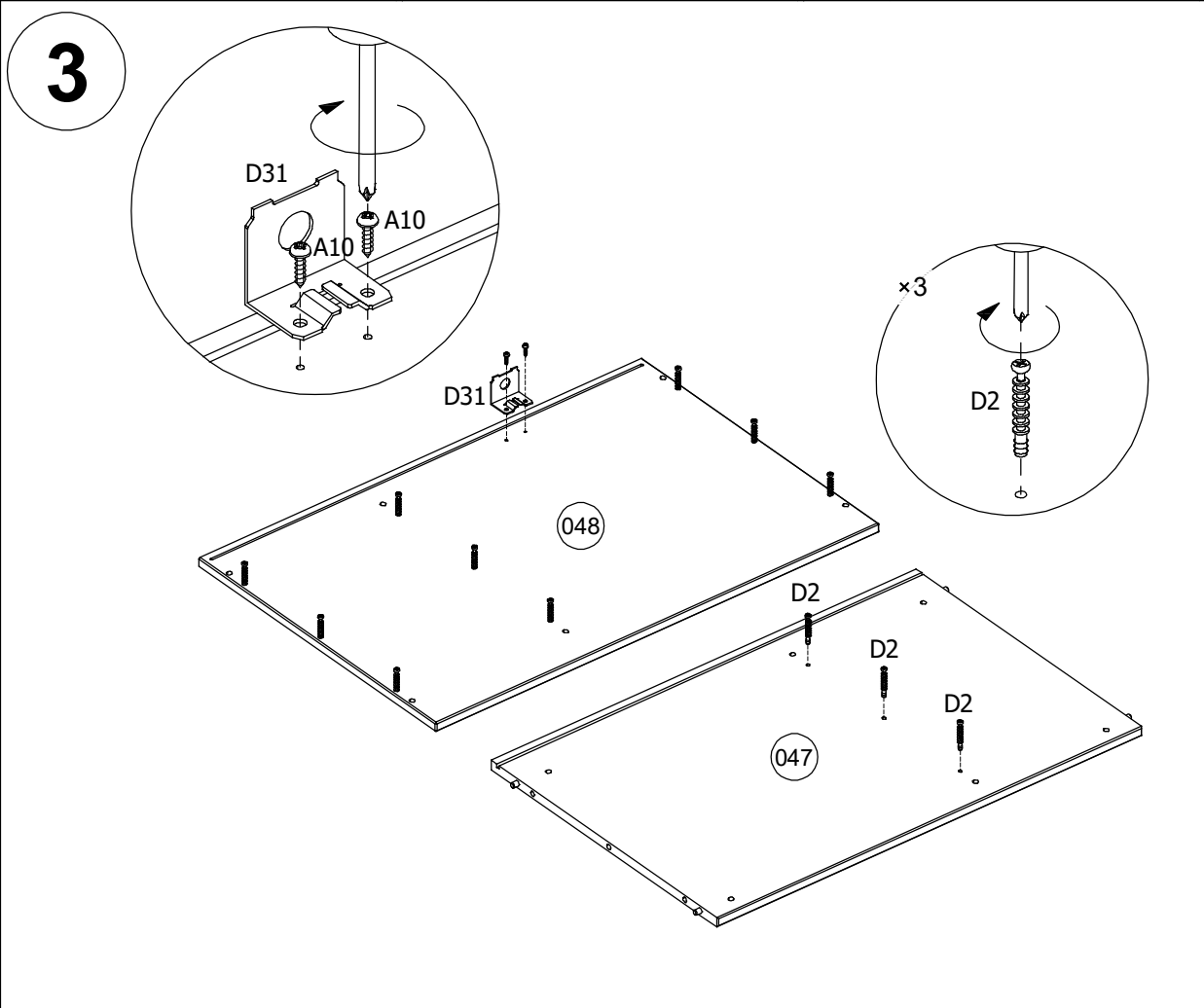

idp68246-1 idp68246-2

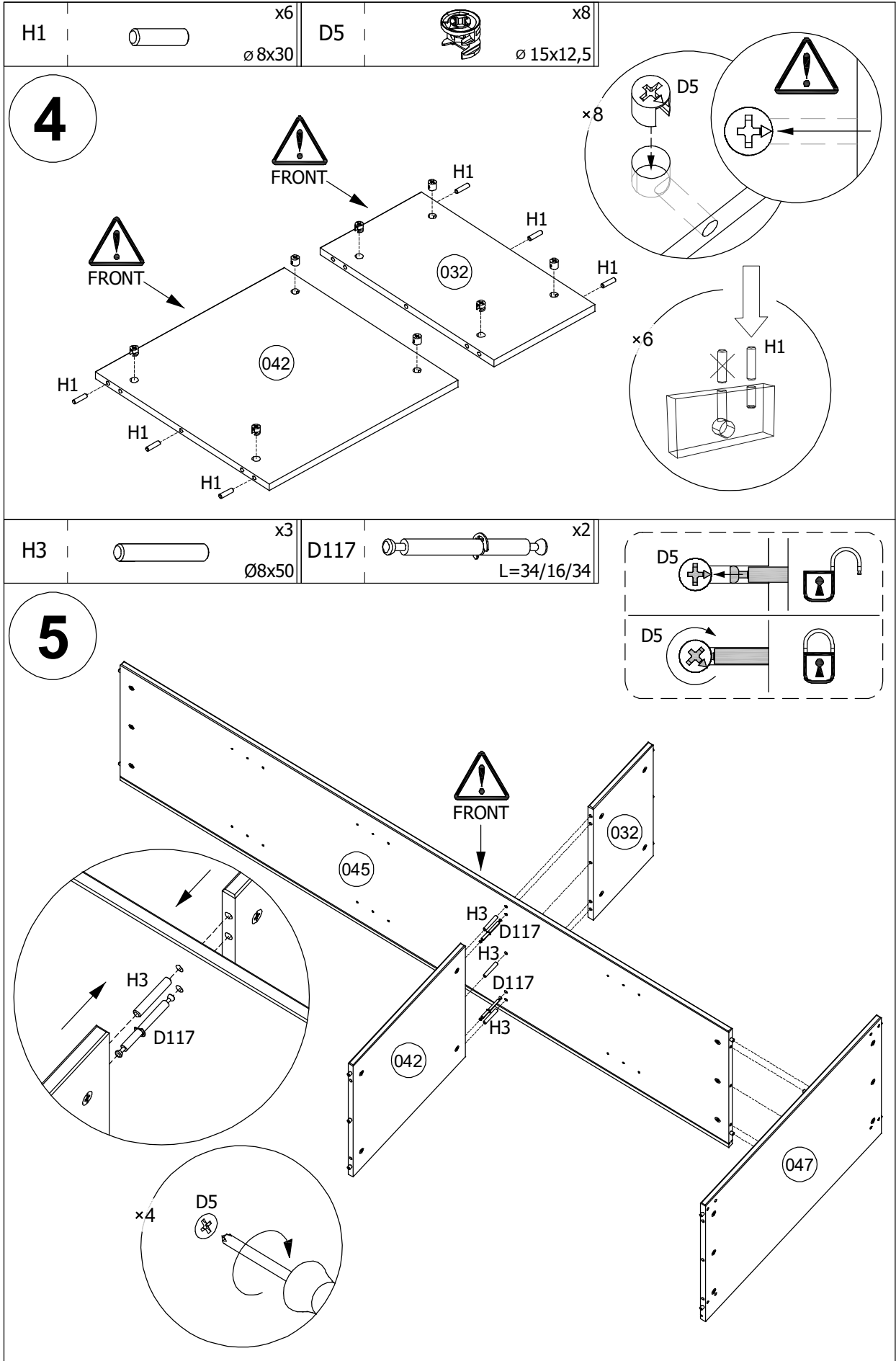

idp68246-1 idp68246-2

6

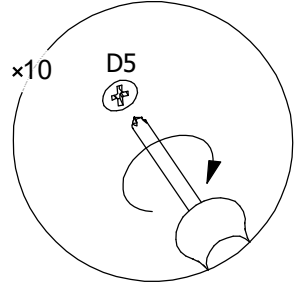
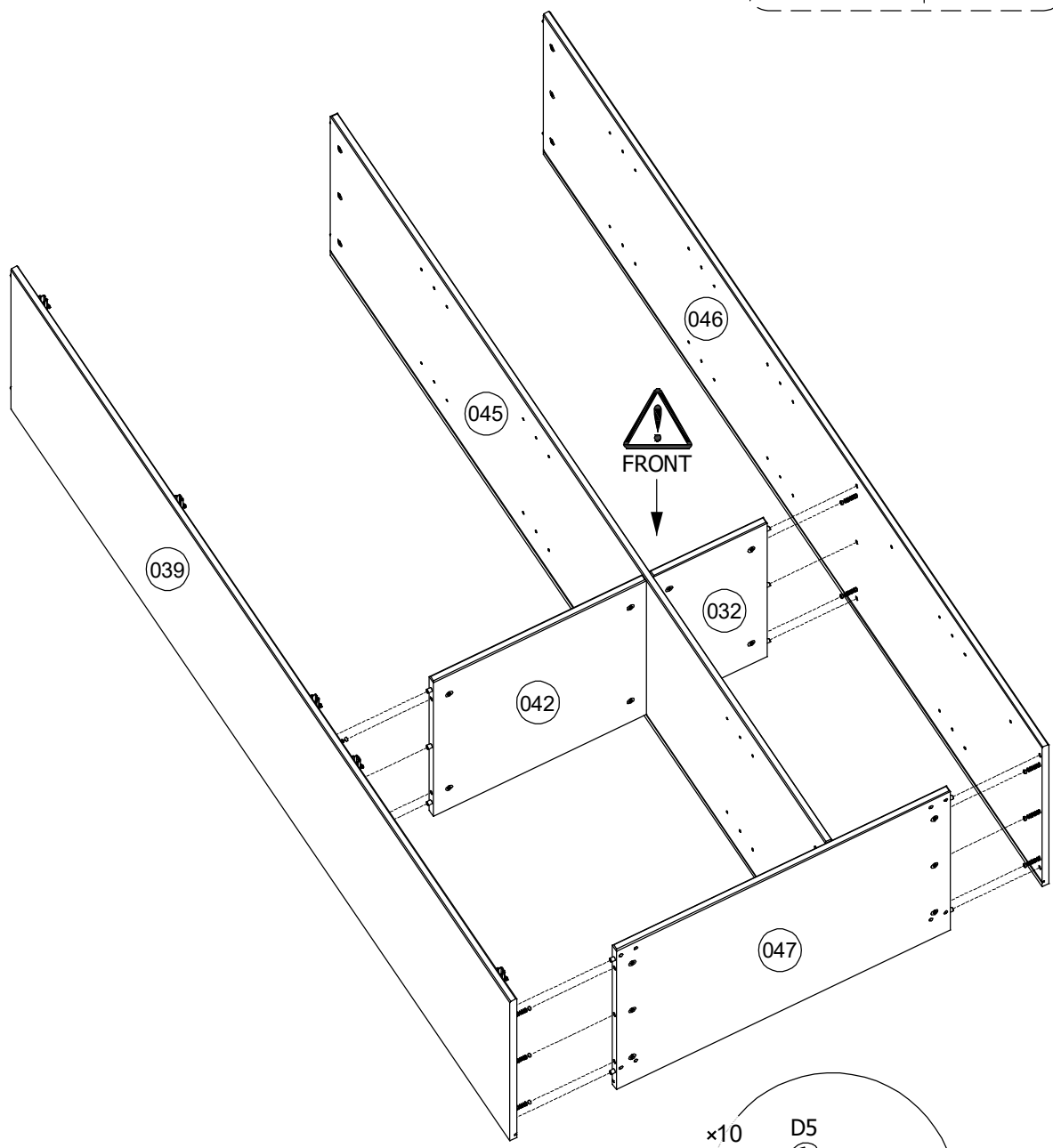
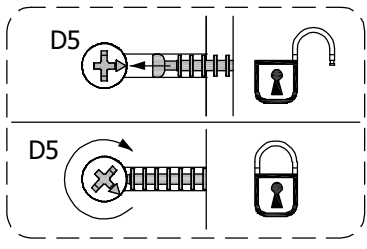

idp68246-1 idp68246-2

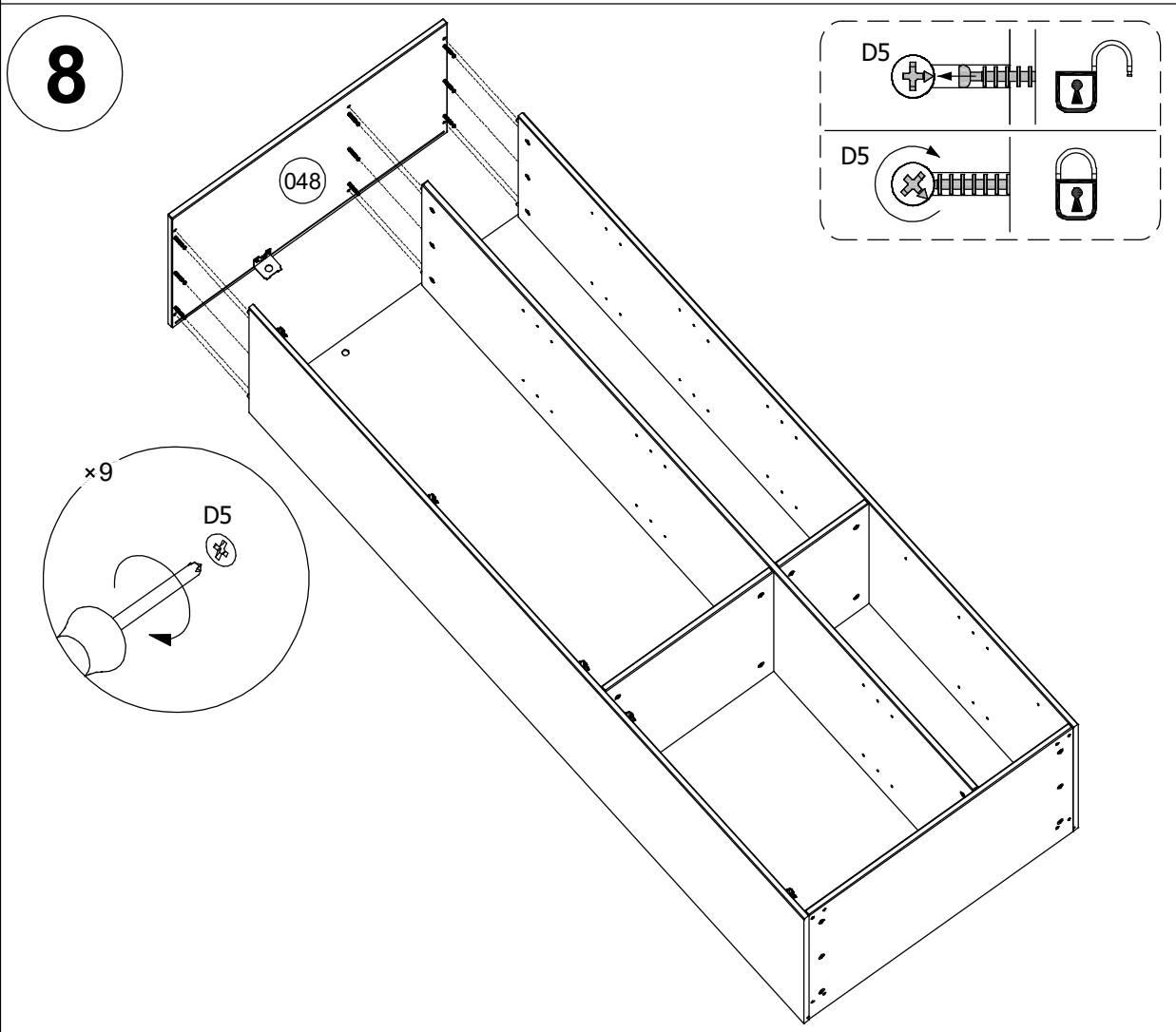
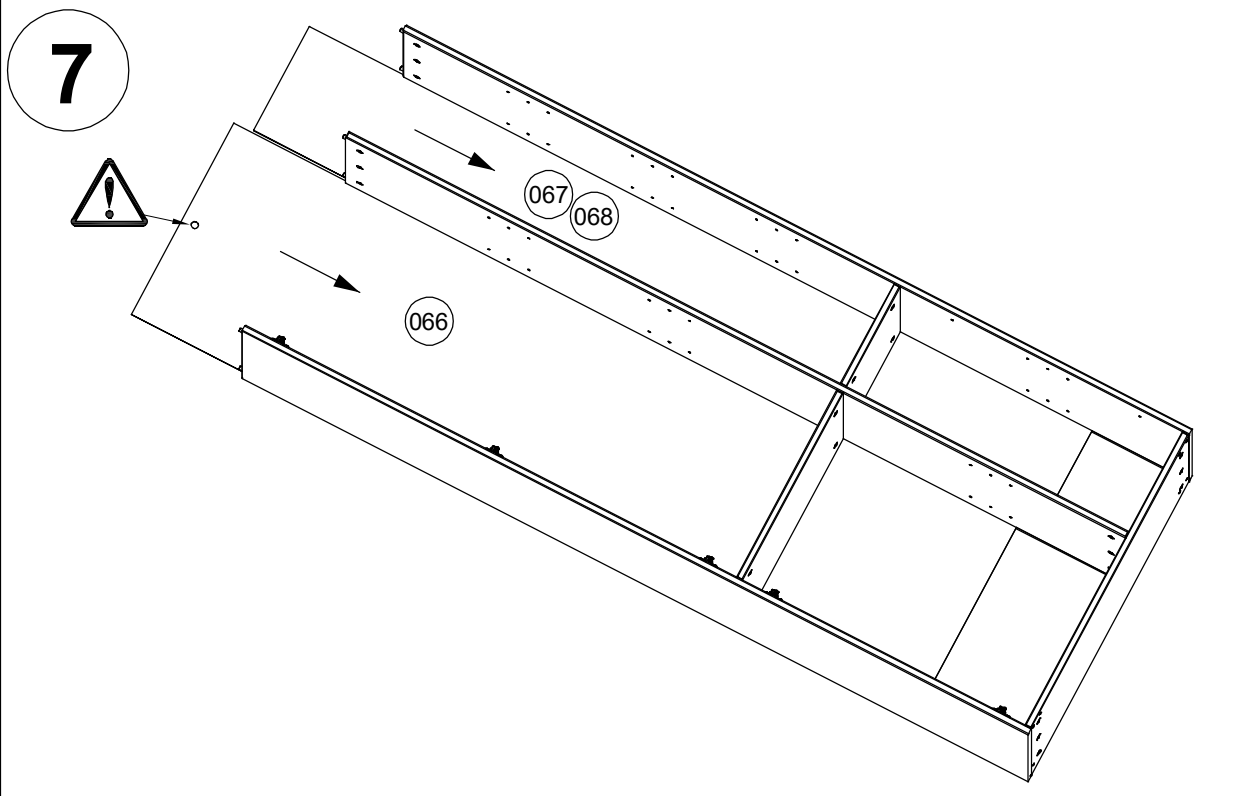

idp68246-1 idp68246-2

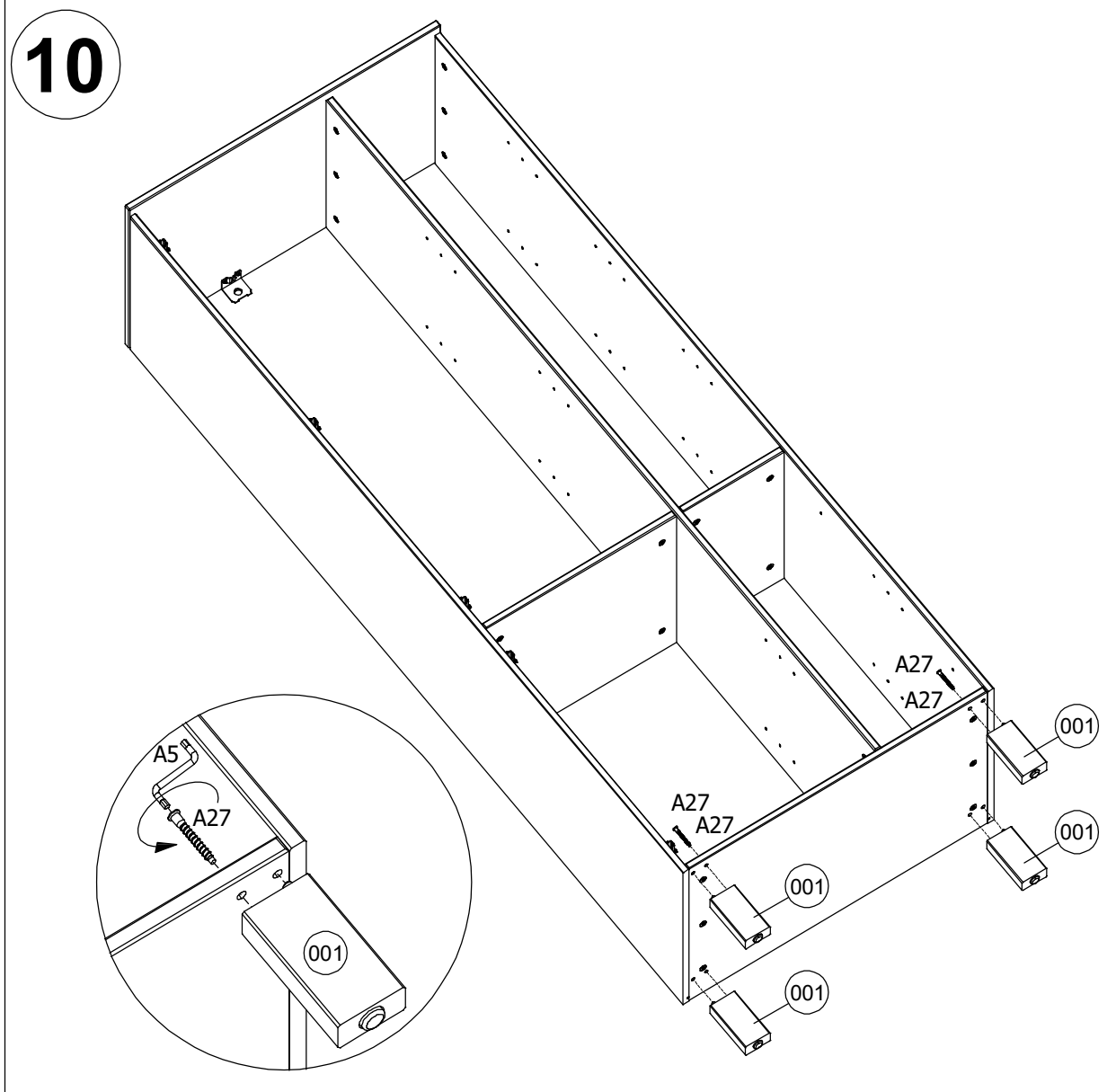
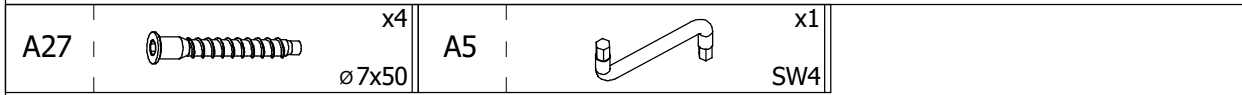
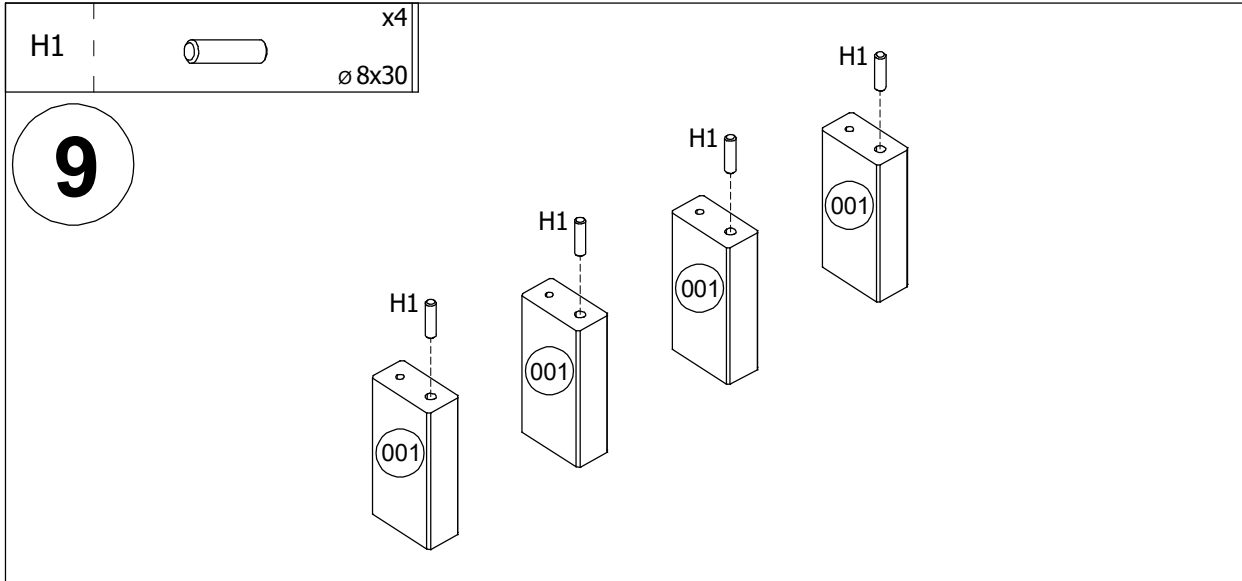

idp68246-1 idp68246-2

11

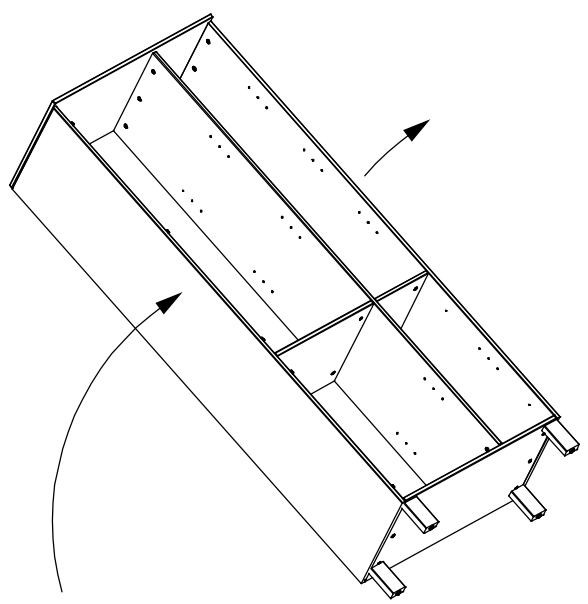
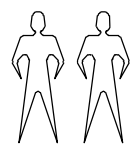

D36



x12

15x15x10

12

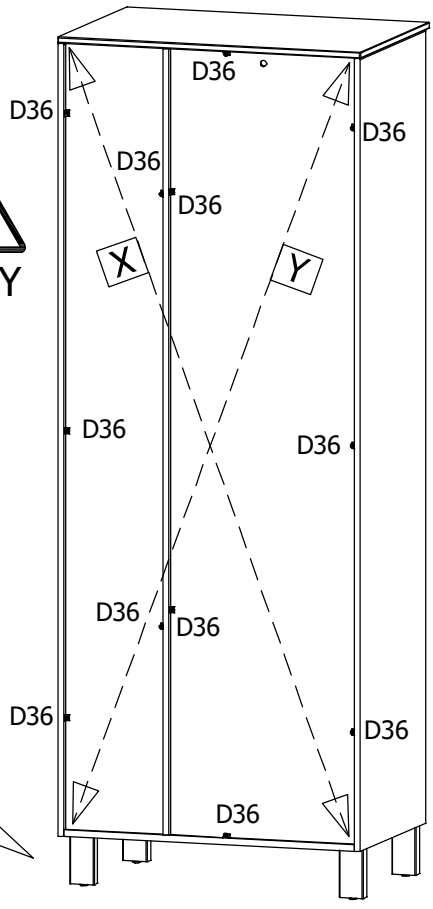
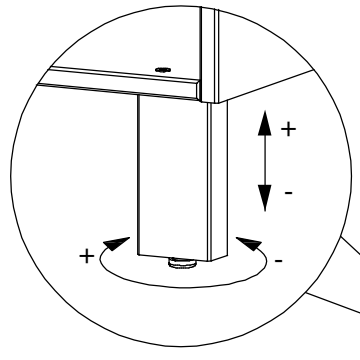
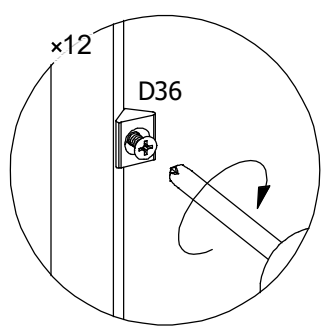
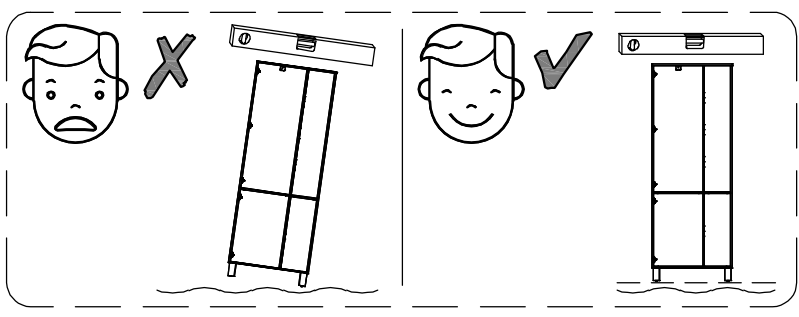
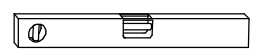
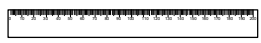

idp68246-1 idp68246-2

13

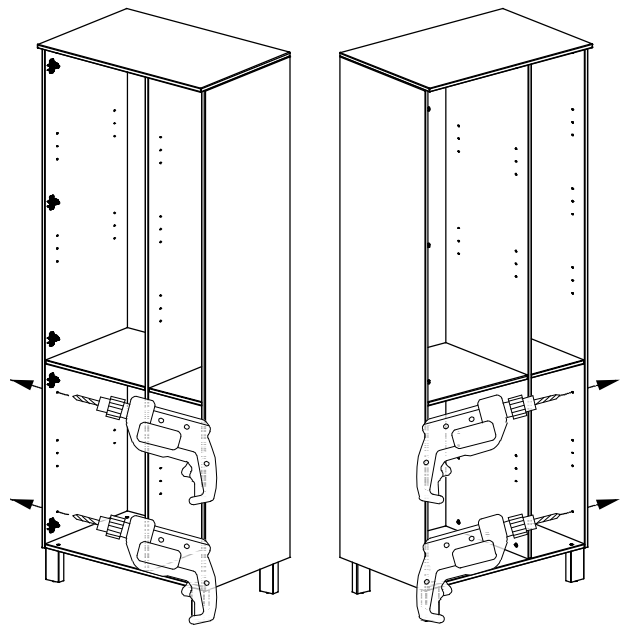
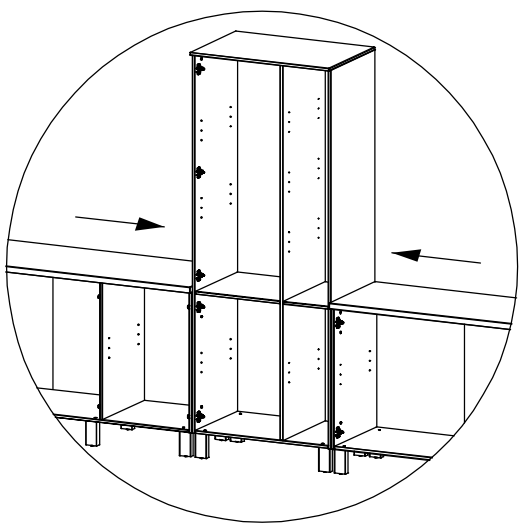
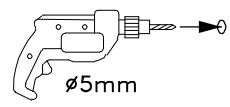

A278



x2

M4x15

A16





x2

M4x25

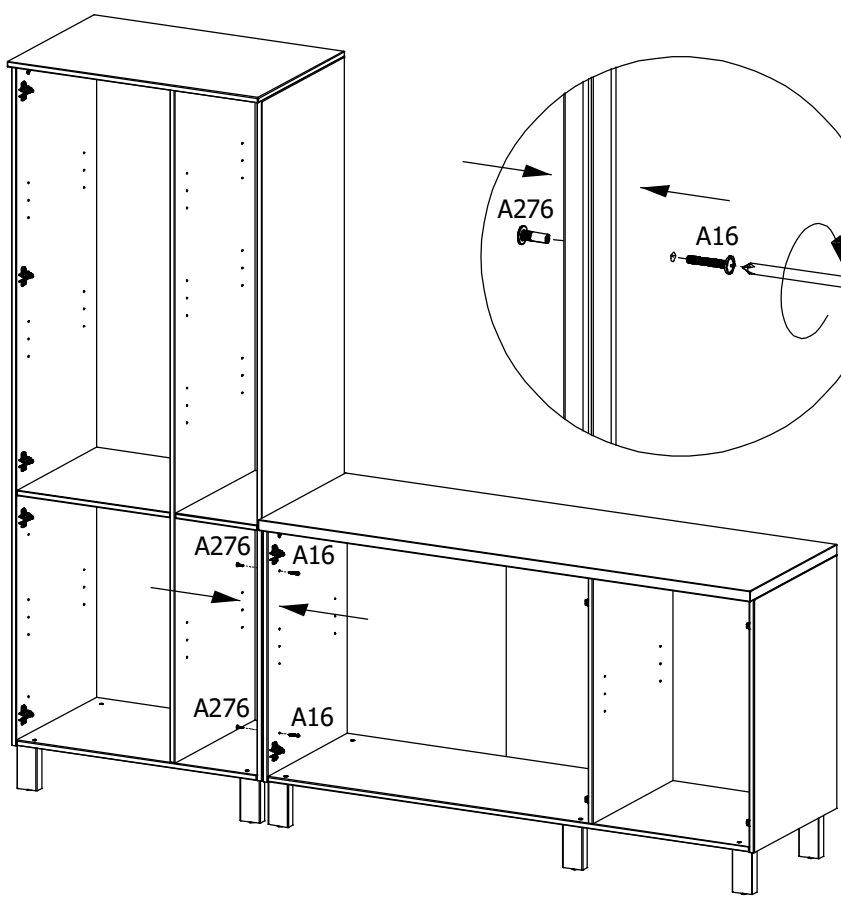
14



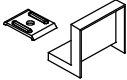

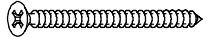

idp68246-1 idp68246-2

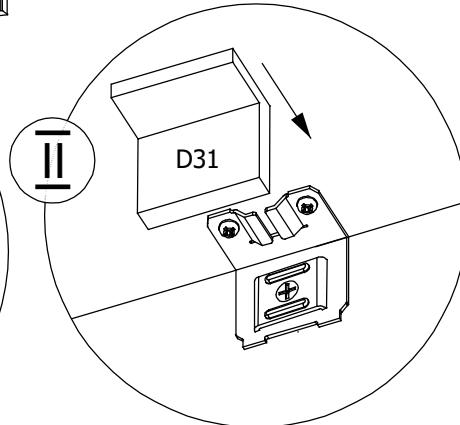
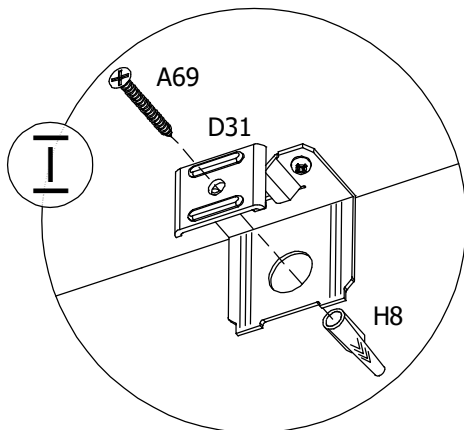
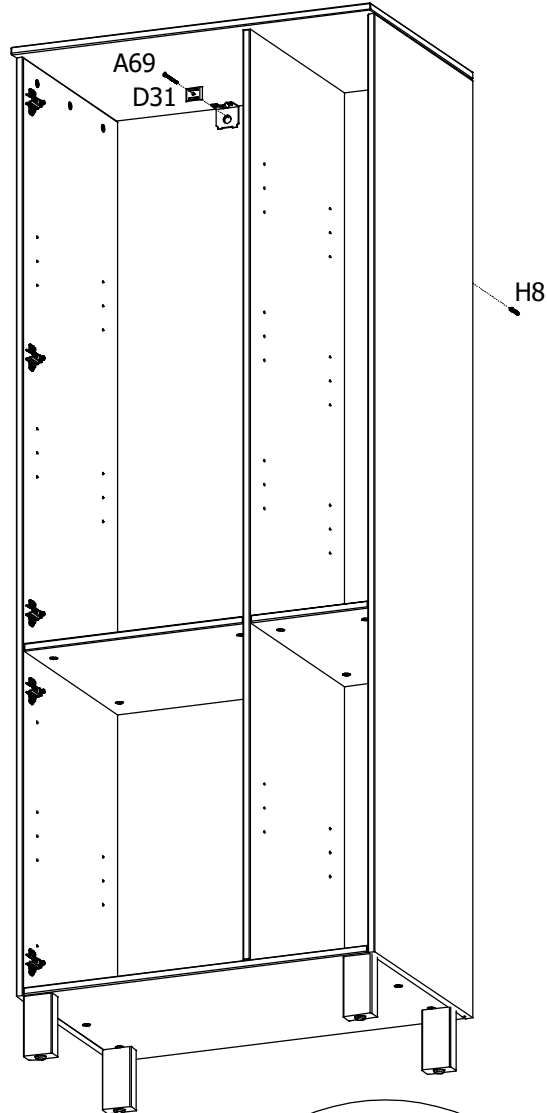
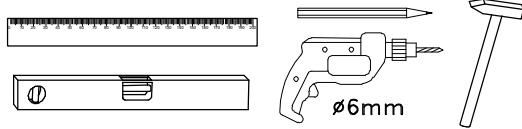
D31	 x1	H8	 x1	A69	 x1
			∅ 6x35		∅ 4x60

15



D1		x12 ø 5	D4		x20 ø 17	D24		x4 Ø13
D63		x16						

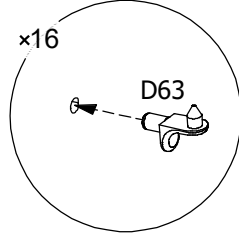
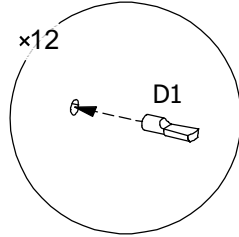
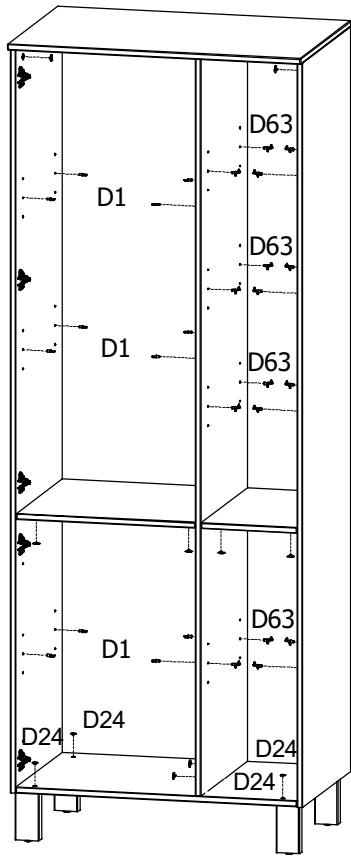
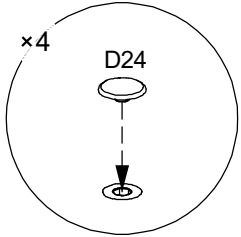
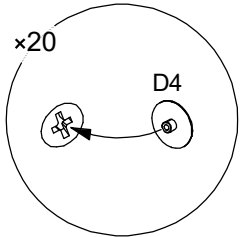

16

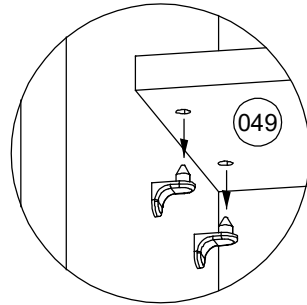
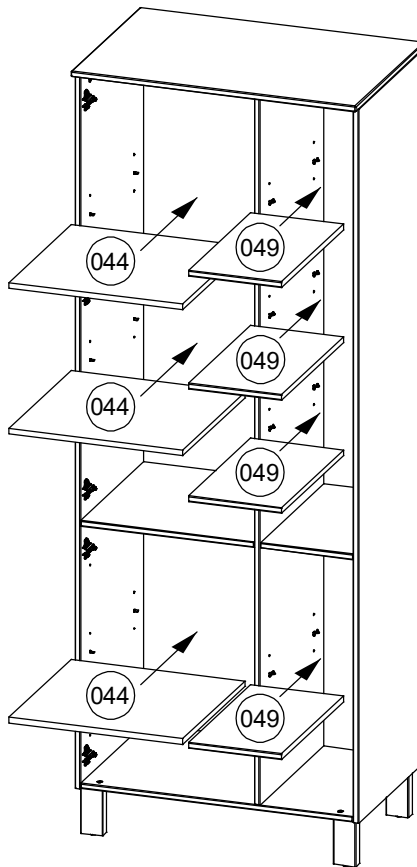
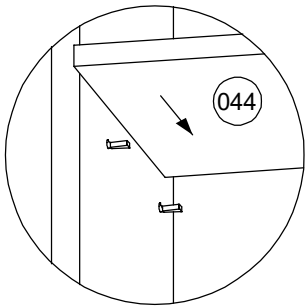

17

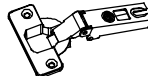

idp68246-1 idp68246-2

B122		x2	G98		x5 ø35	A1		x10 ø 3,5x15
------	---	----	-----	---	-----------	----	---	-----------------

A16		x2 M4x25
-----	---	-------------

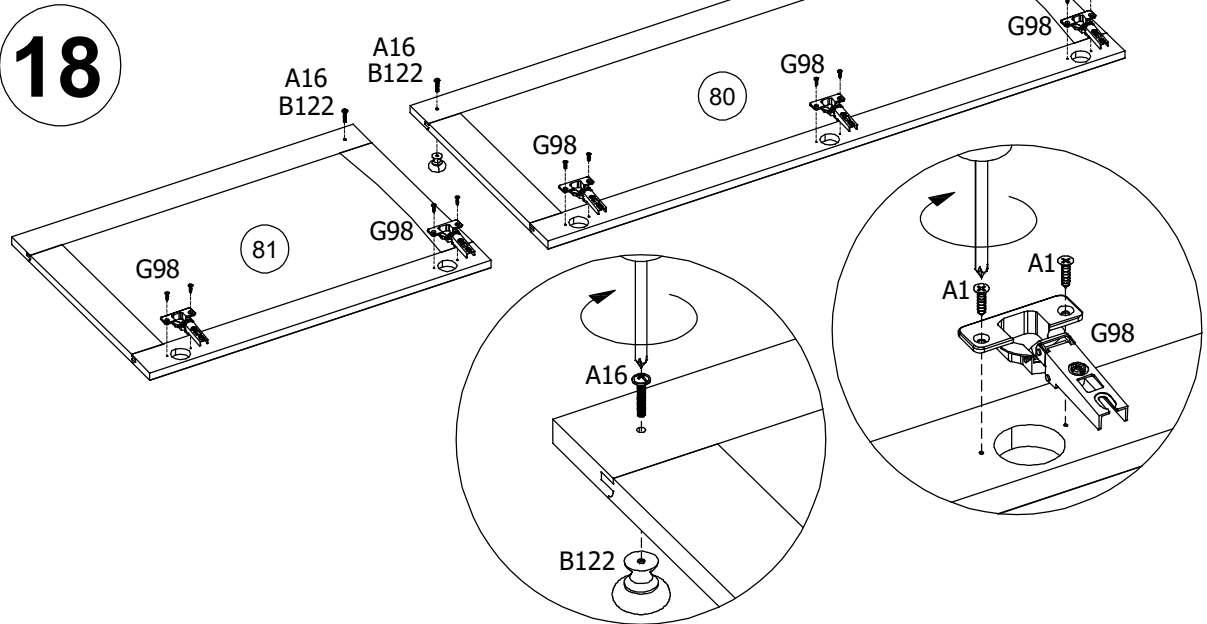

N3		x2 Ø7x1,5
----	--	--------------

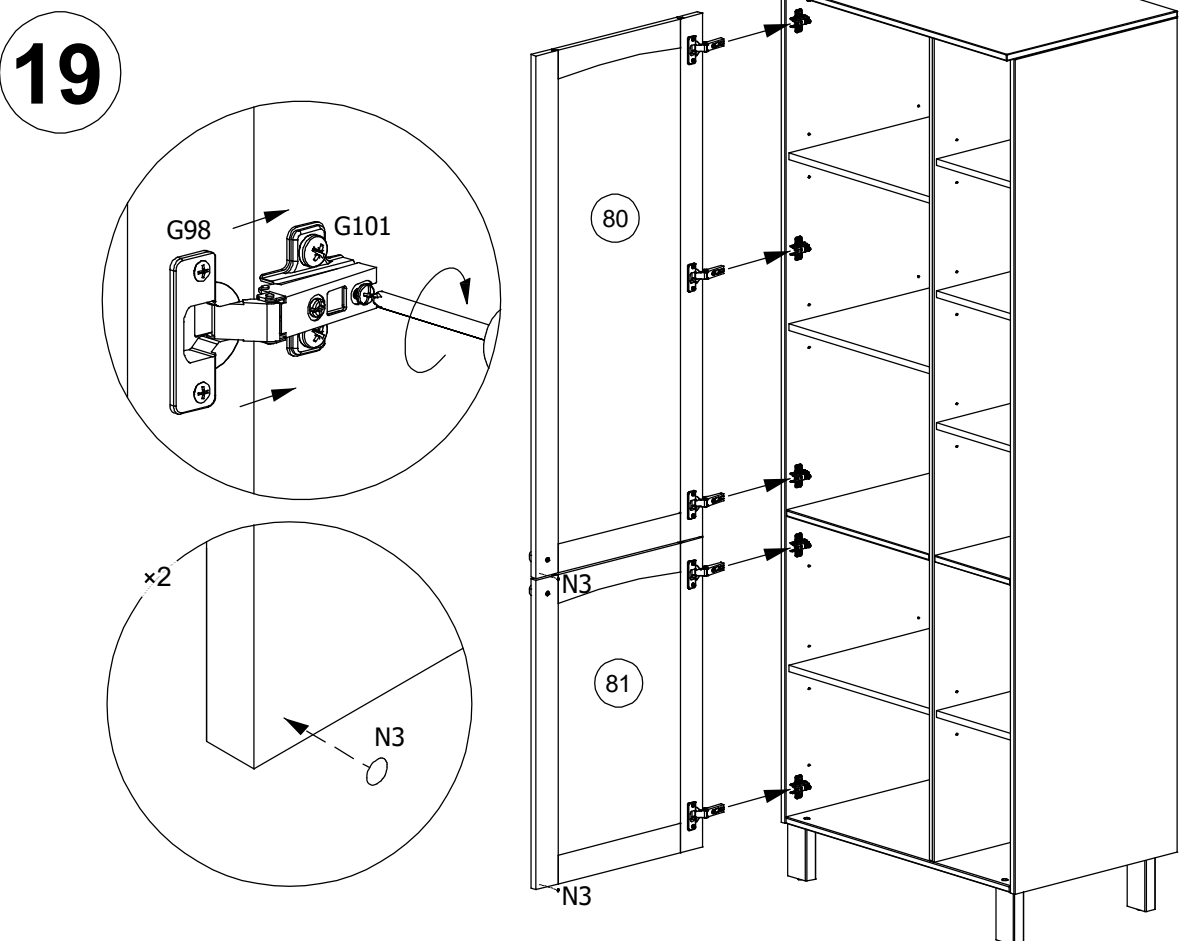

idp68246-1 idp68246-2

H8 

A69 
 ø4x60

 ø6mm

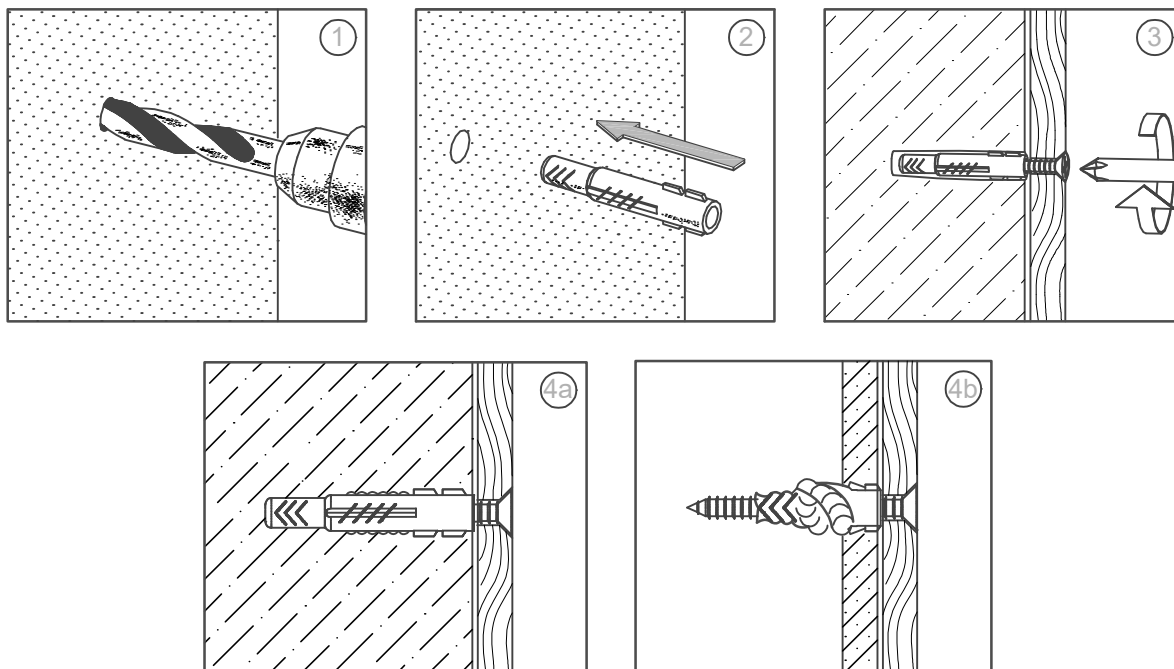

- D** **Achtung:** Die Befestigung des Möbelstückes an der Wand muss von einer fachkundigen Person vorgenommen werden, da für die Montage an die Wand angepasste Dübel erforderlich sind.
- GB** **Attention:** A qualified professional is required when mounting furniture to the wall since dowels corresponding to the wall are required for this.
- FR** **Attention :** La fixation du meuble contre le mur doit être effectuée par une personne compétente car, pour le montage mural, il faut utiliser des chevilles adaptées.
- IT** **Attenzione:** Il fissaggio del mobile alla parete deve essere eseguito da persone esperte, dato che occorrono tasselli adeguati.
- NL** **Opgelet:** een vakkundige persoon dient het meubelstuk aan de muur te bevestigen; voor de montage aan de muur zijn immers aangepaste pluggen vereist.
- PL** **Uwaga:** Mocowanie mebla do ściany mogą przeprowadzić wyłącznie wykwalifikowane osoby, z uwagi na zastosowanie odpowiednio dopasowanych kołków do rodzaju ściany.
- CZ** **Pozor:** Montáž nábytku na stěnu musí provést odborník, protože k montáži na stěnu jsou zapotřebí upravené hmoždinky.
- SK** **Pozor:** Upevnenie nábytku na stenu musí vykonať odborník, nakoľko sú pre montáž na stenu potrebné vhodné hmoždinky.
- HU** **Figyelem:** A bútorelemek falra rögzítését szakembernek kell végeznie, mert a rögzítéshez megfelelő tiplit kell használni.
- RO** **Atenție:** Fixarea la perete a piesei de mobilier se realizează numai de către personal competent, deoarece montajul de perete necesită dibluri adecvate.
- TR** **Dikkat:** Mobilya parçasının duvara sabitlenmesi, duvar montajı için özel uyarlanmış dübeller gerektirdiğinden bu iş sadece bu konuda uzman bir kişi tarafından gerçekleştirilmelidir.
- RU** **Внимание:** Поскольку для монтажа на стене необходимо использовать специальные дюбели, мебель должна быть закреплена на стене квалифицированным персоналом.
- LV** **Uzmanību:** Mēbeles montāžai pie sienas paredzēts izmantot speciālus dībeļus. Ietecams šo darbu veikt kvalificētam darbiniekam.

- ⒸZ) Úprava dverí
- Ⓓ) Das Richten einer Türe
- Ⓕ) Réglage d'une porte.
- ⒽU) Beállítás egy ajtó
- Ⓘ) Regolare una porta
- ⒻV) Durvju regulēšana
- ⒼNL) Instellen van een deur
- ⒼPL) Regulacja drzwi
- ⒼRO) Reglarea o ușă
- ⒼRU) Регулировка Дверей
- ⒼSK) Úprava dverí
- ⒼTR) Bir kapı ayarlama
- ⒼUK) Adjusting a door
- ⒼFIN) Oven säätö

