

DE	Gebrauchsanleitung / Montageanleitung
FR	Mode d'emploi / Instructions de montage
EN	Instructions for use / assembly instructions
IT	Istruzioni per l'uso / Istruzioni per Installazione
ES	Modo de empleo / Instrucciones de montaje
NL	Gebruiksaanwijzing / Handleiding
DK	Brugsanvisning / Monteringsvejledning
PT	Instruções para uso / Manual de Instalação
PL	Instrukcja obsługi / Instrukcja montażu
CS	Návod k použití / Montážní návod
SK	Návod na použitie / Montážny návod
ZH	用户手册 / 组装说明
RU	Руководство пользователя / Инструкция по монтажу
FI	Käyttöohje / Asennusohje
SV	Bruksanvisning / Monteringsanvisning
LT	Vartotojo instrukcija / Montavimo instrukcija
HR	Upute za uporabu / Uputstva za instalaciju
TR	Kullanım kılavuzu / Montaj kılavuzu
RO	Manual de utilizare / Instrucțiuni de montare
EL	Οδηγίες χρήσης / Οδηγία συναρμολόγησης
SL	Navodilo za uporabo / Navodila za montažo
ET	Kasutusjuhend / Paigaldusjuhend
LV	Lietošanas pamācība / Montāžas instrukcija
SR	Uputstvo za upotrebu / Uputstvo za montažu
NO	Bruksanvisning / Montasjeveiledning
BG	Инструкция за употреба / Ръководство за монтаж
SQ	Udhëzuesi i përdorimit / Udhëzime rreth montimit
AR	دليل الاستخدام / تعليمات التجميع
HU	Használati útmutató / Szerelési útmutató
JP	取扱説明書 / 施工説明書

2
3
4
5
6
7
8
9
10
11
12
13
14
15
16
17
18
19
20
21
22
23
24
25
26
27
28
29
30
32

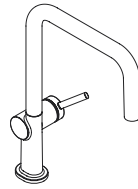

Talis M54 U 220
1jet
72806XXX

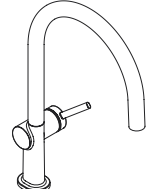

Talis M54 220
1jet
72804XXX

Talis M54 U 220
Eco 1jet
72844XXX

Talis M54 220
Eco 1jet
72843XXX

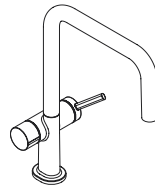

Talis M54 220
1jet
72807XXX

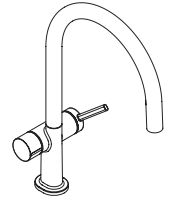

Talis M54 220
1jet
72805XXX

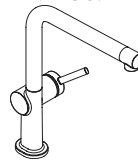

Talis M54 270
1jet
72840XXX

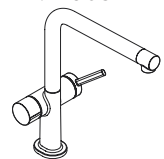

Talis M54 270
1jet
72827XXX



Accepterad
monteringsanvisning
2021:1



Sicherheitshinweise

- Bei der Montage müssen zur Vermeidung von Quetsch- und Schnittverletzungen Handschuhe getragen werden.
- Große Druckunterschiede zwischen den Kalt- und Warmwasseranschlüssen müssen ausgeglichen werden.

Montagehinweise

- Vor der Montage muss das Produkt auf Transportschäden untersucht werden. Nach dem Einbau werden keine Transport- oder Oberflächenschäden anerkannt.
- Die Leitungen und die Armatur müssen nach den gültigen Normen montiert, gespült und geprüft werden.
- Die in den Ländern jeweils gültigen Installationsrichtlinien sind einzuhalten.
- 72805XXX, 72807XXX, 72827XXX:** Nur Spül- oder Waschmaschinen die das DVGW-Zeichen führen, dürfen ohne Zusatzsicherung an das Geräteanschlussventil angeschlossen werden.
- 72843XXX, 72844XXX:** Die Armatur kann nicht in Verbindung mit einem Durchlauferhitzer verwendet werden.

Technische Daten

Betriebsdruck: max. 1 MPa
 Empfohlener Betriebsdruck: 0,1 - 0,5 MPa
 Prüfdruck: 1,6 MPa
 (1 MPa = 10 bar = 147 PSI)

Heißwassertemperatur: max. 60°C
 Thermische Desinfektion: 70°C / 4 min

Das Produkt ist ausschließlich für Trinkwasser konzipiert!

Symbolerklärung



Kein essigsäurehaltiges Silikon verwenden!



Justierung (siehe Seite 38)

Einstellen der Warmwasserbegrenzung. In Verbindung mit Durchlauferhitzern ist eine Warmwassersperre nicht zu empfehlen.



Maße (siehe Seite 40)



Durchflussdiagramm

(siehe Seite 40)



Serviceteile (siehe Seite 53)

XXX = Farbcodierung
 000 = Chrom
 670 = Mattschwarz
 800 = Edelstahl-Optik

Sonderzubehör

(nicht im Lieferumfang enthalten)



Adapter (G^{3/8} / G^{1/2})
 #93395000 (siehe Seite 51 / 52)



Reinigung (siehe Seite 46)



Bedienung (siehe Seite 39)

Hansgrohe empfiehlt, morgens oder nach längeren Stagnationszeiten den ersten halben Liter nicht als Trinkwasser zu verwenden.



Prüfzeichen (siehe Seite 56)

Störung	Ursache	Abhilfe
Armatur schwergängig	- Kartusche defekt, verkalkt	- Kartusche austauschen
Armatur tropft	- Kartusche defekt	- Kartusche austauschen
Wasseraustritt am Befestigungsschaft	- Anschlusschläuche nicht ganz in den Grundkörper eingeschraubt	- Anschlusschläuche von Hand festziehen
	- O-Ring am Anschluss Schlauch defekt	- O-Ring austauschen
Zu niedrige Warmwassertemperatur	- Warmwasserbegrenzung falsch eingestellt	- Warmwasserbegrenzung einstellen





Consignes de sécurité

- ⚠ Lors du montage, porter des gants de protection pour éviter toute blessure par écrasement ou coupure.
- ⚠ Il est conseillé d'équilibrer les pressions de l'eau chaude et froide.

Instructions pour le montage

- Avant son montage, s'assurer que le produit n'a subi aucun dommage pendant le transport. Après le montage, tout dommage de transport ou de surface ne pourra pas être reconnu.
- Les conduites et la robinetterie doivent être montés, rincés et contrôlés selon les normes en vigueur.
- Les directives d'installation en vigueur dans le pays concerné doivent être respectées.
- **72805XXX, 72807XXX, 72827XXX**: Seuls les lave-vaisselle ou machines à laver portant le sigle DVGW, doivent être reliés sans fusible supplémentaire au raccord de l'appareil.
- **72843XXX, 72844XXX**: Le robinet ne fonctionne pas avec une production d'eau chaude instantanée.

Informations techniques

Pression de service autorisée: max. 1 MPa
 Pression de service conseillée: 0,1 - 0,5 MPa
 Pression maximum de contrôle: 1,6 MPa
 (1 MPa = 10 bar = 147 PSI)
 Température d'eau chaude: max. 60 °C
 Désinfection thermique: 70 °C / 4 min

Le produit est exclusivement conçu pour de l'eau potable!

Description du symbole



Ne pas utiliser de silicone contenant de l'acide acétique!



Etalonnage (voir pages 38)

Réglage de la limitation d'eau chaude. En liaison avec les chauffe-eau, un blocage de l'eau chaude n'est pas recommandable.



Dimensions (voir pages 40)



Diagramme du débit

(voir pages 40)



Pièces détachées (voir pages 53)

XXX = Couleurs
 000 = Chromé
 670 = Matt Black
 800 = Aspect Acier Inox

Accessoires en option

(ne fait pas partie de la fourniture)



Adaptateur (G^{3/8} / G^{1/2})
 #93395000 (voir pages 51 / 52)



Nettoyage (voir pages 46)



Instructions de service

(voir pages 39)

Hansgrohe recommande de ne pas utiliser le premier demi-litre le matin ou après une période de stagnation prolongée.



Classification acoustique et débit

(voir pages 56)

Dysfonctionnement	Origine	Solution
Durété de fonctionnement	- Cartouche défectueuse, entartrée	- Changer la cartouche
Le mitigeur goutte	- Cartouche défectueuse	- Changer la cartouche
Fuite à la fixation sous le mitigeur	- Les flexibles de raccordement ne sont pas correctement vissés dans le corps.	- Resserrer le flexible à la main.
	- Joint torique sous les flexible de raccords défectueux	- Changer le joint torique
Température d'eau chaude trop basse, pas d'eau froide	- Limiteur de température mal positionné	- Positionner le limiteur de température



Safety Notes

- △ Gloves should be worn during installation to prevent crushing and cutting injuries.
- △ The hot and cold supplies must be of equal pressures.

Installation Instructions

- Prior to installation, inspect the product for transport damages. After it has been installed, no transport or surface damage will be honoured.
- The pipes and the fixture must be installed, flushed and tested as per the applicable standards.
- The plumbing codes applicable in the respective countries must be observed.
- **72805XXX, 72807XXX, 72827XXX:** Only dishwashers and washing machines certified with the DVGW emblem may be connected to the appliance connection valve without an additional fuse.
- **72843XXX, 72844XXX:** The mixer can not used together with a continuous flow water heater.

Technical Data

Operating pressure: max. 1 MPa
 Recommended operating pressure: 0,1 - 0,5 MPa
 Test pressure: 1,6 MPa
 (1 MPa = 10 bar = 147 PSI)

Hot water temperature: max. 60 °C
 Thermal disinfection: 70 °C / 4 min

The product is exclusively designed for drinking water!

Symbol description



Do not use silicone containing acetic acid!



Adjustment (see page 38)

To adjust the hot water limiter. Using a hot water limiter in combination with a continuous flow water heater is not recommended.



Dimensions (see page 40)



Flow diagram (see page 40)



Spare parts (see page 53)

XXX = Colors
 000 = Chrome Plated
 670 = Matt Black
 800 = Stainless Steel Optic

Special accessories (order as an extra)



Adapter (G³/₈ / G¹/₂)
 #93395000 (see page 51 / 52)



Cleaning (see page 46)



Operation (see page 39)

Hansgrohe recommends not to use as drinking water the first half liter of water drawn in the morning or after a prolonged period of non-use.



Test certificate (see page 56)

Fault	Cause	Remedy
Mixer stiff	- Cartridge defective, calcified	- Exchange cartridge
Mixer dripping	- Cartridge defective	- Exchange cartridge
Water escaping at the threaded base	- connection hoses not completely screwed into basic body	- Tighten connection hoses by hand
	- O-ring at the connection hose defective.	- Exchange O-ring
Hot water temperature too low	- Hot water limiter incorrectly set	- Set hot water limiter



Indicazioni sulla sicurezza

- ⚠ Durante il montaggio, per evitare ferite da schiacciamento e da taglio bisogna indossare guanti protettivi.
- ⚠ Attenzione! Compensare le differenze di pressione tra i collegamenti dell'acqua fredda e dell'acqua calda.

Istruzioni per il montaggio

- Prima del montaggio è necessario controllare che non ci siano stati danni durante il trasporto. Una volta eseguito il montaggio, non verranno riconosciuti eventuali danni di trasporto o delle superfici.
- Montare, lavare e controllare tubature e rubinetteria rispettando le norme correnti.
- Vanno rispettate le direttive di installazione nazionali vigenti nel rispettivo paese.
- **72805XXX, 72807XXX, 72827XXX:** Solo le lavastoviglie e lavatrici con il marchio DVGW si possono collegare senza fusibile supplementare con la valvola di collegamento dell'apparecchio.
- **72843XXX, 72844XXX:** Il rubinetto non può essere utilizzato insieme ad uno scaldacqua istantaneo.

Dati tecnici

Pressione d'uso: max. 1 MPa
 Pressione d'uso consigliata: 0,1 - 0,5 MPa
 Pressione di prova: 1,6 MPa
 (1 MPa = 10 bar = 147 PSI)
 Temperatura dell'acqua calda: max. 60°C
 Disinfezione termica: 70°C / 4 min
 Il prodotto è concepito esclusivamente per acqua potabile!

Descrizione simbolo



Non utilizzare silicone contenente acido acetico!



Taratura (vedi pagg. 38)

Regolazione del limitatore di erogazione d'acqua calda. Un limitatore di erogazione di acqua calda in combinazione con le caldaie istantanee non è consigliabile.



Ingombri (vedi pagg. 40)



Diagramma flusso (vedi pagg. 40)



Parti di ricambio (vedi pagg. 53)

XXX = Trattamento
 000 = Cromato
 670 = Matt Black
 800 = Acciaio Inox Acciaio

Accessori speciali

(non contenuto nel volume di fornitura)



Adattatore (G^{3/8} / G^{1/2})
 #93395000 (vedi pagg. 51 / 52)



Pulitura (vedi pagg. 46)



Procedura (vedi pagg. 39)

Hansgrohe raccomanda, di mattina oppure dopo lunghi tempi di stagnazione, di non utilizzare il primo mezzo litro come acqua potabile.



Segno di verifica (vedi pagg. 56)

Problema	Possibile causa	Rimedio
Miscelatore duro	- Cartuccia difettosa	- Sostituire la cartuccia
Miscelatore gocciola	- Cartuccia difettosa	- Sostituire la cartuccia
Perdita di acqua al set di fissaggio	- I raccordi dei flessibili avvitati male nel corpo incasso	- Avvitare i raccordi flessibili a mano
	- O-ring al raccordo flessibile difettoso	- Sostituire l'o-ring
Temperatura dell'acqua calda	- Limitazione dell'acqua calda regolata male	- Regolare la limitazione dell'acqua calda



Indicaciones de seguridad

- △ Durante el montaje deben utilizarse guantes para evitar heridas por aplastamiento o corte.
- △ Grandes diferencias de presión en servicio entre agua fría y agua caliente deben equilibrarse.

Indicaciones para el montaje

- Antes del montaje se debe examinar el producto contra daños de transporte. Después de la instalación no se reconoce ningún daño de transporte o de superficie.
- Los conductos y la grifería deben montarse, lavarse y comprobarse según las normas vigentes.
- Es obligatorio el cumplimiento de las directrices de instalación vigentes en el país respectivo.
- **72805XXX, 72807XXX, 72827XXX:** Sin seguro adicional, solo está permitido conectar a la válvula de conexión de aparatos, los lavavajillas y las lavadoras que lleven incorporado el sello DVGW (Asociación alemana de especialistas en instalaciones de gas y agua).
- **72843XXX, 72844XXX:** Este grifo no es apto en combinación con un calentador continuo.

Datos técnicos

Presión en servicio:	max. 1 MPa
Presión recomendada en servicio:	0,1 - 0,5 MPa
Presión de prueba:	1,6 MPa
	(1 MPa = 10 bar = 147 PSI)
Temperatura del agua caliente:	max. 60 °C
Desinfección térmica:	70 °C / 4 min

El producto ha sido concebido exclusivamente para agua potable.

Descripción de símbolos



No utilizar silicona que contiene ácido acético!



Ajuste (ver página 38)

Ajuste del límite de agua caliente. En combinación con calentadores continuos no es recomendable utilizar un bloqueo de agua caliente.



Dimensiones (ver página 40)



Diagrama de circulación (ver página 40)



Repuestos (ver página 53)

XXX = Acabados
000 = Cromado
670 = Matt Black
800 = Acero Especial

Opcional (no incluido en el suministro)



Adaptador (G³/₈ / G¹/₂)
#93395000 (ver página 51 / 52)



Limpiar (ver página 46)



Manejo (ver página 39)

Hansgrohe recomienda no utilizar el primer medio litro como agua potable por las mañanas o tras un largo periodo de inactividad.



Marca de verificación (ver página 56)

Problema

Causa

Solución

Manecilla va dura	- cartucho dañado	- cambiar el cartucho
Grifo pierde agua	- cartucho dañado	- cambiar el cartucho
Pérdida de agua en el set de fijación	- Conexión flexible mal atornillada al cuerpo del caño.	- Apretar a mano la conexión flexible
	- Daños en la junta de la conexión flexible	- cambiar juntas
Temperatura del agua caliente demasiado baja	- tope de agua caliente mal	- ajustar tope





Veiligheidsinstructies

- △ Bij de montage moeten ter voorkoming van knel- en snijwonden handschoenen worden gedragen.
- △ Grote drukverschillen tussen de koud- en warmwater-toevoer dienen vermeden te worden.

Montage-instructies

- Vóór de montage moet het product gecontroleerd worden op transportschade. Na de inbouw wordt geen transport- of oppervlakteschade meer aanvaard.
- De leidingen en armaturen moeten gemonteerd, gespoeld en gecontroleerd worden volgens de geldige normen.
- De in de overeenkomstige landen geldende installatierichtlijnen moeten nageleefd worden.
- **72805XXX, 72807XXX, 72827XXX:** Enkel vaatwas- of wasmachines die beschikken over het DVGW-kenmerk, mogen zonder extra beveiliging aangesloten worden aan de aansluitklep van het apparaat.
- **72843XXX, 72844XXX:** Het artikel kan niet in combinatie met een doorstroomtoestel toegepast worden.

Technische gegevens

Werkdruk: max. 1 MPa
 Aanbevolen werkdruk: 0,1 - 0,5 MPa
 Getest bij: 1,6 MPa
 (1 MPa = 10 bar = 147 PSI)

Temperatuur warm water: max. 60°C
 Thermische desinfectie: 70°C / 4 min

Het product is uitsluitend ontworpen voor drinkwater!

Symboolbeschrijving

 Gebruik geen zuurhoudende silicone!

Storing	Oorzaak	Oplossing
Bediening zwaar	- Kardoes defect of verkakt	- Kardoes uitwisselen
Mengkraan lekt	- Kardoes defect	- Kardoes uitwisselen
Lekkage op montageschacht	- Aansluitslangen niet geheel in kraanhuis vastgedraaid	- Aansluitslangen handvast aandraaien
	- O-ring van aansluitlang defect	- O-ring uitwisselen
Temperatuur van warm water te laag	- Heetwaterbegrenzer verkeerd ingesteld	- Heetwaterbegrenzer instellen

Instellen (zie blz. 38)

Instellen van de warmwaterbegrenzing. In combinatie met een doorstroomer is een warmwaterblokkering niet aanbevelenswaardig.

Maten (zie blz. 40)

Doorstroomdiagram (zie blz. 40)

Service onderdelen (zie blz. 53)

XXX = Kleuren
 000 = Verchroomd
 670 = Matt Black
 800 = RVS-look

Toebehoren

(behoort niet tot het leveringspakket)

 Adapter (G^{3/8} / G^{1/2})
 #93395000 (zie blz. 51 / 52)

Reinigen (zie blz. 46)

Bediening (zie blz. 39)

Hansgrohe raadt aan om 's morgens na langere stagnatietijden de eerste halve liter niet als drinkwater te gebruiken.

Keurmerk (zie blz. 56)



Sikkerhedsanvisninger

- ⚠ Ved monteringen skal der bruges handsker for at undgå kvæstelser og snitsår.
- ⚠ Større trykforskelle mellem koldt og varmt vand bør udjævnes.

Monteringsanvisninger

- Før monteringen skal produktet kontrolleres for transportskader. Efter monteringen godkendes transportskader eller skader på overfladen ikke længere.
- Ledningerne og armaturerne skal monteres, skylles og kontrolleres iht. de gældende standarder.
- Installationsbestemmelserne, der gælder i det enkelte land, skal overholdes.
- **72805XXX, 72807XXX, 72827XXX:** Du må kun tilslutte opvaksemaskiner og vaskemaskiner med DVGW-tegn uden ekstra sikring til apparatets tilslutningsventil.
- **72843XXX, 72844XXX:** Armaturet bør ikke anvendes i forbindelse med en gennemstrømningsvandvarmer.

Tekniske data

Driftstryk:	max. 1 MPa
Anbefalet driftstryk:	0,1 - 0,5 MPa
Prøvetryk:	1,6 MPa (1 MPa = 10 bar = 147 PSI)
Varmtvandstemperatur:	max. 60 °C
Termisk desinfektion:	70 °C / 4 min

Produktet er udelukkende beregnet til drikkevand!

Symbolbeskrivelse



Der må ikke benyttes eddikesyreholdig silikone!



Forindstilling (se s. 38)

Indstilling af varmvandsbegrænsningen. I forbindelse med gennemstrømningsvandvarmere anbefaler vi ikke en varmvandsspærre.



Målene (se s. 40)



Gennemstrømningsdiagram (se s. 40)



Reserve dele (se s. 53)

XXX = Overflade
 000 = Krom
 670 = Matt Black
 800 = Stainless Steel Optic

Specialtilbehør (ikke med i leveringsomfang)



Adapter (G³/₈ / G¹/₂)
 #93395000 (se s. 51 / 52)



Rengøring (se s. 46)



Brugsanvisning (se s. 39)

Hansgrohe anbefaler at den første halve liter om morgenen eller efter længere stagneringstider ikke anvendes som drikkevand.



Godkendelse (se s. 56)

Fejl	Årsag	Hjælp
Grebet går trægt	- Kartusche defekt, tilkalket	- Udskift kartusche
Armaturet drypper	- Defekt kartusche	- Udskift kartusche
Armaturet er utæt ved befæstelsesdelene	- Tilslutningsslangerne er ikke skruet korrekt op i armaturet.	- Med håndkraft skures tilslutnings-slangen strammere på.
	- Defekt o-ring på tilslutningsslange	- Udskift o-ring
For lav varmvands-temperatur	- Varmtvandsbegrænsningen er forkert indstillet	- Indstil varmvandsbe-grænsningen





Avisos de segurança

- ⚠ Durante a montagem devem ser utilizadas luvas de protecção, de modo a evitar ferimentos resultantes de entalamentos e de cortes.
- ⚠ Grandes diferenças entre as pressões das águas quente e fria devem ser compensadas.

Avisos de montagem

- Antes da montagem deve-se controlar o produto relativamente a danos de transporte. Após a montagem não são aceites quaisquer danos de transporte ou de superfície.
- As tubagens e a torneira têm que ser montadas, enxaquadas e verificadas de acordo com as normas em vigor.
- A prescrições de instalação válidas nos respetivos países devem ser respeitadas.
- **72805XXX, 72807XXX, 72827XXX:** Apenas as máquinas de lavar loiça ou as máquinas de lavar roupa que têm a posto o símbolo DVGW podem ser conectadas à válvula de ligação do aparelho, sem a utilização de um dispositivo de protecção complementar.
- **72843XXX, 72844XXX:** A misturadora não pode ser utilizada com esquentadores instantâneos ou caldeira.

Dados Técnicos

Pressão de funcionamento: max. 1 MPa
 Pressão de func. recomendada: 0,1 - 0,5 MPa
 Pressão testada: 1,6 MPa
 (1 MPa = 10 bar = 147 PSI)

Temperatura da água quente: max. 60 °C
 Desinfecção térmica: 70 °C / 4 min

Este produto foi única e exclusivamente concebido para água potável!

Descrição do símbolo



Não utilizar silicone que contenha ácido acético!



Afinação (ver página 38)

Ajuste do limitador de água quente. Em combinação com um esquentador, não é recomendável o uso de um bloqueio de água quente.



Medidas (ver página 40)



Fluxograma (ver página 40)



Peças de substituição (ver página 53)

XXX = Acabamentos
 000 = Cromado
 670 = Matt Black
 800 = Aço Imaculado Ótica

Acessórios especiais

(não incluído no volume de fornecimento)



Adaptador (G $\frac{3}{8}$ / G $\frac{1}{2}$)
 #93395000 (ver página 51 / 52)



Limpeza (ver página 46)



Funcionamento (ver página 39)

A Hansgrohe recomenda a não utilização do primeiro meio litro de água, de manhã ou após longas paragens, para fins de consumo.



Marca de controlo (ver página 56)

Falha	Causa	Solução
Misturadora perra	- Cartucho defeituoso, calcificado	- Substituir o cartucho
Misturadora a pingar	- Cartucho defeituoso	- Substituir o cartucho
Perde água pela base roscada	- Tubos de ligação não estão completamente enroscados	- Apertar os tubos de ligação à mão
	- O-ring dos tubo de ligação defeituoso	- Trocar o-ring
Temperatura da água quente muito baixa	- O limitador de temperatura está incorrectamente colocado	- Regular o limitador de temperatura



Wskazówki bezpieczeństwa

- △ Aby uniknąć zranień na skutek zgniecenia lub przecięcia, podczas montażu należy nosić rękawice ochronne.
- △ Znaczne różnice ciśnień na doptywach ciepłej i zimnej wody muszą zostać wyrównane.

Wskazówki montażowe

- Przed montażem należy skontrolować produkt pod kątem szkód transportowych. Po montażu nie widać żadnych szkód transportowych ani szkód na powierzchni.
- Przewody i armatura muszą być montowane, płukane i kontrolowane według obowiązujących norm.
- Należy przestrzegać wytycznych instalacyjnych obowiązujących w danym kraju.
- **72805XXX, 72807XXX, 72827XXX:** Bez dodatkowego zabezpieczenia do zaworu przyłączeniowego urządzenia można podłączyć jedynie zmywarkę lub pralkę posiadającą znaczek DVGW.
- **72843XXX, 72844XXX:** Armatura nie może współpracować z przepływowymi podgrzewaczami wody.

Dane techniczne

Ciśnienie robocze:	maks. 1 MPa
Zalecane ciśnienie robocze:	0,1 - 0,5 MPa
Ciśnienie próbne:	1,6 MPa
	(1 MPa = 10 bary = 147 PSI)
Temperatura wody gorącej:	maks. 60 °C
Dezynfekcja termiczna:	70 °C / 4 min
Produkt przeznaczony wyłącznie do wody pitnej!	

Opis symbolu



Nie stosować silikonów zawierających kwas octowy!



Ustawianie (patrz strona 38)

Ustawianie ogranicznika ciepłej wody. Używanie ogranicznika temperatury wody w połączeniu z przepływowym podgrzewaczem wody nie jest zalecane.



Wymiary (patrz strona 40)



Schemat przepływu (patrz strona 40)



Części serwisowe (patrz strona 53)

XXX = Kody kolorów
000 = Chrom
670 = Matt Black
800 = Stal Szlachetna

Wyposażenie specjalne

(Nie jest częścią dostawy)



Prześciółka (G^{3/8} / G^{1/2})
#93395000 (patrz strona 51 / 52)



Czyszczenie (patrz strona 46)



Obsługa (patrz strona 39)

Hansgrohe zaleca, by z rana lub po dłuższym czasie niekorzystania, pierwsze pół litra wody nie używać jako wody pitnej.



Znak jakości (patrz strona 56)

Usterka

Przyczyna

Pomoc

Uchwyt armatury pracuje z wysiłkiem	- Uszkodzony wkład, zakamieniony	- Wymiana wkładu
Armatura cieknie	- Uszkodzony wkład	- Wymiana wkładu
Wyciek wody przy mocowaniu od dołu	- Zbyt słabo wkręcone wężyki w korpus - Uszkodzony o-ring przy wężu przyłączeniowym	- Dokręcić wężyki - Wymienić o-ring
Za niska temperatura ciepłej wody	- Niewłaściwe ustawienie ogranicz-	- Ustawić ogranicznik ciepłej wody
	nik ciepłej wody	



Bezpečnostní pokyny

- △ Pro zabránění řezným zraněním a pohmožděninám je nutné při montáži nosit rukavice.
- △ Je nutné vyrovnat velké rozdíly tlaku mezi přípoji studené a teplé vody.

Pokyny k montáži

- Před montáží je třeba produkt zkontrolovat, zda nebyl při transportu poškozen. Po zabudování nebudou uznány žádné škody způsobené transportem nebo poškození povrchu.
- Vedení a armatura musí být namontovány, propláchnuty a otestovány podle platných norem.
- Je třeba dodržovat montážní pravidla platné v dané zemi.
- **72805XXX, 72807XXX, 72827XXX:** Na ventil pro připojení zařízení se smí bez přídavné pojistky připojit jen myčky nebo pračky se značkou DVGW.
- **72843XXX, 72844XXX:** Armatura se nesmí používat v kombinaci s průtokovým ohřivačem.

Technické údaje

Provozní tlak:	max. 1 MPa
Doporučený provozní tlak:	0,1 - 0,5 MPa
Zkušební tlak:	1,6 MPa (1 MPa = 10 bar = 147 PSI)
Teplota horké vody:	max. 60 °C
Teplotná desinfekce:	70 °C / 4 min

Výrobky Hansgrohe jsou vhodné pro přímý kontakt s pitnou vodou.

Popis symbolů



Nepoužívat silikon s obsahem kyseliny octové!



Nastavení (viz strana 38)

Nastavení omezovače teplé vody. Ve spojení s průtokovým ohřivačem se použití uzávěru teplé vody nedoporučuje.



Rozměry (viz strana 40)



Diagram průtoku (viz strana 40)



Servisní díly (viz strana 53)

XXX = Kód povrchové úpravy
000 = Chrom
670 = Matt Black
800 = Nerezová Ocel

Zvláštní příslušenství

(není součástí dodávky)



Adaptér (G³/₈ / G¹/₂)
#93395000 (viz strana 51 / 52)



Čištění (viz strana 46)



Ovládání (viz strana 39)

Hansgrohe doporučuje ráno nebo po delších přestávkách nepoužívat prvního půl litru jako pitnou vodu.



Zkušební značka (viz strana 56)

Porucha	Příčina	Odstranění
Armatura jde ztěžka	- Kartuše je vadná, zanesená vodním kamenem	- Kartuši vyměnit
Armatura odkapává	- Kartuše je vadná	- Kartuši vyměnit
výstup vody na upevňovacím násadci	- přípojovací hadice nejsou dostatečně zašroubovány do tělesa - O-kroužek na přípojovací hadici je defektní	- přípojovací hadice utáhnout rukou - vyměnit O-kroužek
Nízká teplota teplé vody	- Špatně nastavená zarážka pro teplotu vodu	- Seřídít zarážku pro teplotu vodu



Bezpečnostné pokyny

- △ Pri montáži musíte nosiť rukavice, aby ste predišli pomliaždeninám a rezným poraneniam.
- △ Veľké rozdiely v tlaku medzi prípojkami studenej a teplej vody musia byť vyrovnané.

Pokyny pre montáž

- Pred montážou musíte produkt skontrolovať, či nebol počas transportu poškodený. Po zabudovaní nebudú uznané žiadne škody spôsobené transportom alebo poškodenia povrchu.
- Potrubia a vybavenie musia byť namontované, prepláchnuté a vybavené v platnom normami.
- Je potrebné dodržiavať smernice o inštalácii, ktoré sú práve teraz platné v krajinách.
- **72805XXX, 72807XXX, 72827XXX:** K ventilu pripojenia zariadení je možné bez dodatočného zaistenia pripojiť len umýv ačku riadu alebo práčku so značkou DVGW.
- **72843XXX, 72844XXX:** Armatúra sa nesmie používať v kombinácii s prietokovým ohrievačom.

Technické údaje

Prevádzkový tlak:	max. 1 MPa
Doporučený prevádzkový tlak:	0,1 - 0,5 MPa
Skúšobný tlak:	1,6 MPa (1 MPa = 10 bar = 147 PSI)
Teplota teplej vody:	max. 60 °C
Termická dezinfekcia:	70 °C / 4 min

Výrobok je koncipovaný výhradne pre pitnú vodu!

Popis symbolov



Nepoužívať silikón s obsahom kyseliny octovej!



Nastavenie (viď strana 38)

Nastavenie obmedzenia teplej vody. V spojení s prietokovými ohrievačmi sa neodporúča použitie obmedzovača teplej vody.



Rozmery (viď strana 40)



Diagram prietoku (viď strana 40)



Servisné diely (viď strana 53)

XXX = Farebné označenie
000 = Chróm
670 = Matt Black
800 = Ušľachtilá Oceľ

Zvláštne prísľušenstvo

(nie je súčasťou dodávky)



Adaptér (G^{3/8} / G^{1/2})
#93395000 (viď strana 51 / 52)



Čistenie (viď strana 46)



Obsluha (viď strana 39)

Hansgrohe odporúča ráno a po dlhších dobách odstávky nepoužiť prvého pol litra vody ako pitnú vodu.



Osvedčenie o skúške (viď strana 56)

Porucha	Príčina	Pomoc
Armatúra "chodí" ťažko	- Kartuša je poškodená, vápenaté usadeniny	- Vymeniť kartušu
Z armatúry kvapká voda	- Kartuša je poškodená	- Vymeniť kartušu
Uhajanie vode ob pritržilnem nastavku	- Hadice pripojenia nie sú celkom zaskrutkované do základného telesa - Chybný O krúžok na pripojovacej hadici	- Hadice pripojenia dotiahnuť ručne - Vymeniť O krúžok
Nízka teplota teplej vody	- Nesprávne nastavená zarážka na	- Nastavenie zarážky na teplú vodu





安全技巧

- △ 装配时为避免挤压和切割受伤，必须戴上手套。
- △ 冷热水管间过大的压力差必须予以平衡。

安装提示

- 安装前必须检查产品是否受到运输损害。安装后将不认可运输损害或表面损伤。
- 管道和阀门必须根据通用标准进行安装、冲洗和检查。
- 请遵守当地国家现行的安装规定。
- **72805XXX, 72807XXX, 72827XXX:** 只有那些带有DVGW标记的洗衣机或洗碗机才可以不需附加其他安全设备而直接连接到本产品的外接设备供水网上。
- **72843XXX, 72844XXX:** 阀门不可与即热式热水器连接使用。

技术参数

工作压强: 最大 1 MPa
 推荐工作压强: 0,1 - 0,5 MPa
 测试压强: 1,6 MPa
 (1 MPa = 10 bar = 147 PSI)

热水温度: 最大 60°C
 热力消毒: 70°C / 4 分钟

该产品专为饮用水设计！

符号说明



请勿使用含有乙酸的硅胶！



调节 (参见第页 38)

热水温度调节。如果使用即热式喷头，则不建议安装热水阀门。



大小 (参见第页 40)



流量示意图 (参见第页 40)



备用零件 (参见第页 53)

XXX = 颜色代码
 000 = 镀铬
 670 = Matt Black
 800 = 不锈钢表面

选装附件 (不在供货范围内)



转接器 (G $\frac{3}{8}$ / G $\frac{1}{2}$)
 #93395000 (参见第页 51 / 52)



清洗 (参见第页 46)



操作 (参见第页 39)

汉斯格雅建议，清晨或在水流长时间停滞，前半升水不作饮用水使用。



检验标记 (参见第页 56)

问题	原因	补救
龙头不灵活	- 阀芯损坏, 结垢	- 更换阀芯
龙头滴水	- 阀芯损坏	- 更换阀芯
水从螺纹底座中流出	- 连接软管没有完全旋入基体 - 连接软管的O形环损坏	- 用手拧紧连接软管 - 更换O形环
热水温度过低	- 温度限制器设置错误	- 设置温度限制器



Указания по технике безопасности

- Во время монтажа следует надеть перчатки во избежание прищемления и порезов.
- донного клапа. Перед установкой смесителя необходимо регулировочными кранами выровнять давление холодной и горячей воды при помощи вентилей регулирующих подачу воды в квартиру.

Указания по монтажу

- Перед монтажом следует проверить изделие на предмет повреждений при перевозке. После монтажа претензии о возмещении ущерба за повреждения при перевозке или повреждения поверхностей не принимаются.
- Трубы и арматура должны быть установлены, промыты и проверены в соответствии с действующими нормами.
- Необходимо соблюдать требования по монтажу, действующие в соответствующих странах.
- 72805XXX, 72807XXX, 72827XXX:** Без дополнительного предохранителя к вентилю для подключения приборов разрешается подключать только посудомоечные или стиральные машины со знаком DVGW.
- 72843XXX, 72844XXX:** Применение арматуры при наличии проточного нагревателя не допускается.

Технические данные

Рабочее давление: не более, 1 МПа
 Рекомендуемое рабочее давление: 0,1 - 0,5 МПа
 Давление: 1,6 МПа
 (1 МПа = 10 bar = 147 PSI)
 Температура горячей воды: не более, 60°С
 Термическая дезинфекция: 70°С / 4 мин
 Изделие предназначено исключительно для питьевой воды!

Описание символов



Не применяйте силикон, содержащий уксусную кислоту.



Подгонка (см. стр. 38)

Регулировка ограничителя горячей воды. В сочетании с проточными нагревателями не рекомендуется использовать блокировку воды.



Размеры (см. стр. 40)



Схема потока (см. стр. 40)



Комплект (см. стр. 53)

XXX = Цветная кодировка
 000 = Хром
 670 = Matt Black
 800 = Сталь

Специальные принадлежности

(не включено в объем поставки!)



Переходник (G³/₈ / G¹/₂)
 #93395000 (см. стр. 51 / 52)



Очистка (см. стр. 46)



Эксплуатация (см. стр. 39)

Hansgrohe рекомендует по утрам либо после длительного перерыва в использовании не использовать первые поллитра воды для питья.



Знак технического контроля (см. стр. 56)

Неисправность	Причина	Устранение неисправности
Арматура работает с усилием	- Картридж неисправен, засорение накипью	- Замените картридж
Арматура протекает	- Картридж неисправен	- Замените картридж
Выход воды у основания крепления	- Шланги подключения не полностью завернуты в корпус	- Затяните шланги подключения вручную
	- Уплотнительное кольцо круглого сечения на соединительном шланге неисправно	- Замените уплотнительное кольцо круглого сечения
Температура горячей воды слишком низкая	- Ограничение горячей воды отрегулировано неправильно	- Отрегулируйте ограничение горячей воды





Turvallisuusohjeet

- △ Asennuksessa on käytettävä käsiineitä puristumien ja viiltojen aiheuttamien tapaturmien estämiseksi.
- △ Suuret paine-erot kylmä- ja kuumavesiliitäntöjen välillä on tasattava.

Asennusohjeet

- Ennen asennusta on tarkastettava tuotteen mahdolliset kuljetusvahingot. Asennuksen jälkeen kuljetus- ja pintavaurioita ei hyväksytä.
- Putket ja hana on asennettava, huuhdeltava ja tarkastettava voimassa olevien standardien mukaisesti.
- Jokaisessa maassa on noudatettava siellä päteviä asennusohjeita.
- **72805XXX, 72807XXX, 72827XXX:** Vain sellaiset astian- tai pyykinpesukoneet, joissa on DVGW-merkintä, saa kytkeä ilman lisävarmistusta laiteliittimeen.
- **72843XXX, 72844XXX:** Armaturia ei voi käyttää läpimenvedenkuumentimen yhteydessä.

Tekniset tiedot

Käyttöpaine:	maks. 1 MPa
Suosittelut käyttöpaine:	0,1 - 0,5 MPa
Koestuspaine:	1,6 MPa (1 MPa = 10 bar = 147 PSI)
Kuuman veden lämpötila:	maks. 60 °C
Lämpödesinfektio:	70 °C / 4 min

Tuote on suunniteltu käytettäväksi ainoastaan juomaveden kanssa!

Merkin kuvaus



Älä käytä etikkahappopitoista silikonia!



Säätö (katso sivu 38)

Lämpötilan rajoittimen säätäminen. Emme suosittele käyttämään lämpötilan rajoitinta vedenlämmittimen (läpivirtauskuumennin) yhteydessä.



Mitat (katso sivu 40)



Virtausdiagrammi (katso sivu 40)



Varaosat (katso sivu 53)

XXX = Värikoodaus

000 = Kromi

670 = Matt Black

800 = Inox-Optinen

Erityisvaruste (ei kuulu toimitukseen)



Sovitin (G³/₈ / G¹/₂)

#93395000 (katso sivu 51 / 52)



Puhdistus (katso sivu 46)



Käyttö (katso sivu 39)

Hansgrohe suosittelee, että ensimmäistä puolta litraa ei käytetä juomavetenä aamuisin eikä silloin, kun laitetta ei ole käytetty pitkään aikaan.



Koestusmerkki (katso sivu 56)

Häiriö

Syy

Toimenpide

Hana on raskaskäyttöinen	- Patruuna rikki, kalkkikerrostumia	- Vaihda patruuna
Hanasta tippuu vettä	- Patruuna rikki	- Vaihda patruuna
Vettä valuu kiinnityskauluksesta	- Liitosletkut eivät ole kierretty kiinni perusrunkoon pohjaan asti	- Kierrä liitosletkut kiinni käsikireyteen
	- Liitosletkun O-rengas on rikki	- Vaihda O-rengas
Lämminveden lämpötila liian alhainen	- Lämminveden rajoitin väärin säädetty	- Sääda lämminveden rajoitin





Säkerhetsanvisningar

- △ Handskar ska bäras under monteringsarbetet så att man kan undvika kläm- och skärskador.
- △ Stora tryckskillnader mellan anslutningarna för varmt och kallt vatten måste utjämnas.

Monteringsanvisningar

- Det måste undersökas om produkten har transportskador innan den monteras. Efter monteringen accepteras inga transport- eller ytskiktsskador.
- Ledningarna och blandaren måste monteras, spolas igenom och kontrolleras enligt de gällande normerna.
- De installationsriktlinjer som gäller i länderna ska följas.
- **72805XXX, 72807XXX, 72827XXX:** Endast disk- och tvättmaskiner som är försedda med DVGW-märkning får anslutas till kopplingsventilen utan extra uppsäkring.
- **72843XXX, 72844XXX:** Blandaren kan inte användas tillsammans med en varmvattenberedare.

Tekniska data

Driftstryck:	max. 1 MPa
Rek. driftstryck:	0,1 - 0,5 MPa
Tryck vid provtryckning:	1,6 MPa (1 MPa = 10 bar = 147 PSI)
Varmvattentemperatur:	max. 60 °C
Termisk desinfektion:	70 °C / 4 min

Produkten är enbart avsedd för dricksvatten!

Symbolförklaring



Använd inte silikon som innehåller ättiksyra!



Justering (se sidan 38)

Ställa in varmvattenregleringen. Tillsammans med varmvattenberedare rekommenderas inte en varmvattenspär.



Måtten (se sidan 40)



Flödesschema (se sidan 40)



Reservdelar (se sidan 53)

XXX = Färgkodning

000 = Krom

670 = Matt Black

800 = Rostfri-Optik

Specialtillbehör (medföljer ej leveransen)



Adapter (G³/₈ / G¹/₂)

#93395000 (se sidan 51 / 52)



Rengöring (se sidan 46)



Hantering (se sidan 39)

Hansgrohe rekommenderar att den första halvlitern inte används som dricksvatten på morgonen eller efter längre perioder utan användning.



Testsigill (se sidan 56)

Störning

Orsak

Åtgärd

Blandare är trög	- Patron defekt, förkalkad	- Byt ut patron
Blandare droppar	- Patron defekt	- Byt ut patron
Vatten kommer ut vid monteringsstaget	- Anslutningsslangar inte helt inskruvade i grundkonstruktionen	- Drag fast anslutningsslangar för hand.
	- O-ring på anslutningsslang defekt	- Byt ut O-ring
Varmvattentemperaturen är för låg	- Varmvattenreglering felaktigt inställd	- Ställ in varmvattenreglering





Saugumo technikos nurodymai

- ⚠ Apsaugai nuo užspaudimo ir įsijpavimo montavimo metu mūvėkite pirštines.
- ⚠ Turi būti išlyginti šalto ir karšto slėgio nelygumai.

Montavimo instrukcija

- Prieš montuojant būtina patikrinti, ar gaminyje nebuvo pažeistas transportavimo metu. Sumontavus pretenzijos dėl transportavimo ir paviršiaus pažeidimų nepriimamos.
- Vamzdžiai ir sujungimai turi būti montuojami, plaunami ir tikrinami pagal galiojančias normas.
- Laikykitės atitinkamoje šalyje galiojančių direktyvų dėl įrengimo.
- **72805XXX, 72807XXX, 72827XXX:** Be papildomos apsaugos prie įrenginio jungiamojo vožtuvo junkite tik skalbimo arba indų plovimo mašinas, turinčias DVGW ženklą.
- **72843XXX, 72844XXX:** Armatūros negalima naudoti kartu su tekančio vandens šildytuvu.

Techniniai duomenys

Darbinis slėgis: ne daugiau kaip 1 MPa
 Rekomenduojamas slėgis: 0,1 - 0,5 MPa
 Bandomasis slėgis: 1,6 MPa
 (1 MPa = 10 barų = 147 PSI)

Karšto vandens temperatūra: ne daugiau kaip 60 °C
 Terminis dezinfekavimas: 70 °C / 4 min

Produktas skirtas tik geriamajam vandeniui!

Simbolio aprašymas



Nenaudokite silikono, kurio sudėtyje yra acto rūgšties!



Reguliavimas (žr. psl. 38)

Karšto vandens ribojimas. Kartu su cirkuliaciniais šildytuvais nerekomenduojama naudoti karšto vandens blokavimo įtaisų.



Išmatavimai (žr. psl. 40)



Pralaidumo diagrama (žr. psl. 40)



Atsarginės dalys (žr. psl. 53)

XXX = Spalvos
 000 = Chrom
 670 = Matt Black
 800 = Plienas

Specialūs priedai (nėra pridedama)



Adapteris (G^{3/8} / G^{1/2})
 #93395000 (žr. psl. 51 / 52)



Valymas (žr. psl. 46)



Eksplotacija (žr. psl. 39)

Naudojant po ilgesnės pertraukos, „Hansgrohe“ rekomenduoja pirmo pusės litro vandens nevartoti kaip geriamąją.



Bandymo pažyma (žr. psl. 56)

Gedimas	Priežastis	Priemonė
Sunkiai sukiojama rankenėlė	- Kasetė pažeista, užkalkėjusi	- Pakeisti kasetę
Maišytuvus praleidžia vandenį	- Kasetė pažeista	- Pakeisti kasetę
Prateka vanduo per tvirtinimo kotą	- Prijungimo žarnos nepilnai įsuktos į korpusą	- Prijungimo žarnas prisukti ranka
	- Pajungimo žarnos tarpinė pažeista	- tarpinę pakeisti
Per maža karšto vandens temperatūra	- Neteisingai nustatytas karšto vandens ribotuvus	- Nustatyti karšto vandens ribotuvą





Sigurnosne upute

- ⚠ Prilikom montaže se radi sprječavanja prignječenja i posjekotina moraju nositi rukavice.
- ⚠ Velika razlika u pritisku između vruće i hladne vode mora biti izbalansirana.

Upute za montažu

- Prije montaže mora se provjeriti je li proizvod oštećen prilikom transporta. Nakon ugradnje se ne priznaju nikakve reklamacije koje se odnose na površinska i transportna oštećenja.
- Cijevi i armatura moraju biti postavljeni, isprani i testirani prema važećim normama.
- Obvezno se moraju uvažiti propisi o instalacijama koji vrijede u dotičnoj zemlji.
- **72805XXX, 72807XXX, 72827XXX:** Samo perilice za suđe ili rublje sa oznakom DVGW smijete koristiti bez dodatnog osiguranja priključnog ventila!
- **72843XXX, 72844XXX:** Armatura se ne može rabiti u kombinaciji sa protočnim bojlerom.

Tehnički podatci

Najveći dopušteni tlak:	tlak 1 MPa
Preporučeni tlak:	0,1 - 0,5 MPa
Probni tlak:	1,6 MPa
	(1 MPa = 10 bar = 147 PSI)
Temperatura vruće vode:	tlak 60 °C
Termička dezinfekcija:	70 °C / 4 min
Proizvod je koncipiran isključivo za pitku vodu!	

Opis simbola



Nemojte koristiti silikon koji sadrži octenu kiselinu!



Regulacija (pogledaj stranicu 38)

Namještanje limitera tople vode. U kombinaciji s protočnim bojlerima nije preporučljiva primjena sustava za blokiranje dotoka tople vode.



Mjere (pogledaj stranicu 40)



Dijagram protoka

(pogledaj stranicu 40)



Rezervni djelovi

(pogledaj stranicu 53)

- XXX = Boje
- 000 = Krom
- 670 = Matt Black
- 800 = Plemeniti Čelik

Posebni pribor (Nije sadržano u isporuci!)



Prilagodnik (G^{3/8} / G^{1/2})
#93395000 (pogledaj stranicu 51 / 52)



Čišćenje (pogledaj stranicu 46)



Upotreba (pogledaj stranicu 39)

Hansgrohe preporuča da ujutro ili nakon duljeg nekorštenja prvih 1/2 litre vode ne upotrebljavate za piće.



Oznaka testiranja

(pogledaj stranicu 56)

Greška

Uzrok

Otklanjanje

Ručica se zaglavila	- Neispravan uložak Taloženje kamenca	- Zamijenite uložak
Slavina kaplje	- Neispravan uložak	- Zamijenite uložak
Voda izlazi na dijelu gdje je slavina učvršćena	- Priključna crijeva nisu potpuno učvršćena na tijelo - O-prsteni priključnih crijeva su neispravni	- Priključna crijeva učvrstite rukom - Zamijenite O-prsten
Preniska temperatura tople vode	- Limiter vruće vode nije dobro podešen	- Podesite limiter vruće vode





Güvenlik uyarıları

- ⚠ Montaj esnasında ezilme ve kesilme gibi yaralanmaları önlemek için eldiven kullanılmalıdır.
- ⚠ Sıcak ve soğuk su bağlantıları arasında büyük basınç farklılıkları varsa, bu basınç farklılıklarının dengelenmesi gerekir.

Montaj açıklamaları

- Montaj işleminden önce ürün nakliye hasarları yönünden kontrol edilmelidir. Montaj işleminden sonra nakliye veya yüzey hasarları için sorumluluk üstlenilmemektedir.
- Boruların ve armatürün montajı, yıkanması ve kontrolü geçerli normlara göre yapılmalıdır.
- Ülkelerde geçerli kurulum yönetmeliklerine riayet edilmelidir.
- **72805XXX, 72807XXX, 72827XXX:** Sadece DVGW işarefine sahip bulaşık ya da çamaşır makineleri ek emniyet olmadan cihaz bağlantı valfına bağlanmalıdır.
- **72843XXX, 72844XXX:** Armatür bir akış ısıtıcısı ile birlikte kullanılamaz.

Teknik bilgiler

İşletme basıncı:	azami 1 MPa
Tavsiye edilen işletme basıncı:	0,1 - 0,5 MPa
Kontrol basıncı:	1,6 MPa
	(1 MPa = 10 bar = 147 PSI)
Sıcak su sıcaklığı:	azami 60°C
Termik dezenfeksiyon:	70°C / 4 dak
Ürün sadece şebeke suyu için tasarlanmıştır!	

Simge açıklaması



Asetik asit içeren silikon kullanmayın!



Ayarlama (bakınız sayfa 38)

Sıcak su sınırlamasının ayarlanması. Sıcak su kilidinin sürekli ısıtıcıyla kullanılması tavsiye edilmez.



Ölçüleri (bakınız sayfa 40)



Akış diyagramı (bakınız sayfa 40)



Yedek Parçalar (bakınız sayfa 53)

XXX = Renkler
000 = Krom
670 = Matt Black
800 = Paslanmaz Çelik-Optik

Özel aksesuarlar

(Teslimat kapsamına dahil değildir)



Adaptör (G^{3/8} / G^{1/2})
#93395000 (bakınız sayfa 51 / 52)



Temizleme (bakınız sayfa 46)



Kullanımı (bakınız sayfa 39)

Hansgrohe sabahları uzun durgunluk süresi sonrasında ilk yarım litre suyun içme suyu olarak kullanılmamasını önerir.



Kontrol işareti (bakınız sayfa 56)

arıza	sebebi	yardım
Batarya kullanımı ağırlaşıyor	- Kartuş Bozulmuş ve kireçlenmiş olabilir	- Kartuşu değiştirin
Batarya su damlatıyor	- Kartuş bozuk olabilir	- Kartuşu değiştirin
Sabitlenme kutusundan su çıkışı	- Bağlantı hortumları ana gövdeye tamamen vidalanmamış	- Bağlantı hortumlarını elinizle sıkın
	- Bağlantı hortumundaki O-ring arızalı	- O-ringi değiştirin
Sıcak suyun derecesi çok düşük	- Isı limitleyici düzgün çalışmıyor	- Isı limitleyiciyi yeniden ayarlayın





Instrucțiuni de siguranță

- ⚠ La montare utilizați mănuși pentru evitarea contuziunilor și tăierii mâinilor.
- ⚠ Diferențele de presiune mari între alimentarea cu apă rece și apă caldă trebuie echilibrate.

Instrucțiuni de montare

- Înainte de instalare verificați, dacă produsul prezintă deteriorări de transport. După instalare garanția nu acoperă deteriorările de transport și cele de suprafață.
- Conductele și bateriile trebuie montate, spălate și verificate conform normelor în vigoare.
- Respectați reglementările referitoare la instalare valabile în țara respectivă.
- **72805XXX, 72807XXX, 72827XXX:** Conectați numai mașinile de spălat sau mașinile de spălat vase fără siguranță adițională la ventilul de conectare a aparatului, care sunt marcate cu simbolul DVGW.
- **72843XXX, 72844XXX:** Bateria nu poate fi utilizată în combinație cu un boiler în flux continuu.

Date tehnice

Presiune de funcționare: max. 1 MPa
 Presiune de funcționare recomandată: 0,1 - 0,5 MPa
 Presiune de verificare: 1,6 MPa
 (1 MPa = 10 bar = 147 PSI)

Temperatura apei calde: max. 60°C
 Dezinfecție termică: 70°C / 4 min

Produsul este destinat exclusiv pentru apă potabilă.

Descrierea simbolurilor



Nu utilizați silikon cu conținut de acid acetic!



Reglare (vezi pag. 38)

Reglarea limitatorului de apă caldă. Nu se recomandă folosirea unui limitator de apă caldă în combinație cu un boiler instant.



Dimensiuni (vezi pag. 40)



Diagrama de debit (vezi pag. 40)



Piese de schimb (vezi pag. 53)

XXX = Coduri de culori
 000 = Crom
 670 = Matt Black
 800 = Otel Inox

Accesorii opționale

(nu este inclus în setul livrat)



Adaptor (G^{3/8} / G^{1/2})
 #93395000 (vezi pag. 51 / 52)



Curățare (vezi pag. 46)



Utilizare (vezi pag. 39)

Hansgrohe vă recomandă, ca dimineața sau după perioade mai lungi de pauză să nu folosiți prima jumătate de litru de apă pentru băut.



Certificat de testare (vezi pag. 56)

Deranjament	Cauza	Măsurile de remediere
Bateria se mișcă dificil	- Cartuș defect din cauza depunerilor de calcar	- Schimbați cartușul.
Bateria picură	- Cartuș defect	- Schimbați cartușul.
Scurgere de apă la șaftul de fixare.	- Furtunurile de racordare nu sunt bine înșurubate în corpul bateriei.	- Strângeți cu mâna furtunurile de racordare.
	- Inelul O de la furtunul de racord defect	- Schimbați inelul O.
Temperatura apei calde este prea mică	- Limitarea temperaturii apei calde setată incorect.	- Setați limitarea temperaturii apei calde.





Υποδειξεις ασφαλείας

- △ Για να αποφύγετε τραυματισμούς κατά τη συναρμολόγηση πρέπει να φοράτε γάντια.
- △ Οι διαφορές της πίεσης μεταξύ της σύνδεσης κρύου και ζεστού νερού θα πρέπει να αντισταθμίζονται.

Οδηγίες συναρμολόγησης

- Πριν τη συναρμολόγηση πρέπει να εξεταστεί το προϊόν για ζημιές μεταφοράς. Μετά την εγκατάσταση δεν αναγνωρίζονται ζημιές από τη μεταφορά ή επιφανειακές ζημιές.
- Οι σωλήνες και η μπαταρία πρέπει να τοποθετηθούν σύμφωνα με τα ισχύοντα πρότυπα, να τεθούν υπό πίεση και να δοκιμαστούν.
- Θα πρέπει να τηρούνται οι οδηγίες εγκατάστασης που ισχύουν σε κάθε κράτος.
- **72805XXX, 72807XXX, 72827XXX:** Μόνο πλυντήρια πιάτων ή πλυντήρια ρούχων που φέρουν το σήμα DVGW επιτρέπεται να συνδεθούν στη βαλβίδα σύνδεσης της συσκευής χωρίς πρόσθετη ασφάλεια.
- **72843XXX, 72844XXX:** Η μπαταρία δεν μπορεί να χρησιμοποιηθεί σε συνδυασμό με ταχυθερμοσίφωνα.

Τεχνικά Χαρακτηριστικά

Λειτουργία πίεσης:	έως 1 MPa
Συνιστώμενη λειτουργία πίεσης:	0,1 - 0,5 MPa
Πίεση ελέγχου:	1,6 MPa (1 MPa = 10 bar = 147 PSI)
Θερμοκρασία ζεστού νερού:	έως 60 °C
Θερμική απολύμανση:	70 °C / 4 min

Το προϊόν έχει σχεδιαστεί αποκλειστικά για πόσιμο νερό!

Περιγραφή συμβόλων



Μην χρησιμοποιείτε σιλικόνη που περιέχει οξικό οξύ!



Ρύθμιση (βλ. Σελίδα 38)

Ρύθμιση του δοσομετρητή ζεστού νερού. Δεν συνιστάται η διάταξη φραγής ζεστού νερού σε συνδυασμό με ταχυθερμοσίφωνα.



Διαστάσεις (βλ. Σελίδα 40)



Διάγραμμα ροής (βλ. Σελίδα 40)



Ανταλλακτικά (βλ. Σελίδα 53)

XXX = Χρώματα
000 = Επιχρωμιωμένο
670 = Matt Black
800 = Οπική Ανοξειδωτου Χάλυβα

Ειδικά αξεσουάρ (δεν περιλαμβάνεται στον παραδοτέο εξοπλισμό)



Προσαρμογέας (G^{3/8} / G^{1/2})
#93395000 (βλ. Σελίδα 51 / 52)



Καθαρισμός (βλ. Σελίδα 46)



Χειρισμός (βλ. Σελίδα 39)

Η Hansgrohe συνιστά το πρωί ή μετά από μεγάλα χρονικά διαστήματα αχρσίας να μην χρησιμοποιείτε το πρώτο μισό λίτρο νερό σαν πόσιμο.



Σήμα ελέγχου (βλ. Σελίδα 56)

Βλάβη	Αιτία	Διόρθωση
Σκληρή μπαταρία (μείκτης)	- Ελαττωματικό φυσίγγιο, άλατα	- Αλλαγή φυσιγγίου
Η μπαταρία στάζει	- Ελαττωματικό φυσίγγιο	- Αλλαγή φυσιγγίου
Διαρροή νερού στον άξονα στερέωσης	- Οι σωλήνες σύνδεσης δεν είναι πλήρως βιδωμένοι στο βασικό κορμό - Ο στρογγυλός δακτύλιος στο σωλήνα σύνδεσης είναι ελαττωματικός	- Σφίξτε τους σωλήνες σύνδεσης με το χέρι - Αλλάξτε το στρογγυλό δακτύλιο
Χαμηλή θερμοκρασία ζεστού νερού	- Λάθος ρύθμιση της περιοριστικής διάταξης ζεστού νερού	- Ρυθμίστε την περιοριστική διάταξη του ζεστού νερού





Varnostna opozorila

- △ Pri montaži je treba nositi rokavice, da se prepreči poškodbe zaradi zmečkanja ali urezov.
- △ Velike razlike v tlaku med priključkom za mrzlo in priključkom za toplo vodo je potrebno izravnati.

Navodila za montažo

- Pred montažo je treba izdelek preveriti glede morebitnih transportnih poškodb. Po vgradnji transportne ali površinske poškodbe ne bodo več priznane.
- Cevi in armaturo je treba montirati, izprati in preveriti po veljavnih standardih.
- Upoštevati je treba pravilnike o inštalacijah, ki veljajo v posamezni državi.
- **72805XXX, 72807XXX, 72827XXX:** Na priključni ventil priprave se smejo brez dodatne zaščite priklopiti le pomivalni ali pralni stroji z znakom kakovosti DVGW.
- **72843XXX, 72844XXX:** Armature ni možno uporabiti v povezavi s pretočnim grelnikom.

Tehnični podatki

Delovni tlak: maks. 1 MPa
 Priporočeni delovni tlak: 0,1 - 0,5 MPa
 Preskusni tlak: 1,6 MPa
 (1 MPa = 10 bar = 147 PSI)

Temperatura tople vode: maks. 60°C
 Termična dezinfekcija: 70°C / 4 min

Proizvod je zasnovan izključno za sanitarno vodo!

Opis simbola



Ne smete uporabiti silikona, ki vsebuje osetno kislino!



Justiranje (glejte stran 38)

Nastavitev omejevalnika tople vode. V povezavi s pretočnimi grelniki uporaba zapore tople vode ni priporočljiva.



Mere (glejte stran 40)



Diagram pretoka (glejte stran 40)



Rezervni deli (glejte stran 53)

XXX = Barve
 000 = Krom
 670 = Matt Black
 800 = Videz Legiranega Jekla

Poseben pribor (Ni vključeno)



Adapter (G^{3/8} / G^{1/2})
 #93395000 (glejte stran 51 / 52)



Čiščenje (glejte stran 46)



Upravljanje (glejte stran 39)

Hansgrohe priporoča, da zjutraj ali po daljšem času stagnacije prvga pol litra vode ne uporabite kot pitno vodo.



Preskusni znak (glejte stran 56)

Napaka	Vzrok	Pomoč
Težko premikanje armature	- Pokvarjen vložek, poapneno	- Zamenjajte vložek
Iz armature kaplja	- Pokvarjen vložek	- Zamenjajte vložek
Uhajanje vode ob pritrdilnem nastavku	- Priključne cevi niso popolnoma privijačene v osnovno ogrodje	- Ročno zatisnite priključne cevi
	- Obročna tesnila priključnih gibkih cevi so pokvarjena	- Zamenjajte obročno tesnilo
Prenizka temperatura tople vode	- Omejevalnik tople vode ni pravilno nastavljen	- Nastavite omejevalnik tople vode



Ohutusjuhised

- △ Kandke paigaldamisel muljumis- ja löikevigastuste vältimiseks kindaid.
- △ Kui külma ja kuuma vee ühenduste surve on väga erinev, tuleb need tasakaalustada.

Paigaldamisjuhised

- Enne paigaldamist tuleb toodet kontrollida transpordikahjustuste osas. Pärast paigaldamist ei tunnustata enam transpordi- või pinnakahjustuste kaebuseid.
- Voolikute ja segisti paigaldamisel, loputamisel ja kontrollimisel tuleb lähtuda kehtivatest normatiividest.
- Vastavas riigis kehtivaid paigalduseeskirju tuleb järgida.
- **72805XXX, 72807XXX, 72827XXX:** Seadme ühendusklapiga võib ühendada ainult DVGW-tähistega nõudepesu- või pesumasina.
- **72843XXX, 72844XXX:** Segistit ei saa kasutada koos läbivoolu-veesoojendiga.

Tehnilised andmed

Töörõhk maks. 1 MPa
 Soovitav töörõhk: 0,1 - 0,5 MPa
 Kontrollsurve: 1,6 MPa
 (1 MPa = 10 baari = 147 PSI)
 Kuuma vee temperatuur: maks. 60°C
 Termiline desinfektsioon: 70°C / 4 min
 Toode on ette nähtud eranditult joogivee jaoks!

Sümbolite kirjeldus



Ärge kasutage äädikhapet sisaldavat silikooni!



Reguleerimine (vt lk 38)

Sooja vee piirangu seadistamine. Ühenduses boileritega ei ole sooja vee blokeeringu soovitatav.



Mõõtude (vt lk 40)



Läbivooludiagramm (vt lk 40)



Varuosad (vt lk 53)

XXX = Värvid
 000 = Kroom
 670 = Matt Black
 800 = Roostevaba Optik

Spetsiaalne lisavarustus (ei sisaldu komplektis)



Adapter (G^{3/8} / G^{1/2})
 #93395000 (vt lk 51 / 52)



Puhastamine (vt lk 46)



Kasutamine (vt lk 39)

Hansgrohe soovib mitte kasutada esimest poolt liitrit hommikuti või pärast pikemat seisakuaega joogiveena.



Kontrollsertifikaat (vt lk 56)

Rike	Põhjus	Lahendus
Segisti käib raskelt	- Tööelement on katkine, lubjastunud	- Vahetage tööelement
Segisti tilgub	- Tööelement on katkine	- Vahetage tööelement
Veeleke kinnituse juures	- Ühendusvoolikud ei ole korralikult põhikorpuse külge kruvitud	- Kruvige ühendusvoolikud käega kinni
	- Ühendusvoolikute O-rõngastihendid katki	- Vahetage O-rõngastihend
Sooja vee temperatuur liiga madal	- Kuuma vee piirang valesti seatud	- Seadke kuuma vee piirang



Drošības norādes

- △ Montāžas laikā, lai izvairītos no saspiedumiem un iegriezumiem, nepieciešams nēsāt cimdus.
- △ Jāizlīdzina spiediena atšķirības starp aukstā un karstā ūdens pievadiem.

Norādījumi montāžai

- Pirms montāžas nepieciešams pārbaudīt, vai produktam transportēšanas laikā nav radušies bojājumi. Pēc iebūvēšanas bojājumi, kas radušies transportēšanas laikā, vai virsmas bojājumi netiek atzīti.
- Caurulvadi un armatūra ir jāuzstāda, jāizskalo un jāpārbauda saskaņā ar spēkā esošajiem standartiem.
- Jāievēro attiecīgās valstīs spēkā esošās montāžas prasības.
- **72805XXX, 72807XXX, 72827XXX:** Ierīču pieslēgšanas vārstam drīkst pieslēgt bez papildus nodrošinājuma tikai tās trauku mazgājamās mašīnas un veļas mašīnas, kurām ir DVGW-zīme.
- **72843XXX, 72844XXX:** Armatūru nevar izmantot kopā ar caurplūdes sildītāju.

Tehniskie dati

Darba spiediens:	maks. 1 MPa
Ieteicamais darba spiediens:	0,1 - 0,5 MPa
Pārbaudes spiediens:	1,6 MPa
	(1 MPa = 10 bar = 147 PSI)
Karstā ūdens temperatūra:	maks. 60 °C
Termiskā dezinfekcija :	70 °C / 4 min

Izstrādājums ir paredzēts tikai dzeramajam ūdenim!

Simbolu nozīme



Neizmantojiet silikonu, kas satur etiķskābi!



Ieregulēšana (skat. lpp. 38)

Karstā ūdens ierobežotāja regulēšana. Kopā ar caurteces sildītājiem nav ieteicams izmantot ūdens bloķētāju.



Izmērus (skat. lpp. 40)



Caurplūdes diagramma

(skat. lpp. 40)



Rezerves daļas (skat. lpp. 53)

XXX = Krāsu kodi
000 = Hroma
670 = Matt Black
800 = Tērauda

Speciāli aksesuāri

(komplektā netiek piegādāts)



Adapteris (G^{3/8} / G^{1/2})
#93395000 (skat. lpp. 51 / 52)



Tīrīšana (skat. lpp. 46)



Lietošana (skat. lpp. 39)

Hansgrohe iesaka no rīta vai pēc ilgākiem pārtraukumiem nelietot pirmo puslitru ūdens dzeršanai.



Pārbaudes zīme (skat. lpp. 56)

Traucējums	Iemesls	Bojājumu novēršana
Jaucējkrāns smagi grozāms	- Bojāta kartuša, aizkalķojusies	- Nomainīt kartušu
Jaucējkrāns pil	- Bojāta kartuša	- Nomainīt kartušu
Ūdens noplūde pie nostiprinājuma	- Pieslēguma šļūtenes nav līdz galam ieskrūvētas pamatelementā	- Pieslēguma šļūtenes ar roku pievilkt stingrāk
	- Bojāti pieslēguma šļūtenju O-gredzeni	- Nomainīt O-gredzenu
Pārāk zema ūdens temperatūra	- Nepareizi noregulāta karstā ūdens bloķēšana	- Noregulēt karstā ūdens ierobežošanu





Sigurnosne napomene

- △ Prilikom montaže se radi sprečavanja prignječenja i posekotina moraju nositi rukavice.
- △ Velika razlika u pritisku između vruće i hladne vode mora biti izbalansirana.

Instrukcije za montažu

- Pre montaže se mora proveriti da li je proizvod oštećen pri transportu. Nakon ugradnje se ne priznaju nikakve reklamacije koje se odnose na površinska i transportna oštećenja.
- Vodovi i armatura moraju biti postavljeni, isprani i testirani prema važećim normama.
- Treba se pridržavati propisa koji u određenim zemljama važe za instalacije.
- **72805XXX, 72807XXX, 72827XXX:** Samo mašine za veš ili suđe s oznakom DVGW se smeju priključivati bez dodatnog osiguranja priključnog ventila.
- **72843XXX, 72844XXX:** Armatura se ne može upotrebljavati u kombinaciji sa protočnim bojlerom.

Tehnički podaci

Radni pritisak:	maks. 1 MPa
Preporučeni radni pritisak:	0,1 - 0,5 MPa
Probni pritisak:	1,6 MPa (1 MPa = 10 bar = 147 PSI)
Temperatura vruće vode:	maks. 60°C
Termička dezinfekcija:	70°C / 4 min

Proizvod je koncipiran isključivo za pijaću vodu!

Opis simbola



Nemojte koristiti silikon koji sadrži sircetnu kiselinu!



Podešavanje (vidi stranu 38)

Podešavanje ograničivača tople vode. U kombinaciji sa protočnim bojlerima ne preporučuje se primena sistema za blokiranje dotoka tople vode.



Mere (vidi stranu 40)



Dijagram protoka (vidi stranu 40)



Rezervni delovi (vidi stranu 53)

XXX = Oznake boja
 000 = Hrom
 670 = Matt Black
 800 = Dezen Plemeniti Čelik

Poseban pribor (Nije sadržano u isporuci)



Adapter (G^{3/8} / G^{1/2})
 #93395000 (vidi stranu 51 / 52)



Čišćenje (vidi stranu 46)



Rukovanje (vidi stranu 39)

Hansgrohe preporučuje da ujutru ili nakon dužeg nekorisćenja prvih pola litre vode ne koristite za piće.



Ispitni znak (vidi stranu 56)

Smetnja	Uzrok	Pomoć
Ručica se zaglavila	- Neispravna kartuša, nataloženi kamenac	- Zamenite kartušu
Slavina kaplje	- Neispravna kartuša	- Zamenite kartušu
Voda izlazi na delu gde je slavina učvršćena	- Priključna creva nisu potpuno učvršćena na telo - O prstenovi priključnih creva su neispravni	- Priključna creva učvrstite rukom - Zamenite O prsten
Preniska temperatura tople vode	- Ograničavač vruće vode nije dobro podešen	- Podesite ograničavač vruće vode



Sikkerhetshenvisninger

- △ Bruk hansker under montasjen for å unngå klem- og kuttskader.
- △ Store trykkdifferanser mellom kaldt- og varmtvannstilkoblinger skal utlignes.

Montagehenviisninger

- Før montasjen skal produktet sjekkes for transportskader. Etter monteringen aksepteres ikke noen transport- eller overflateskader.
- Ledningene og armaturen skal monteres, spyles og sjekkes iht. de gyldige normer.
- Gjeldende retningslinjer for rørleggerarbeid i de enkelte land skal følges.
- **72805XXX, 72807XXX, 72827XXX:** Kun oppvask- eller vaskemaskiner med DVGW merke kan kobles uten tilleggssikring til ventilen for aparatetilkoblingen.
- **72843XXX, 72844XXX:** Armaturen kan ikke brukes i forbindelse med en gjennomstrømningsvarmer.

Tekniske data

Driftstrykk	maks. 1 MPa
Anbefalt driftstrykk:	0,1 - 0,5 MPa
Prøvetrykk	1,6 MPa
	(1 MPa = 10 bar = 147 PSI)
Varmtvannstemperatur	maks. 60°C
Termisk desinfisering:	70°C / 4 min

Produktet er utelukkende designet for drikkevann!

Symbolbeskrivelse



Ikke bruk silikon som inneholder eddiksyre!



Justering (se side 38)

Innstilling av varmtvannsbegrensning. I forbindelse med gjennomstrømningsvarmere er det ikke anbefalt å bruke en varmtvannspærre.



Mål (se side 40)



Gjennomstrømningsdiagram (se side 40)



Serviceledler (se side 53)

XXX = Fargekode
 000 = Krom
 670 = Matt Black
 800 = Rustfritt Stål Optikk

Ekstratilbehør (ikke med i leveransen)



Adapter (G^{3/8} / G^{1/2})
 #93395000 (se side 51 / 52)



Rengjøring (se side 46)



Betjening (se side 39)

Om morgen og etter lengre stagnasjonstider anbefaler Hansgrohe å ikke bruke den første halvliteren som drikkevann.



Prøveemerke (se side 56)

Feil	Årsak	Feilrettelse
Armatyr ikke lett bevegelig	- Kartusj defekt, forkalkning	- Kartusj byttes
Armatyr drypper	- Kartusj defekt	- Kartusj byttes
Vannlekkasje på festeskapt	- Tilkoblingslanger ikke skrudd helt inn i basiselement	- Tilkoblingslanger trekkes fast fra hånd
	- O-ring på tilkoblingslanger defekt	- O-ring byttes
For lav varmtvannstemperatur	- Varmtvannsbegrensning er feil innstilt	- Varmtvannsbegrensning innstilles



Указания за безопасност

- ⚠ При монтажа трябва да се носят ръкавици, за да се избегнат наранявания поради притискане или порязване.
- ⚠ Големите разлики в налягането между изводите за студената и топлата вода трябва да се изравняват.

Указания за монтаж

- Преди монтажа продуктът трябва да се провери за транспортни щети. След монтажа не се признават транспортни или повърхностни щети.
- Тръбопроводите и арматурата трябва да се монтира, промият и проверят в съответствие с валидните норми.
- Трябва да бъдат спазвани валидните в съответните страни предписания за инсталиране.
- **72805XXX, 72807XXX, 72827XXX:** Само миялни или перални машини, които притежават знак DVGW, могат да бъдат свързвани към свързващия клапан без допълнителни приспособления.
- **72843XXX, 72844XXX:** Арматурата не може да се използва във връзка с проточен нагревател.

Технически данни

Работно налягане: макс. 1 МПа
 Препоръчително работно налягане: 0,1 - 0,5 МПа
 Контролно налягане: 1,6 МПа
 (1 МПа = 10 bar = 147 PSI)
 Температура на горещата вода: макс. 60 °C
 Термична дезинфекция: 70 °C / 4 мин
 Продуктът е разработен само за питейна вода!

Описание на символите



Не използвайте силикон, съдържащ оцетна киселина!



Юстиране (вижте стр. 38)

Настройка на ограничителя за топлата вода. Във връзка с проточни нагреватели не се препоръчва блокировка за топлата вода



Размери (вижте стр. 40)



Диаграма на потока (вижте стр. 40)



Сервизни части (вижте стр. 53)

XXX = Цветово кодиране
 000 = Хром
 670 = Matt Black
 800 = Оптика На Благородна Стомана

Специални принадлежности

(не се съдържа в обема на доставка)



Адаптер (G³/₈ / G¹/₂)
 #93395000 (вижте стр. 51 / 52)



Почистване (вижте стр. 46)



Обслужване (вижте стр. 39)

Hansgrohe препоръчва, сутрин и след по-продължително спиране първият половин литър да не се използва като питейна вода.



Контролен знак (вижте стр. 56)

Неизправност	Причина	Помощ
Трудно подвижна арматура	- Дефектна гилза, покрита с варовик	- Сменете гилзата
Арматурата капе	- Дефектна гилза	- Сменете гилзата
Избиване на вода от закрепващата шийка	- Свързващите маркучи не са напълно завинтени в основното тяло	- Затегнете на ръка свързващите маркучи
	- Дефектен О-образен пръстен на свързващия маркуч	- Смяна на О-образен пръстен
Твърде ниска температура на водата	- Ограничението за топлата вода е грушно настроено	- Настройте ограничението за топлата вода



Udhëzime sigurie

- △ Për të evituar lëndimet e pickimeve ose të prerjeve gjatë procesit të montimit duhet që të vishni doreza.
- △ Ndryshimet e mëdha të presionit mes lidhjeve të ujit të ftohtë dhe atij të ngrohtë duhen ekuilibruar.

Udhëzime për montimin

- Përpara montimit duhet që produkti të kontrollohet për dëmtime nga transporti. Pas instalimit nuk do të njihet asnjë dëmtim nga transporti ose dëmtim i sipërfaqes.
- Tubacionet dhe rubinetet duhet që të montohen, të shpëlahen dhe të kontrollohen sipas standardeve në fuqi
- Duhet të respektohen linjat udhëzuese të instalimit, të vlefshme për vendet respektive.
- **72805XXX, 72807XXX, 72827XXX:** Vetëm makinat larëse të enëve ose rrobave që përmbajnë shenjë e DVGW mund të lidhen me ventilin e lidhjes së pajisjes pa sigurim të posaçëm.
- **72843XXX, 72844XXX:** Armatura nuk mund të përdoret në kombinim me një ngrohës elektrik të ujit.

Të dhëna teknike

Presioni gjatë punës	maks. 1 MPa
Presioni i rekomanduar:	0,1 - 0,5 MPa
Presioni për provë:	1,6 MPa
	(1 MPa = 10 bar = 147 PSI)
Temperatura e ujit të ngrohtë	maks. 60 °C
Dezinfektim Termik:	70 °C / 4 min
Produkti është projektuar ekskluzivisht për ujë të pijshëm!	

Përshkrimi i simbolit



Mos përdorni silikon që në përbërje ka acid acetik.



Justimi (shih faqen 38)

Rregullimi i kufizimit me ujë të nxehtë. Nje kombinim me një bojler ujit nuk është i rekomanduar.



Përmasat (shih faqen 40)



Diagrami i qarkullimit (shih faqen 40)



Pjesët e servisit (shih faqen 53)

XXX = Kodimi me anë të ngjyrave
000 = Krom
670 = Matt Black
800 = Optikë Çeliku

Pajisje të posaçme

(nuk përfshihet në vëllimin e furnizimit)



Përshtatësi (G^{3/8} / G^{1/2})
#93395000 (shih faqen 51 / 52)



Pastrimi (shih faqen 46)



Përdorimi (shih faqen 39)

Hansgrohe rekomandon që në mëngjes ose pas periudhave të gjata që gjysmë litri i parë mos të pihet



Shenja e kontrollit (shih faqen 56)

Dëmtim

Shkaku

Ndihme

Armatura punon rende	- Kartusha me defekt, me kalk	- Kembeni kartushen
Armatura pikon	- Kartusha me defekt	- Kembeni kartushen
Dalje e ujit ne cilindrin fiksues	- Tubat e lidhjes jo komplet te vidhosur ne karkasen baze	- Shtrengojini manualisht tubat e lidhur
	- Unaza O tek tubi lidhes me defekt	- Kembeni unazen O
Temperaturë e ulët e ujit të ngrohtë	- Kufiri i ujit te ngrohte eshte regjistruar gabim	- Regjistroni kufirin e ujit te ngrohte



الضبط (راجع صفحة 38)

ضبط تحديد المياه الدافئة. لا ينصح باستخدام محدد المياه الدافئة مع سخان المياه الوتقي.

أبعاد (راجع صفحة 40)

رسم للصرف (راجع صفحة 40)

قطع الغيار (راجع صفحة 53)

الألوان = XXX
كروم = 000
Matt Black = 670
مظهر الإستنليس ستيل = 800

ملحقات خاصة
(غير مدرج مع المحتويات المسلمة)

محول (G $\frac{3}{8}$ / G $\frac{1}{2}$)
#93395000 (راجع صفحة 51 / 52)

التنظيف (راجع صفحة 46)

التشغيل (راجع صفحة 39)

تتصح شركة هانزجروهي Hansgrohe بعدم استخدام أول نصف لتر من الماء لغرض الشرب وذلك في الصباح أو بعد توقف استخدام الماء لفترات طويلة نسبياً.

شهادة اختبار (راجع صفحة 56)

تنبيهات الأمان

- ⚠ يجب ارتداء قفازات لليد أثناء التركيب لتجنب حدوث أخطار الإنحشار أو الجروح.
- ⚠ يجب أن يكون تيار الماء الساخن والماء البارد متعادلين في الضغط.

تعليمات التركيب

- قبل القيام بعملية التركيب، يجب فحص المنتج للتأكد من خلوه من أية تلفيات ناتجة عن النقل. بعد القيام بعملية التركيب، لن يتم الاعتراف بوجود أية تلفيات سطحية أو تلفيات ناتجة عن عملية النقل.
- يجب تركيب وغسيل واختبار التوصيلات وخلطات المياه طبقاً للمعايير السارية.
- يجب مراعاة القواعد الخاصة بالتركيب وأعمال السباكة وفقاً للوائح الخاصة بكل بلد.
- **72805XXX, 72807XXX, 72827XXX**: يمكن فقط توصيل غسالات الأطباق وغسالات الملابس التي تحمل علامة DVGW بصمام التوصيل بالأجهزة وبدون تأمين إضافي.
- **72843XXX, 72844XXX**: لا يمكن استخدام خلط الماء مع جهاز تسخين الماء الفوري.

المواصفات الفنية

ضغط التشغيل:
ضغط التشغيل الموصى به: 0,5 - 0,1 ميجاباسكال
ضغط الاختبار: 1,6 ميجاباسكال
(1 ميجاباسكال = 10 بار = 147 PSI)
درجة حرارة الماء الساخن:
تقديم حراري: الحد الأقصى 60°C
المنتج مخصص فقط لماء الشرب!
70°C / 4 الدقيقة

وصف الرمز

هام! لا تستخدم السليكون الذي يحتوي على أحماض!

العطل	السبب	العلاج والإصلاح
الخلاط ثقيل الحركة	- الخرطوشة تالفة، تراكم عليها الجير	- قم بتغيير الخرطوشة
تساقط قطرات مياه من الخلاط	- الخرطوشة تالفة	- قم بتغيير الخرطوشة
خروج الماء من جزء التثبيت	- خرطوم التوصيل ليست مربوطة في الجزء الرئيسي بشكل كامل	- اربط خرطوم التوصيل بيدك
	- الحلقة الدائرية الخاصة بخرطوم التوصيل تالفة	- قم بتغيير الحلقة الدائرية
درجة حرارة الماء الساخن منخفضة للغاية	- محدد الماء الساخن مضبوط بشكل خاطيء	- قم بضبط محدد الماء الساخن



Biztonsági utasítások

- △ A szerelésnél a zúzódások és vágási sérülések elkerülése érdekében kesztyűt kell viselni.
- △ A hidegvíz- és a melegvíz-csatlakozások közötti nagy nyomáskülönbséget kikell egyenlíteni!

Szerelési utasítások

- A szerelés előtt ellenőrizni kell, hogy a terméknek nincs-e szállítási sérülése. Beépítés után a szállítási- vagy felületi sérüléseket nem ismerik el.
- A vezetékeket és a csaptelepet az érvényes szabványoknak megfelelően kell felszerelni, öblíteni és ellenőrizni
- Az egyes országokban érvényes installációs irányelveket be kell tartani.
- **72805XXX, 72807XXX, 72827XXX:** Csak a DVGW-jelzéssel ellátott mosogató- vagy mosógépeket szabad kiegészítő biztosítás nélkül a készülék csatlakozószelvéhez csatlakoztatni.
- **72843XXX, 72844XXX:** A vízcsapot nem lehet átfolyós vízmelegítővel használni.

Műszaki adatok

Üzemi nyomás:	max. 1 MPa
Ajánlott üzemi nyomás:	0,1 - 0,5 MPa
Nyomáspróba:	1,6 MPa
	(1 MPa = 10 bar = 147 PSI)
Forróvíz hőmérséklet:	max. 60 °C
Termikus fertőtlenítés:	70 °C / 4 perc

A terméket kizárólag ivóvízhez tervezték!

Szimbólumok leírása



Ne használjon ecetsavtartalmú szilikon!



Beállítás (lásd az oldalon 38)

A meleg víz korlátozás beállítása. Átfolyós vízmelegítőknél meleg víz korlátozó használata nem ajánlott.



Méretet (lásd az oldalon 40)



Átfolyási diagramm

(lásd az oldalon 40)



Tartozékok (lásd az oldalon 53)

XXX = Színkódolás
 000 = Króm
 670 = Matt Black
 800 = Acéloptika

Egyéb tartozék

(a szállítási egység nem tartalmazza)



Adapter (G^{3/8} / G^{1/2})
 #93395000 (lásd az oldalon 51 / 52)



Tisztítás (lásd az oldalon 46)



Használat (lásd az oldalon 39)

- A csaptelepeken átfolyt víz hőmérséklete fogyasztásra szánt víz esetében a 65 °C-ot nem haladhatja meg. A csaptelep nem eredményezheti az emberi fogyasztásra (pl. ivás és főzés céljából) szánt víz minőségromlását.
- Beüzemelés és üzemszünetek után szigorúan be kell tartani a használati útmutatóban leírtakat. Beüzemeléskor a csaptelepet át kell öblíteni, legalább 2 percig történő hideg- és melegvízes folyamatot javasolunk. Minimum 1 napos üzemszünet után fogyasztás előtt a csaptelepben stagnáló hideg- illetve melegvíz fogyasztása nem javasolt, a csaptelepben stagnáló vizet ki kell engedni, legalább 2 perces folyamatot javasolt. A kifolytatás során nyert vizet ivóvízként, illetve ételkészítési céllal felhasználni nem szabad.
- Tekintettel arra, hogy a forró víz fémoldó képessége a hideg víznél nagyobb, emiatt főzés ivás céljából az OKI a hideg víz használatát javasolja.
- A csaptelepek perlátorát javasolt havonta vízkőteleníteni, illetve fertőtleníteni. A csaptelepek tisztítása, fertőtlenítése során kizárólag olyan vegyszer alkalmazható, amely megfelel a 201/2001. (X.25) Kormányrendelet, illetve a 38/2003. (VII.7) ÉSZCsM-FVM-KvVM együttes rendeletben leírtaknak.
- A perlátor működési elvéből adódóan jelentős aeroszolt képez, így Legionella expozíció szempontjából fokozott kockázatot jelent. Ezért alkalmazása nem javasolt az egészségügyi intézmények fekvőbeteg ellátó szobáiban, illetve minden olyan helyen, ahol a hideg és / vagy használati melegvíz Legionella csíraszám eléri a 49/2015 (XI.6.) EMMI rendelet alapján meghatározott beavatkozási szintet.



Vizsgajel (lásd az oldalon 56)



Hiba	Ok	Megoldás
Nehezen nyitható a csap.	- A kerámiabetét meghibásodott, elvízkövesedett.	- A kerámiabetétet ki kell cserélni.
Csöpög a csap.	- A kerámiabetét meghibásodott.	- A kerámiabetétet ki kell cserélni.
Vízkilépés a rögzítőrúdon	- A csatlakozótömlők nincsenek teljesen becsavarozva az akaptestbe	- A csatlakozótömlőket kézzel meghúzni
	- Csatlakozótömlő tömítőgyűrűje meghibásodott	- Tömítőgyűrű kicserélése
túl alacsony melegvíz hőmérséklet	- A melegvíz szabályozó rosszul van beállítva.	- A melegvíz szabályozót újra be kell állítani.



安全上の注意

- △ 施工の際は手を挟んだり怪我をしないように、手袋をはめてください。
- △ 給水・湯の圧力差は0.1(MPa)以内としてください。

施工上の注意

- 製品の施工前に輸送でのダメージがないか確認してください。施工後のキズ等のお申し出はお断りさせて頂いています。
- 配管と水栓は、関連法規に従って施工、洗浄、および試験を行ってください。
- 施工行う地域に適用される関連法規をお守りください。
- **72805XXX, 72807XXX, 72827XXX:** DVGWマークが付いた食洗機または洗濯機のみ、逆流防止装置などを追加しないで止水栓に接続できます(日本では関連法規に従ってください)。
- **72843XXX, 72844XXX:** 水栓は瞬間湯沸かし器での利用はできません。

技術資料

使用圧力: 最大 1 MPa
 推奨使用水圧: 0,1 - 0,5 MPa
 耐圧試験圧力: 1,6 MPa
 (1 MPa = 10 bar = 147 PSI)

給湯温度: 最大 60°C
 お湯による高温消毒: 70°C / 4分

この製品は飲料水での使用が前提となっています(日本においては水道法に適合する飲料水)!

アイコンの説明



酢酸系シリコンをご使用にならないでください!



調整 (次のページを参照 38)

お湯の流量制限の設定方法。瞬間湯沸かし器をご利用の際はお湯の流量制限はしないでください。



寸法 (次のページを参照 40)



流量曲線図 (次のページを参照 40)



スペアパーツ

(次のページを参照 53)

XXX = 仕上げ色

000 = Chrome

670 = Matt Black

800 = Stainless Steel Optic

スペシャルパーツ (別手配部品)



アダプタ (G $\frac{3}{8}$ / G $\frac{1}{2}$)

#93395000 (次のページを参照 51 / 52)



お手入れ方法

(次のページを参照 46)



使用方法 (次のページを参照 39)

ハンズグローエは、朝または長い間使用されなかった後に吐水する最初の0.5リットルは飲料水として使用しないことをお勧めします。



認証について

(次のページを参照 56)

症状	原因	対応策
水栓の開閉が重い	- カルキによるカートリッジ不具合	- カートリッジを交換してください
水栓の水漏れ	- カートリッジの不良	- カートリッジを交換してください
固定ネジ部分から水が漏れる	- 接続ホースが本体に完全にねじ込まれていない	- 接続ホースを手で増し締めしてください
	- 接続ホースのOリングの不具合	- Oリングを交換してください
吐水温度が低すぎる	- 温度リミッターの設定が正しくない	- 温度リミッターを設定してください

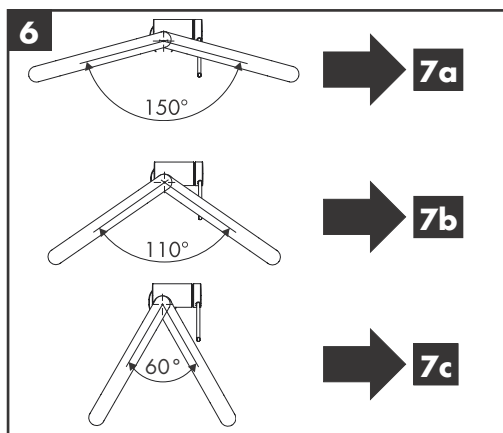
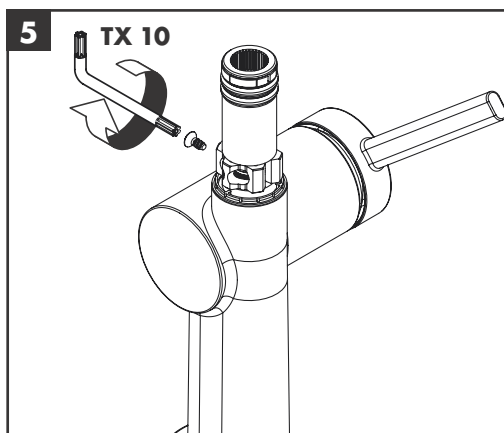
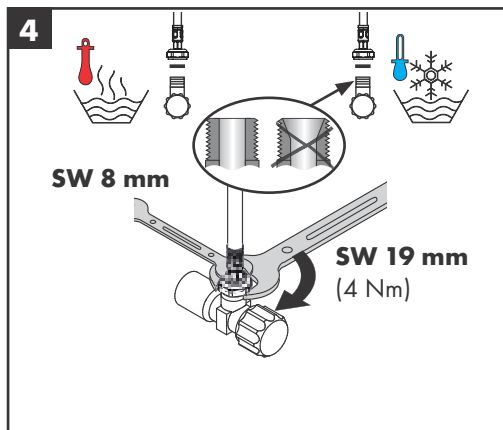
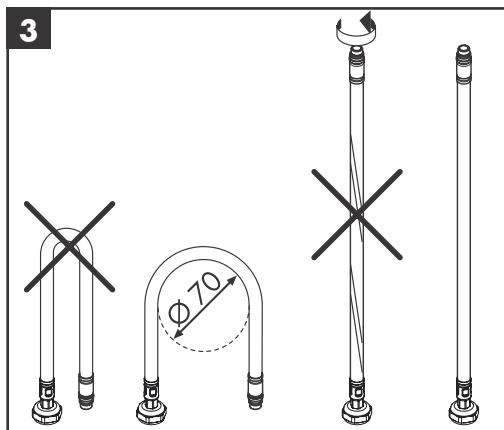
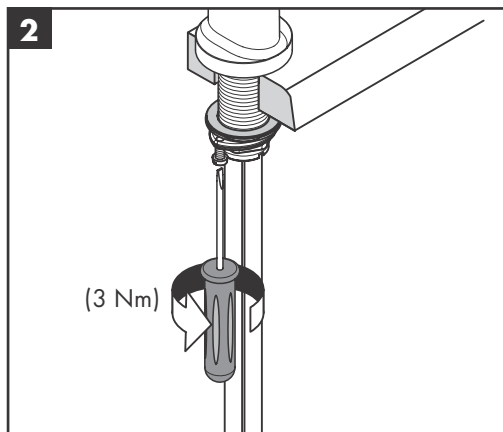
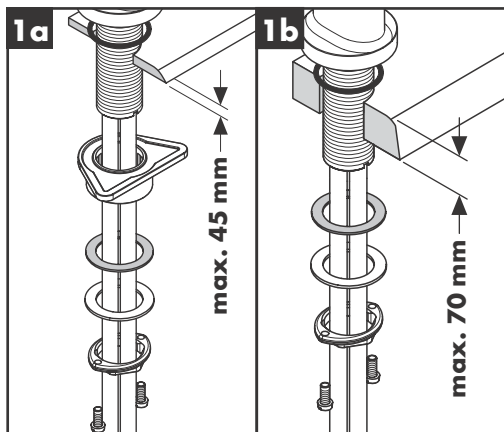



7a

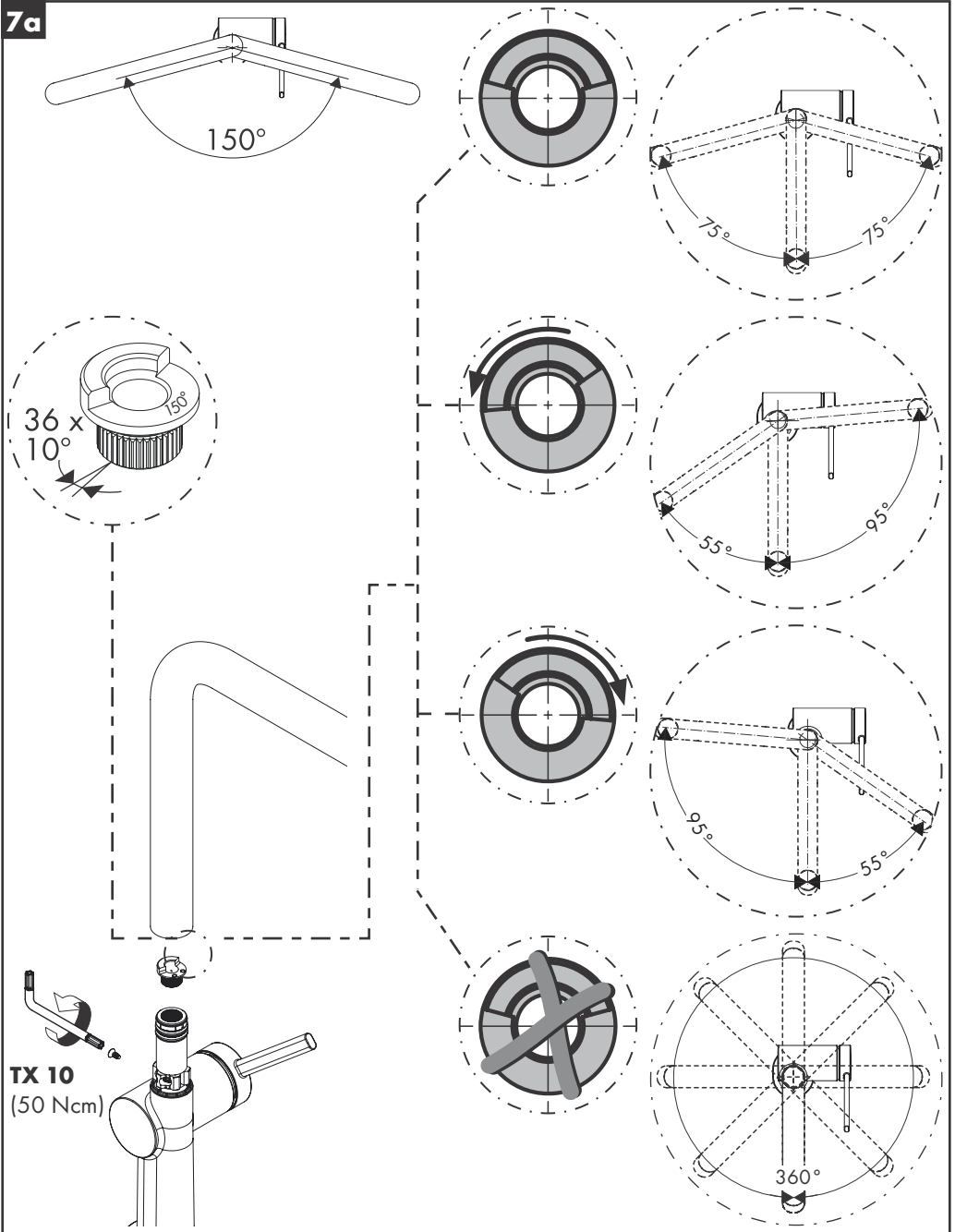



7b

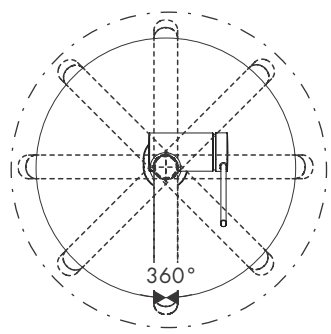
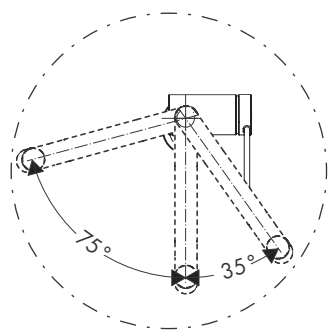
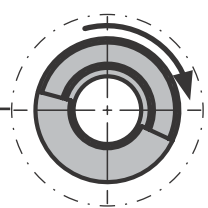
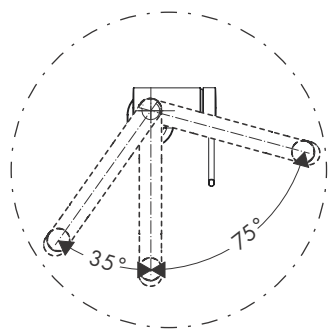
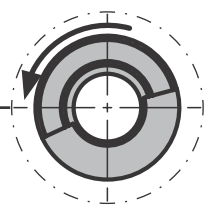
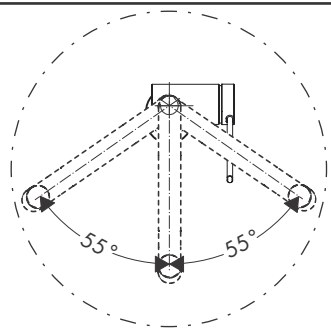
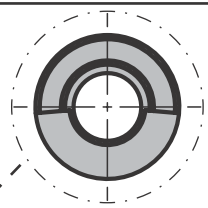
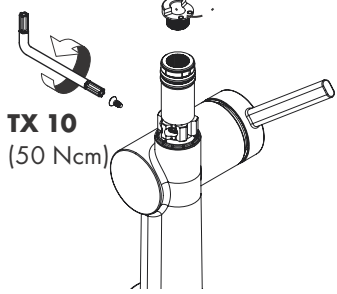
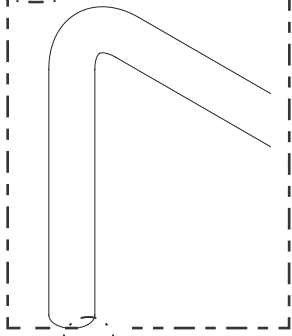
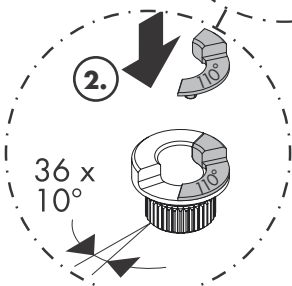
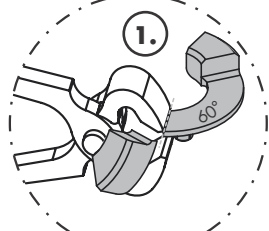
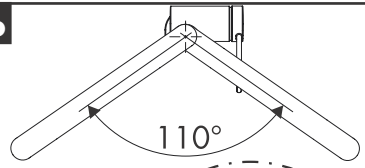



7c

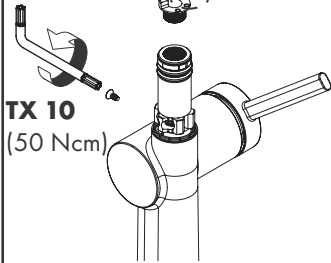
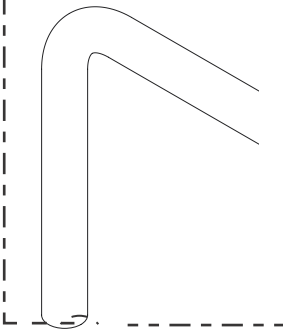
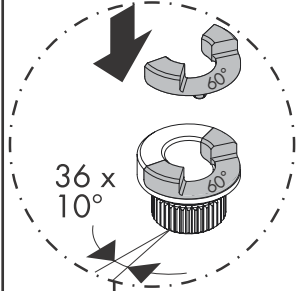
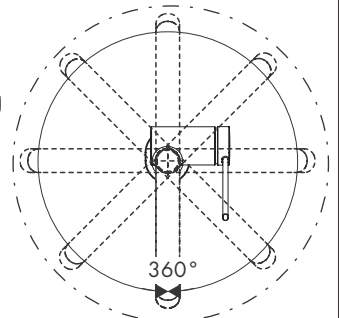
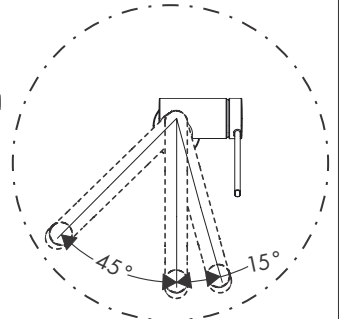
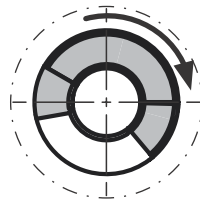
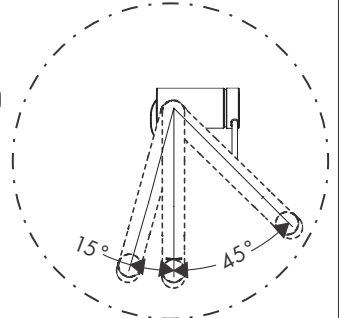
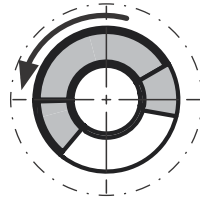
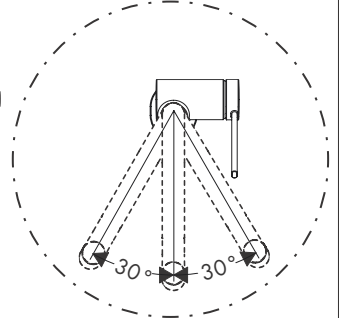
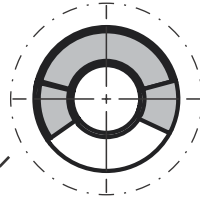
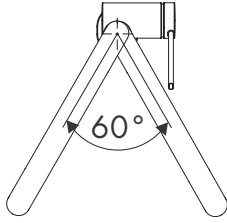

TX 10
(50 Ncm)

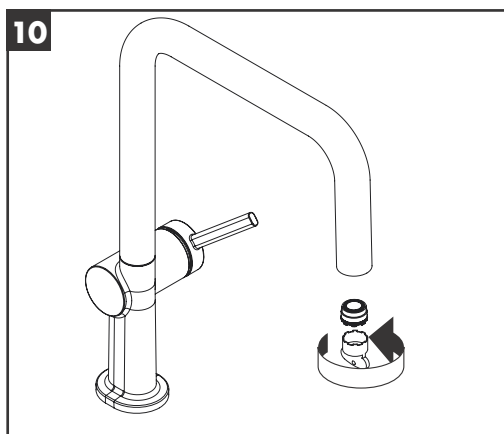
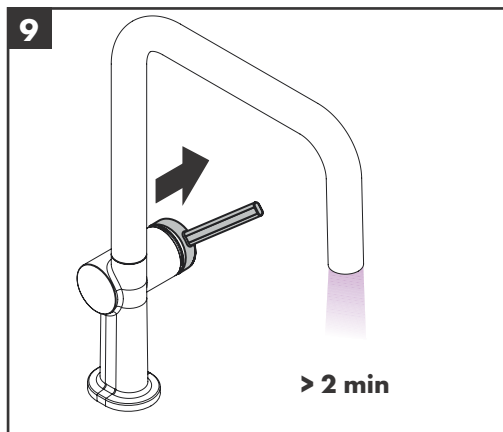
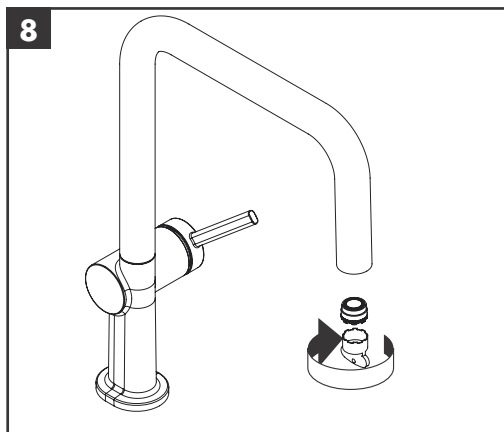

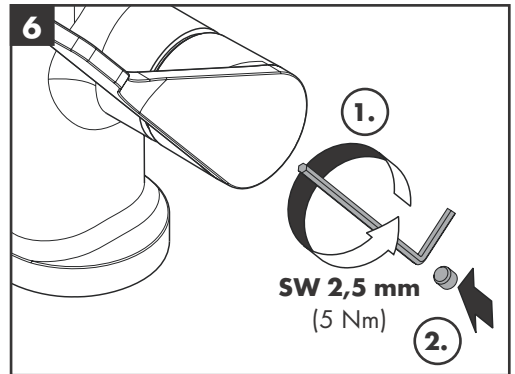
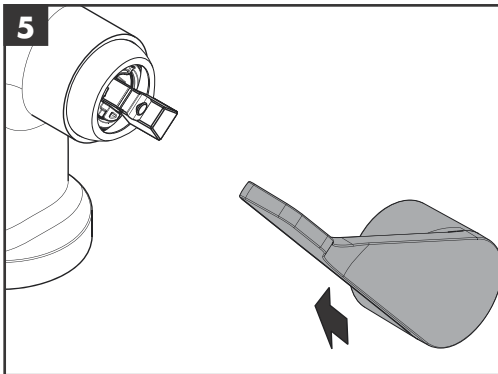
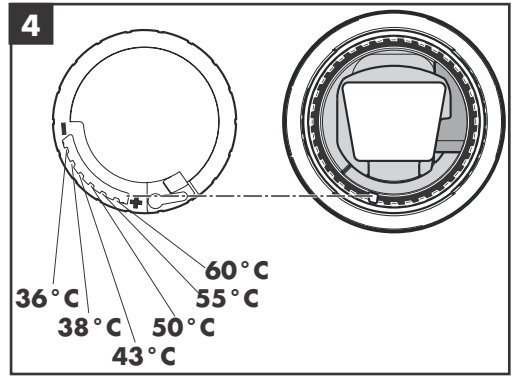
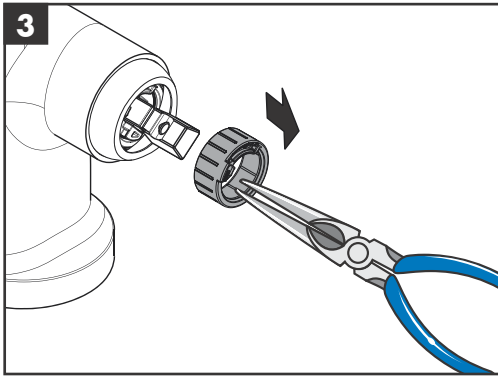
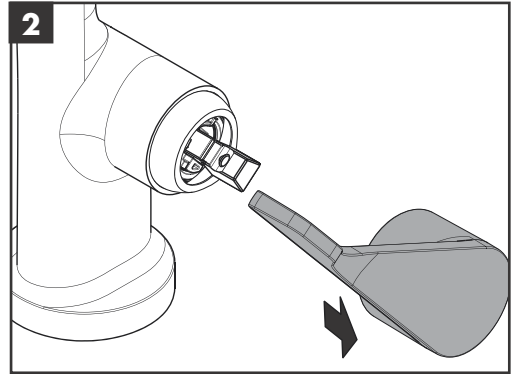
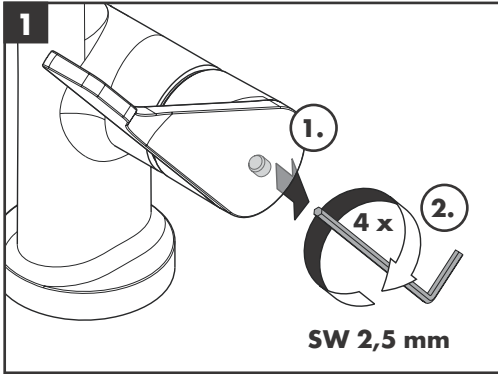

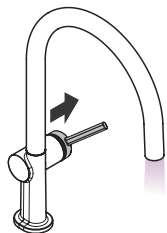

öffnen / ouvert / open / aperto / abierto / open /
 åbne / abrir / otworzyć / otevřít / otvorit / 开 /
 открыть / nyitás / avaaminen / öppna / atidaryti /
 Otvaranje / açmak / deschide / ανοικτό / odpreti /
 avage / atvērt / otvoriti / åpne / отварање / hare /
 فتح / 開く

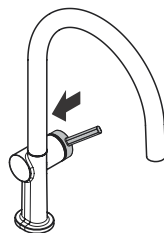

schließen / fermé / close / chiudere / cerrar / sluiten /
 lukke / fechar / zamknąć / zavřít / uzavrieť / 关 /
 закрыть / bezárás / sulkeminen / stänga / uždaryti /
 Zatvaranje / kapatmak / închide / κλειστό / zapreti /
 sulgege / aizvērt / zatvori / lukke / затварање /
 mbylle / إغلاق / 閉じる

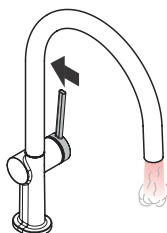

warm / chaud / hot / caldo / caliente / warm / varmt /
 quente / ciepła / teplá / teplá / 热 / горячая / meleg /
 lämmin / varmt / karštas / Vruća voda / sıcak / cald /
 ζεστό / toplo / kuum / karsts / topla / varm / тепло /
 i ngrohtë / ساخن / 温かい

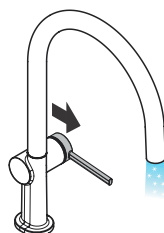

kalt / froid / cold / freddo / frío / koud / koldt / fria /
 zimna / studená / studená / 冷 / холодная / hideg /
 kylmä / kallt / šaltas / Hladno / soğuk / reze / κρύο /
 mrzlo / külm / auksts / hladno / kaldt / студено /
 i ftohtë / بارد / 冷たい

Talis M54 220 1jet
72805XXX

Talis M54 220 1jet
72807XXX

Talis M54 270 1jet
72827XXX

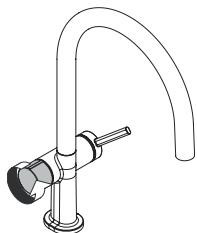

öffnen / ouvert / open /
 aperto / abierto / open /
 åbne / abrir / otworzyć /
 otevřít / otvorit / 开 /
 открыть / nyitás / avaaminen /
 öppna / atidaryti / Otvaranje /
 açmak / deschide / ανοικτό /
 odpreti / avage / atvērt /
 otvoriti / åpne / отварање /
 hare / فتح / 開く

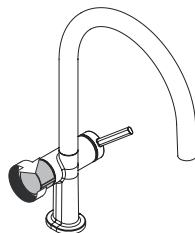

schließen / fermé / close /
 chiudere / cerrar / sluiten /
 lukke / fechar / zamknąć /
 zavřít / uzavrieť / 关 /
 закрыть / bezárás /
 sulkeminen / stänga / uždaryti /
 Zatvaranje / kapatmak /
 închide / κλειστό / zapreti /
 sulgege / aizvērt / zatvori /
 lukke / затварање /
 mbylle / إغلاق / 閉じる



Talis M54 U 220 1jet

72806XXX

Talis M54 U 220 Eco 1jet

72844XXX

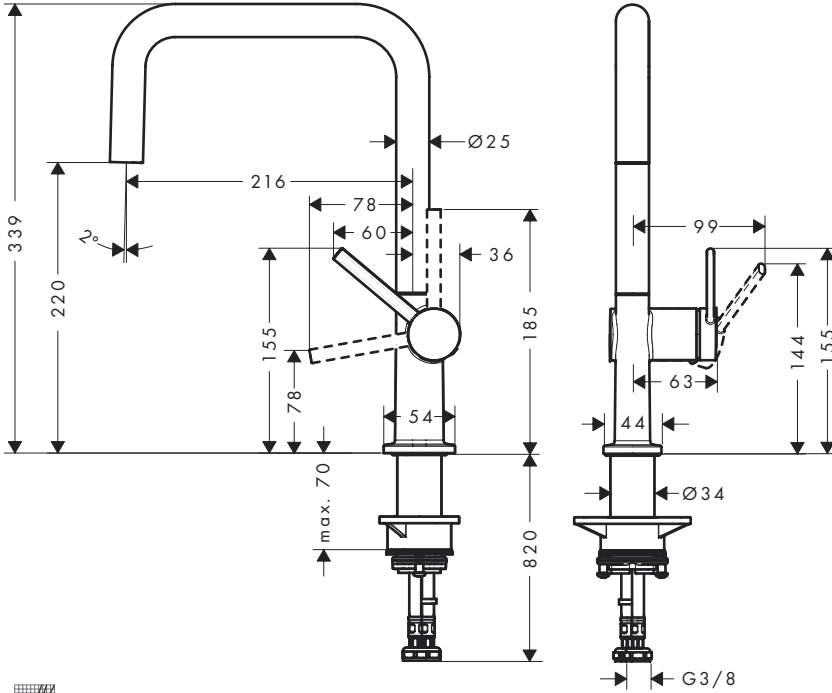

Talis M54 U 220 1jet

72806XXX

Talis M54 U 220 Eco 1jet

72844XXX

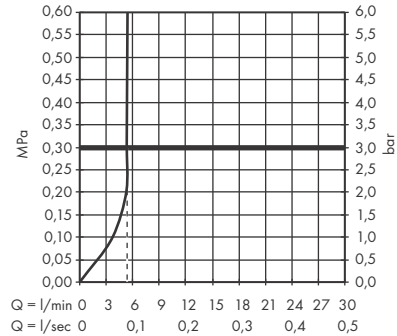
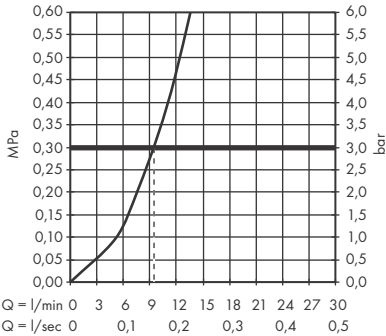



Talis M54 220 1jet

72804XXX

Talis M54 220 Eco 1jet

72843XXX

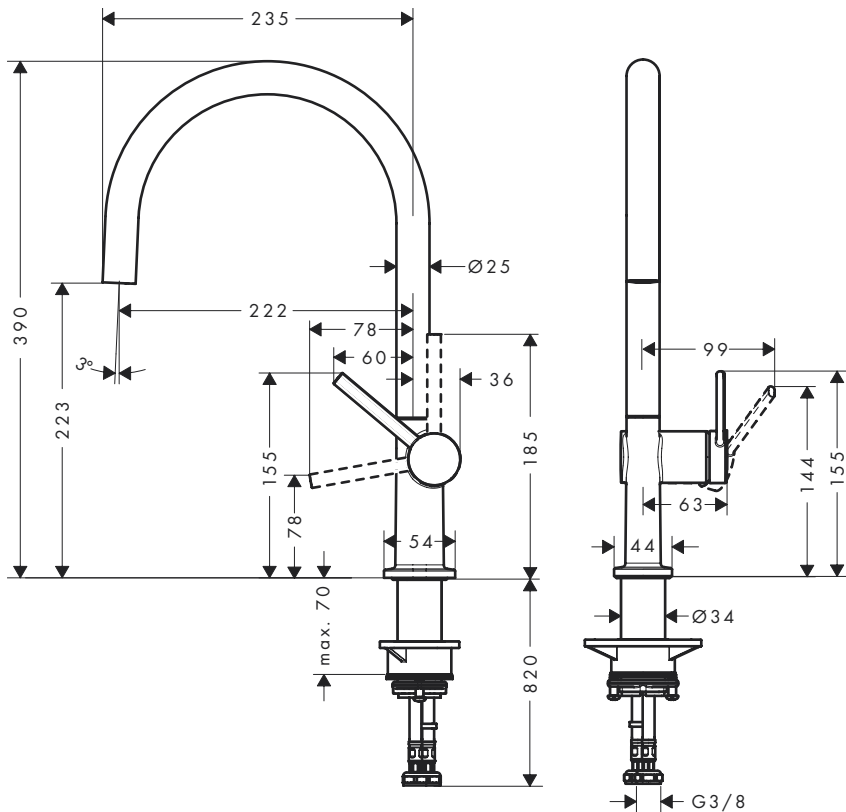

Talis M54 220 1jet

72804XXX

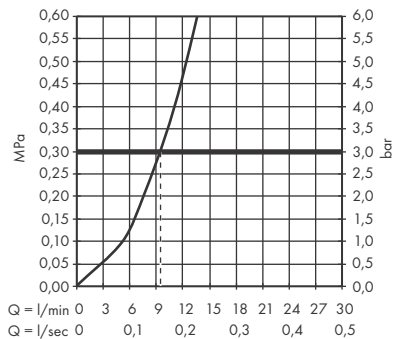

Talis M54 220 Eco 1jet

72843XXX

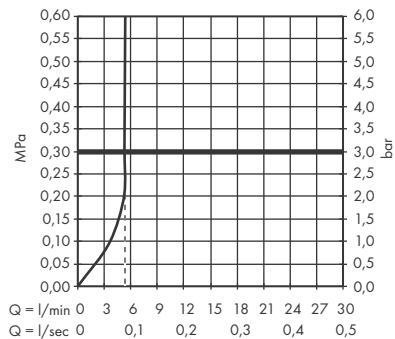



Talis M54 270 1jet

72840XXX

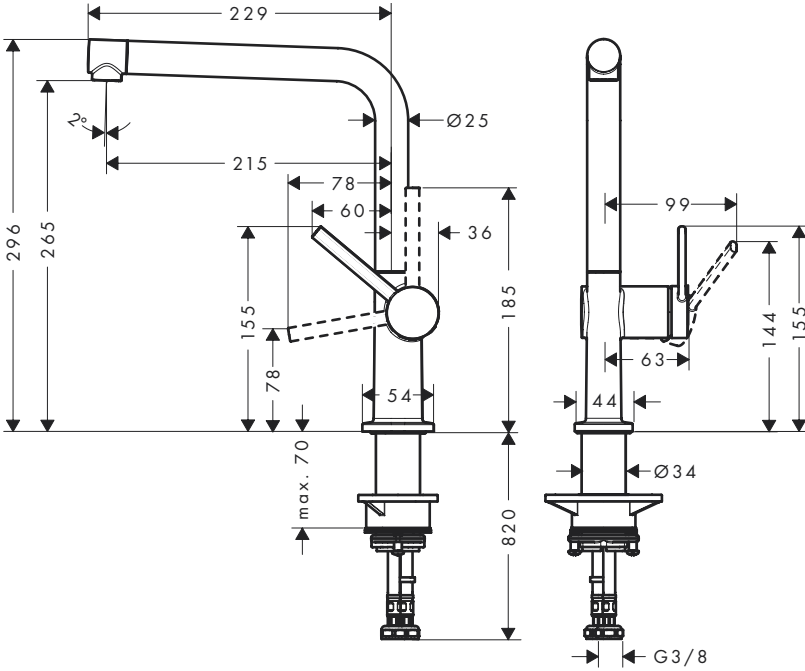

Talis M54 270 1jet

72840XXX

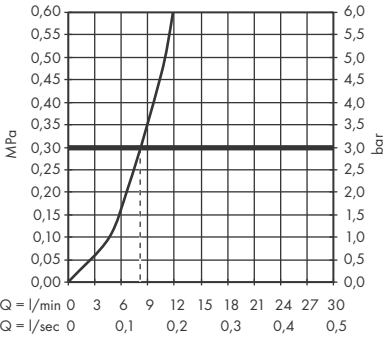



Talis M54 220 1jet

72805XXX

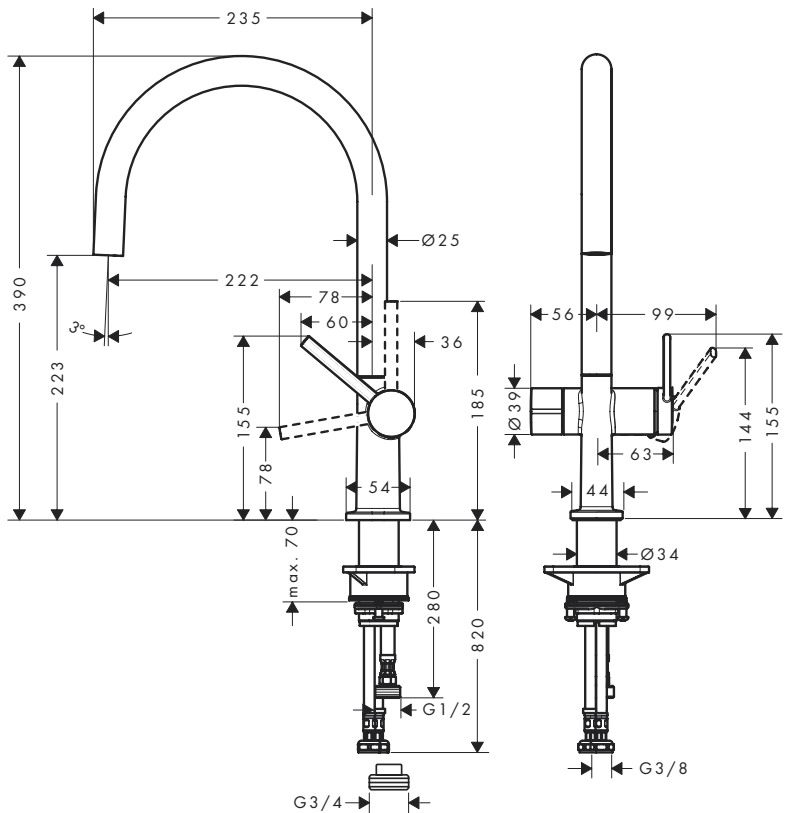

Talis M54 220 1jet

72805XXX

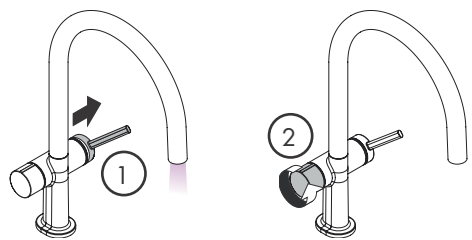
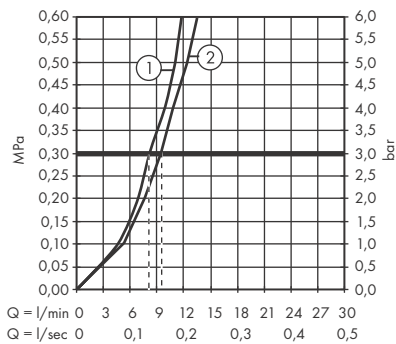



Talis M54 220 1jet

72807XXX

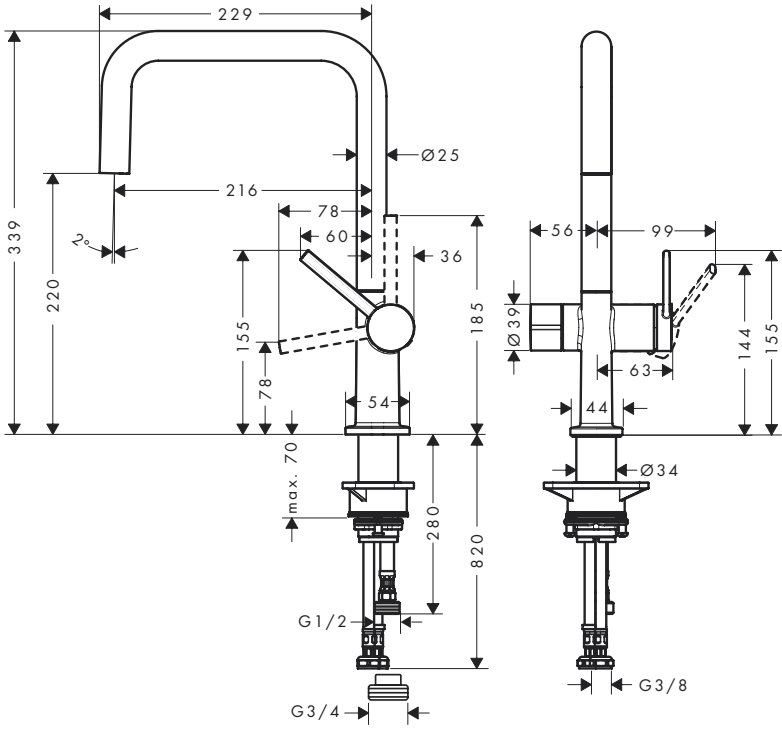

Talis M54 220 1jet

72807XXX

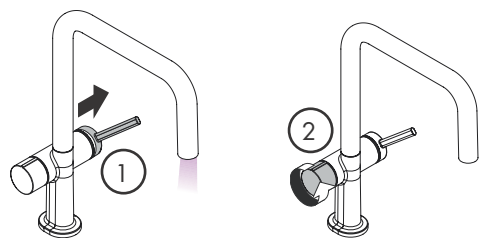
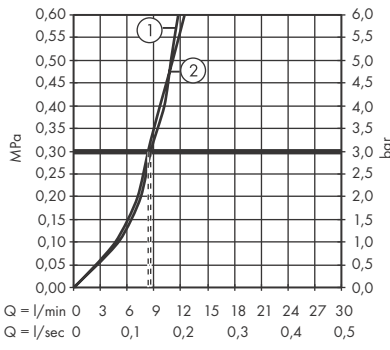



- DE** Reinigungsempfehlung / Garantie / Kontakt
- FR** Recommandation pour le nettoyage / Garanties / Contact
- EN** Cleaning recommendation / Warranty / Contact
- IT** Raccomandazione di pulizia / Garanzia / Contatto
- ES** Recomendaciones para la limpieza / Garantía / Contacto
- NL** Aanbevelingen inzake reiniging / Garantie / Contact
- DK** Rengøringsvejledning / Garanti / Kontakt
- PT** Recomendações de limpeza / Garantia / Contacto
- PL** Zalecenie dotyczące pielęgnacji / Gwarancja / Kontakt
- CS** Doporučení k čištění / Záruka / Kontakt
- SK** Odporúčania pre čistenie / Záruka / Kontakt
- ZH** 清洁指南 / 担保 / 接触
- RU** Рекомендации по очистке / Гарантия / Контакты
- FI** Puhdistussuositus / Takuu / Kosketus
- SV** Rengöringsrekommendationer / Garanti / Contacto
- LT** Valymo rekomendacijos / Garantija / Kontaktai
- HR** Preporuke za čišćenje / Garancija / Kontakt
- TR** Temizleme önerisi / Garanti / Temas
- RO** Recomandări pentru curățare / Garanție / Contact
- EL** Σύσταση καθαρισμού / Εγγύηση / επαφή
- SL** Priporočilo za čiščenje / Garancija / Kontakt
- ET** Puhastussooitused / Garantii / Kontakt
- LV** Tīrīšanas ieteikumi / Garantija / Kontakti
- SR** Preporuke za čišćenje / Garancija / Kontakt
- NO** Anbefaling for rengjøring / Garanti / Kontakt
- BG** Препоръка за почистване / Гаранция / Контакт
- SQ** Këshilla rreth pastrimit / Garancia / Kontakt
- KO** 세정시 권장사항 / 품질보증 / 접촉
- AR** توصيات التنظيف / الضمان (الولايات المتحدة الأمريكية) / اتصال
- HU** Tisztítási tanácsok / Garancia / érintkezés
- JP** お手入れの方法 / 保証について / ご連絡先



[www.hansgrohe.com/
cleaning-recommendation](http://www.hansgrohe.com/cleaning-recommendation)

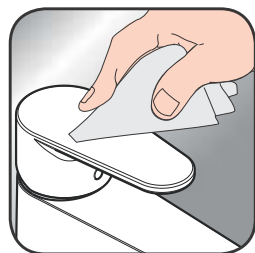

[www.hansgrohe.com/
cleaning-recommendation](http://www.hansgrohe.com/cleaning-recommendation)



[www.hansgrohe.com/
cleaning-recommendation](http://www.hansgrohe.com/cleaning-recommendation)



[www.hansgrohe.com/
cleaning-recommendation](http://www.hansgrohe.com/cleaning-recommendation)

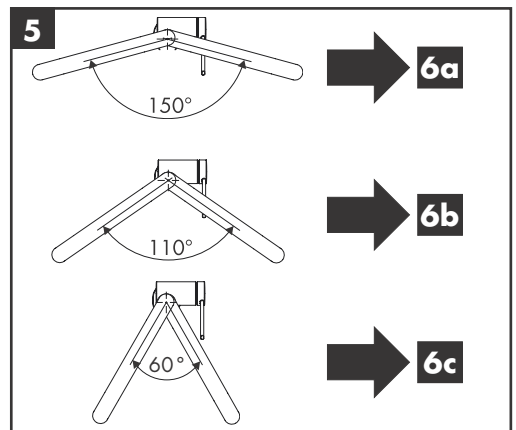
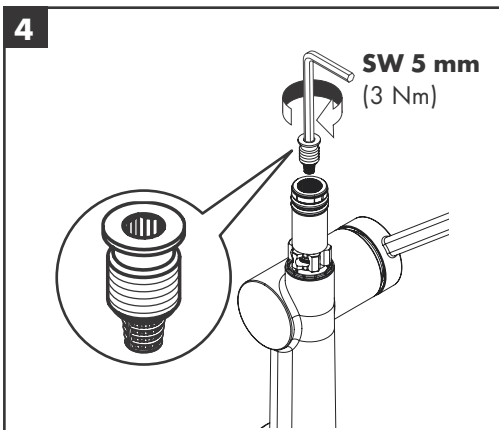
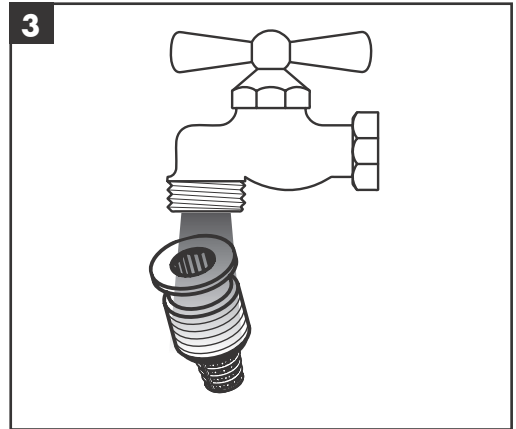
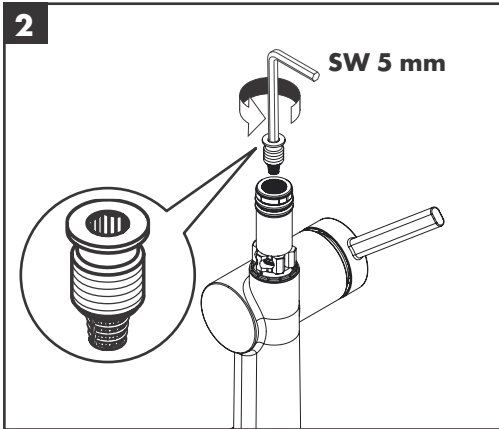
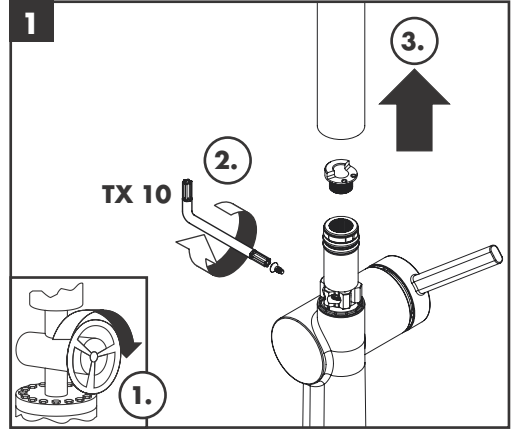
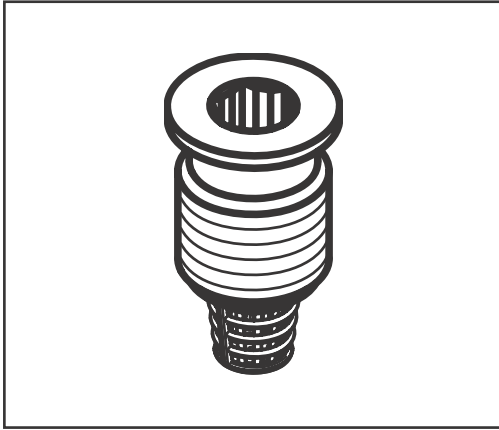



6a

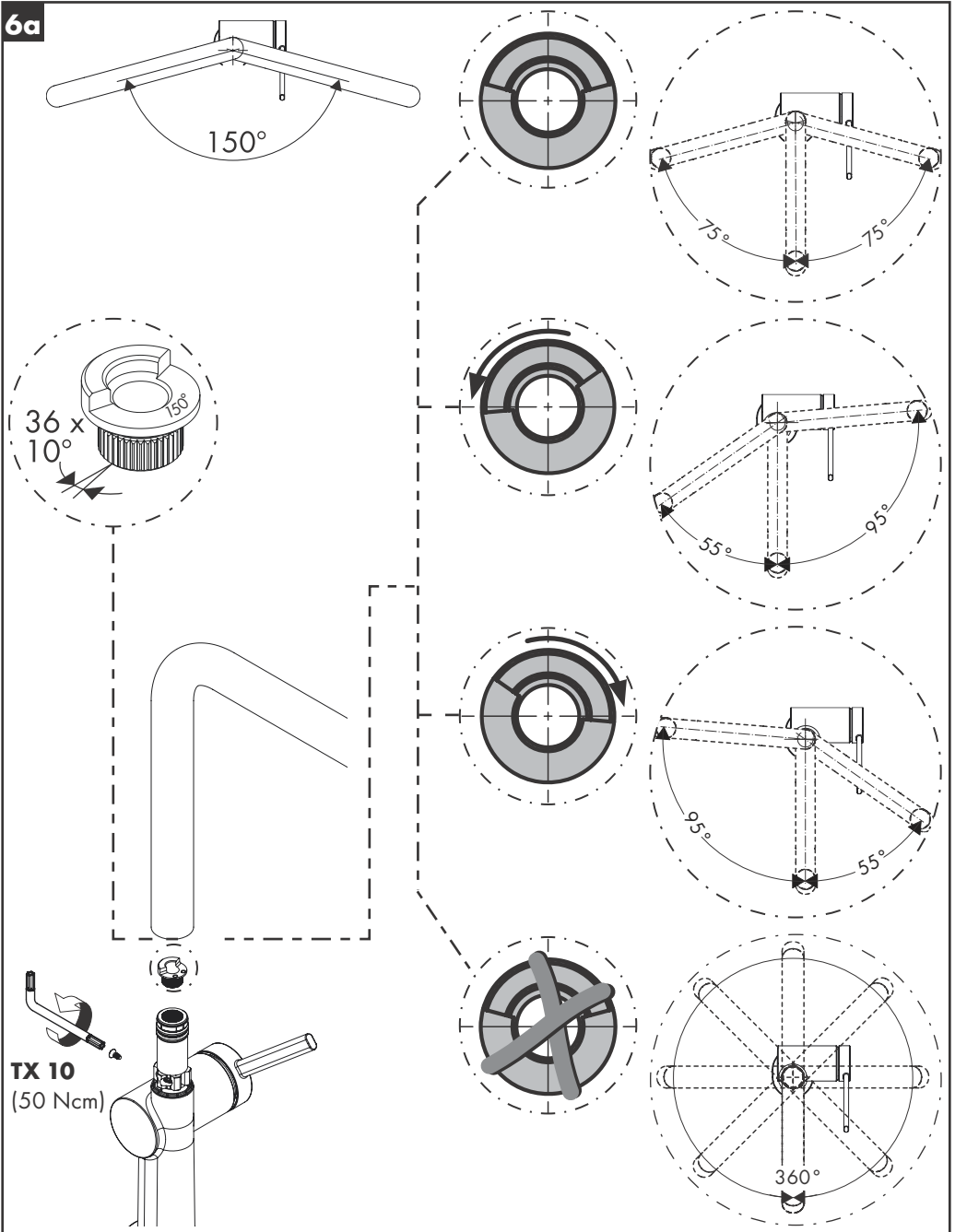



6b

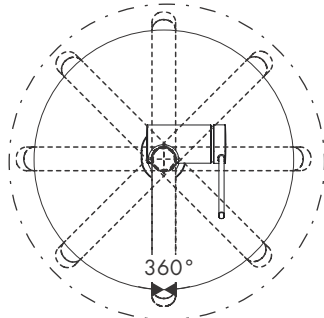
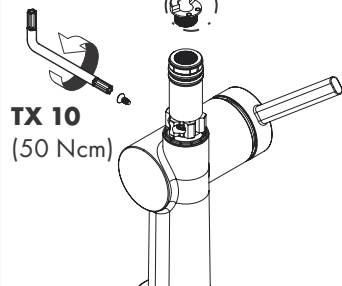
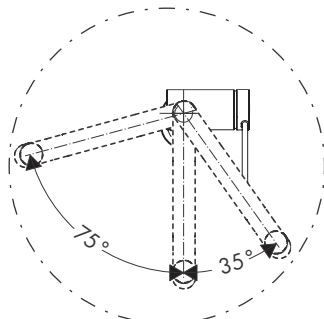
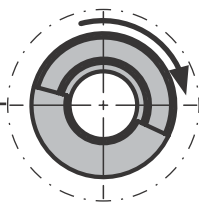
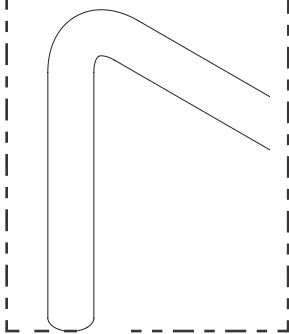
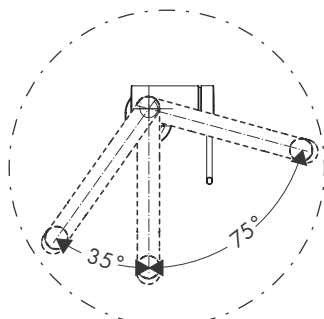
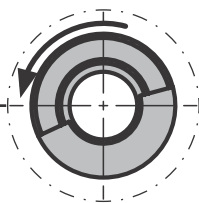
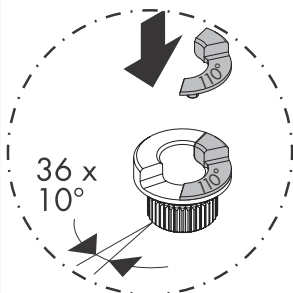
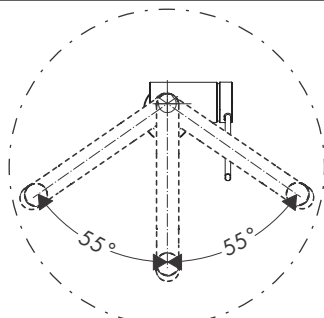
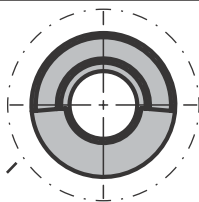
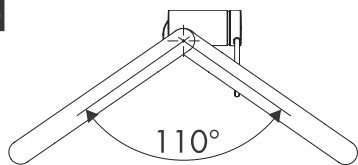



6c

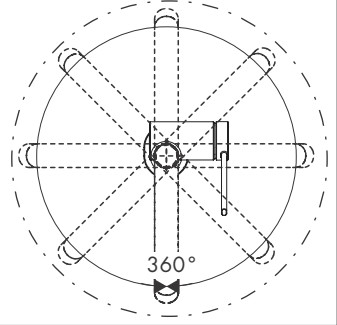
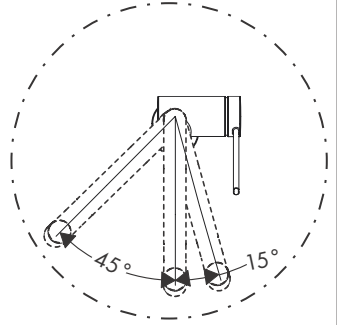
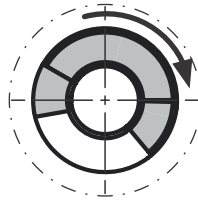
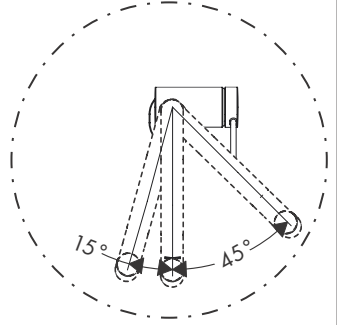
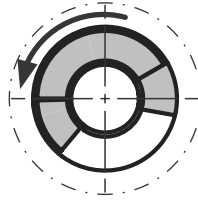
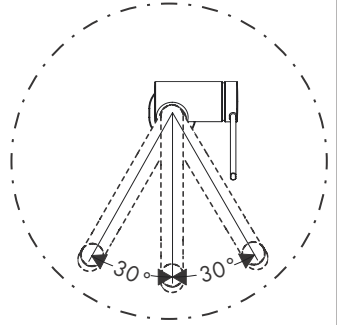
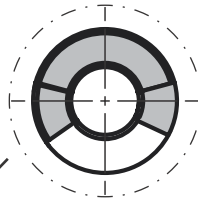
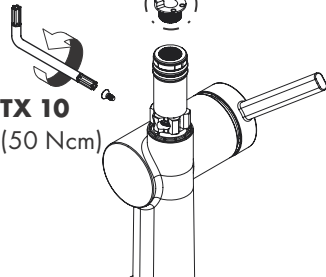
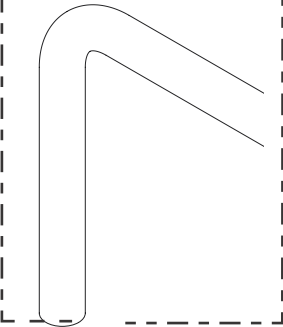
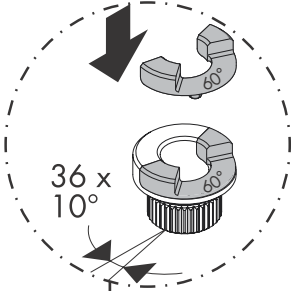
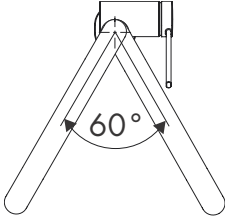



Talis M54 U 220 1jet

72806XXX

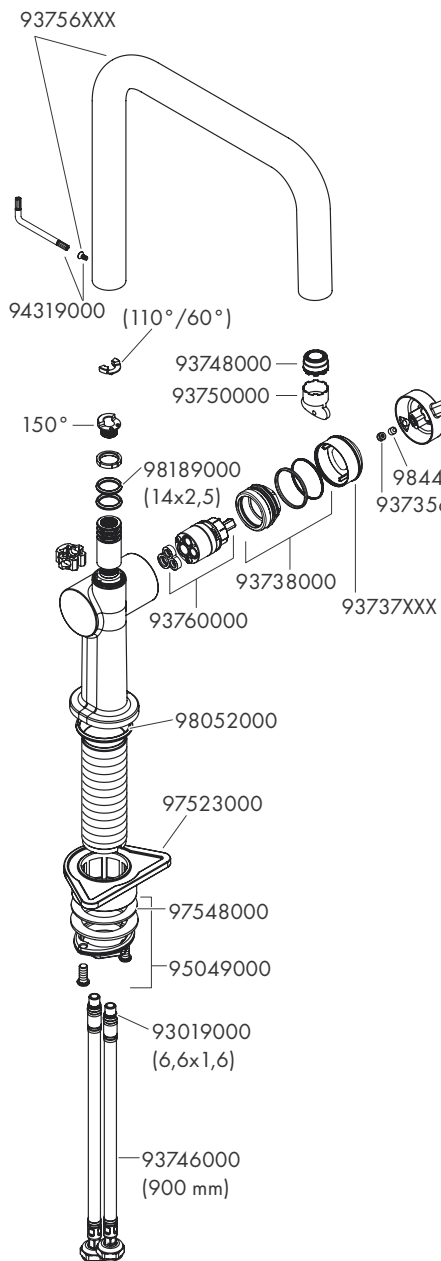

Talis M54 U 220 Eco 1jet

72844XXX

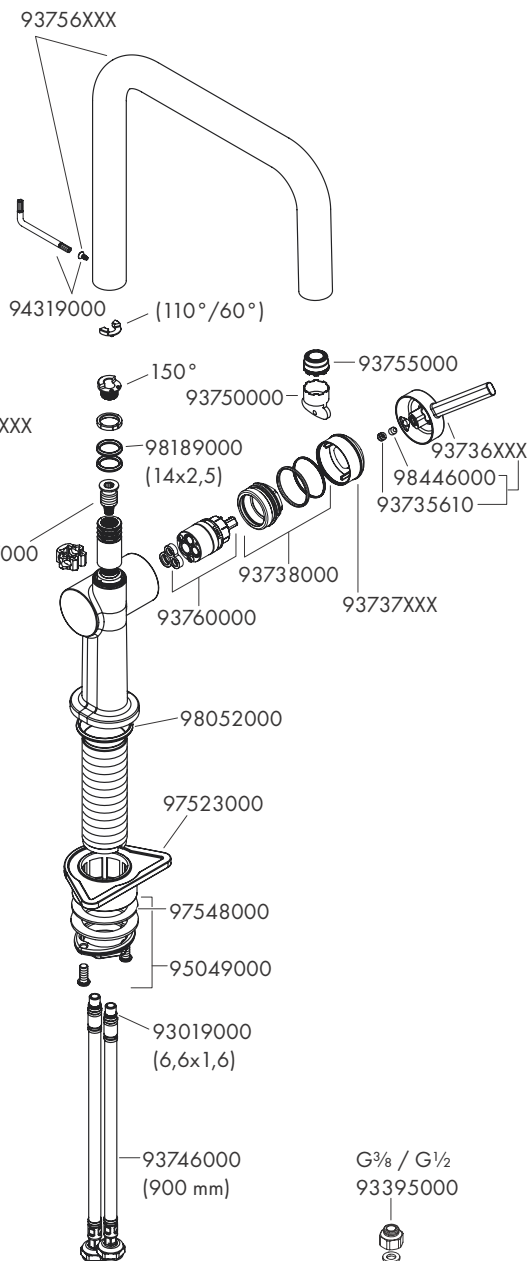



Talis M54 220 1jet

72804XXX

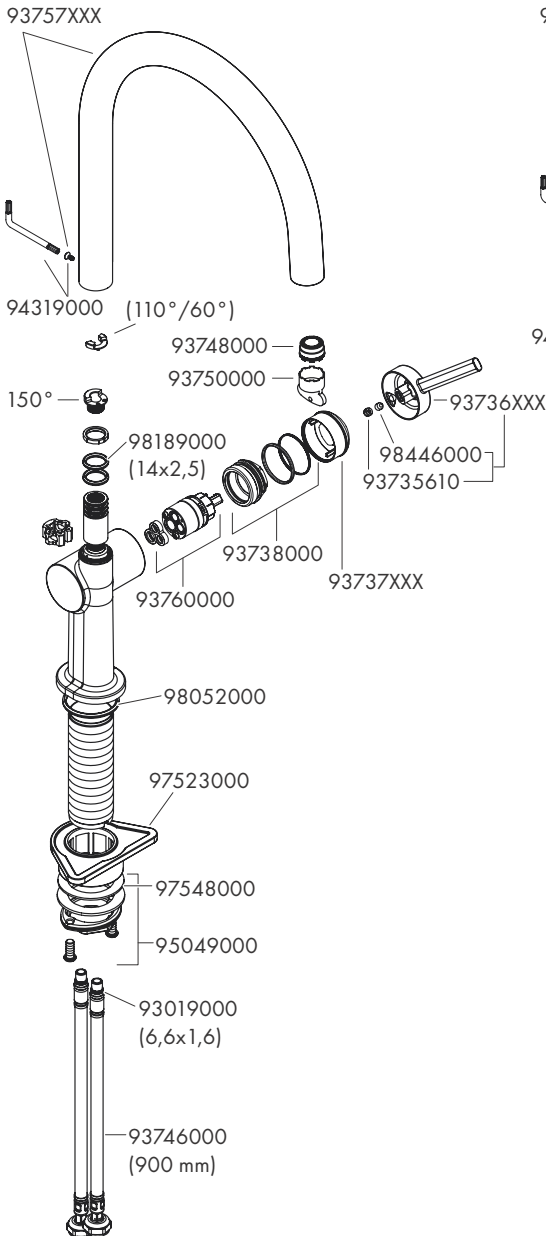

Talis M54 220 Eco 1jet

72843XXX

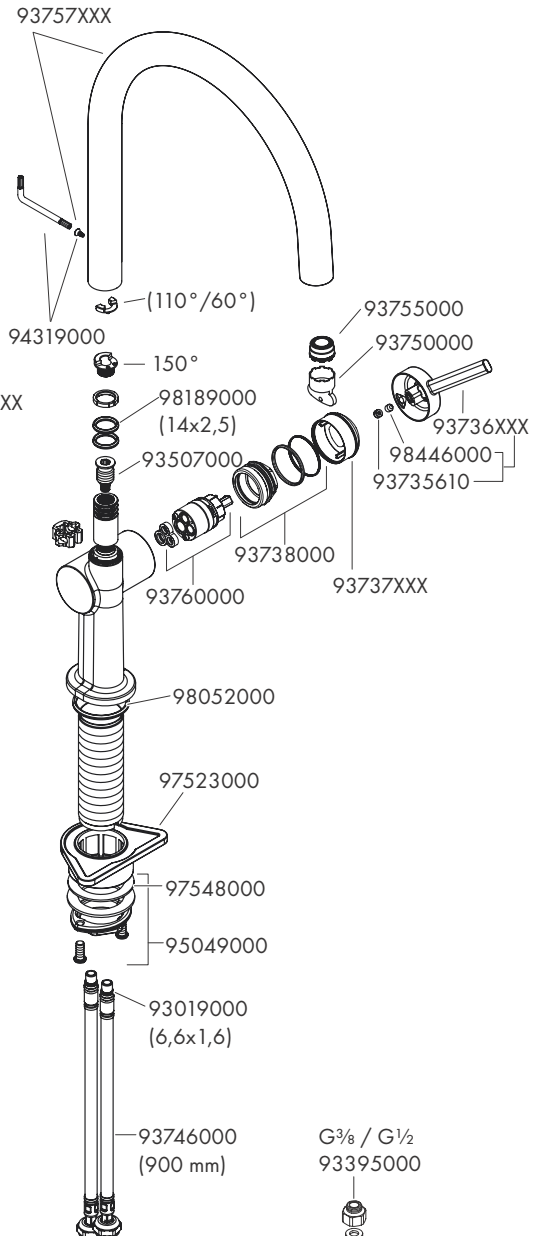

Talis M54 220 1jet
72805XXX

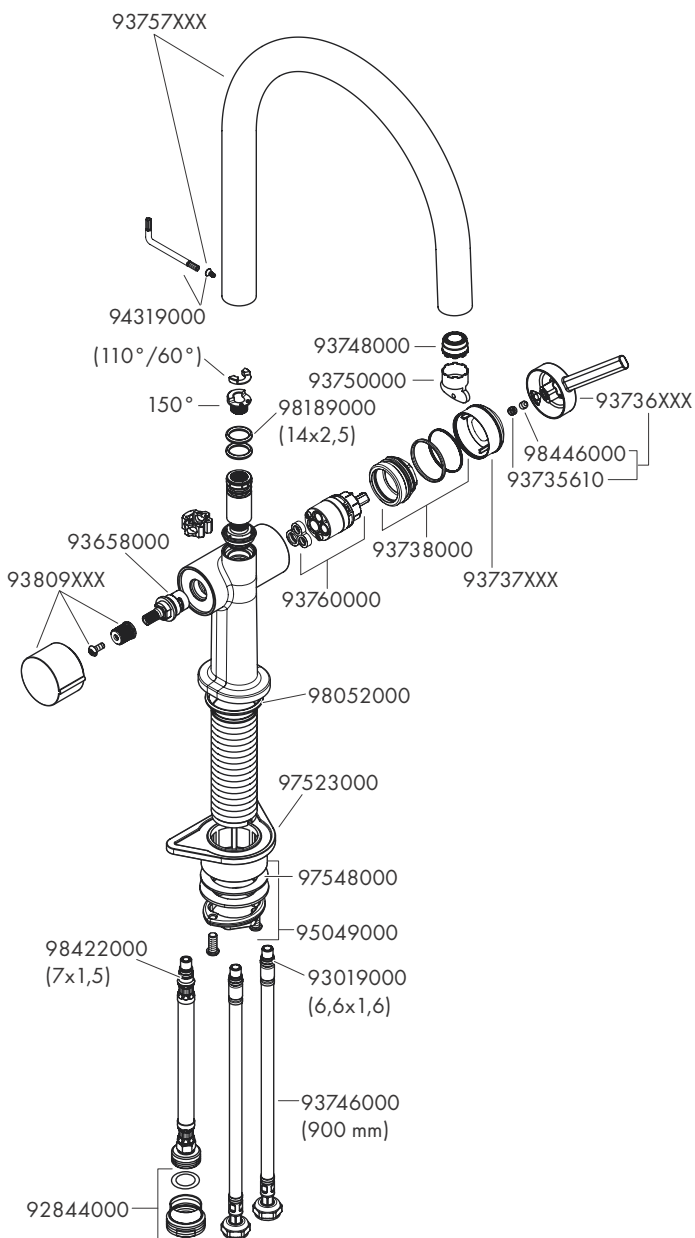



Talis M54 270 1jet

72840XXX

Talis M54 220 1jet

72807XXX

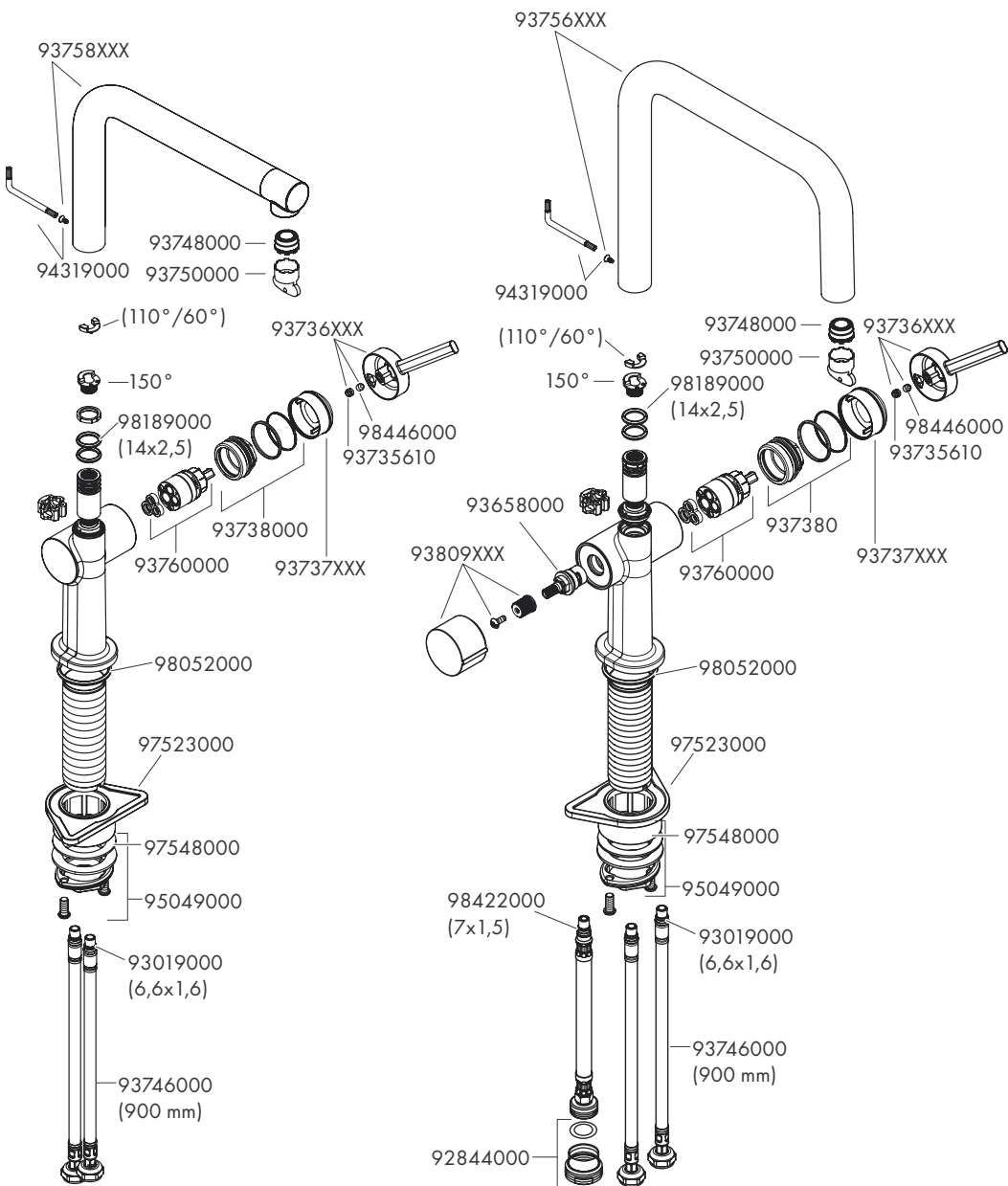



Talis M54 270 1jet

72827XXX

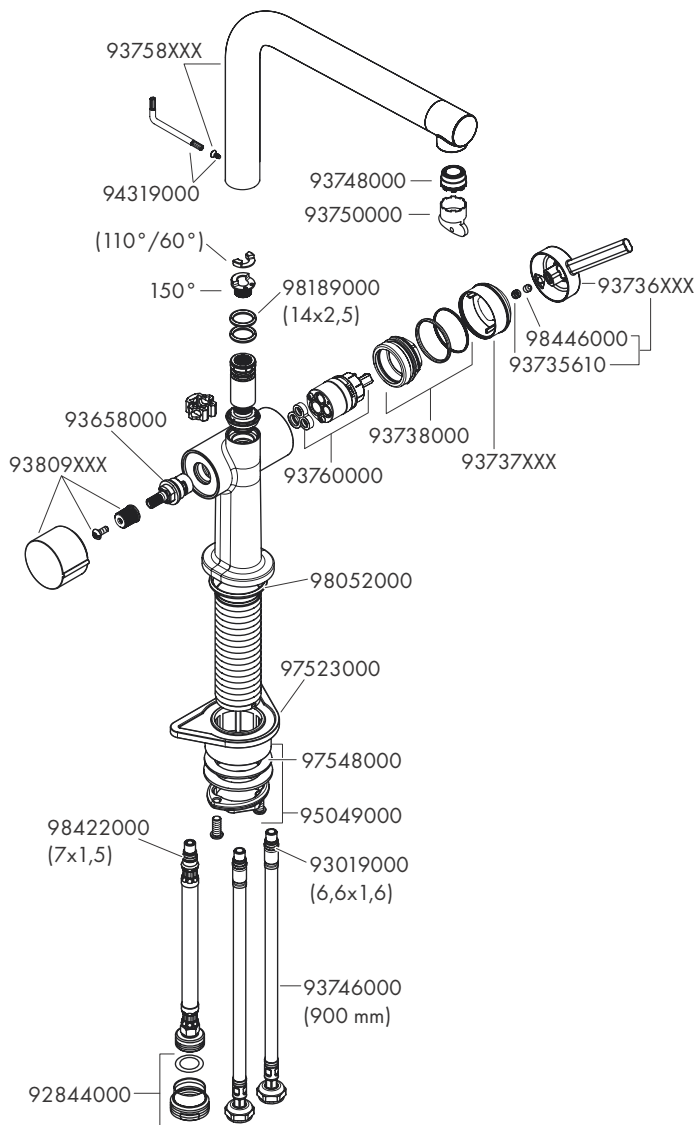



P-IX

DVGW SINTEF NF



ETA



GODKENDT
TIL DRILLEKAVAND

72804XXX	P-IX 29739/IO	DL0136	X
72805XXX	PA-IX 29740/IO	DL0136	X
72806XXX	P-IX 29739/IO	DL0136	X
72807XXX	PA-IX 29740/IO	DL0136	X
72827XXX	PA-IX 29740/IO	DL0136	X
72840XXX	P-IX 29742/IO	DL0136	X
72843XXX	P-IX 29744/IO	DL0136	X
72844XXX	P-IX 29744/IO	DL0136	X

