

- (D) Montageanleitung
- (GB) Assembly instructions
- (NL) Handleiding voor de montage

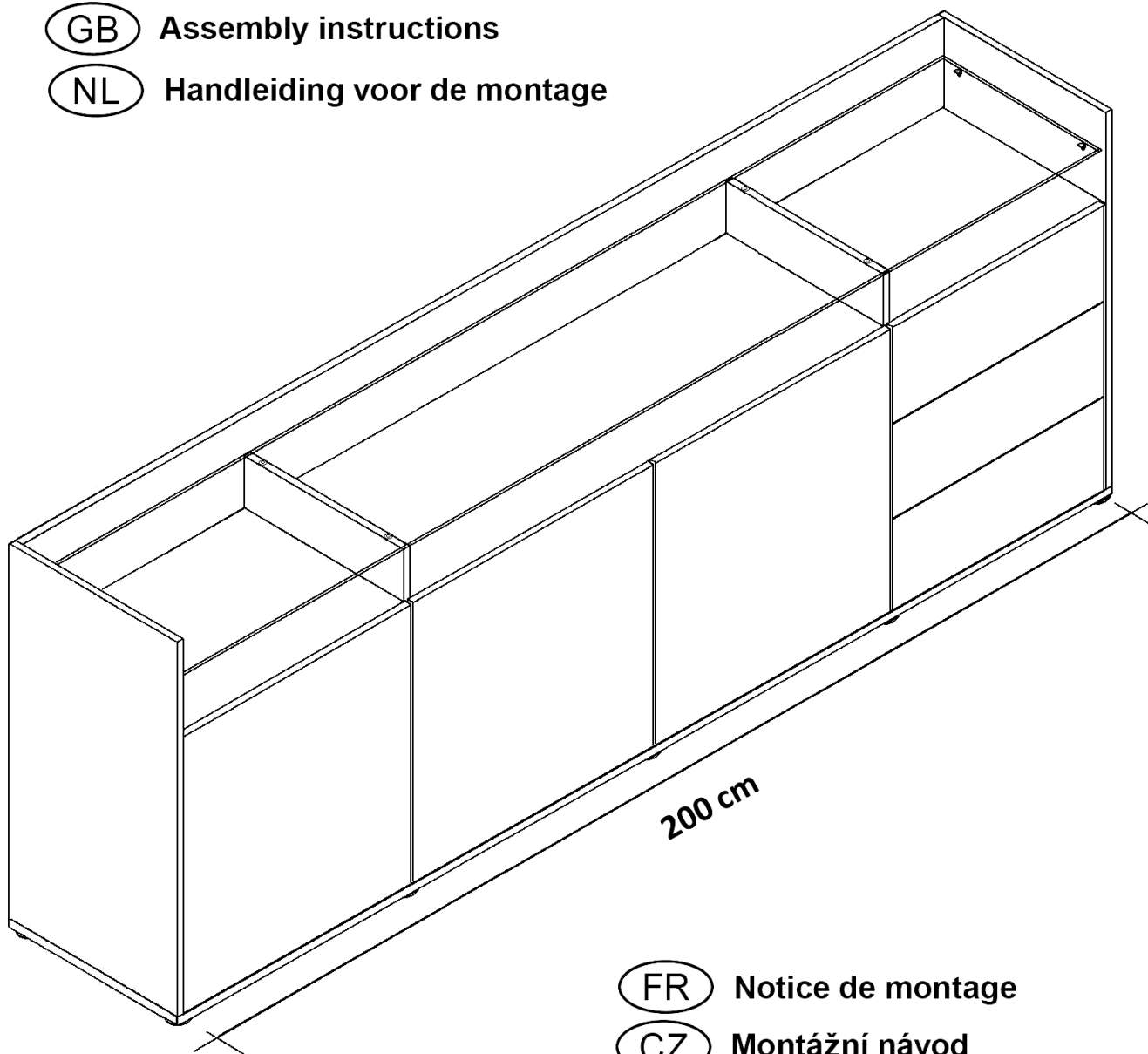

- (HU) Szerelési útmutató
- (PL) Instrukcja montażu
- (RO) Instrucțiuni de montaj

- (FR) Notice de montage
- (CZ) Montážní návod
- (TR) Montaj talimatı
- (IT) Istruzioni di montaggio
- (SK) Návod na montáž
- (RU) Инструкция по монтажу

**Service • Assistenza • Dienstverlening • Serwis
Servis • Szerviz • Сервисная служба**

Name • Nom • Nome • Naam •
Nazwa • Jméno • Názov • Név •
Denumire • İsim • Название

Nr. • No. • N° • Номер • Č • Sz

Typ • Type • Tip • Típus • Tipo •
Тип

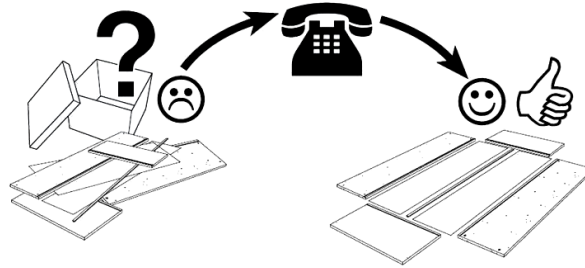
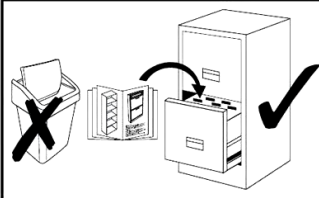

1-1	1x	ca. 1029 x 330 mm
1-2	2x	ca. 455 x 330 mm
2	1x	ca. 1981 x 477 mm

3	1x	ca. 2000 x 395 mm
4	1x	ca. 684 x 395 mm
5	1x	ca. 624 x 315 mm
6	1x	ca. 624 x 315 mm
7	1x	ca. 684 x 395 mm
8	1x	ca. 1969 x 205 mm
9	1x	ca. 1969 x 315 mm

10	3x	ca. 459 x 156 mm
11	3x	ca. 428 x 307 mm
12	3x	ca. 1081 x 89 mm
13	1x	ca. 459 x 476 mm
14	2x	ca. 519 x 476 mm
15	1x	ca. 455 x 300 mm
16	2x	ca. 507 x 300 mm
17	1x	ca. 624 x 315 mm

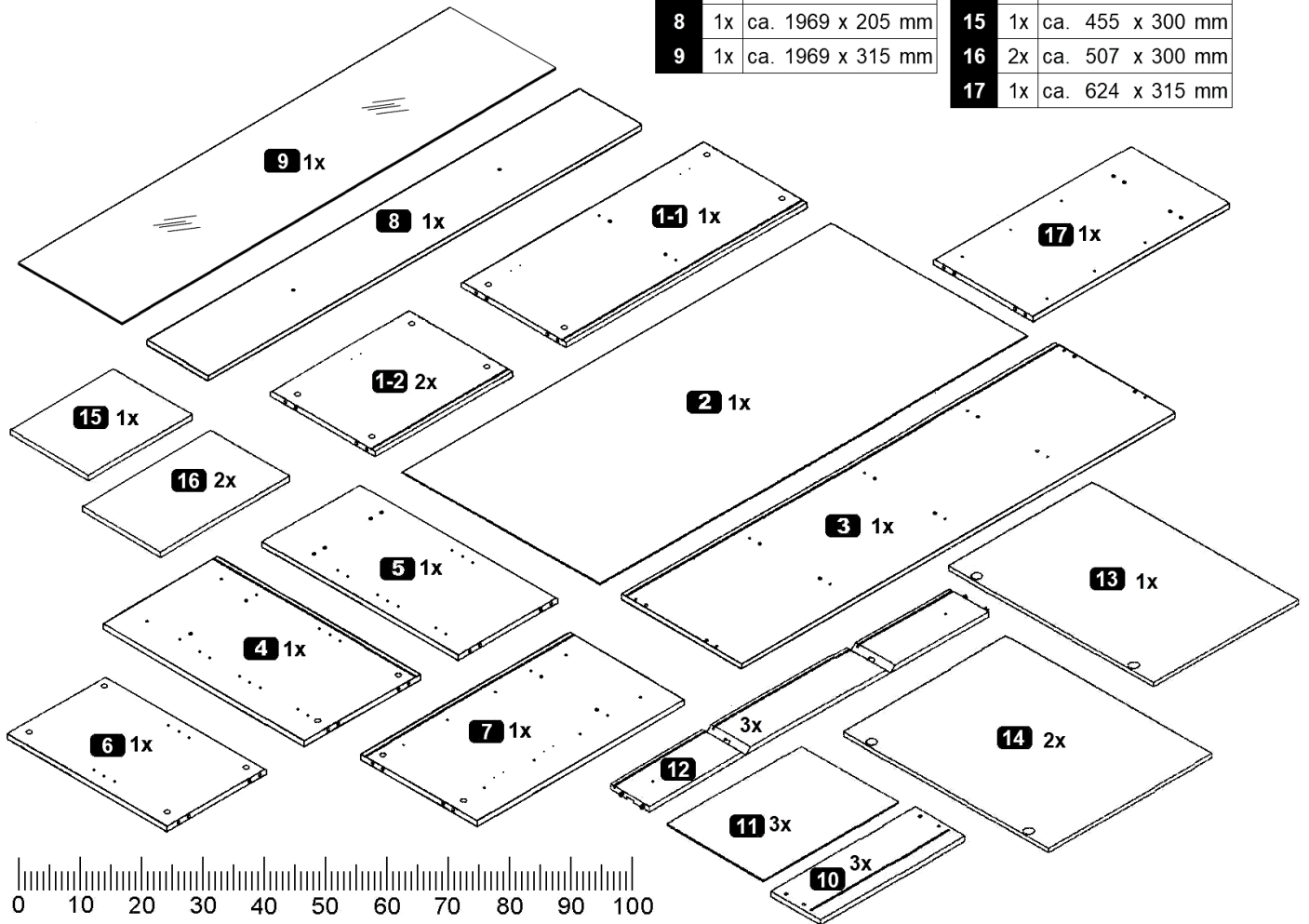

A 8,0 x 30 mm 20x	B 16x	C 24x	D 3,9x9,5mm 6x	E 76 mm 4x	F 16x	G h=4 2x
H Kr. 15 Ø26 2x	I 10x	J 4,0 x 20 mm 10x	K 2,7 x 20 mm 12x	L 17 x 310 mm 6x	M 6,3 x 13 mm 6x	N M4,0 x 9 mm 6x
O 6,3 x 19 mm 6x	P 2x	Q 4,0 x 13 mm 8x	R h=2 4x	S Kr. 8 Ø26 4x	T 4x	U 3,0 x 40 mm 2x
V h=6mm 6x		W 1x				

1

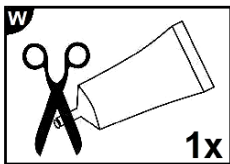
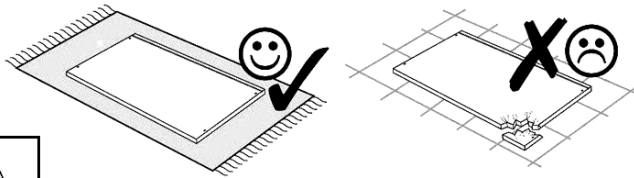

- D Leim
- GB Glue
- FR Colle
- IT Colla
- NL Lijm
- PL Klej
- CZ Lepidlo
- SK Glej
- HU Enyv
- RO Adeziv
- TR Tutkal
- RU Клей

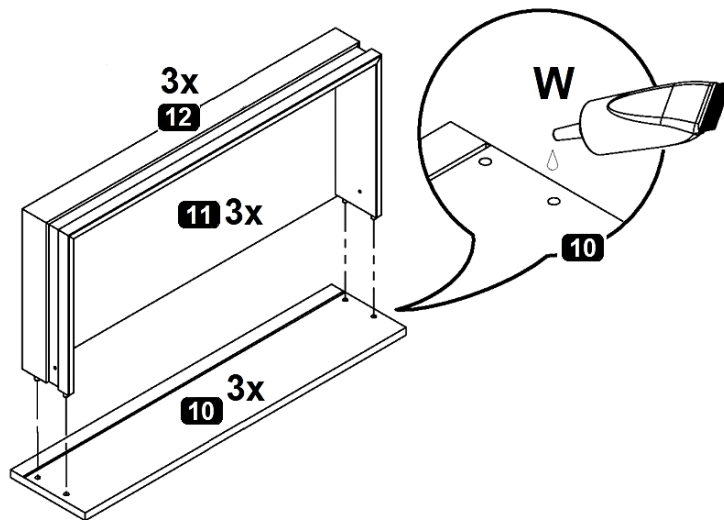
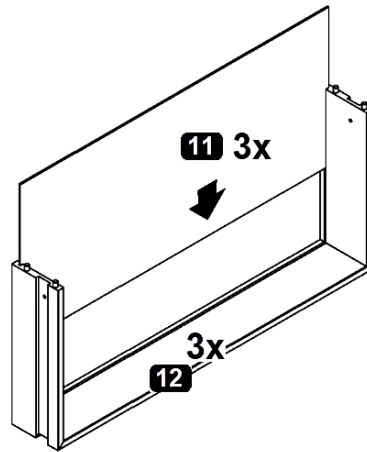
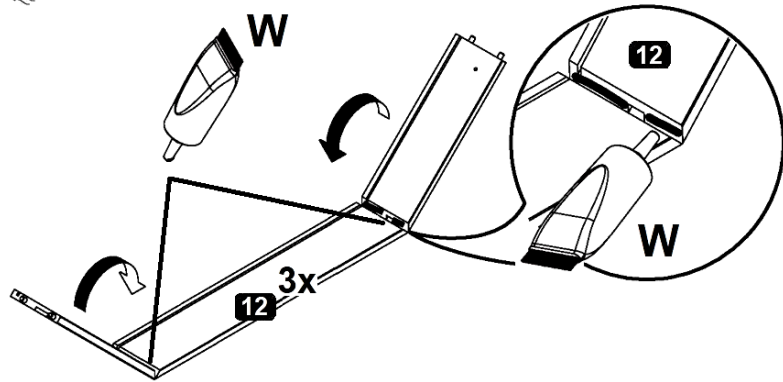

20min



2

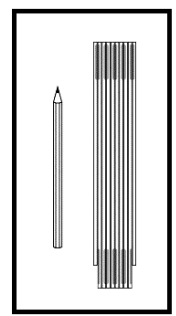
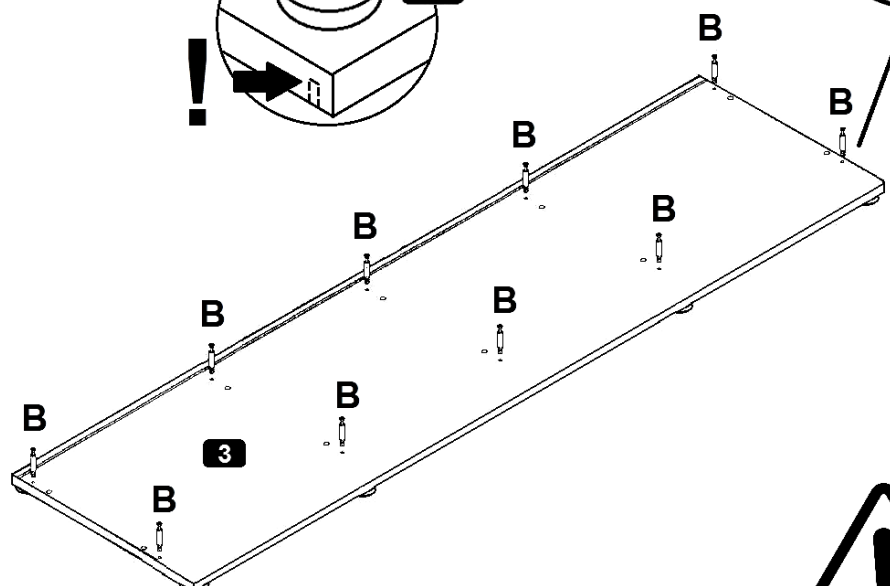
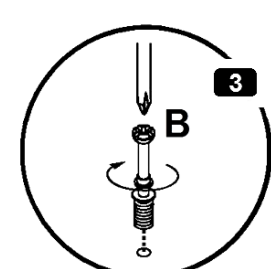
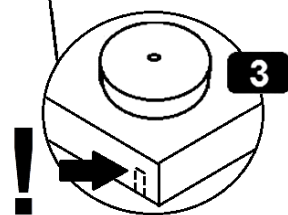
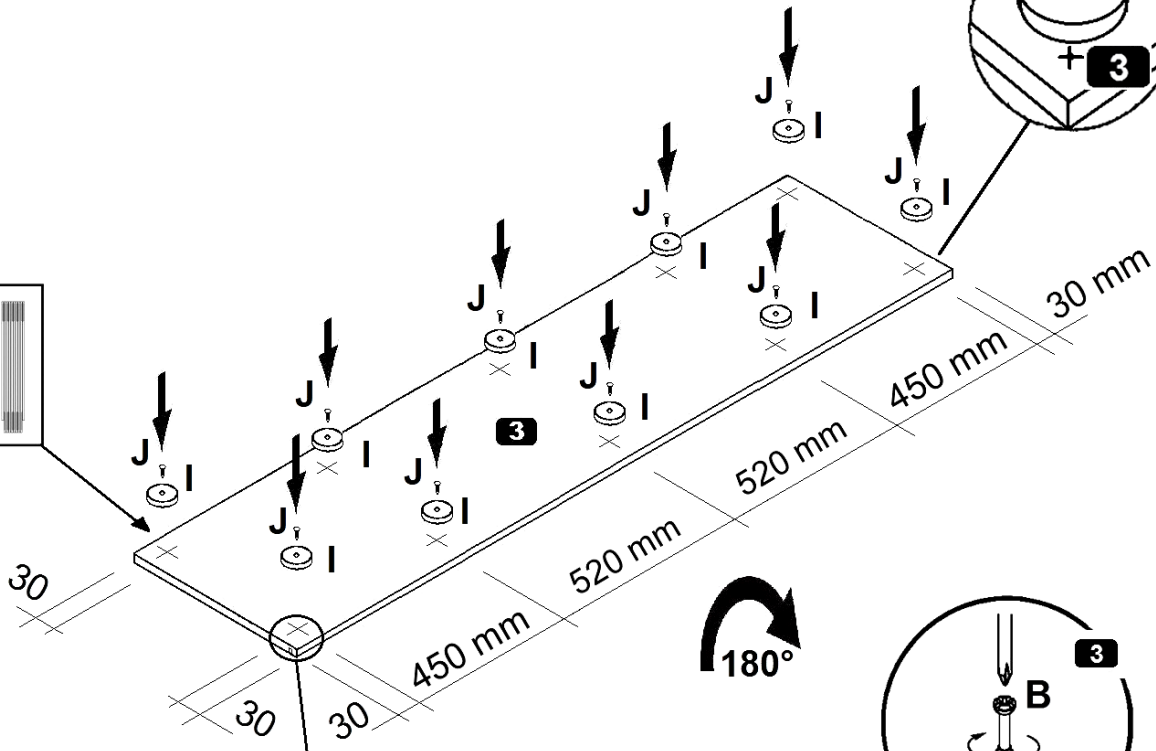
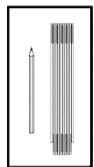
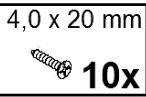
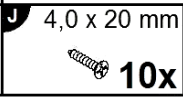
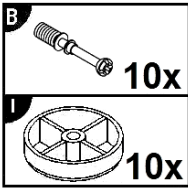
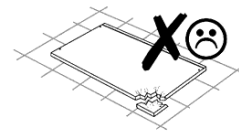
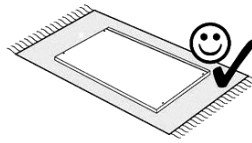
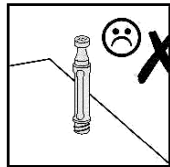
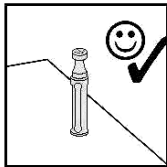

3

D 3,9x9,5mm 4x

A 8,0 x 30 mm 14x





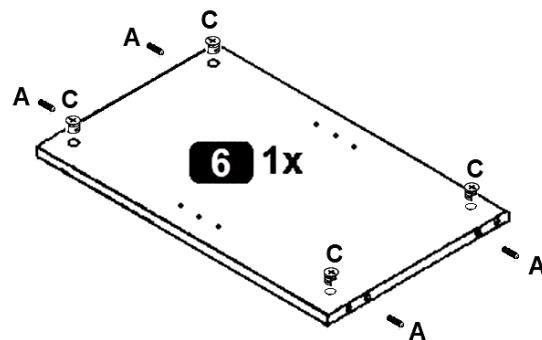
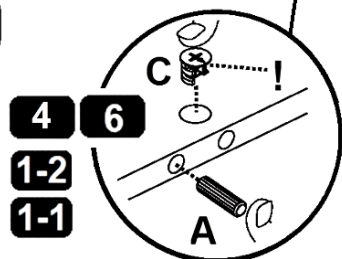
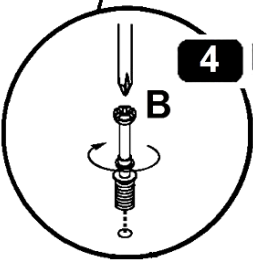
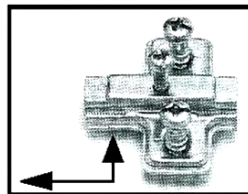
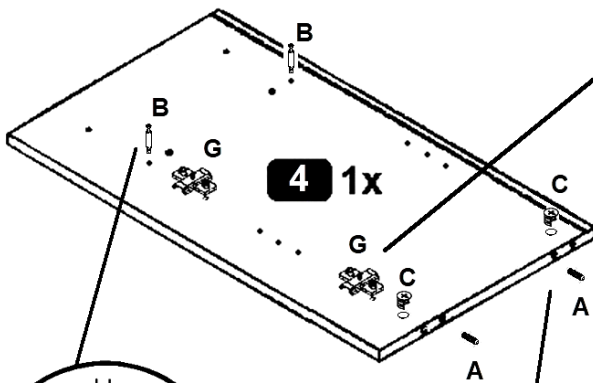
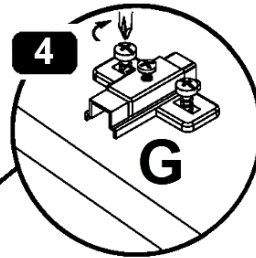
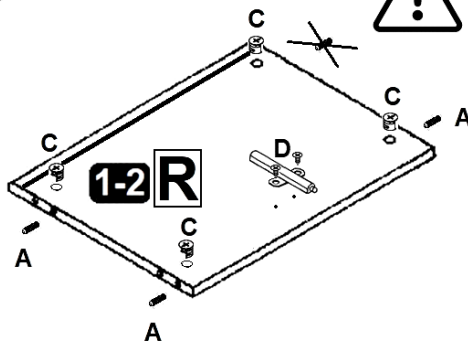
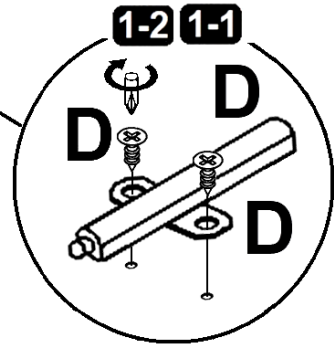
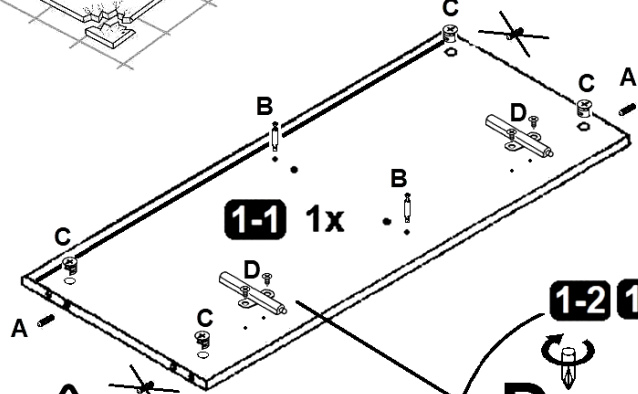
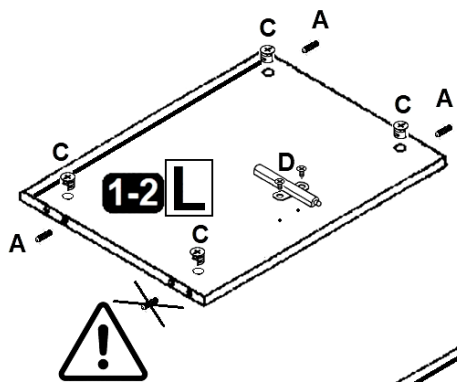
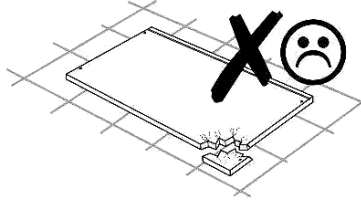
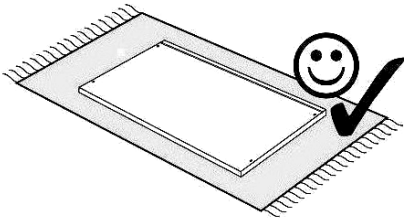
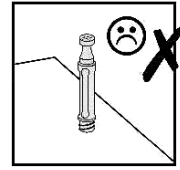
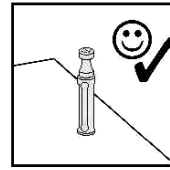

B 4x



C 18x

G h=4 2x

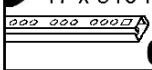



4

A 8,0 x 30 mm  4x	B  2x	C  4x	D  2x
L 17 x 310 mm  6x	M h=6mm  6x		

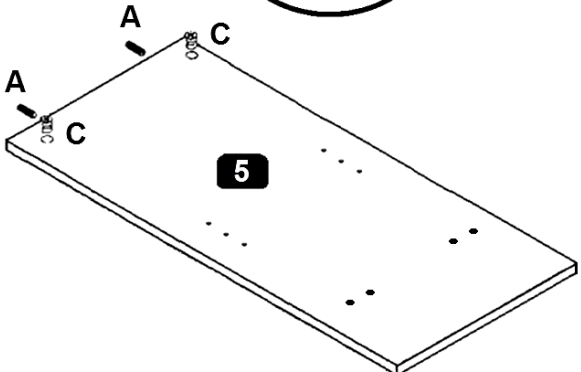
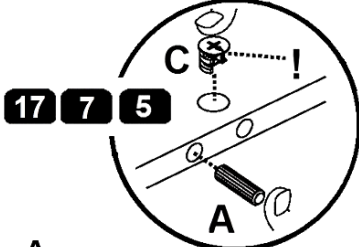
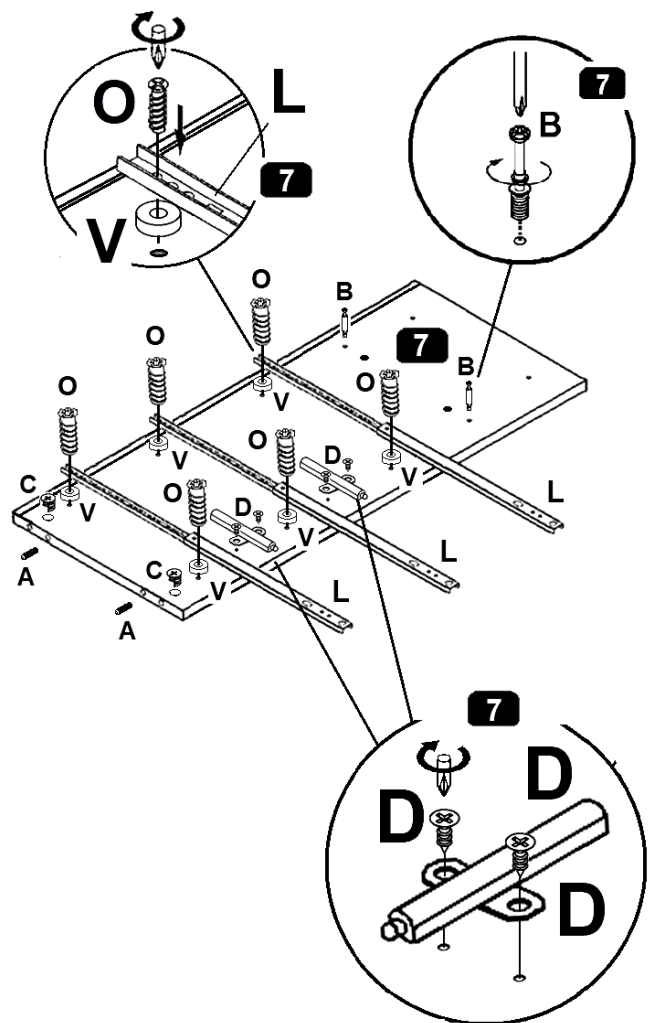
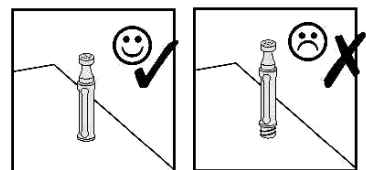
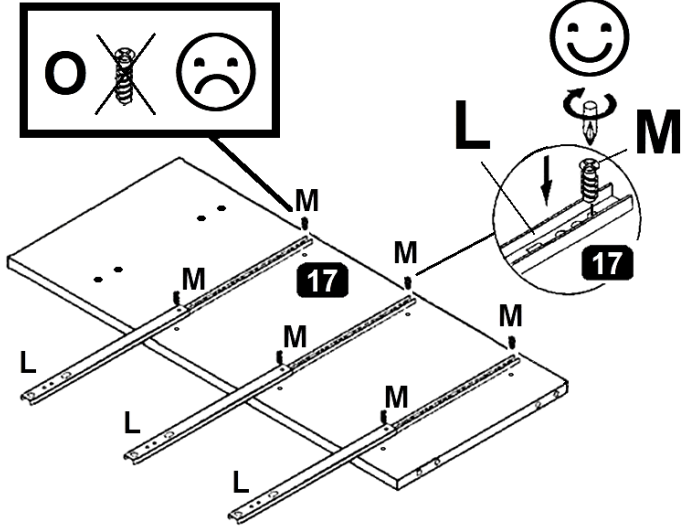
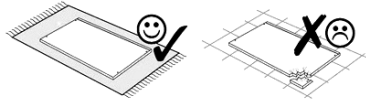
O 6,3 x 19 mm  6x	M 6,3 x 13 mm  6x
---	---



5

A	8,0 x 30 mm	
		2x
C		2x
R	h=2	
		4x

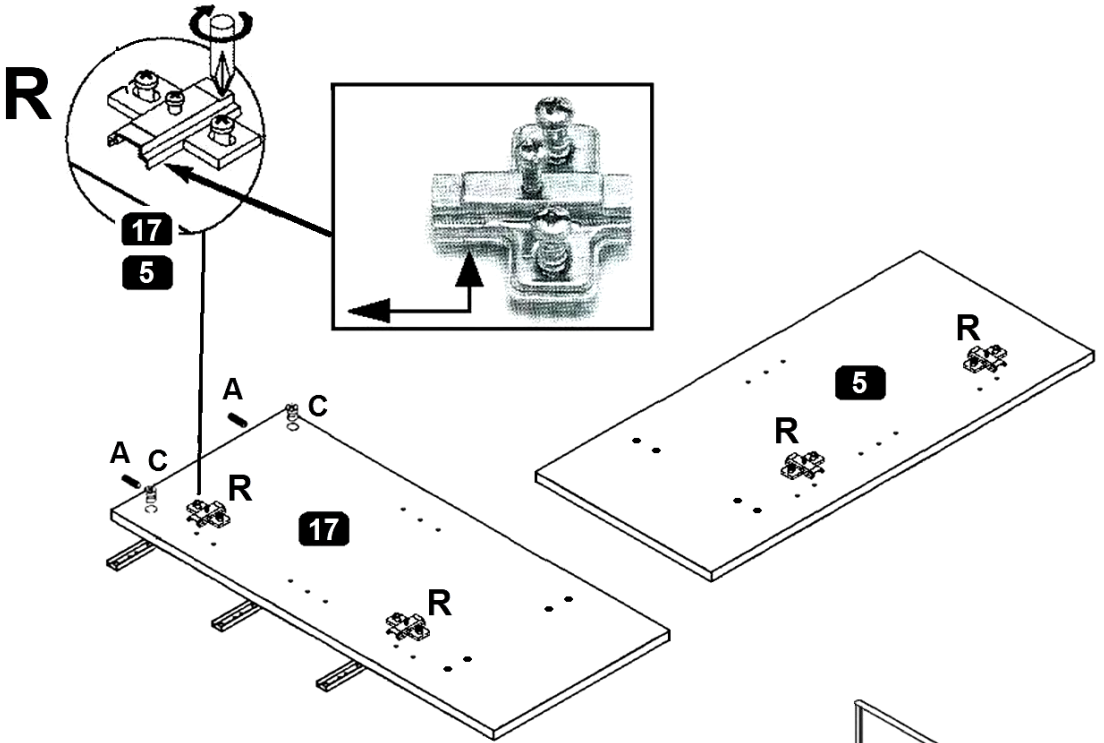

6

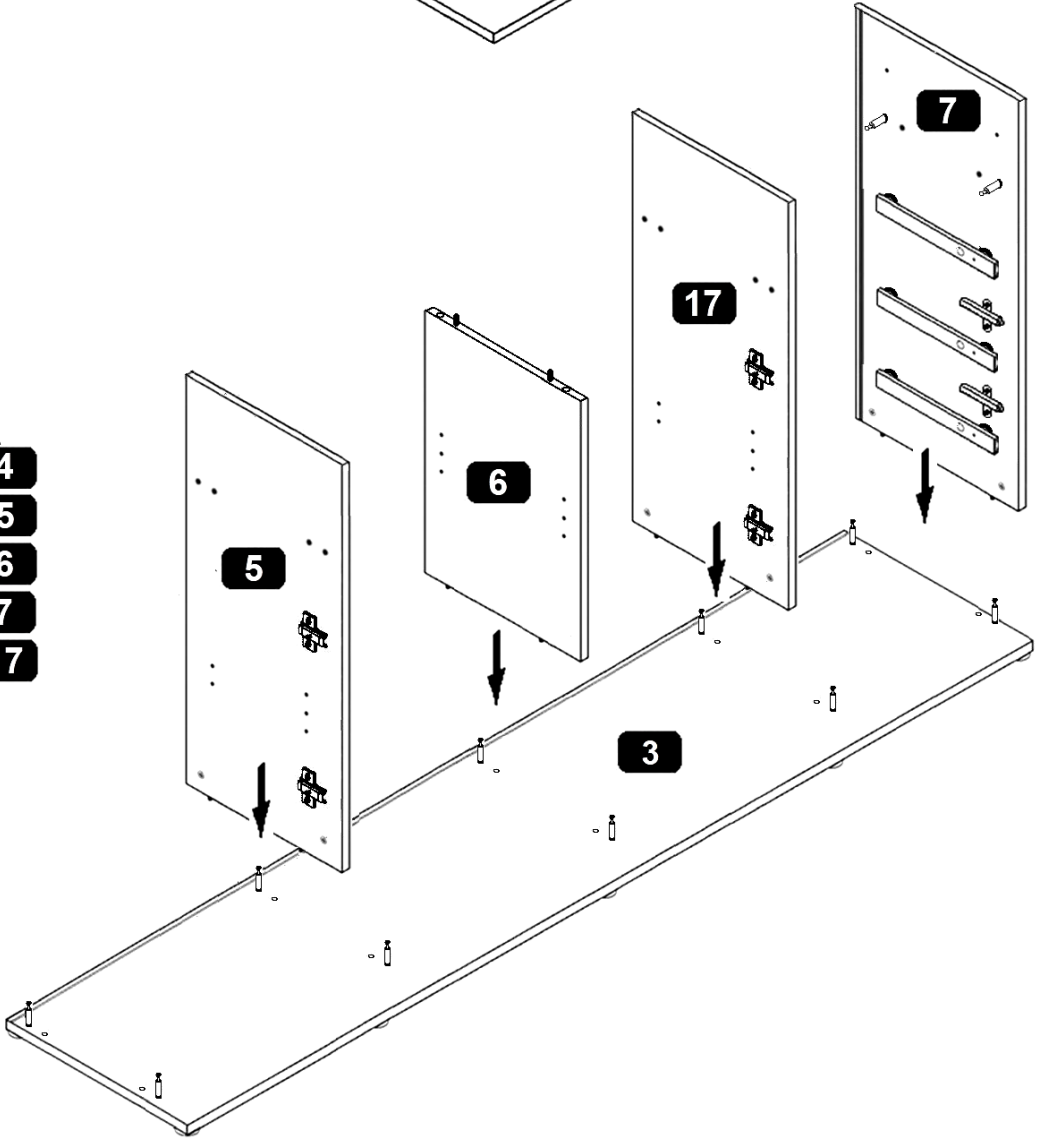
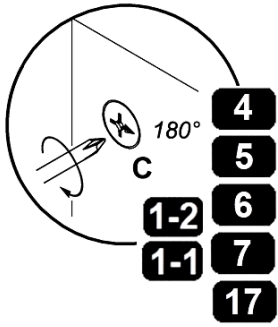

7

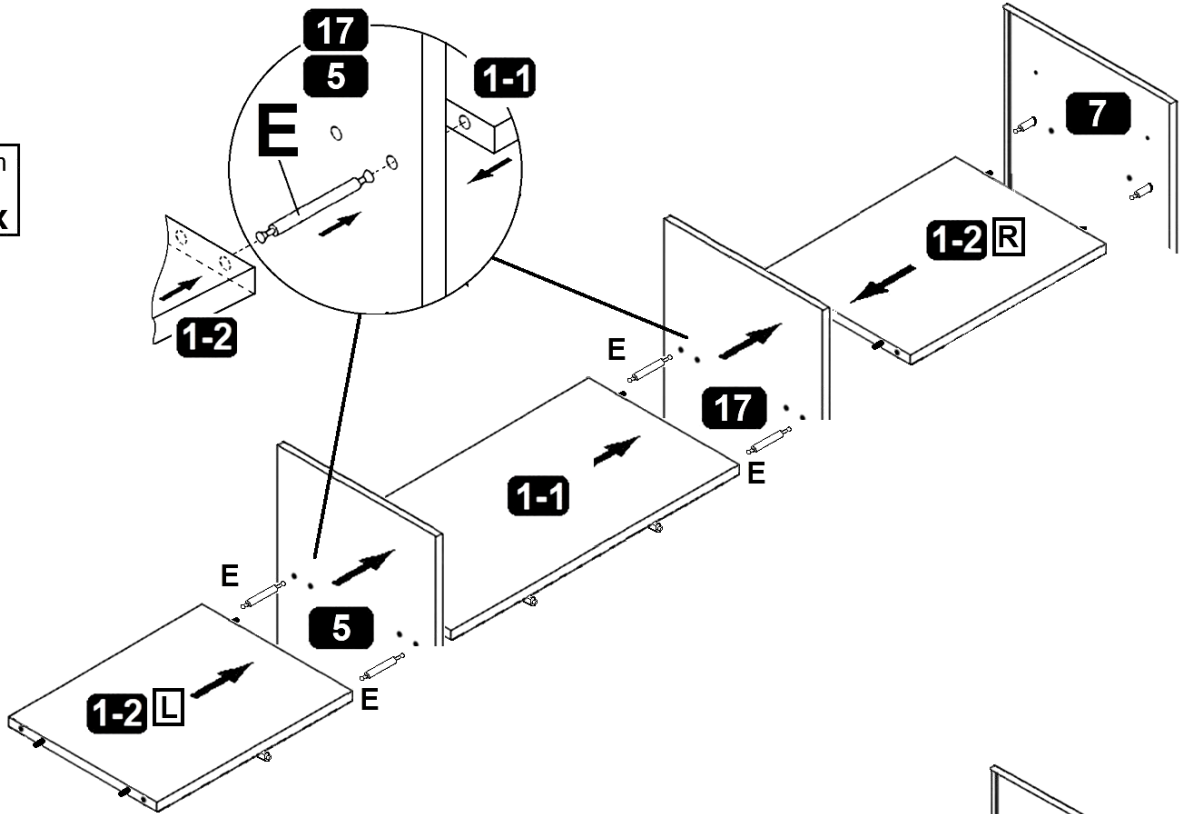
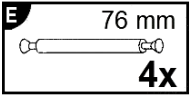

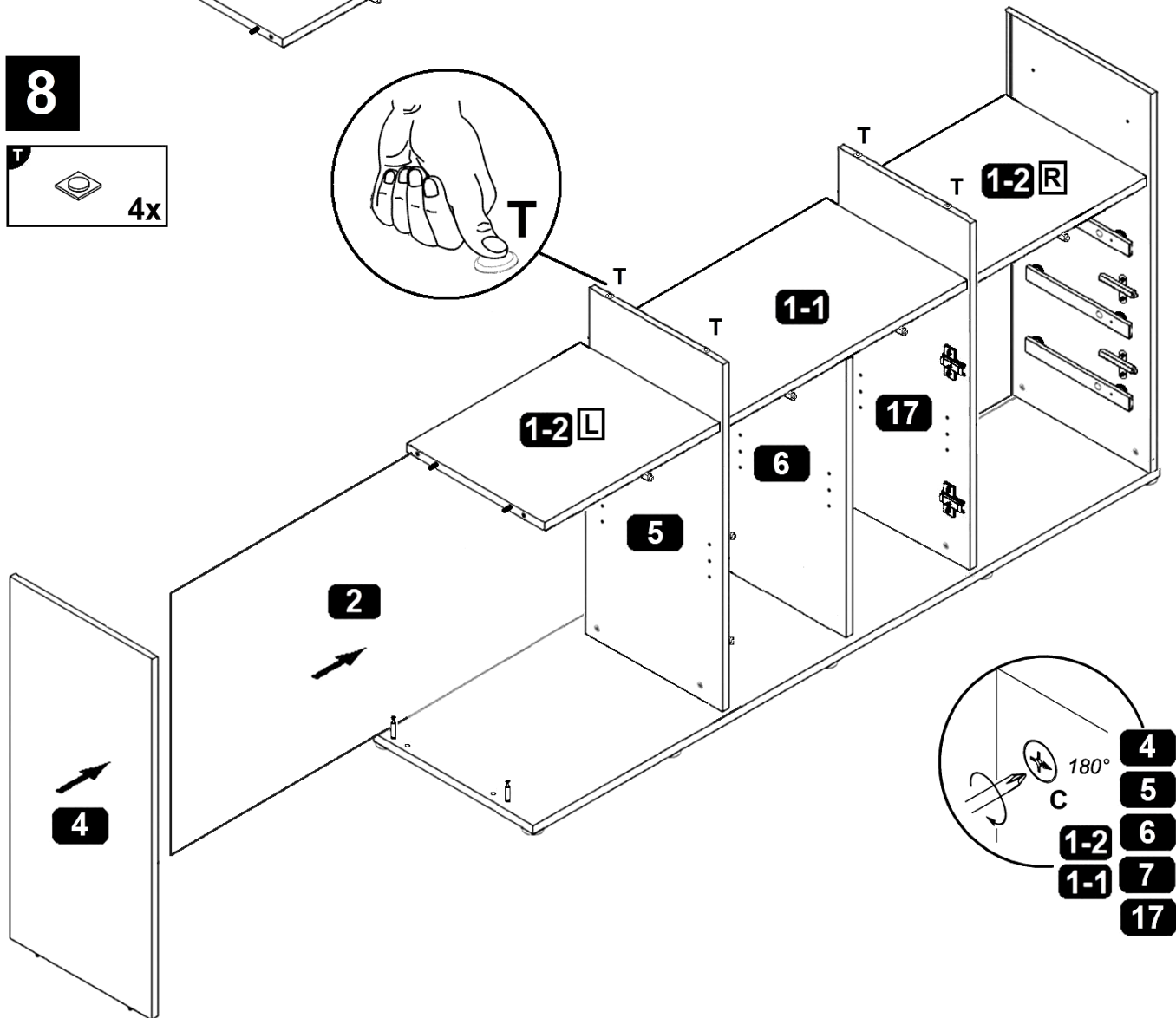
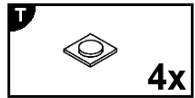

8



- 4**
- 5**
- 6**
- 1-2**
- 1-1**
- 7**
- 17**

9

K 2,7 x 20 mm
 12x
F
 16x
U 3,0 x 40 mm
 2x

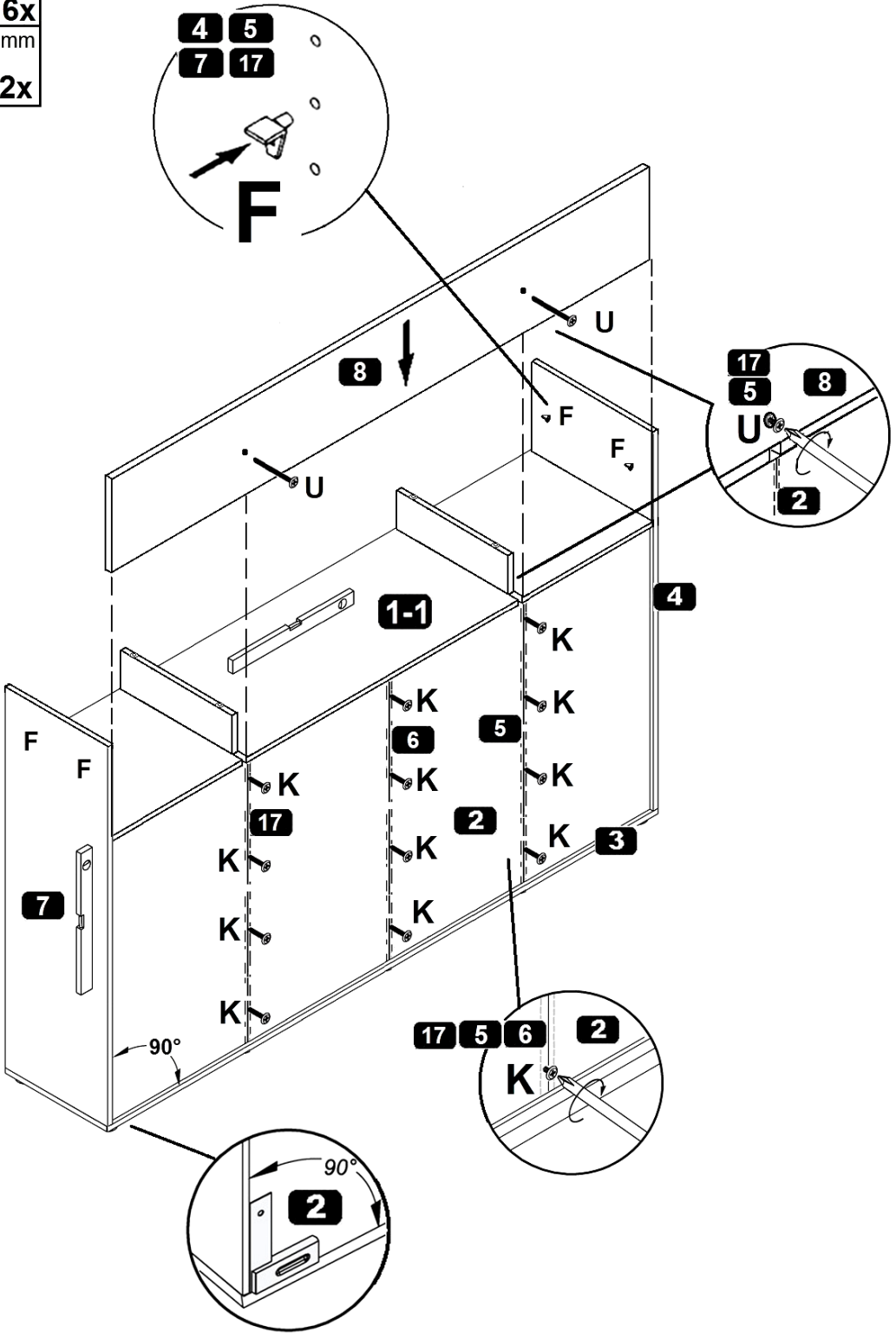

10

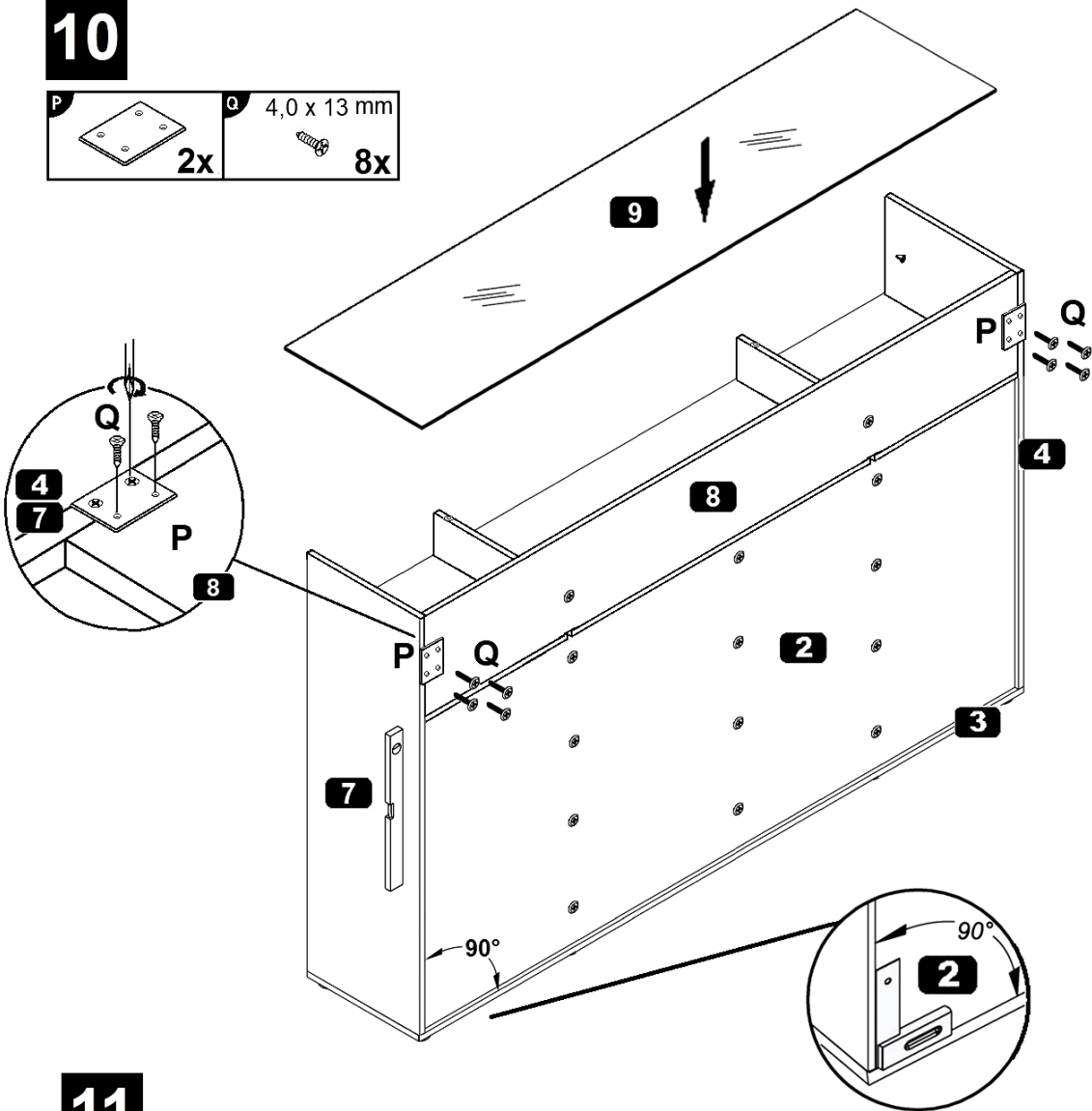
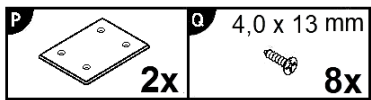

11

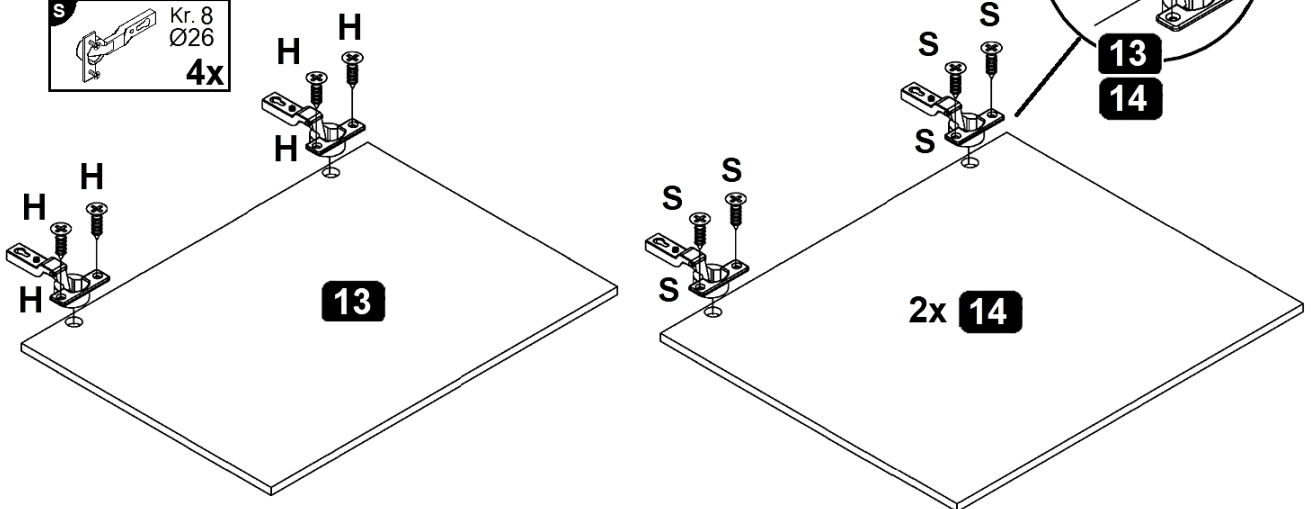
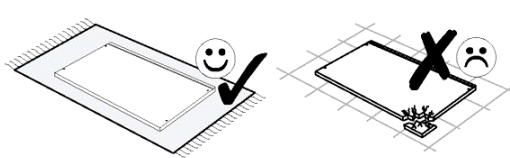
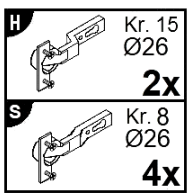

12

N M4,0 x 9 mm
6x

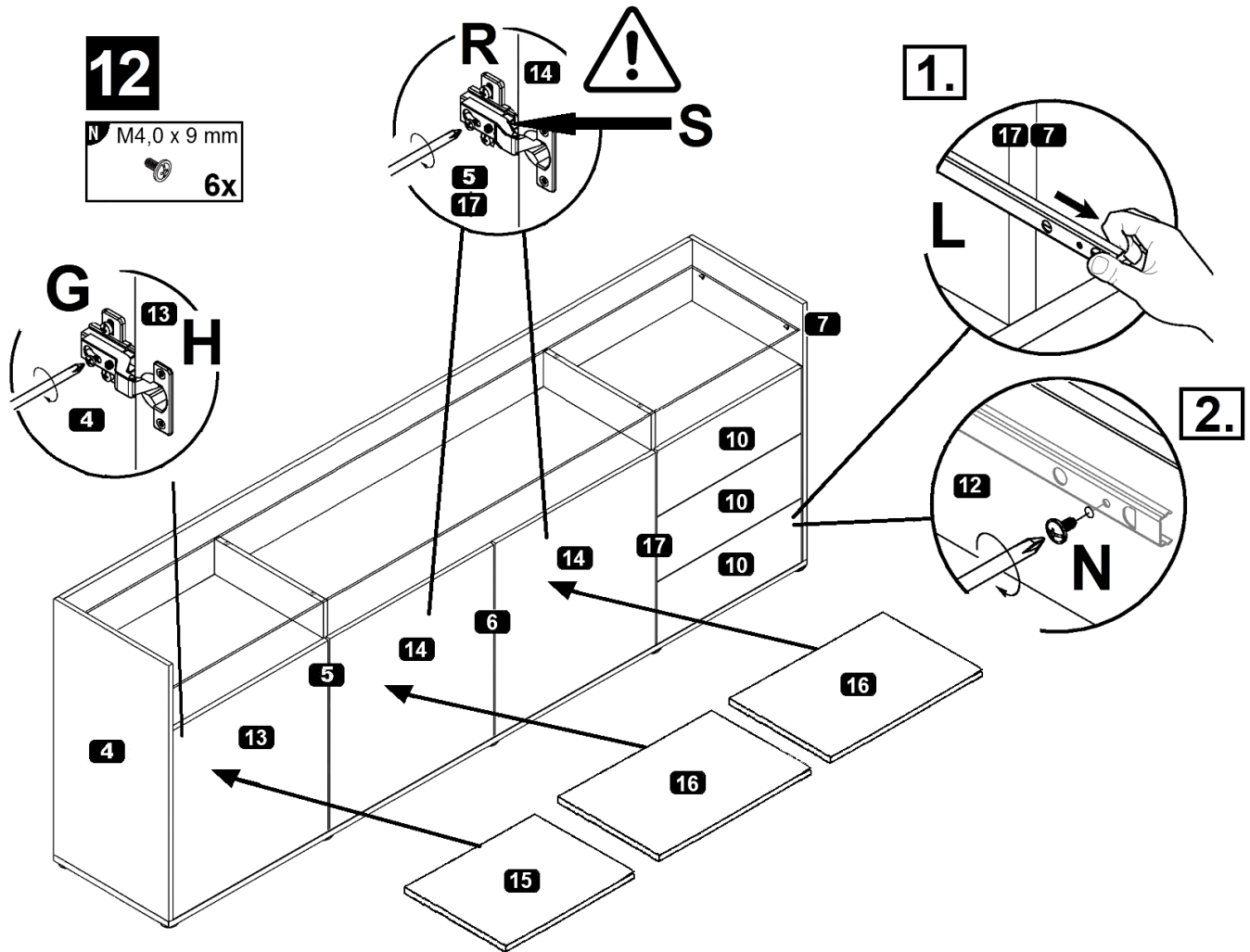

- (D) Push-To-Open einstellen
- (GB) Adjusting the Push-To-Open
- (FR) Régler les Push-To-Open
- (IT) Sistemare Push-To-Open
- (NL) Push-To-Open instellen
- (PL) Nastawić Push-To-Open
- (CZ) Vyrovnajte Push-To-Open
- (RO) Nastavenie Push-To-Open
- (HU) Állítsa be az Push-To-Open
- (SK) Reglare Push-To-Open
- (TR) Push-To-Open ayarlanması
- (RU) Регулировка Push-To-Open

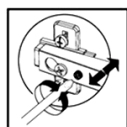
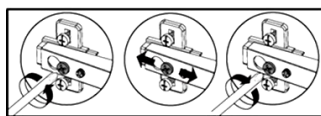
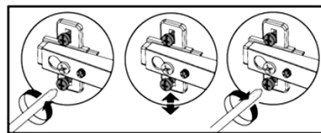
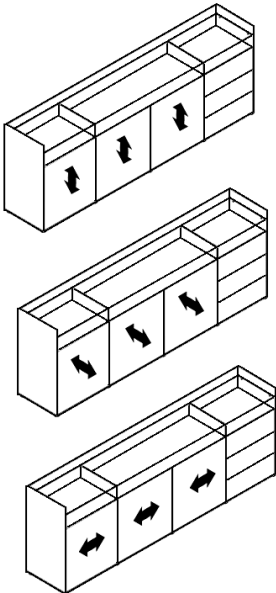
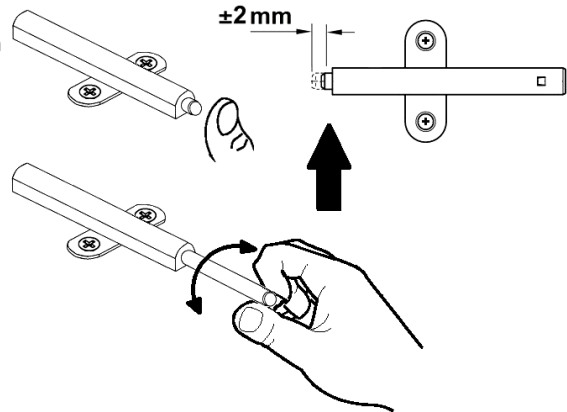

- (D) Türen einstellen
(Scharniere justieren)
- (GB) Adjusting the doors
(adjusting the hinges)
- (FR) Régler les portes
(ajuster les charnières)
- (IT) Sistemare le porte
(regolare le cerniere)
- (NL) Deuren instellen
(scharnieren afstellen)

- (PL) Nastawić drzwi
(wyregulować zawiasy)
- (CZ) Vyrovnajte dvířka
(seřid'te závěsy)
- (RO) Nastavenie dverí
(nastavenie závesov)
- (HU) Állítsa be az ajtókat
(állítsa be a zsanérokot)
- (TR) Reglare uşi
(ajustare balamale)
- (SK) Kapıların ayarlanması
(menteselerin seviye ayarı)
- (RU) Регулировка дверей
(регулировка шарнира)