

(D) Montageanleitung

(I) Istruzioni di montaggio

(CZ) Montážní návod

LKZ 41194

(GB) Assembly instructions

(NL) Handleiding voor de montage

(SK) Návod na montáž

(F) Notice de montage

(PL) Instrukcja montażu

(HU) Szerelési útmutató

(RO) Instrucțiuni de montaj

(TR) Montaj talimatı

(RU) Инструкция по монтажу

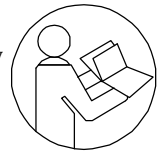

## RIBE R-48

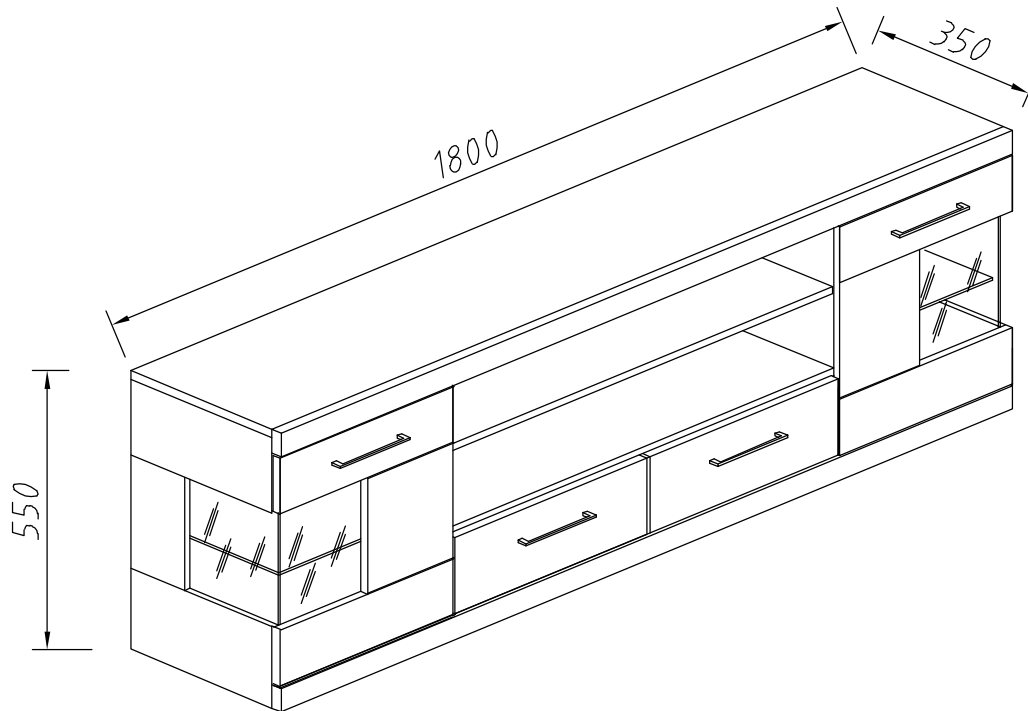



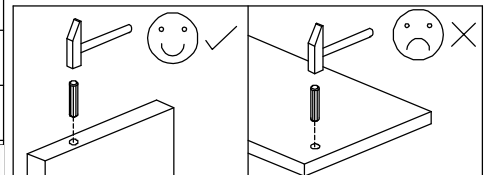
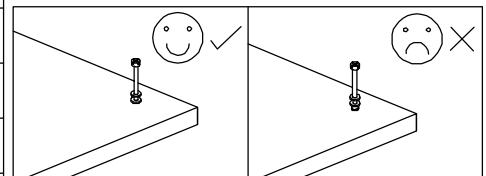
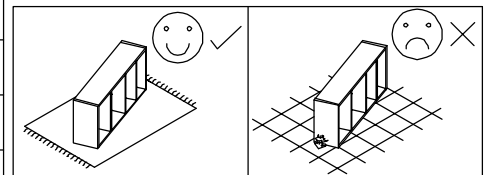
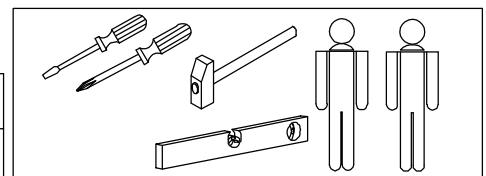





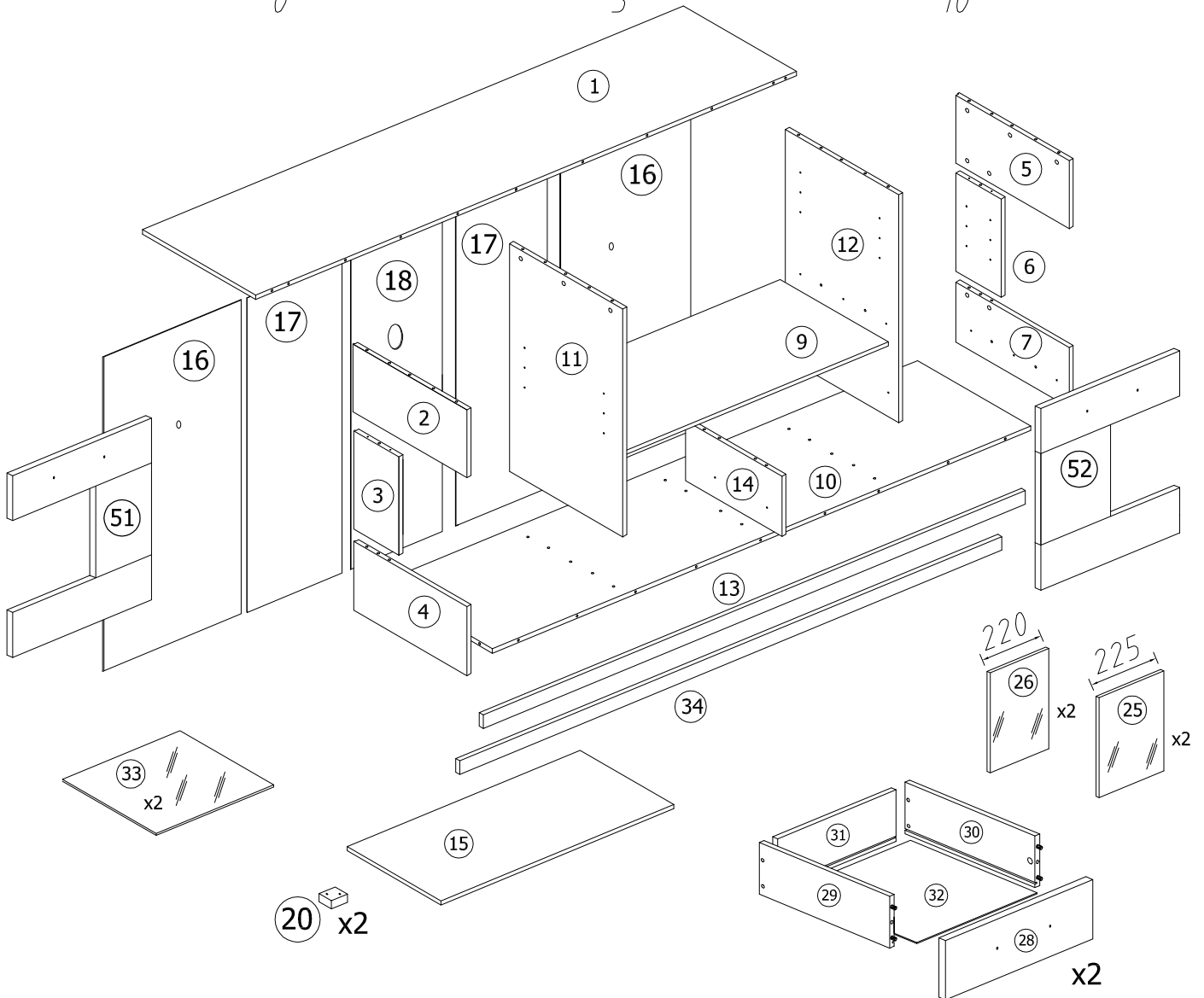
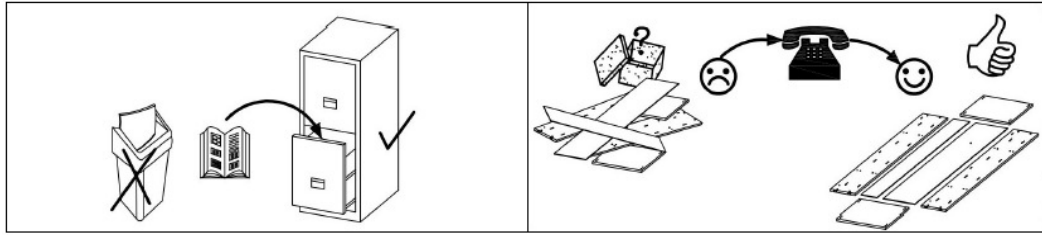

















! Uwaga • Achtung • Attention • Caution • Figyele • Attenzione • Opgelet Atentje • Upozornenie • Dikkat • Upozornění • ВНИМАНИЕ !	
(D)	Bitte nur mit einem Staubtuch oder leicht feuchtem Lappen reinigen. Keine scheuernden Putzmittel verwenden
(GB)	Please only with a duster or a damp cloth. Do no use any abrasive cleaners
(F)	Le nettoyage se fait uniquement à l'aide d'un torchon ou d'une serviette légèrement mouillée
(RO)	Curățarea trebuie efectuată numai o cârpă sau cu un prosop ușor umezit Nu utilizați agenți de curățare abrazivi
(I)	Pulire esclusivamente con un panno o un asciugamano umido
(NL)	Reinig alleen met een stofdoek of een lichtjes vochtige doek Gebruik geen schurende poetsmiddelen
(PL)	Czyszczenie należy wykonać wyłącznie za pomocą ściereczki lub lekko nawilżonego ręcznika. Nie stosować środków czyszczących do szorowania
(TR)	Lütfen sadece bir toz beziyile veya hafif nemli yumuşak bir bezle siliniz. Aşındırıcı temizlik malzemeleri kullanmayınız
(CZ)	Čistění je nutné vykonávat výhradně pomocí utěrky nebo lehce navlhčeného ručníku. Nepoužívejte čisticí prostředky obsahující abrazivní částice
(SK)	Čistení je nutné vykonávať výhradne pomocí utierky alebo ľahko zvlhnutým ručníkom Nepoužívajte čisticí prostriedky obsahujúci abrazívni častice
(HU)	A tisztítás kizárólag törlőruha vagy enyhén nedvesített törlőköző segítségével végezhető. Súroló hatású tisztítószerket nem szabad használni
(RU)	Очищайте от пыли тряпкой или слегка влажной ветошью. Не допускается применение чистящих средств, не пред-назначенных для ухода за мебелью.



- (D) Servicekarte      (RO) Carte de service      (PL) Karta serwisowa      (SK) Služobný preukaz  
 (GB) Service card      (I) Carta di servizio      (TR) Servis karti      (HU) Szerviz kártya  
 (F) Carte de service      (NL) Dienst kaart      (CZ) Servisni karta      (RU) Инструкция по монтажу

# RIBE R 48



(A)  x48	(B)  x48	(C)  x29	(D)  $\phi 8$ x42	(E)  x4	(J)  x2	(K)  x1	(M)  $\phi 5 \times 9$ x8	(N)  $\phi 7 \times 50$ x16	(R)  $\phi 1$ x60	(P)  M 4 x 22 x8
(AB)  $\phi 3,5 \times 16$ x8	(AO)  x10	(BX)  x8	(CB)  $\phi 6,3 \times 13$ x8	(CC)  $\phi 8$ x4	(CN)  $\phi 3 \times 16$ x44	(CU)  L-300 x4	(CW)  L-300 x4	(DB)  $\phi 4 \times 40$ x4	(FD)  x32	(FG)  x6
(FN)  x4	(ZC)  $\phi 35$ x4	(ZP)  x4								

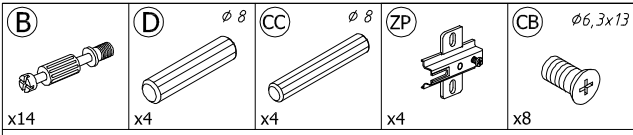

1

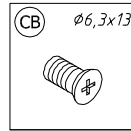
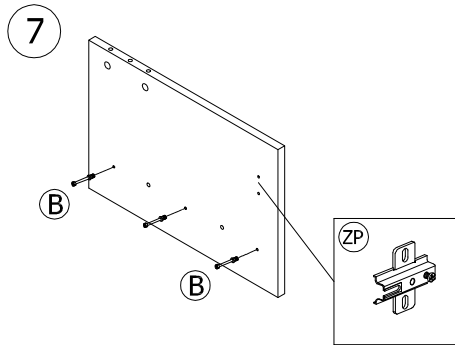
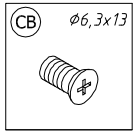
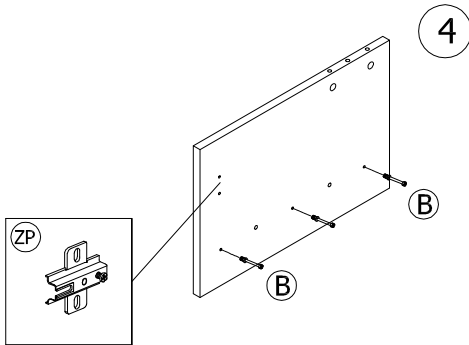
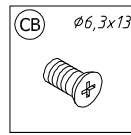
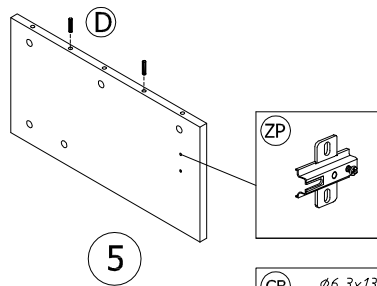
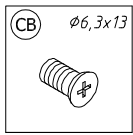
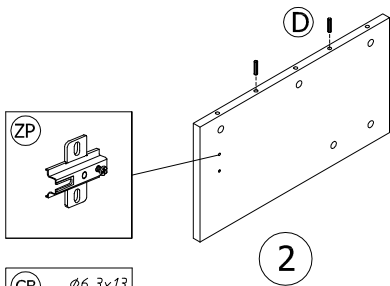
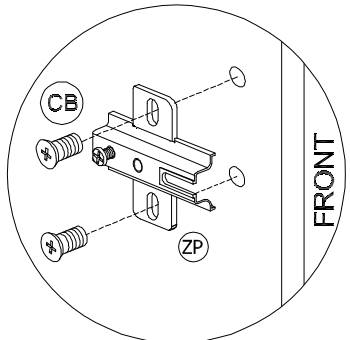
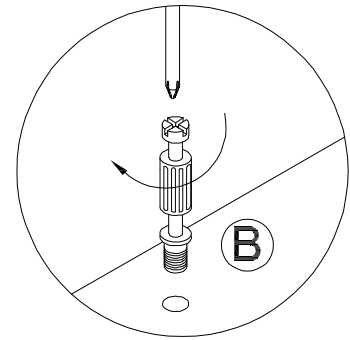
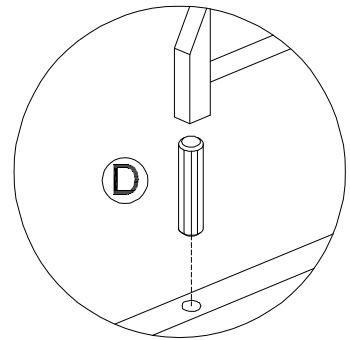
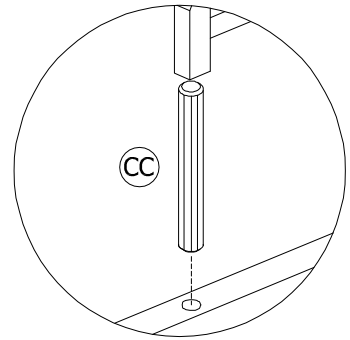
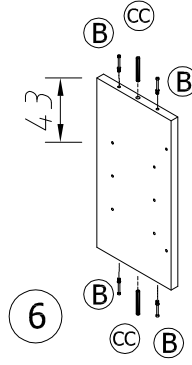
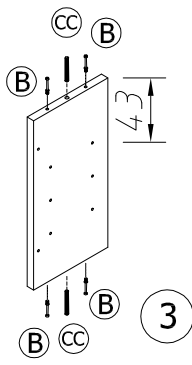

3

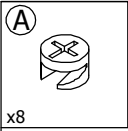

2

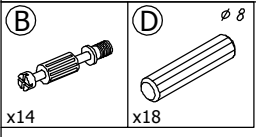
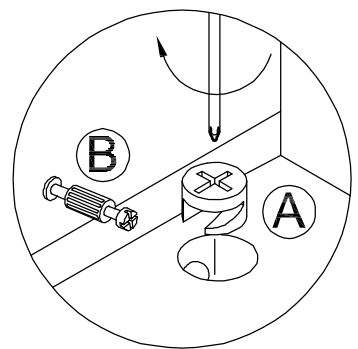
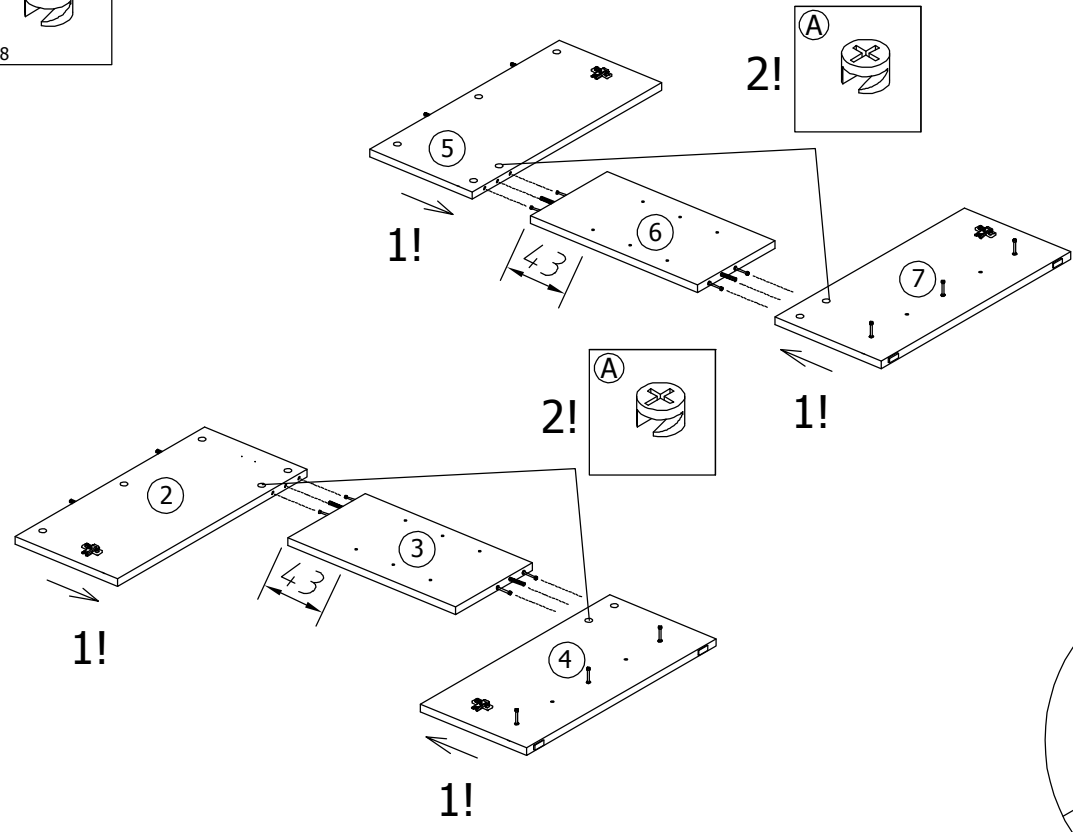

3

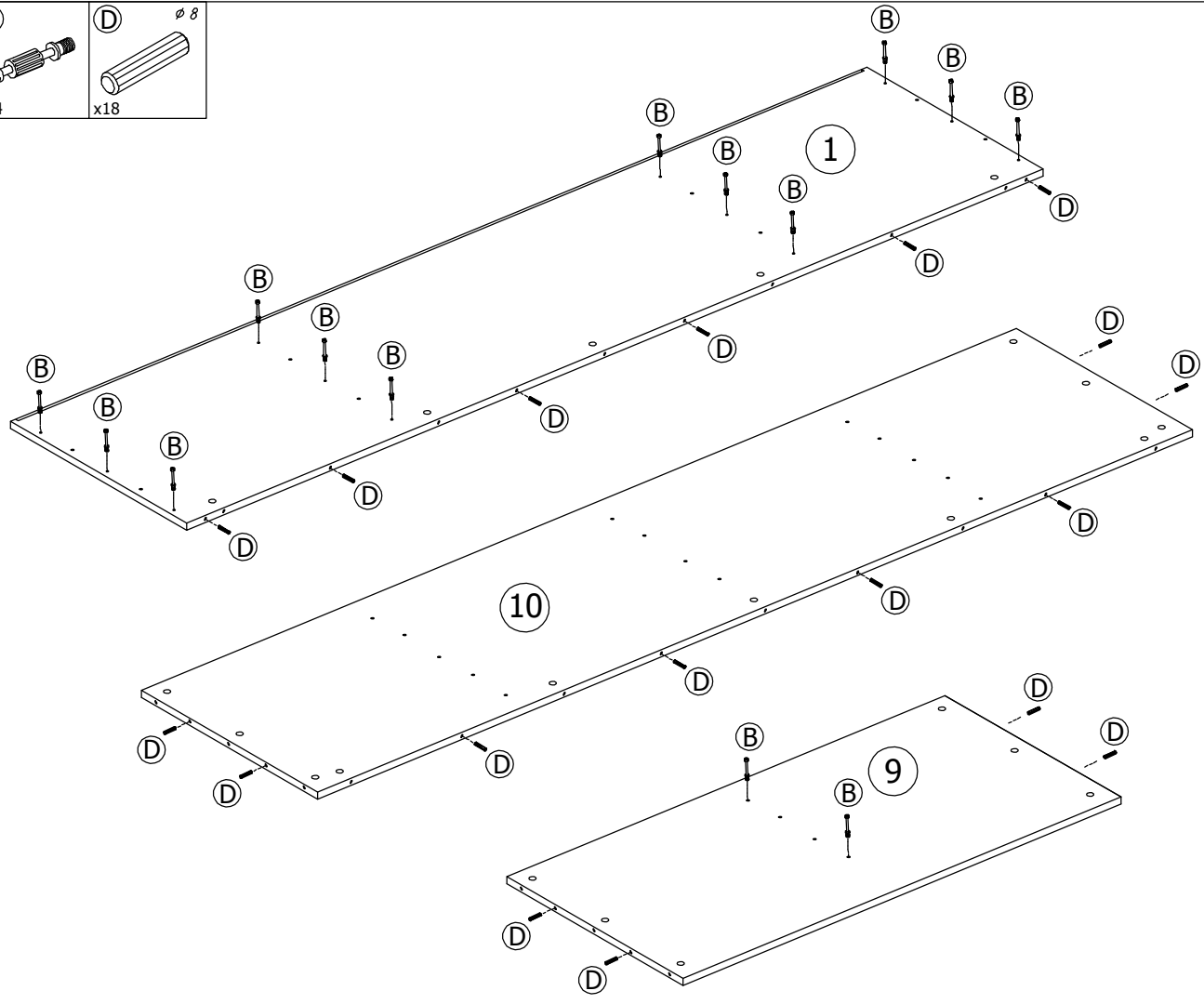

4

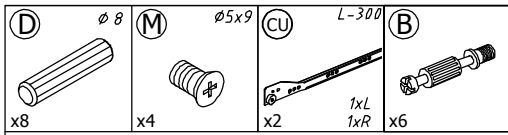

4

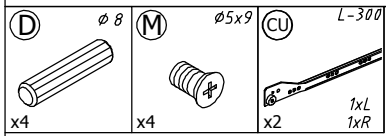
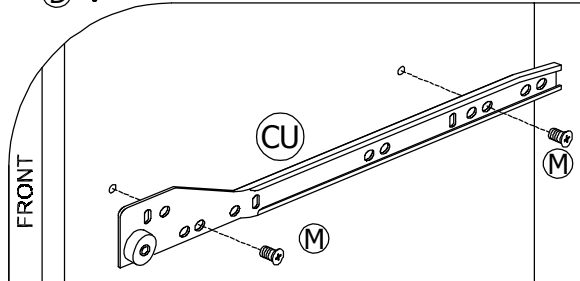
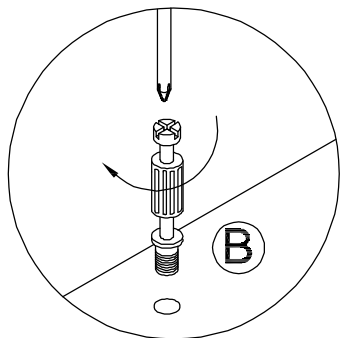
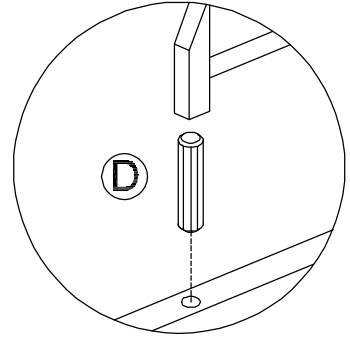
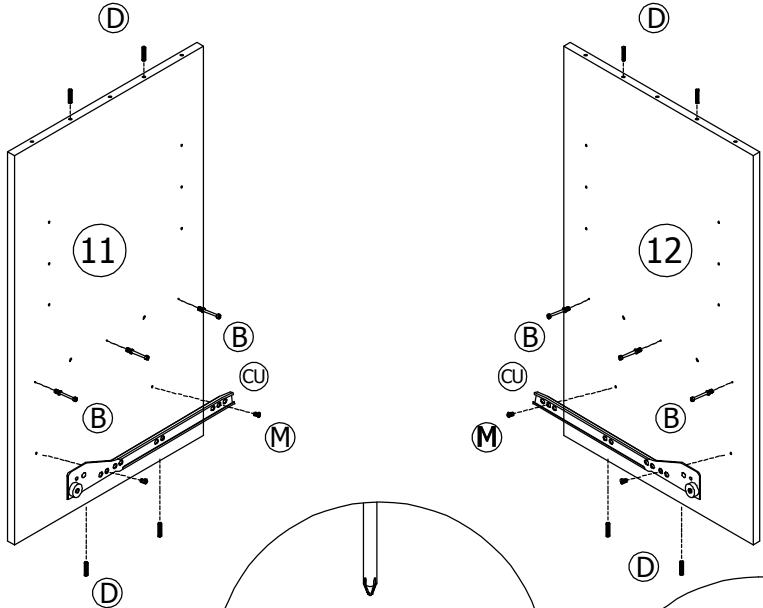

5

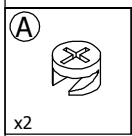
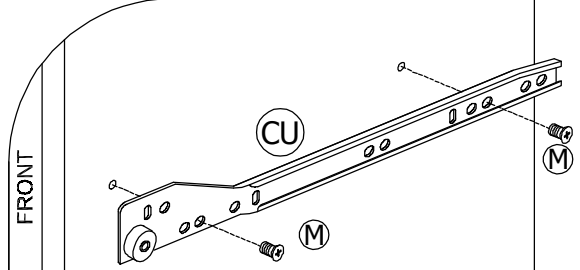
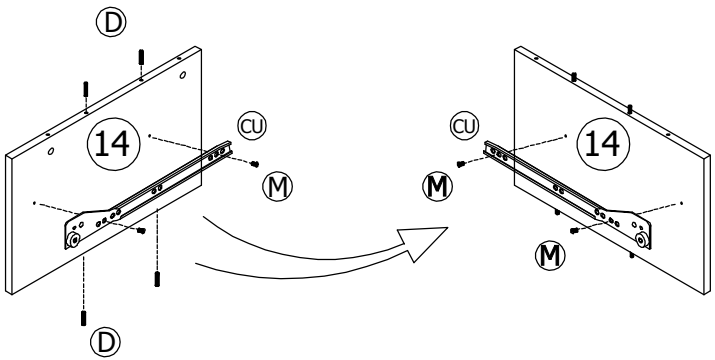

6

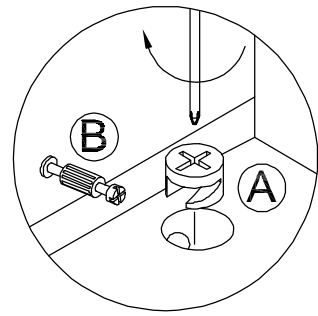
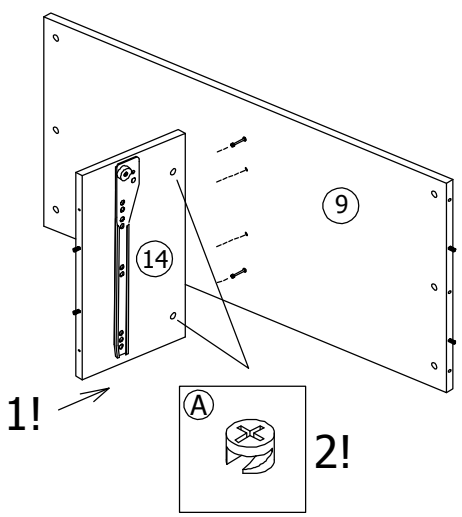

5

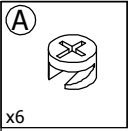

7

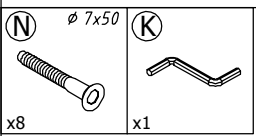
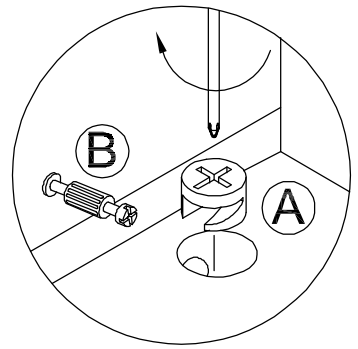
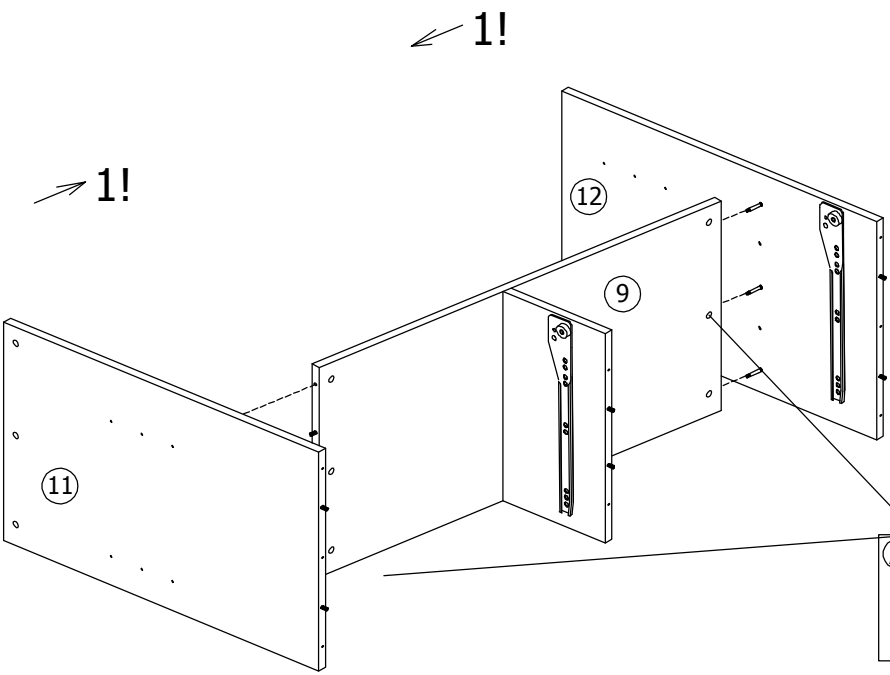

8

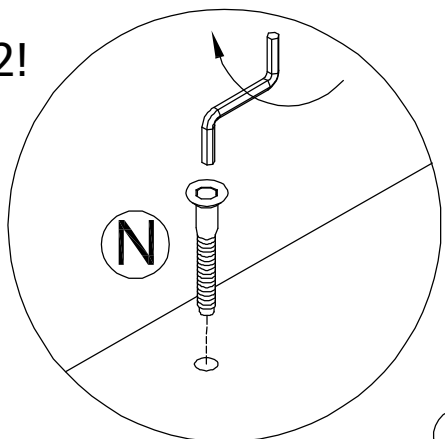
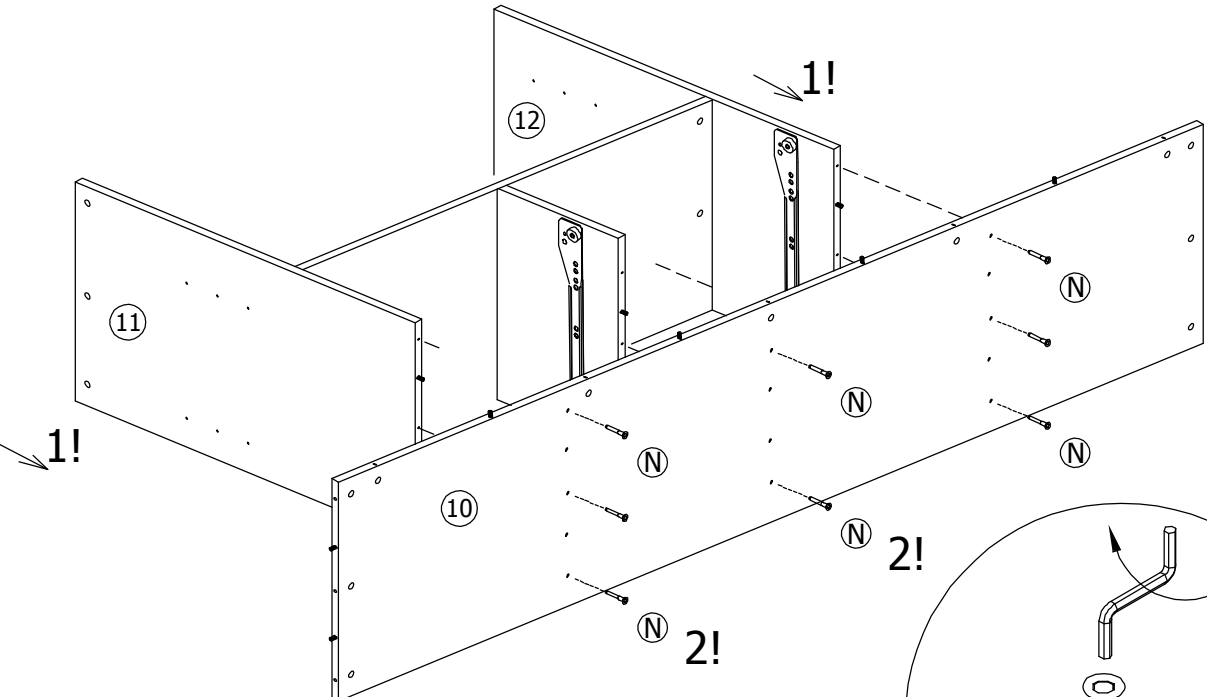

6

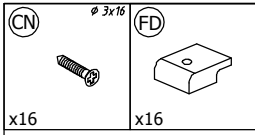

9

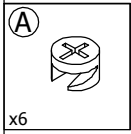
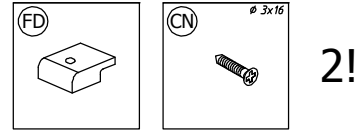
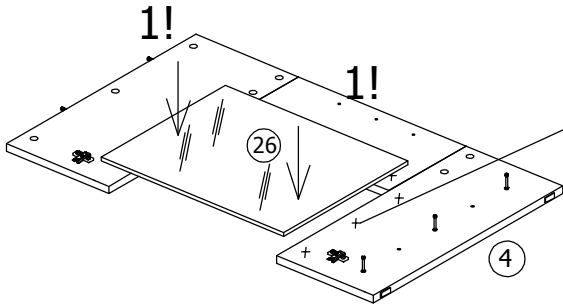
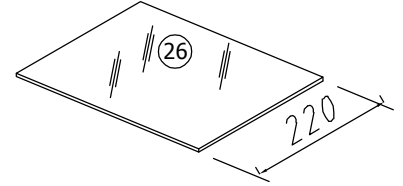
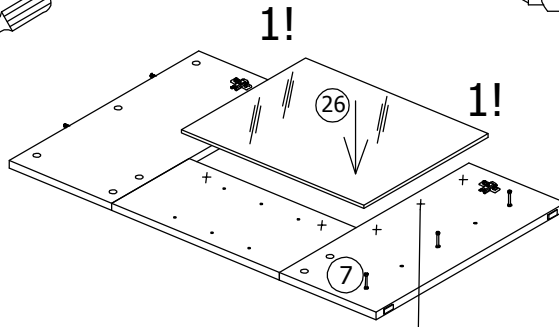
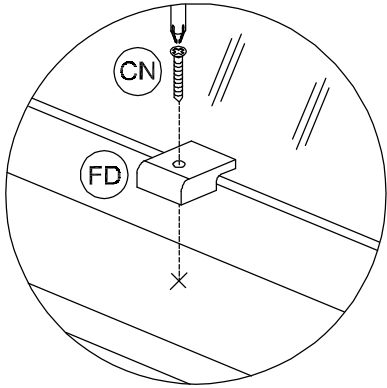
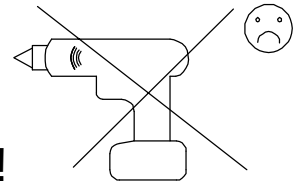
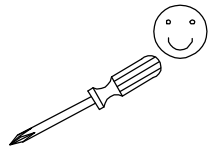

10

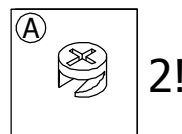
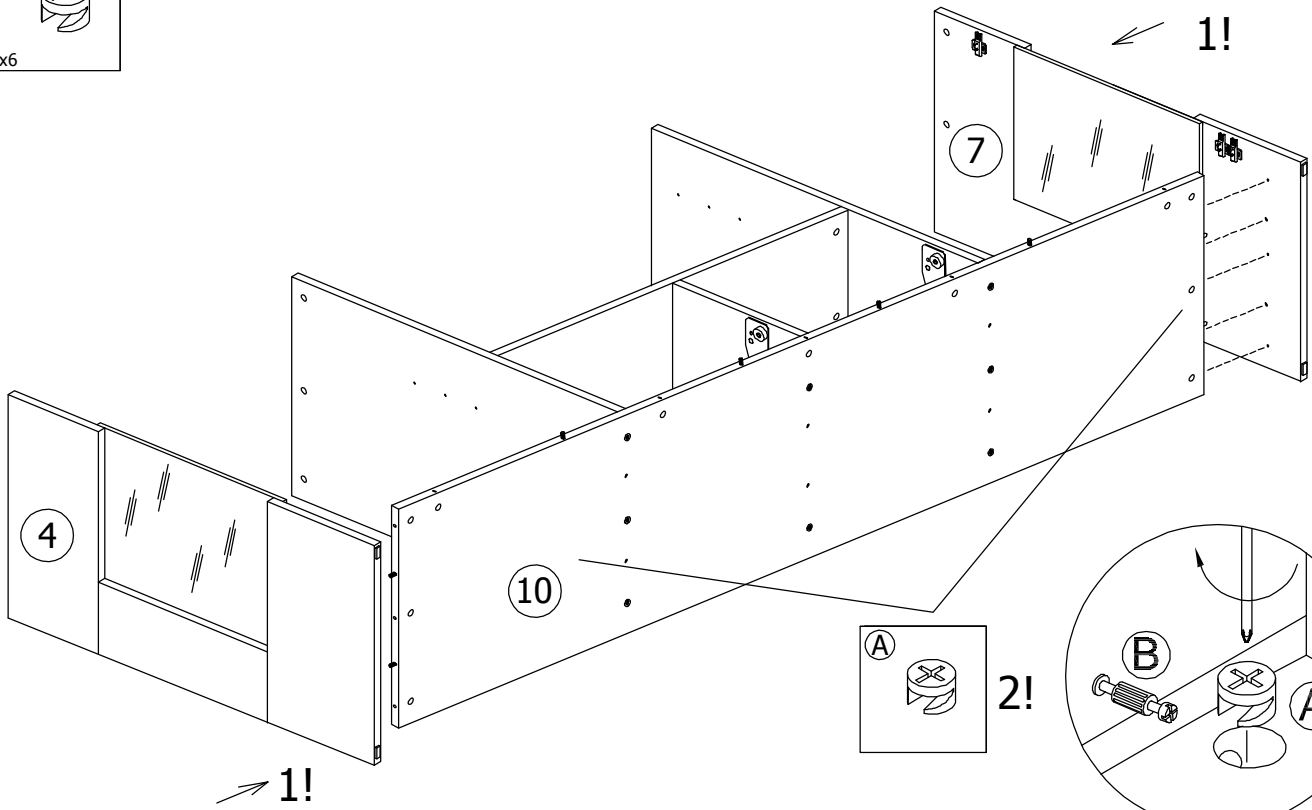

7

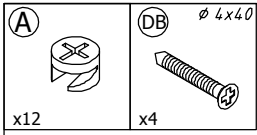

11

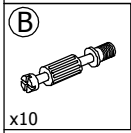
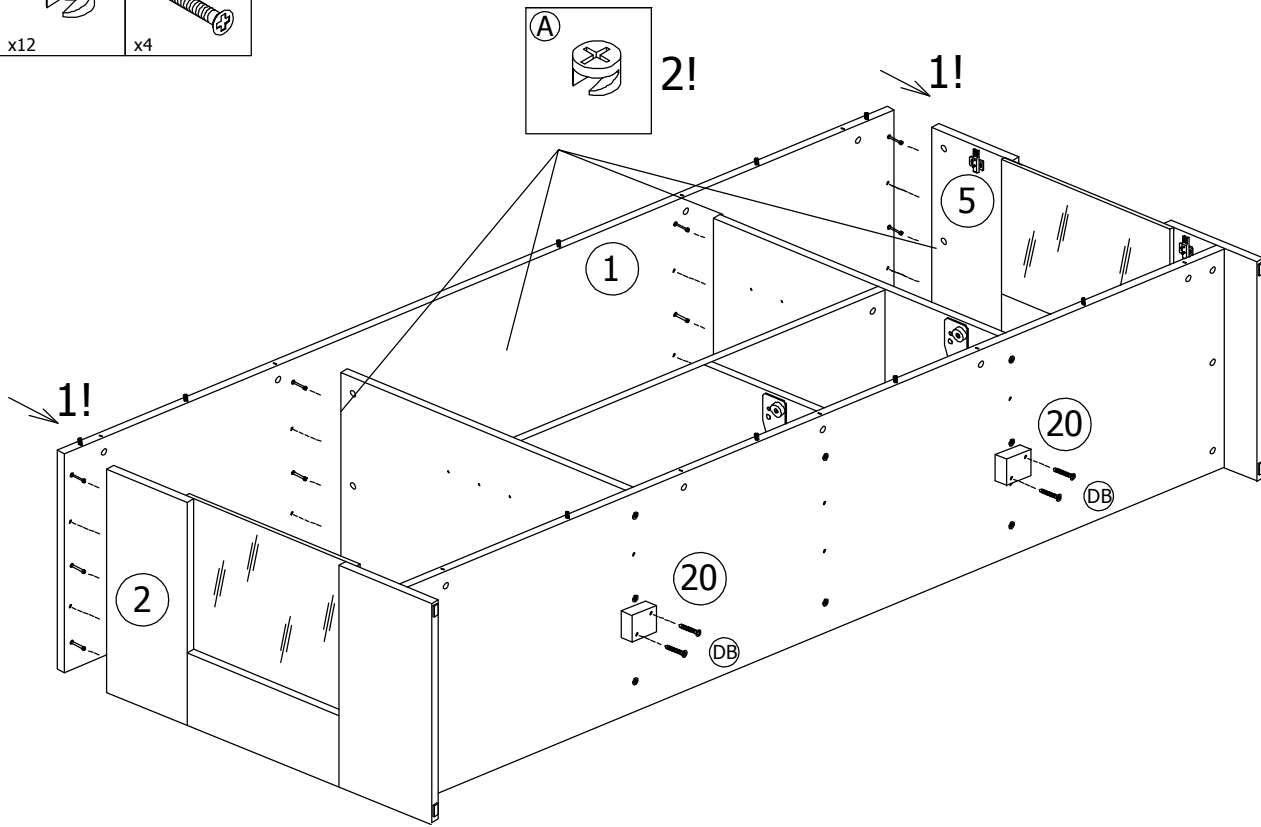

12

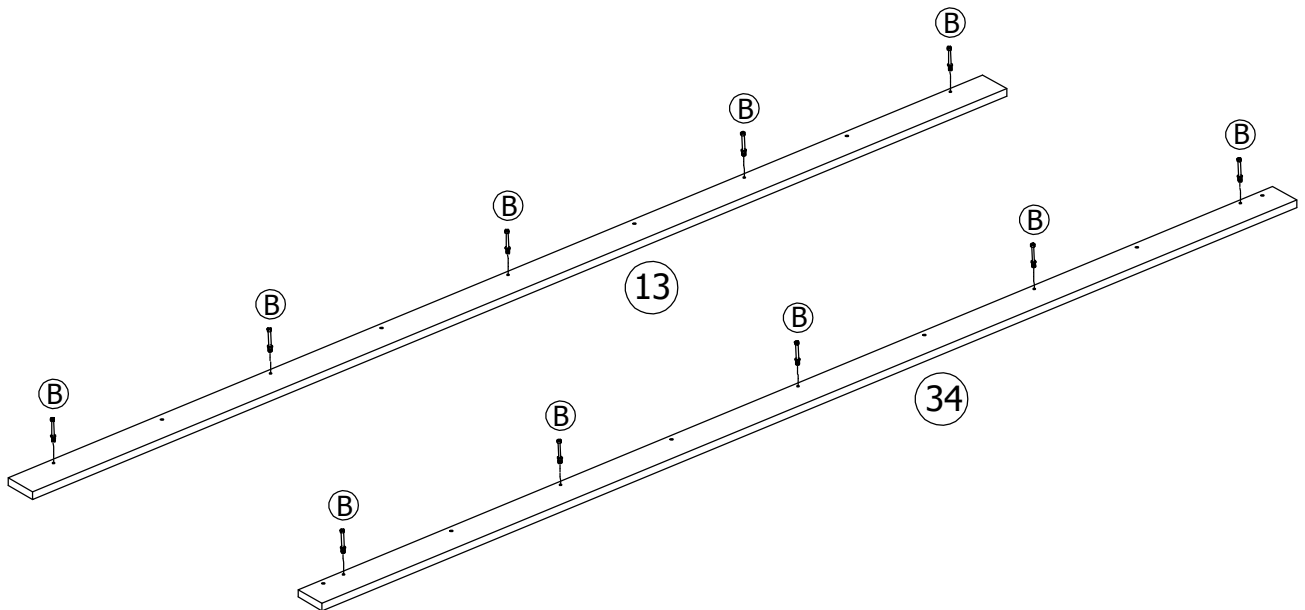

8



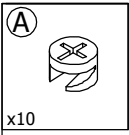

x10

13

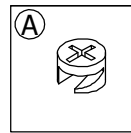
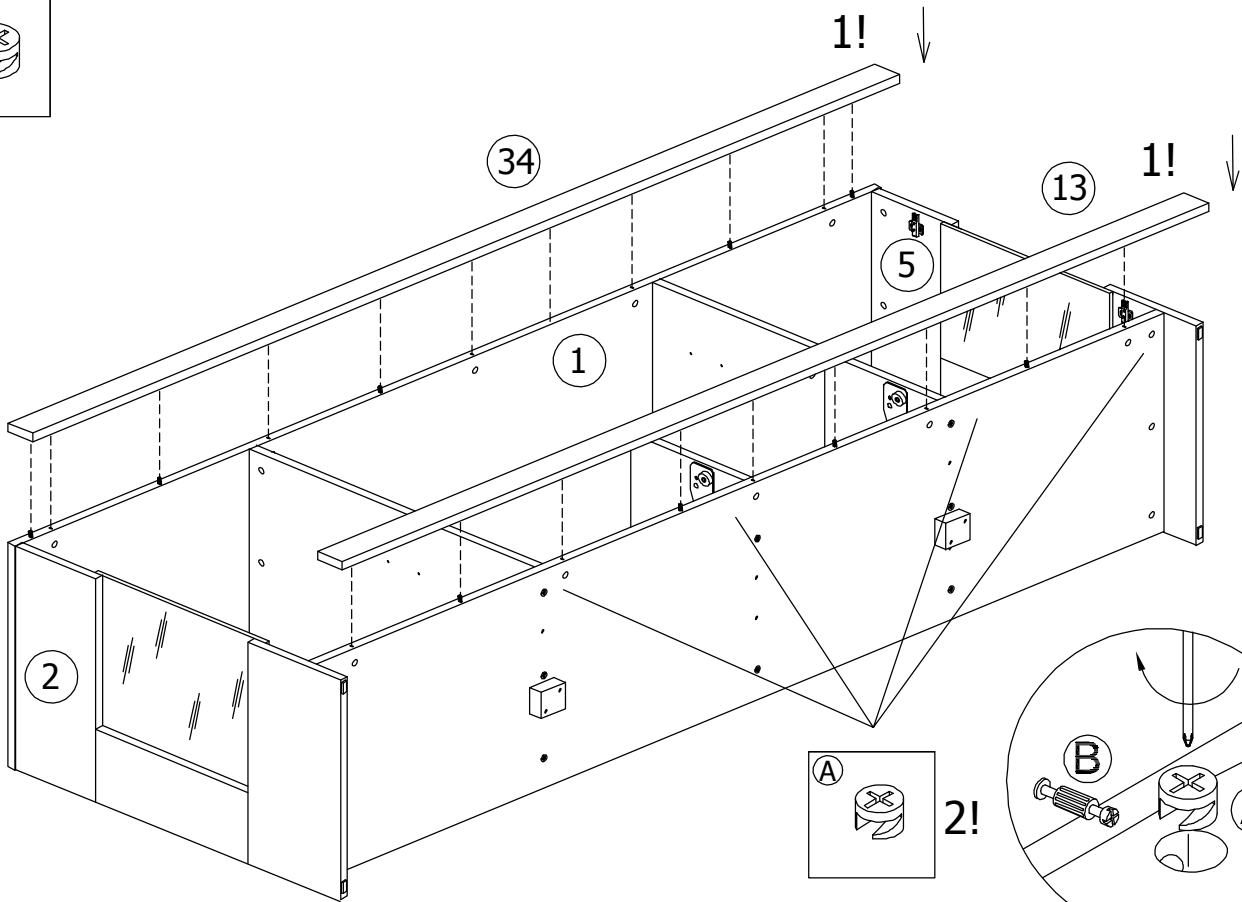

2!

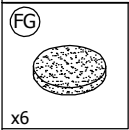
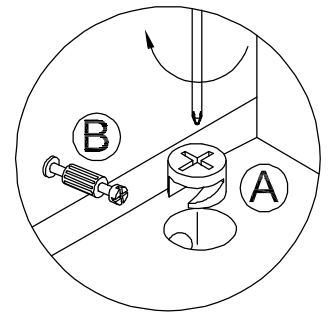

x6

14

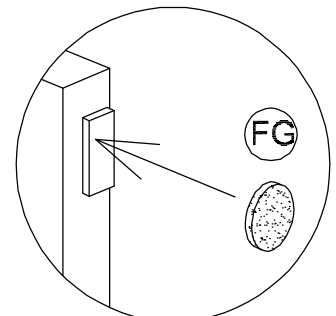
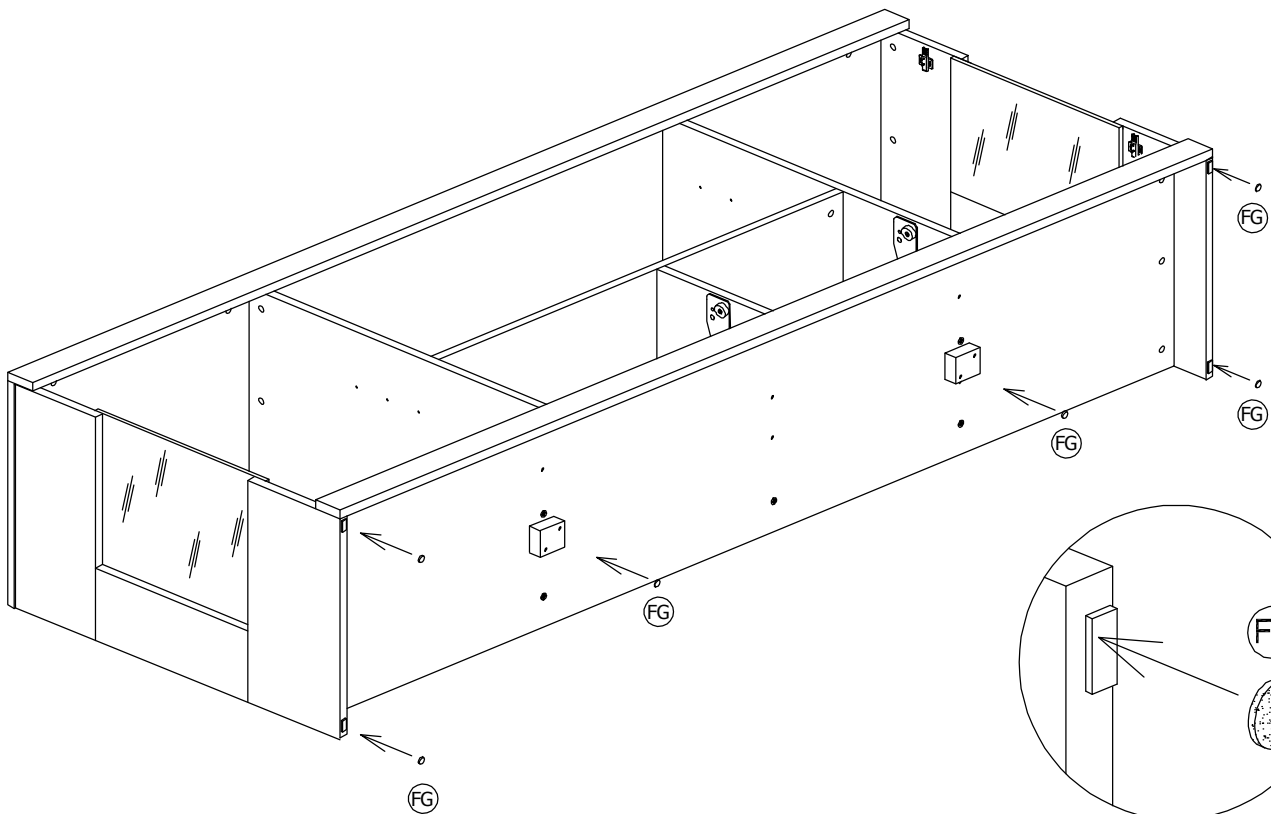

9

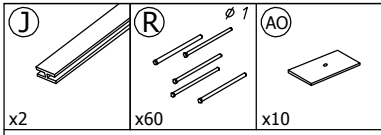

15

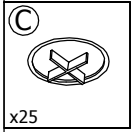
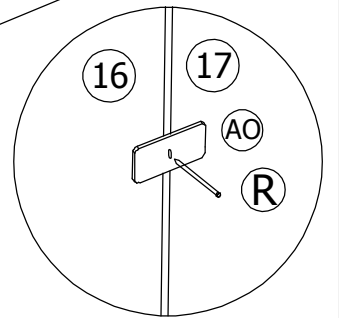
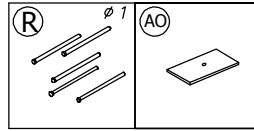
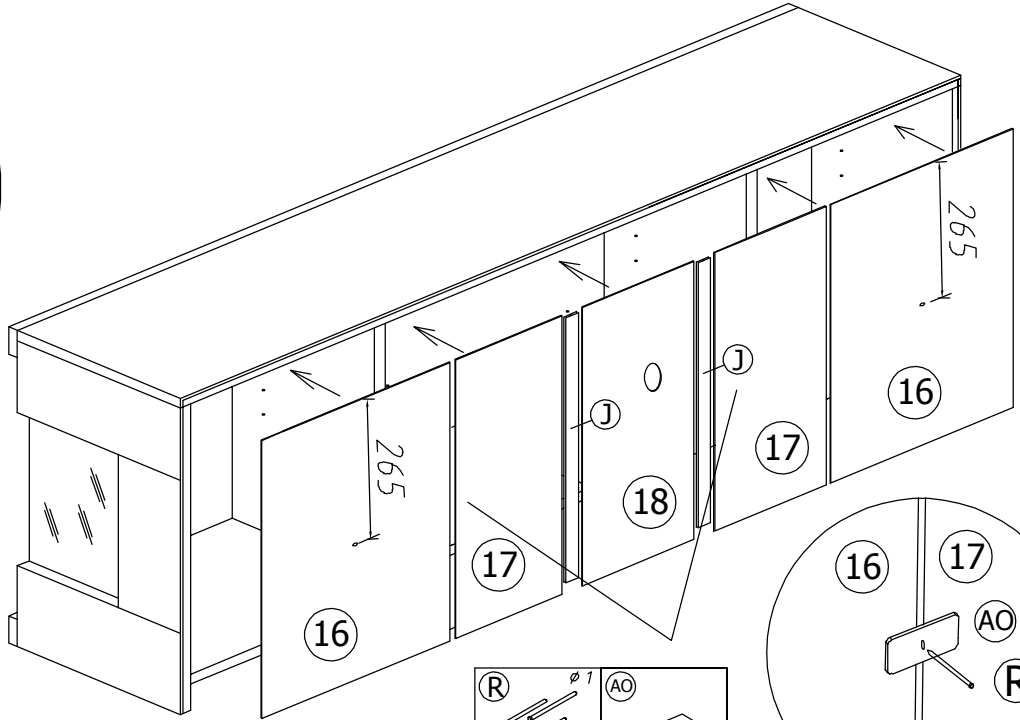
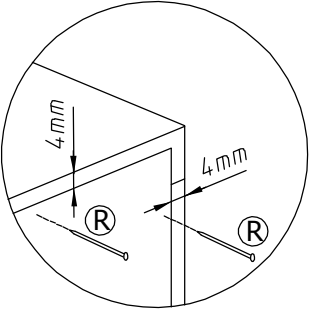
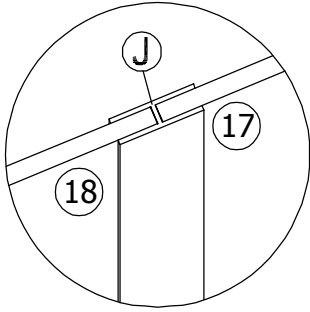

16

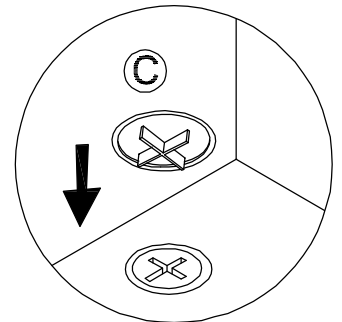
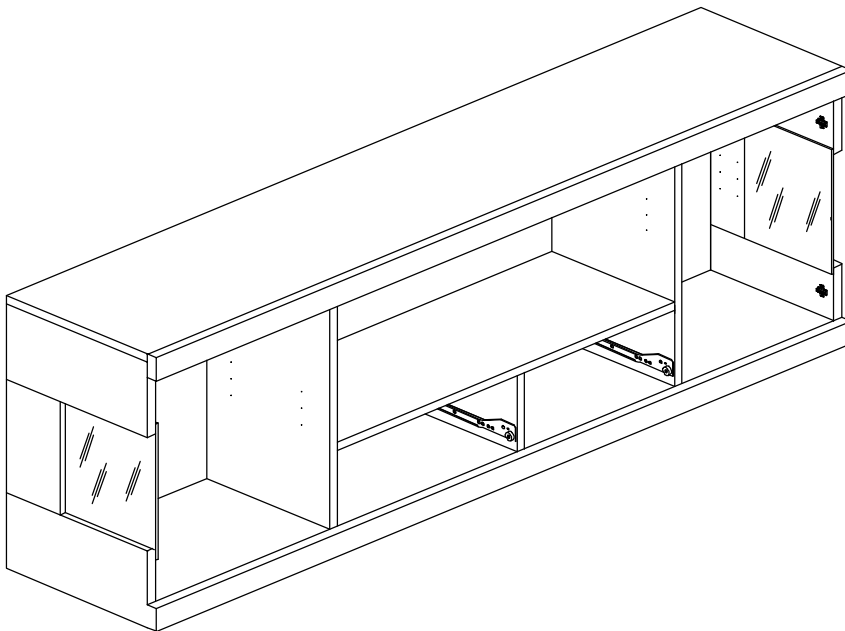

10

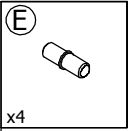

17

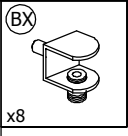
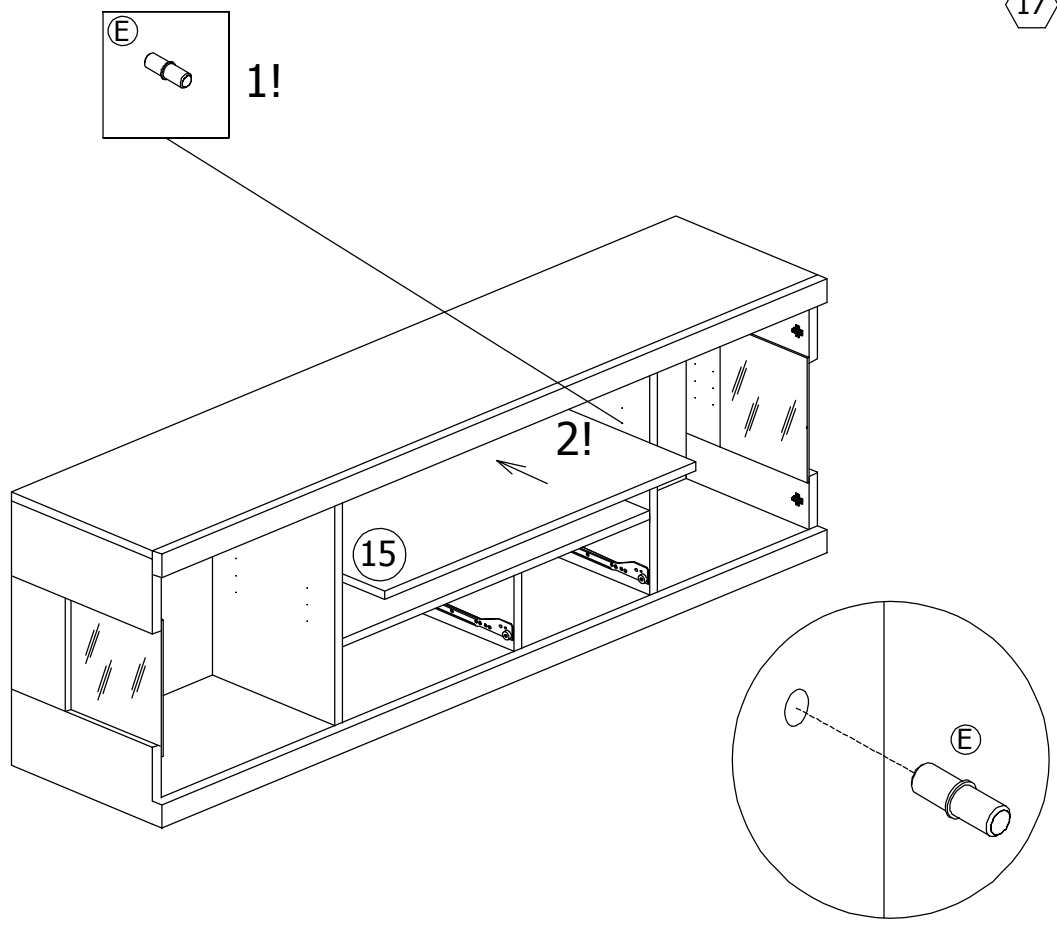

18

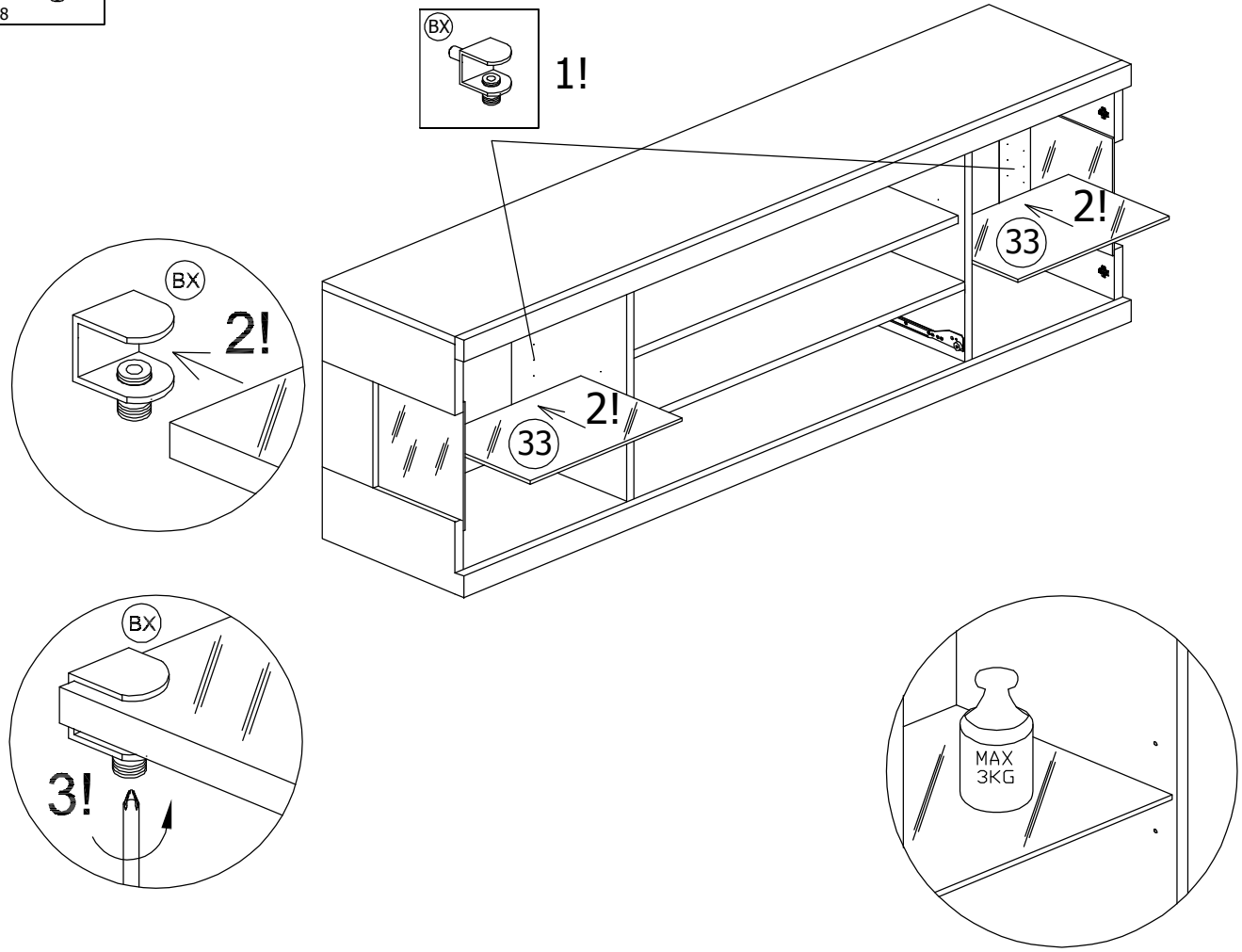

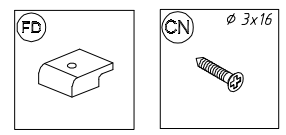
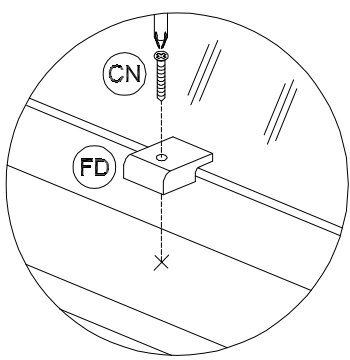
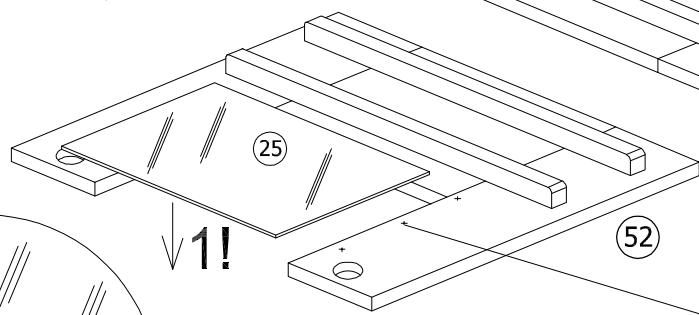
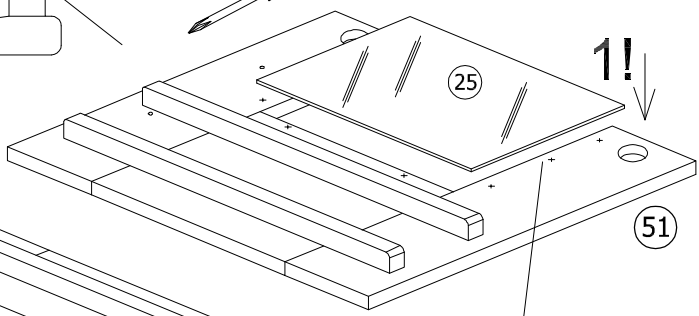
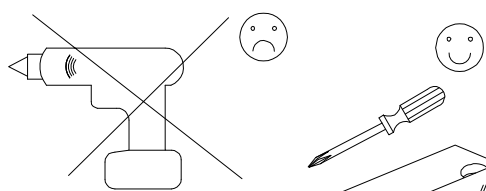
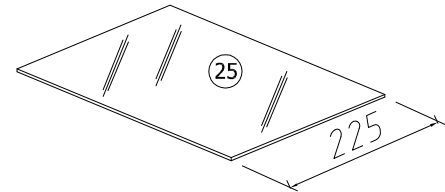
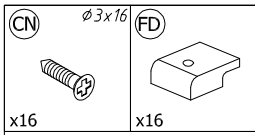

2!

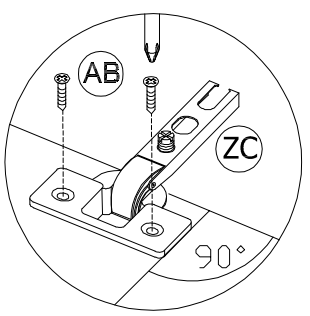
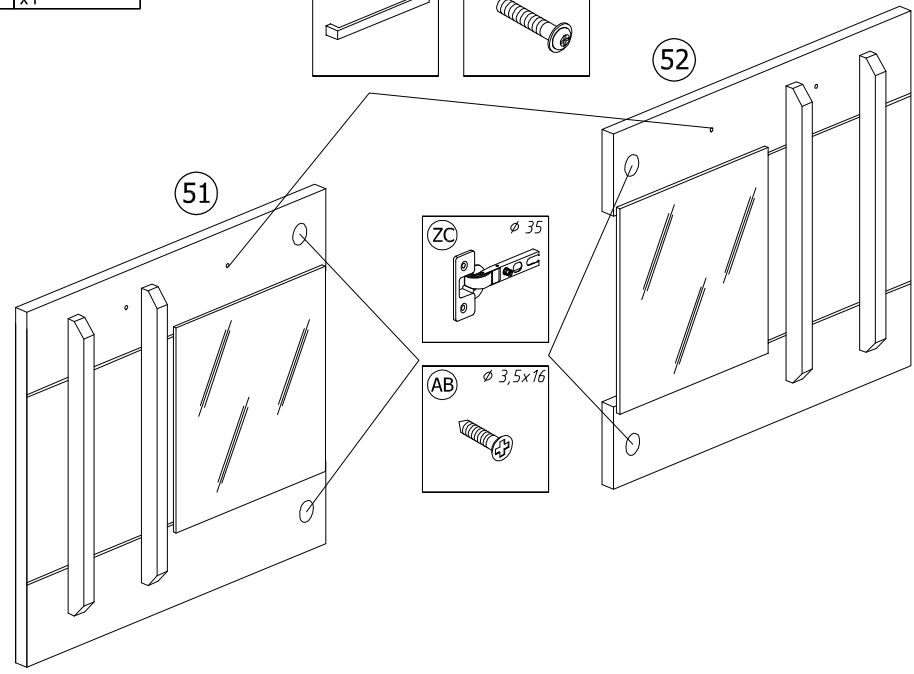
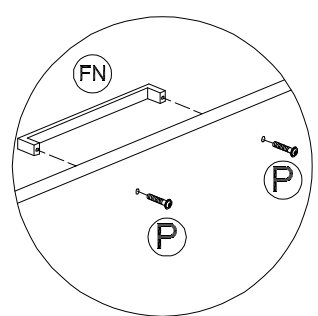
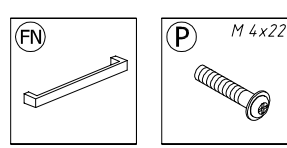
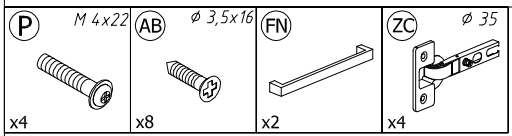

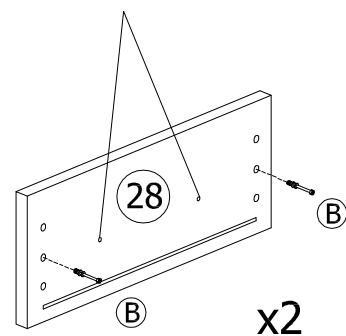
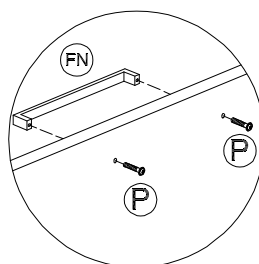
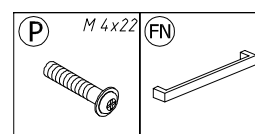
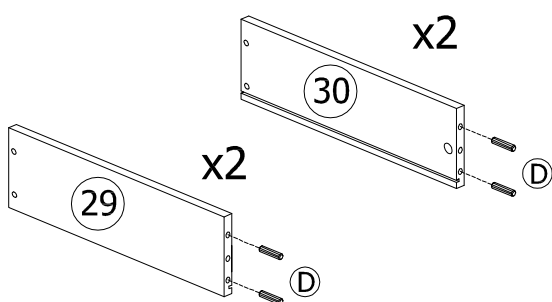
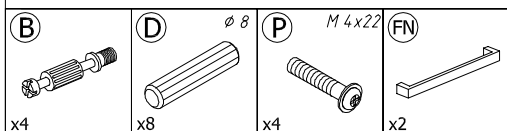
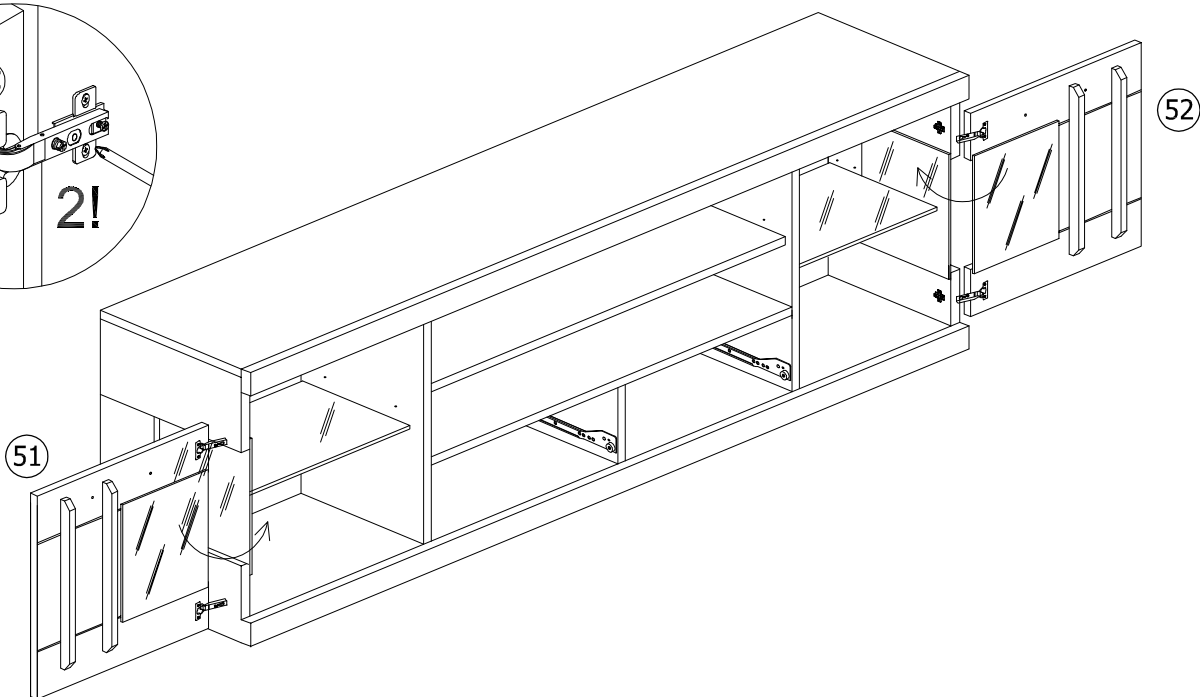
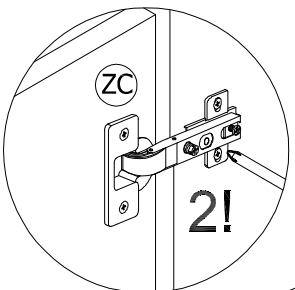
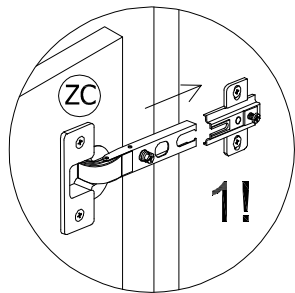

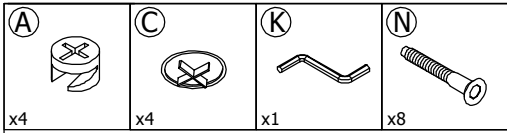

23

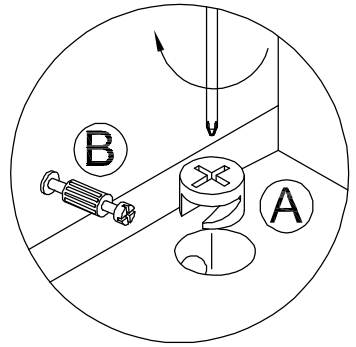
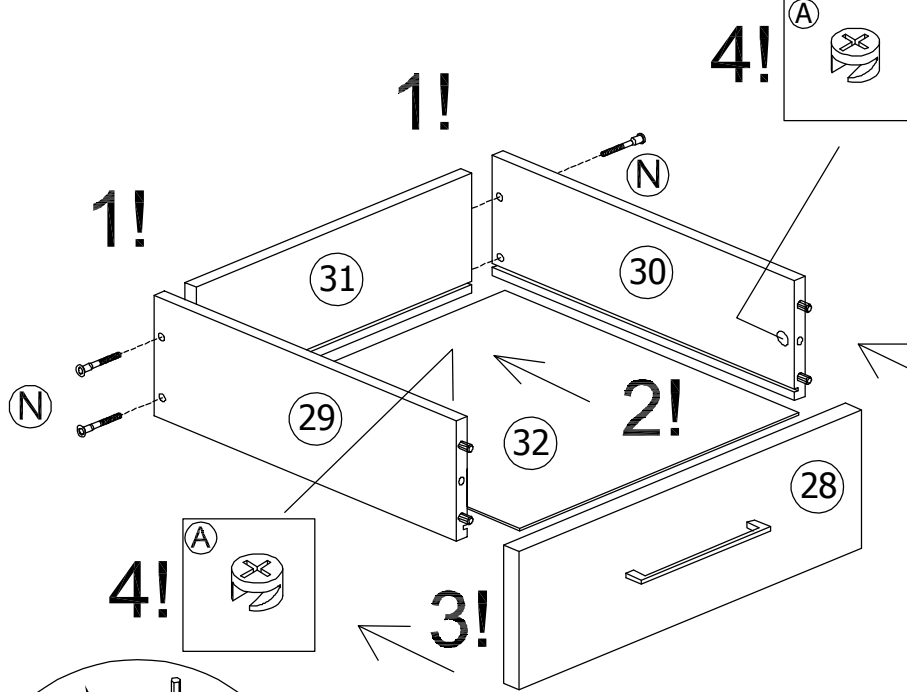

**x2**

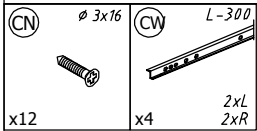
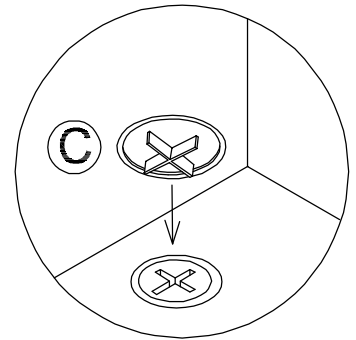
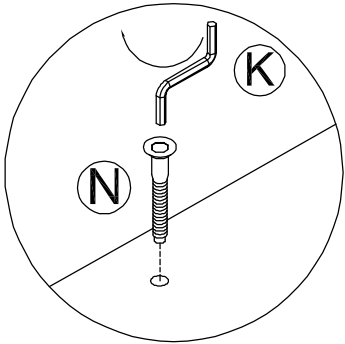

24

**x2**

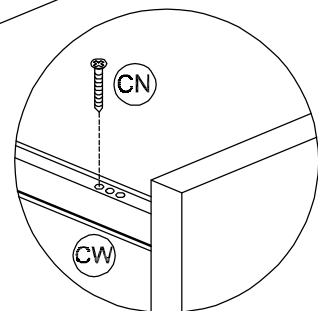
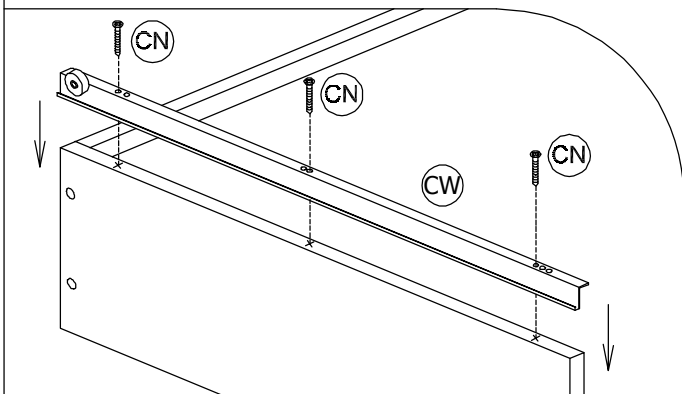
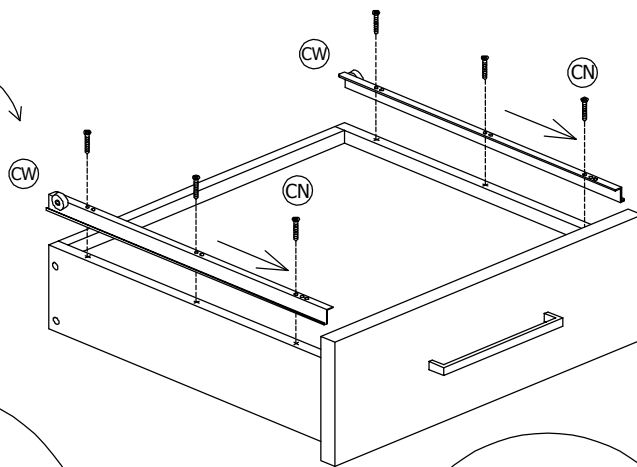
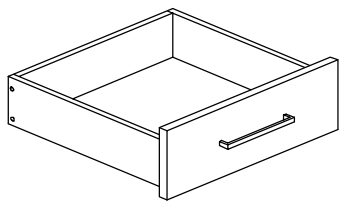

14

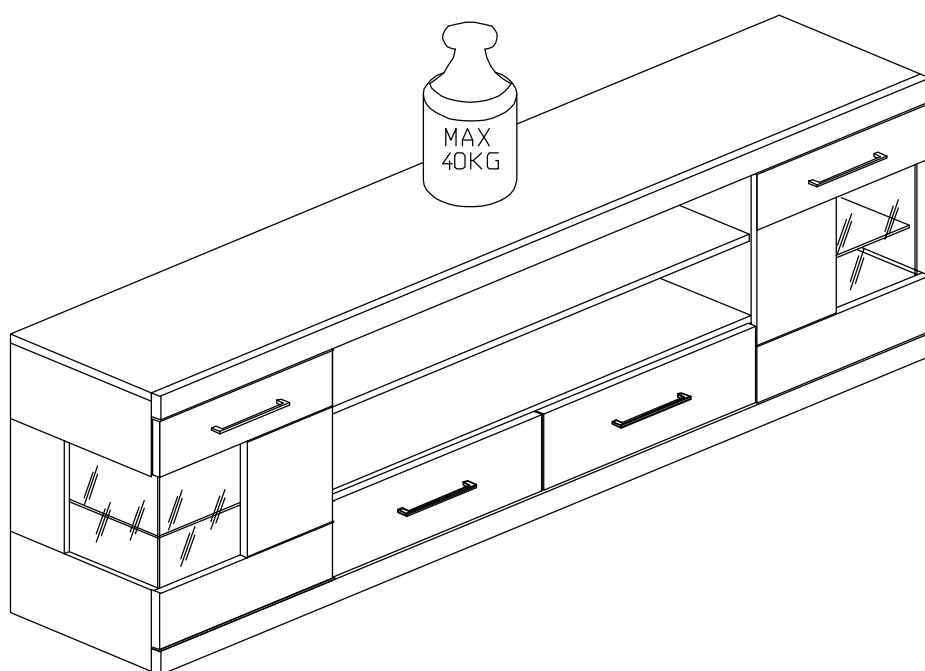
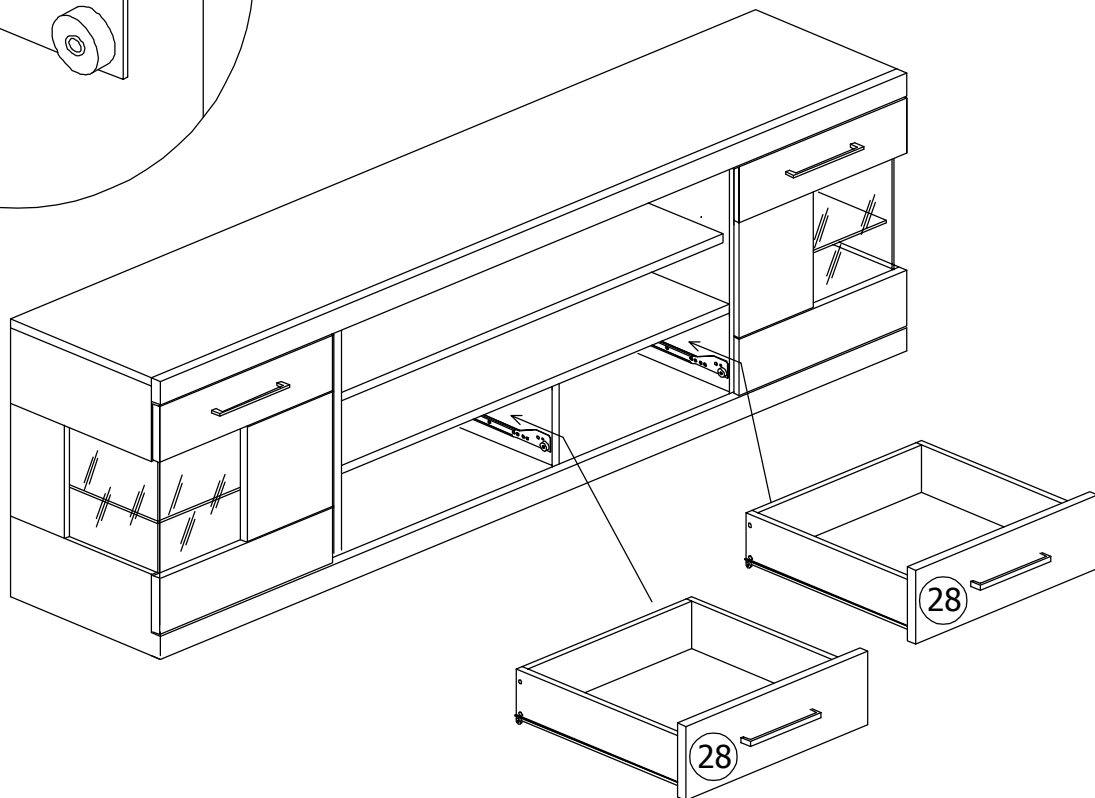
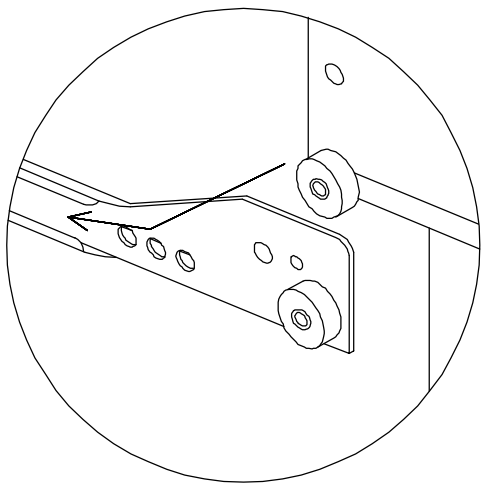

- (D)** Turen einstellen ( Scharniere justieren )
- (GB)** Adjusting the doors ( adjusting the hinges )
- (F)** Mettre la porte ( égaliser les gonds )
- (RO)** Ajustați ușa ( aliniați balamalele )
- (I)** Regolare la porta ( livellare le parentesi )
- (NL)** Deuren instellen ( scharnieren afstellen )
- (PL)** Nastawić drzwi ( wyrównać zawiasy )
- (TR)** Kapıların ayarlanması ( menteşelerin seviye ayarlanması )
- (CZ)** Seřidít dveře ( vyrovnáte závěsy )
- (SK)** Zradíte dvere ( vyrovnajte závesy )
- (HU)** Állítsa be az ajtó ( igazítsa be a zsanérokat )
- (RU)** Регулировка дверей ( регулировка шарнира )

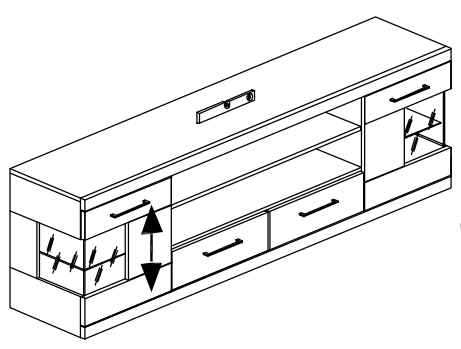

1!

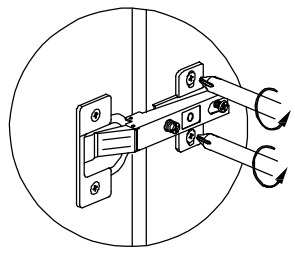

2!

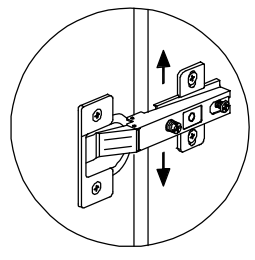

3!

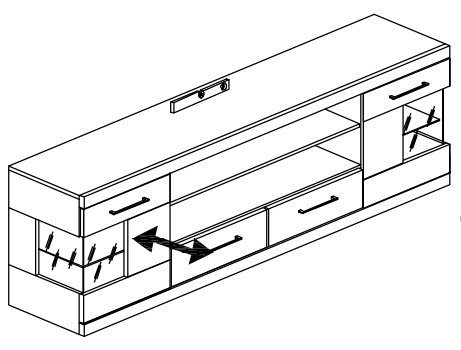
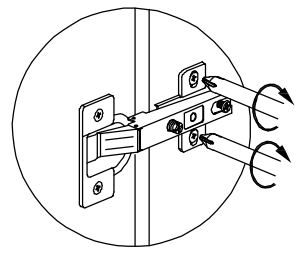

1!

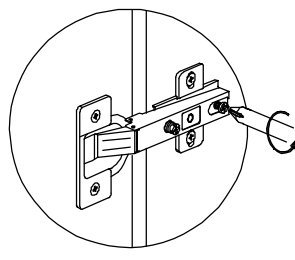

2!

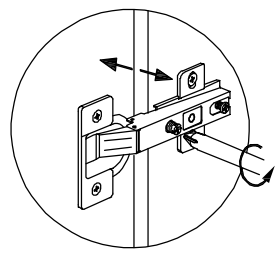

3!

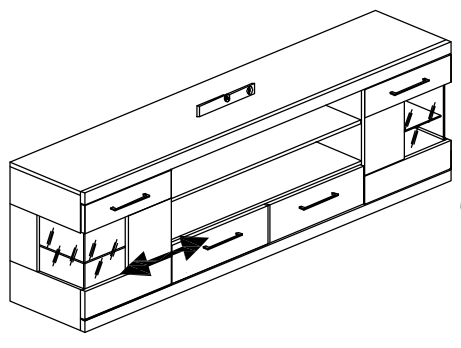
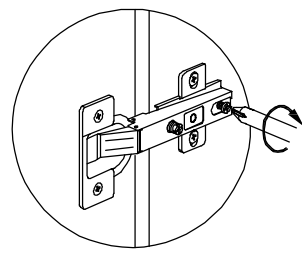

1!

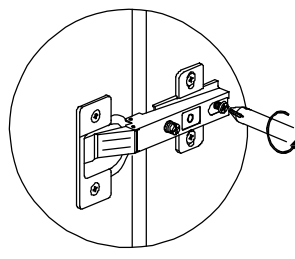

2!

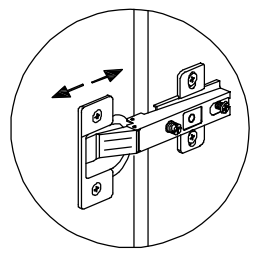

3!

