



MANUFACTURED BY:
Backyard Discovery
 3305 Airport Drive, Pittsburg, KS 66762
 800-856-4445

Basepoint Business Centre: Rivermead Drive, Westlea, Swindon SN5 7EX Phone: 0800-118-2476
 J.P. Coenstraat 7, The Bridge, The Hague, 2595 WP, Netherlands

ATLANTIS

Swing Set

Model # 1608016B



WARNING

Adult Assembly Required.

Not suitable for children under 36 months due to small parts.

FOR DOMESTIC USE ONLY. INTENDED FOR OUTDOOR USE.



Please visit www.backyarddiscovery.com

For the most up to date assembly manual, to register your set, or to order replacement parts
Para obtener instrucciones en español, visite www.backyarddiscovery.com



EASY STEP-BY-STEP
3D INTERACTIVE INSTRUCTIONS

DOWNLOAD THE FREE APP



INSTALLATION
SERVICES
AVAILABLE!
See inside for details

Made in China
 INS-1608016B-ATLANTIS-ENG 08-02-21

Owners Manual - Basic Setup Dimensions & Assembly Notes

Place the set on level ground, not less than 6'-7" [2 m] from any structure or obstruction such as a fence, garage, house, overhanging branches, laundry lines, or electrical wires.

- While assembling unit, take time before and after each phase to make sure fort is level. If fort is not level, assembly will be difficult and improper assembly may result. Extra care must be taken to insure the fort is square.
- The safe play area refers to a zone extending 6'-7" (2 m) beyond the play product on all sides, including the space above the play product.

SAFE PLAY AREA DIAGRAM

Ground Dimension

7'-5 5/8" [2.3 m] x 18'-3 5/8" [5.6 m]

Safe Play Area

20'-7 1/2" [6.3 m] x 31'-5 5/8" [9.6 m] x 15'-11 3/8" [4.9 m]

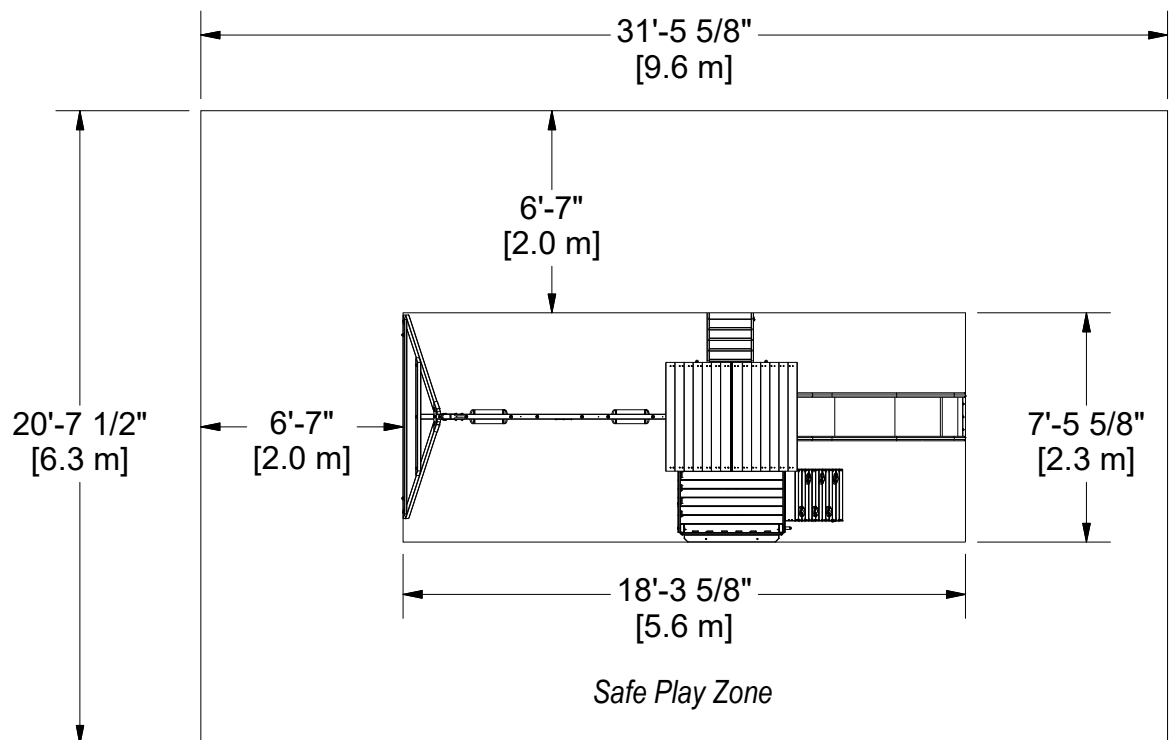

SAFE PLAY HEIGHT: 15'-11 3/8 [4.9 m]
MAXIMUM FALL HEIGHT: 6'-5 3/8" [2.0 m]

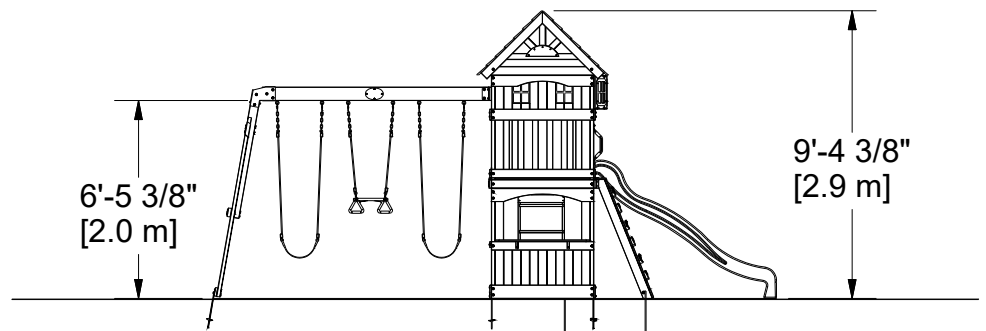

General Information:

Your set has been designed and engineered for children only and for residential use only. A maximum of 150 lbs. per child is recommended for play activities designed for individual use. A maximum of 120 lbs. per child is recommended for play activities designed for multiple child use. A maximum of 9 children is recommended for this swing set.

Owners Manual - Parts Identification

Wood Components (Not to Scale)

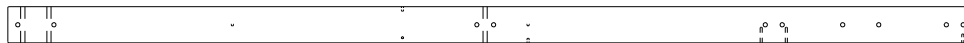

E1 | TOWER LEG - W4L16280
(x1) | 1 3/8"x3 3/8"x90 1/2" (36x86x2298)

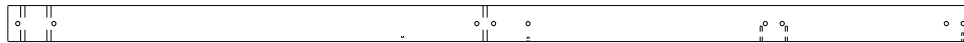

E2 | TOWER LEG - W4L16279
(x1) | 1 3/8"x3 3/8"x90 1/2" (36x86x2298)

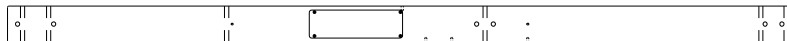

E3 | TOWER LEG W/TAG - W2A03400
(x1) | 1 3/8"x3 3/8"x74" (36x86x1880)



E6 | TOWER LEG - W4L16278
(x1) | 1 3/8"x3 3/8"x74" (36x86x1880)

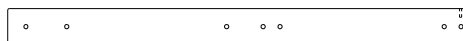

E4 | CLUB HOUSE LEG - W102883
(x1) | 1 3/8"x3 3/8"x43 3/8" (36x86x1102)



E5 | CLUB HOUSE LEG - W102882
(x1) | 1 3/8"x3 3/8"x43 3/8" (36x86x1102)



E30 | ROCKWALL RAIL - W4L16273
(x2) | 1 3/8"x3 3/8"x48 3/4" (36x86x1239)

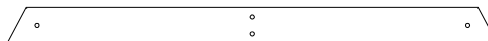

E50 | END SUPPORT - W4L14651
(x1) | 1 1/2"x3 1/2"x46" (36x86x1168)



E77 | ANGLE BRACE - W4L14652
(x2) | 1 3/8"x3 3/8"x81" (36x86x2056)

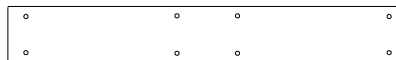

G1 | SWING BEAM MOUNT - W102365
(x1) | 1"x5 1/4"x37 3/8" (24x134x950)



H1 | LEFT FLOOR RAIL - W100557
(x1) | 1"x3 3/8"x63 7/8" (24x86x1624)



H2 | RIGHT FLOOR RAIL - W4L16276
(x1) | 1"x3 3/8"x63 7/8" (24x86x1624)



H3 | ROOF RAFTER - W100559
(x4) | 1"x3 3/8"x34" (24x86x864)

Owners Manual - Parts Identification

Wood Components (Not to Scale)

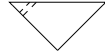

H4 | TABLE SUPPORT - W100560
(x2) | 1"x2"x4" (24x51x102)



H5 | FLOOR SUPPORT - W100598
(x4) | 1"x3 3/8"x3 3/8" (24x86x86)

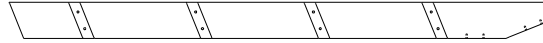

H6 | LEFT UPRIGHT - W4L16265
(x1) | 1"x3 3/8"x50 3/4" (24x86x1290)



H7 | RIGHT UPRIGHT - W4L16266
(x1) | 1"x3 3/8"x50 3/4" (24x86x1290)



H80 | GROUND BOARD - W4L14653
(x1) | 1"x3 3/8"x79 1/2" (24x86x2018)



J1 | DECK BRACE - W100561
(x4) | 1"x2 3/8"x15 3/4" (24x60x400)



J2 | ATTACHMENT BOARD - W4L16268
(x1) | 1"x3 3/8"x20 1/4" (24x86x514)



K1 | BASE BOARD - W100562
(x2) | 5/8"x5 1/4"x63 7/8" (16x134x1624)



K2 | BASE BOARD - W100563
(x2) | 5/8"x5 1/4"x40" (16x134x1016)



K3 | FRONT ARCH - W100564
(x1) | 5/8"x5 1/4"x40" (16x134x1016)

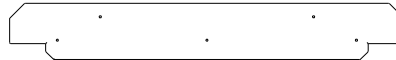

K4 | TABLE TOP - W100565
(x1) | 5/8"x5 1/4"x37" (16x134x940)



L1 | LEFT WALL RAIL - W102360
(x1) | 5/8"x4 3/8"x63 7/8" (16x112x1624)



L2 | RIGHT WALL RAIL - W100567
(x1) | 5/8"x4 3/8"x63 7/8" (16x112x1624)

Owners Manual - Parts Identification

Wood Components (Not to Scale)



L3 | WALL RAIL - W100568
(x1) | 5/8"x4 3/8"x40" (16x112x1016)



L5 | FLOOR BOARD - W100570
(x2) | 5/8"x4 3/8"x37 1/8" (16x112x942)

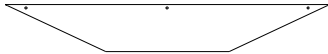

L6 | BAY WINDOW HEADER - W100571
(x2) | 5/8"x4 3/8"x30 1/2" (16x112x774)

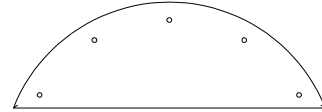

L7 | GABLE MOON - W100572
(x2) | 5/8"x4 3/8"x13" (16x112x330)

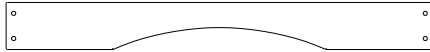

L8 | CLUB HOUSE WALL RAIL - W100569
(x2) | 5/8"x4 3/8"x40" (16x112x1016)



M1 | WALL RAIL - W100573
(x1) | 5/8"x3 3/8"x63 7/8" (16x86x1624)

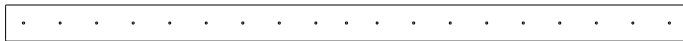

M2 | FLOOR RUNNER - W100574
(x1) | 5/8"x3 3/8"x63 7/8" (16x86x1624)



M3 | FLOOR BOARD - W100575
(x16) | 5/8"x3 3/8"x41 7/8" (16x86x1064)



M4 | WALL BOARD - W100576
(x11) | 5/8"x3 3/8"x42" (16x86x1066)



M5 | WALL BOARD - W100577
(x4) | 5/8"x3 3/8"x42" (16x86x1066)



M6 | FLOOR RAIL - W4L16267
(x1) | 5/8"x3 3/8"x40" (16x86x1016)



M7 | WALL BOARD - W100579
(x2) | 5/8"x3 3/8"x40" (16x86x1016)



M8 | WALL RAIL - W100580
(x3) | 5/8"x3 3/8"x40" (16x86x1016)



M9 | WALL RAIL - W100581
(x2) | 5/8"x3 3/8"x37 1/2" (16x86x951)



M10 | WALL BOARD - W100582
(x2) | 5/8"x3 3/8"x25" (16x86x634)



M11 | WALL BOARD - W100583
(x9) | 5/8"x3 3/8"x20" (16x86x508)



M12 | WALL BOARD - W100584
(x3) | 5/8"x3 3/8"x16 7/8" (16x86x428)



M13 | WALL RAIL - W100585
(x4) | 5/8"x3 3/8"x8 1/4" (16x86x208)



M14 | WALL RAIL - W100586
(x2) | 5/8"x3 3/8"x6 3/4" (16x86x172)



M15 | WALL BOARD - W100587
(x8) | 5/8"x3 3/8"x4 1/8" (16x86x106)



M16 | WALL BOARD - W100599
(x2) | 5/8"x3 3/8"x42" (16x86x1066)



M17 | WALL RAIL - W102881
(x2) | 5/8"x3 3/8"x40" (16x86x1016)



M18 | LADDER RUNG - W4L16262
(x4) | 1"x3 3/8"x17 1/8" (24x86x434)



M19 | ATTACHMENT BOARD - W4L16263
(x1) | 5/8"x3 3/8"x18 1/4" (16x86x462)



M20 | REAR SUPPORT - W4L16264
(x1) | 5/8"x3 3/8"x18 1/4" (16x86x462)

Owners Manual - Parts Identification

Wood Components (Not to Scale)



M26 | ROCK WALL BOARD - W4L16272
(x8) | 5/8"x3 3/8"x23 1/4" (16x86x590)



M29 | ROCK WALL BOARD - W4L16270
(x6) | 5/8"x3 1/2"x20 1/4" (16x90x514)



M30 | ROCK WALL END BOARD - W4L16269
(x1) | 5/8"x3 7/8"x20 1/4" (16x100x514)



M77 | SLIDE BRACE - W100544
(x1) | 5/8"x3 3/8"x17 1/4" (16x86x438)



M78 | CENTER SLIDE BRACE - W100545
(x2) | 5/8"x3 3/8"x17 1/4" (16x86x438)



N1 | SWING BLOCK - W100588
(x1) | 5/8"x2 3/8"x63 7/8" (16x60x1624)



N2 | FLOOR BOARD - W100589
(x1) | 5/8"x2 3/8"x41 7/8" (16x60x1064)



N3 | GABLE BOARD - W100590
(x2) | 5/8"x2 3/8"x31 1/2" (16x60x800)



N4 | WALL BOARD - W100591
(x10) | 5/8"x2 3/8"x23" (16x60x584)

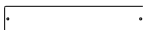

N5 | BAY WINDOW BOARD - W100592
(x6) | 5/8"x2 3/8"x13 1/8" (16x60x332)

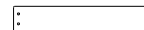

N6 | GABLE BOARD - W100593
(x2) | 5/8"x2 3/8"x13" (16x60x330)



N7 | GABLE BOARD - W100594
(x4) | 5/8"x2 3/8"x8" (16x60x202)



N8 | WALL BOARD SUPPORT - W100595
(x2) | 5/8"x2 3/8"x6 3/4" (16x60x170)



N9 | BAY WINDOW BOARD - W100596
(x6) | 5/8"x2 3/8"x6 1/4" (16x60x158)

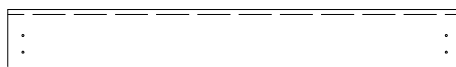

R1 | ROOF BOARD - W100597
(x14) | 3/4"x5 1/2"x42 1/2" (18x140x1080)



SB74 | SWING BEAM EXTENDED - W4L14650
(x1) | 2"x5 1/4"x89 1/2" (50x134x2274)

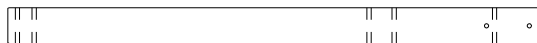

W71 | SWING BEAM SUPPORT - W4L14654
(x1) | 2"x3 3/8"x50 3/8" (50x86x1280)

Owners Manual - Parts Identification

Hardware Components

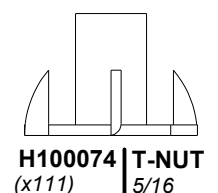
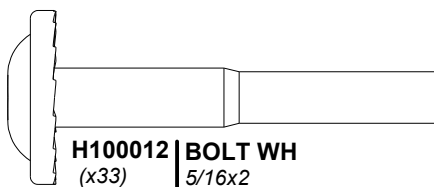
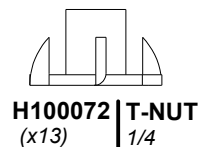
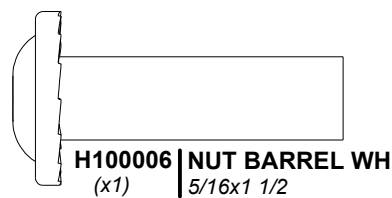
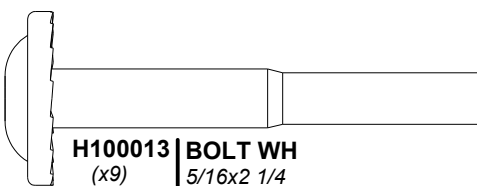
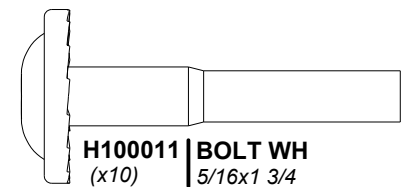
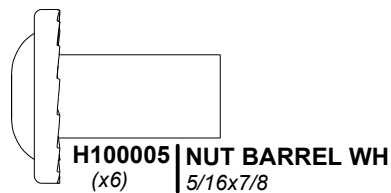
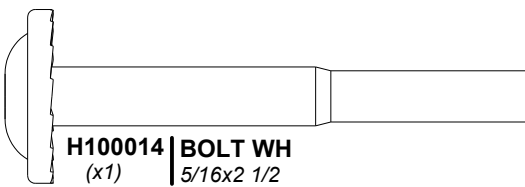
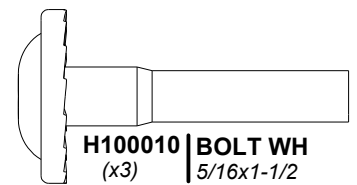
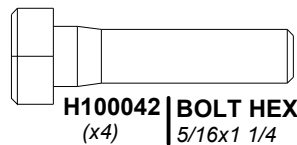
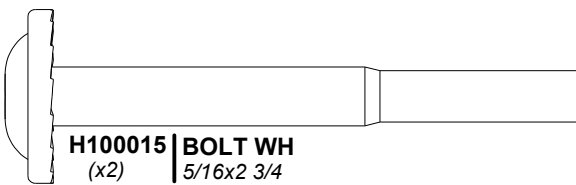
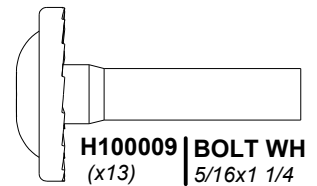
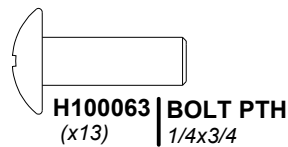
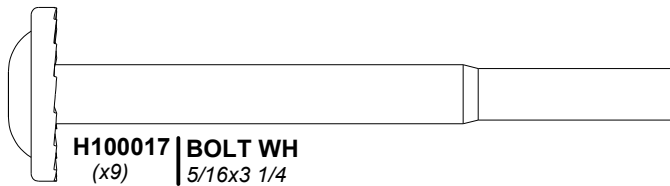
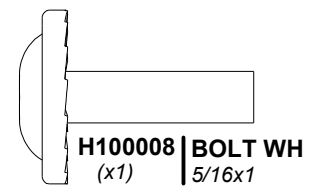
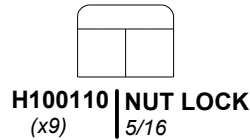
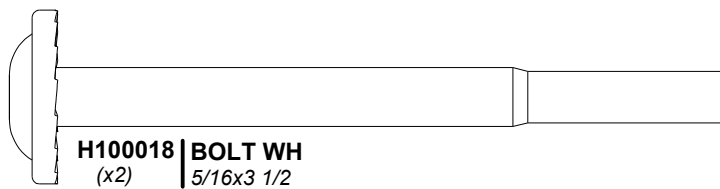
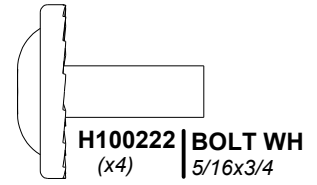
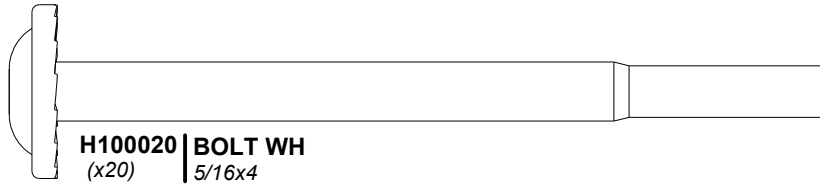
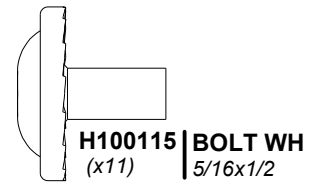

Owners Manual - Parts Identification

Hardware Components

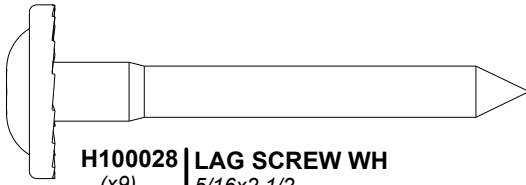

H100028 | LAG SCREW WH
(x9) | 5/16x2 1/2



H100128 | SCREW PWH
(x7) | 8x5/8

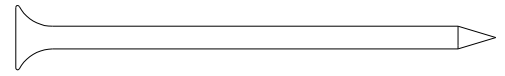

H100090 | SCREW PFH
(x26) | 8x2 1/2"

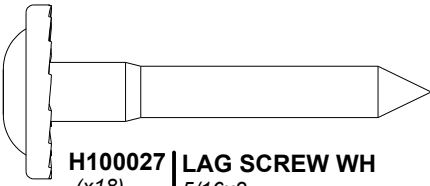

H100027 | LAG SCREW WH
(x18) | 5/16x2

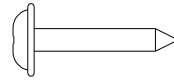

H100070 | SCREW PWH
(x22) | 8x3/4

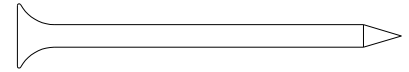

H100111 | SCREW PFH
(x90) | 8x2

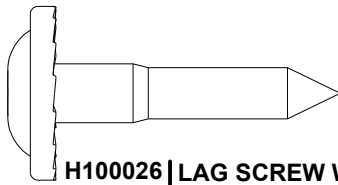

H100026 | LAG SCREW WH
(x2) | 5/16x1 1/2

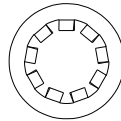

H100108 | WASHER LOCK INT
(x13) | 8x15

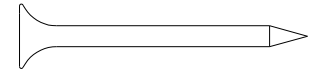

H100086 | SCREW PFH
(x76) | 8x1 1/2

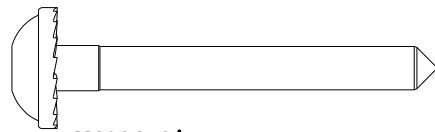

H100146 | LAG SCREW WH
(x4) | 1/4x2

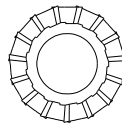

H100138 | WASHER LOCK EXT
(x4) | 6x15

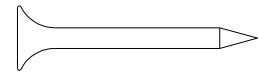

H100087 | SCREW PFH
(x93) | 8x1 1/4

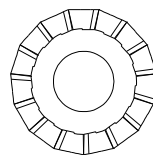

H100030 | WASHER LOCK EXT
(x107) | 8x19



H100088 | SCREW PFH
(x238) | 8x1 1/8



H100083 | SCREW TAPPING
(x15) | 14x3/4

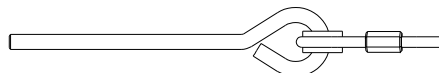

H100099 | SWING HANGER
(x6) | 5/16x9 1/2

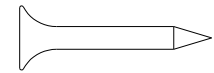

H100085 | SCREW PFH
(x4) | 8x1

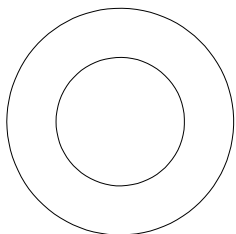

H100103 | WASHER SAFETY
(x4) | 17x30

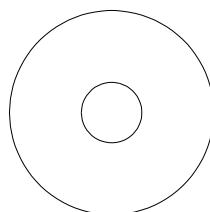

H100105 | WASHER FLAT
(x15) | 8x27

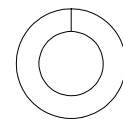

H100095 | WASHER SPLIT
(x4) | 5/16

Owners Manual - Parts Identification

Accessory Components (Not to Scale)

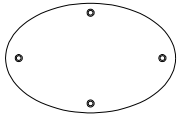

A100164 | **BYD ID TAG**
(x1) | **(LARGE) AGES**
3-10

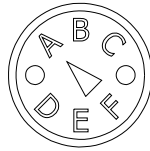

A100314 | **"A" REVISION**
(x1) | **TAG**

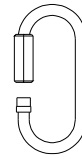

A100069 | **QUICK LINK**
(x6)

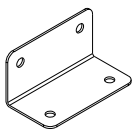

A100140 | **L BRACKET**
(x2) | **66x66x127**

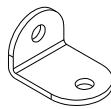

A100061 | **L BRACKET**
(x7) | **GREEN 32x51**

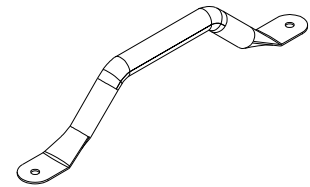

A100118 | **HAND GRIP**
(x4) | **METAL GREEN**
381 c/c

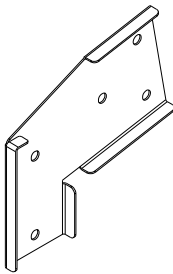

A100325 | **SWING BEAM**
(x1) | **EXTENSION**
BRACKET-LEFT

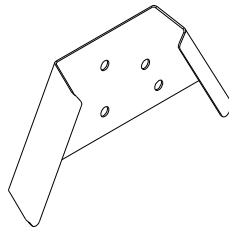

A4M01169 | **A-FRAME BRACKET**
(x1)

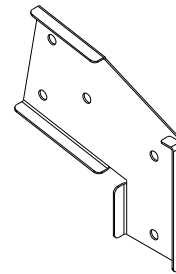

A100326 | **SWING BEAM**
(x1) | **EXTENSION**
BRACKET-RIGHT



A100087 | **ROPE-CHAIN GREEN 51.25"**
(x4)

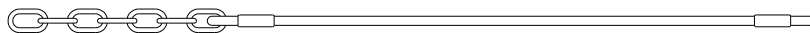

A100083 | **ROPE-CHAIN GREEN 33"**
(x2)

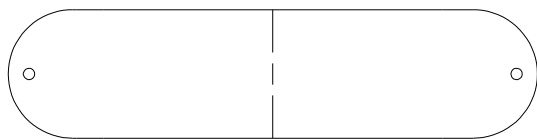

A100171 | **SWING SEAT YELLOW 22"**
(x2)

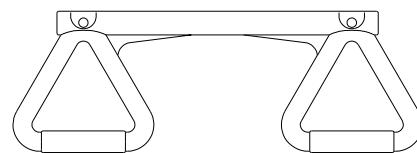

A6P00034 | **TRAPEZE YELLOW**
(x1)

Owners Manual - Parts Identification

Accessory Components (Not to Scale)

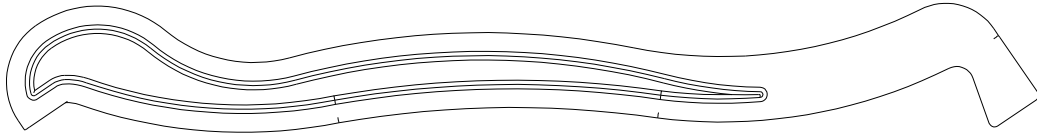

A100054 | SLIDE RAIL 8' GREEN RIGHT
(x1)



A100055 | SLIDE RAIL 8' GREEN LEFT
(x1)

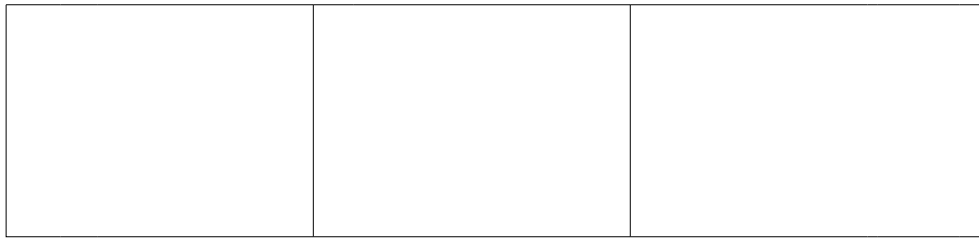

A100056 | SLIDE BED 8' YELLOW
(x1)

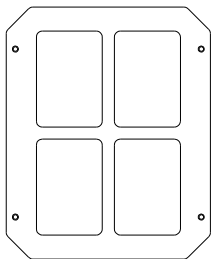

A100146 | WINDOW 216x267 GREEN
(x5)

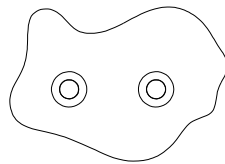

A6P00037 | GREEN HC ROCK
(x3) | #2

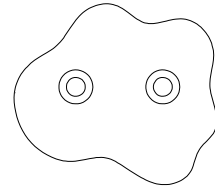

A6P00036 | GREEN HC ROCK
(x3) | #1

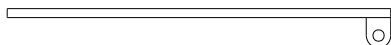

A4M00527 | GROUND STAKE REBAR
(x2)

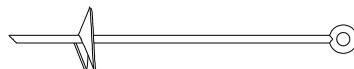

A100178 | AUGER GROUND STAKE
(x6)

PRE-ASSEMBLY STEP 1 - SORTING PARTS

It is critical for ease of assembly that you take the time to sort and organize the wood and hardware.

WOOD PARTS:

- Organize wood parts by the three-digit, alpha-numeric number stamped on each board (ex. P01).
- If there are multiple boards with the same stamped number, stack those pieces together.
- Stamps can be found on the flat surface of the boards or on the end of the boards.
- Allow yourself plenty of room - the wood pieces can take up a significant amount of space.

NOTE: CARTONS ARE NOT ORGANIZED BY BOARD NUMBER.

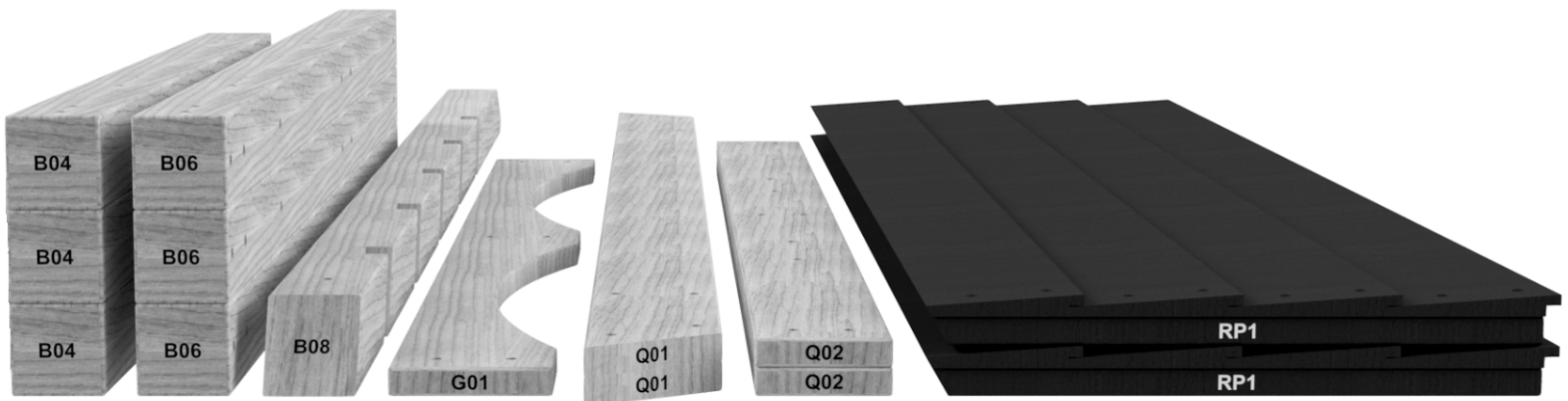

HARDWARE PARTS:

- We recommend that you have a separate table to organize the hardware.
- Hardware bags are printed with a seven-digit, alpha-numeric part number.
- You can organize your hardware by part number or group by hardware type (i.e. bolts, nuts, etc.).
- During assembly you only need to reference the last four digits of the number.

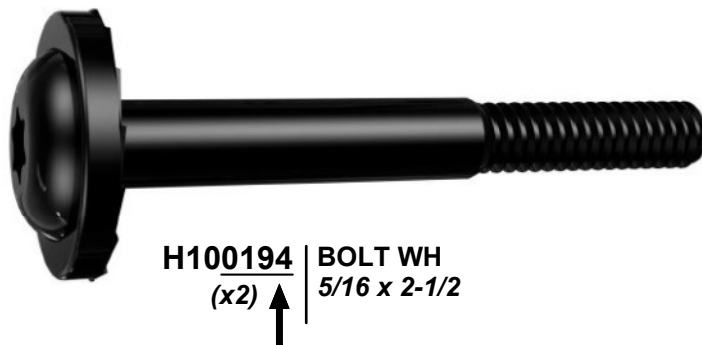

PRE-ASSEMBLY STEP 2 - TOOLS REQUIRED



Cordless Drill or
Electric Drill



Drill Attachments:
Phillips Head



1/8", 3/16", 3/8" & 7/16"
Drill Bits



Phillips Screw Driver



Open End Wrenches 1/2" & 9/16"



3/8" Drive Ratchet, 1/2" &
9/16" STD Sockets 1/2" & 9/16"
Deep Sockets



Claw Hammer



Rubber Mallet - Optional



Tape Measure

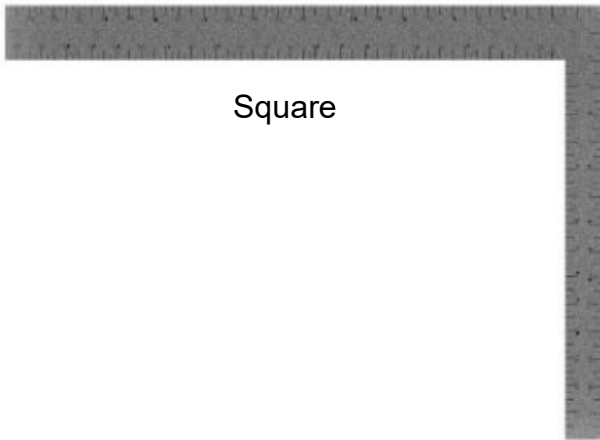

Square



Level 24"

PRE-ASSEMBLY STEP 3 - CHOOSE YOUR ASSEMBLY METHOD

There are several types of assembly instructions available to you.

1. Printed Assembly Manual included with your set
2. BILT APP - 3D interactive instructions
3. Combination of the Printed Manual and BILT APP
(Note: Step numbers can differ between the two methods)



STEP 1 - LADDER ASSEMBLY

QTY	PART NUMBER	DESCRIPTION
8	H100111	SCREW PFH 8x2



H6 | LEFT UPRIGHT - W4L16265
(x1) | 1"x3 3/8"x50 3/4" (24x86x1290)



M18 | LADDER RUNG - W4L16262
(x4) | 1"x3 3/8"x17 1/8" (24x86x434)

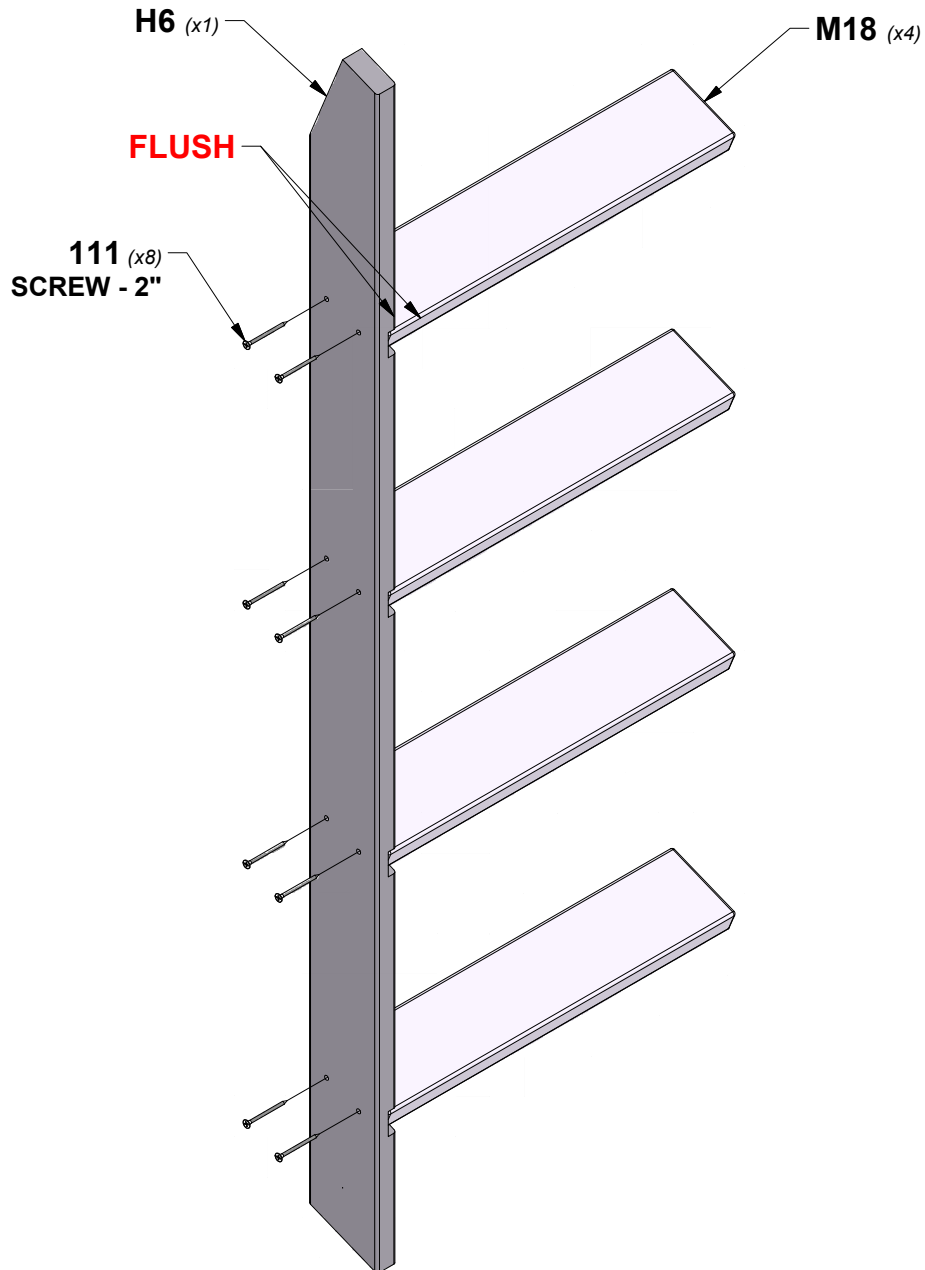

STEP 2 - LADDER ASSEMBLY

QTY	PART NUMBER	DESCRIPTION
8	H100111	SCREW PFH 8x2



H6 | LEFT UPRIGHT - W4L16265
(x1) | 1"x3 3/8"x50 3/4" (24x86x1290)

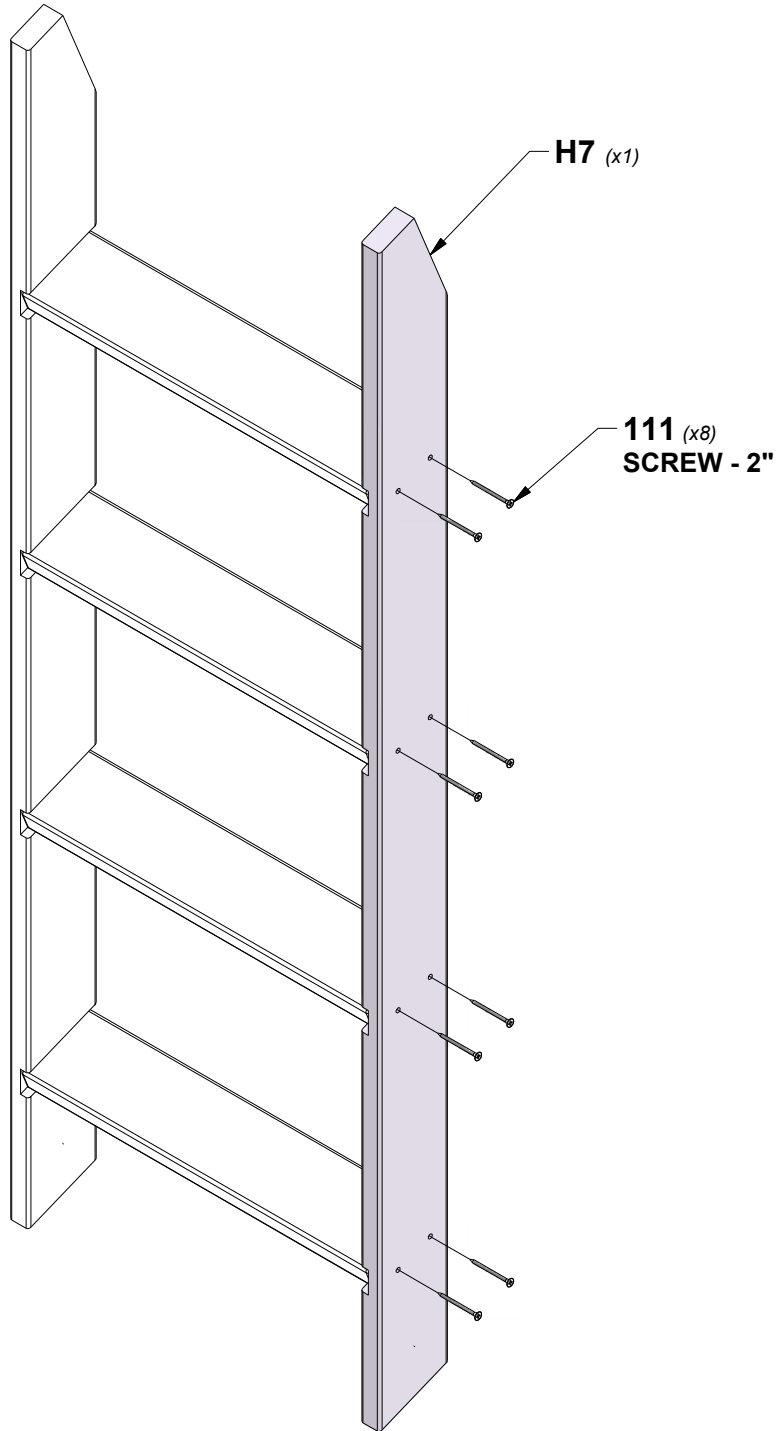

STEP 3 - LADDER ASSEMBLY

QTY	PART NUMBER	DESCRIPTION
8	H100086	SCREW PFH 8x1-1/2"



M19 | ATTACHMENT BOARD - W4L16263
(x1) | 5/8"x3 3/8"x18 1/4" (16x86x462)



M20 | REAR SUPPORT - W4L16264
(x1) | 5/8"x3 3/8"x18 1/4" (16x86x462)

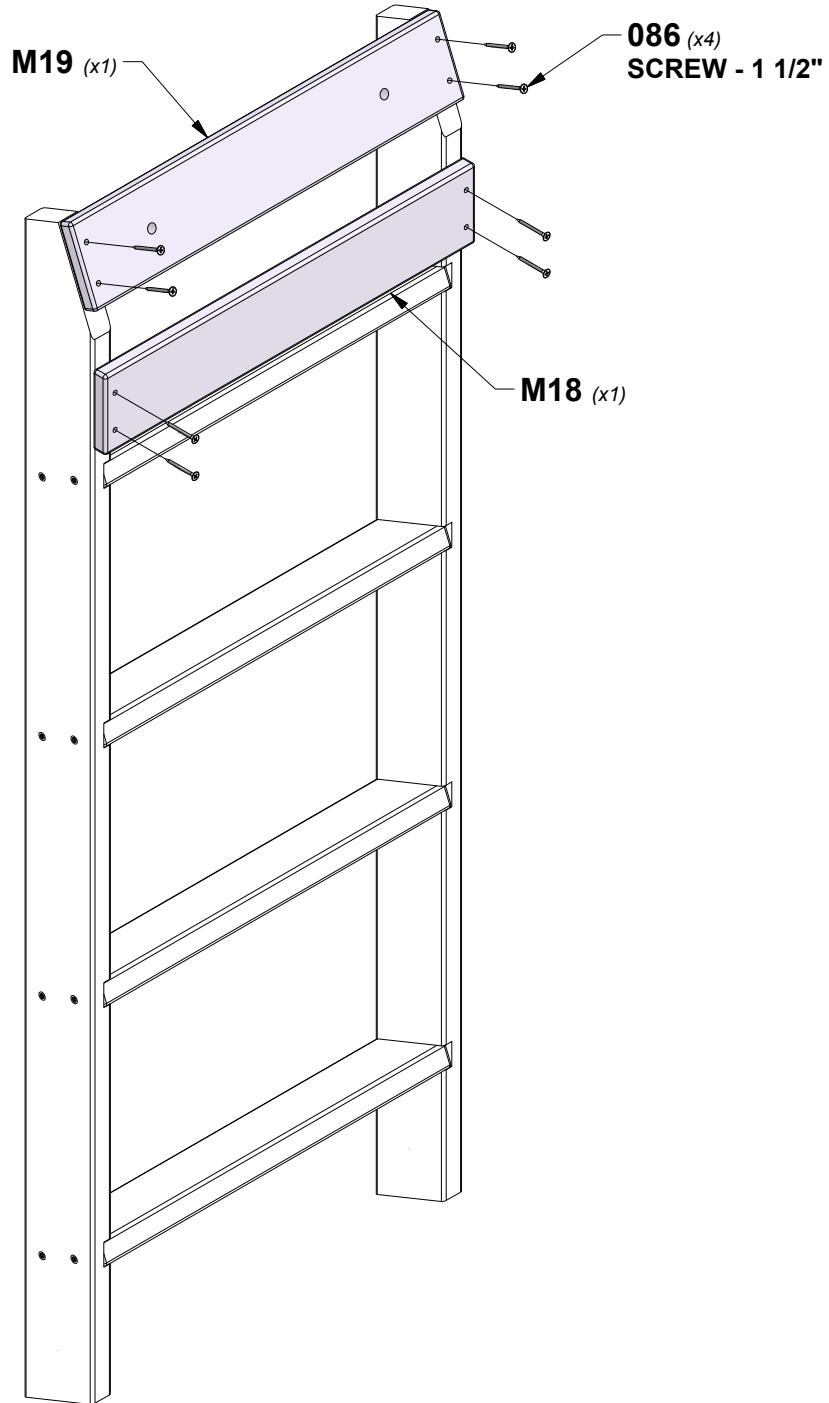

STEP 1 - BAY WINDOW ASSEMBLY

QTY	PART NUMBER	DESCRIPTION
8	H100088	SCREW PFH 8x1-1/8"



N5 | BAY WINDOW BOARD - W100592
 (x2) | 5/8"x2 3/8"x13 1/8" (16x60x332)



N9 | BAY WINDOW BOARD - W100596
 (x2) | 5/8"x2 3/8"x6 1/4" (16x60x158)

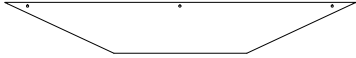

L6 | BAY WINDOW HEADER - W100571
 (x2) | 5/8"x4 3/8"x30 1/2" (16x112x774)

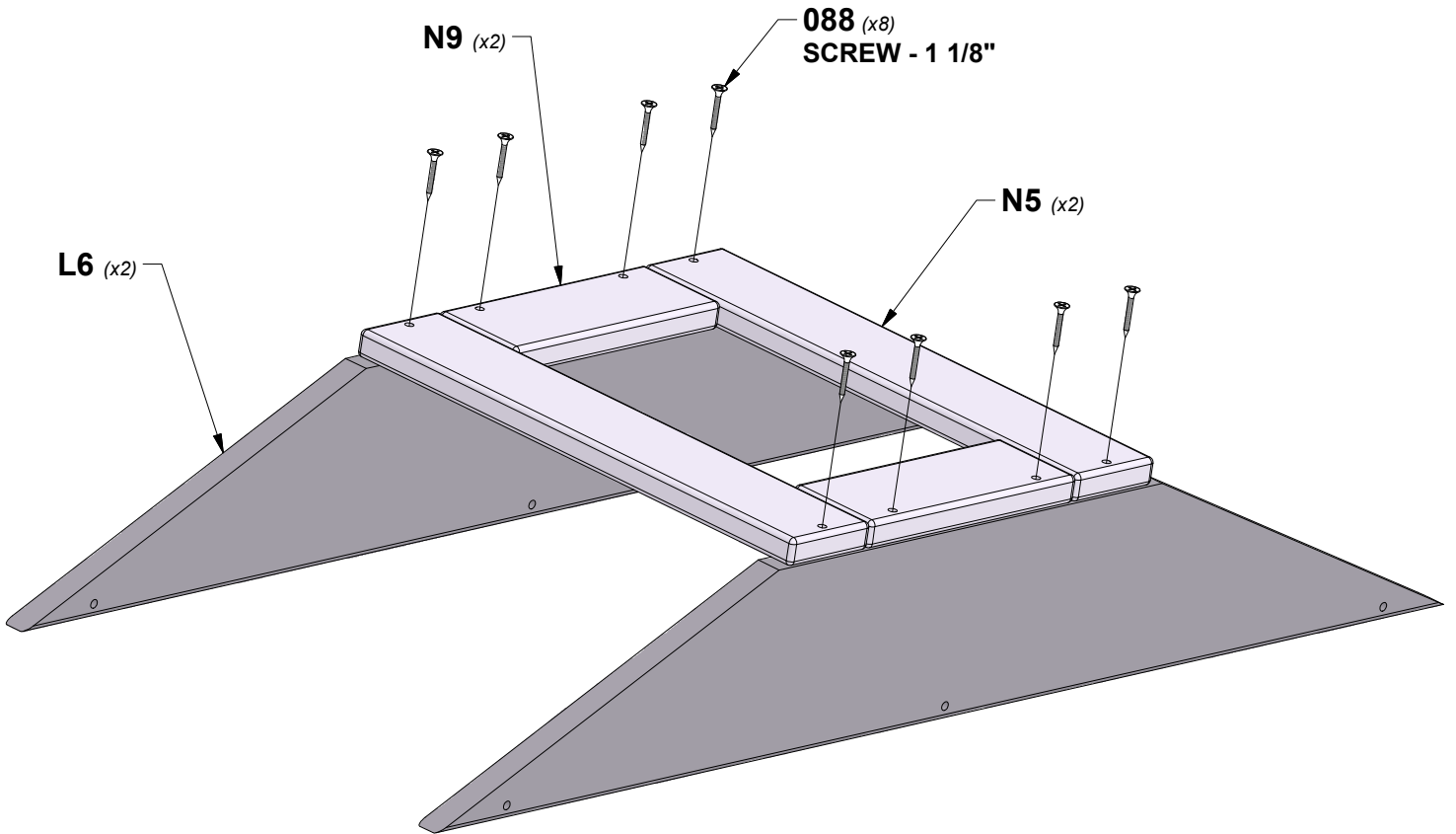

STEP 2 - BAY WINDOW ASSEMBLY

QTY	PART NUMBER	DESCRIPTION
8	H100088	SCREW PFH 8x1-1/8"



N5 | BAY WINDOW BOARD - W100592
(x2) | 5/8"x2 3/8"x13 1/8" (16x60x332)



N9 | BAY WINDOW BOARD - W100596
(x2) | 5/8"x2 3/8"x6 1/4" (16x60x158)

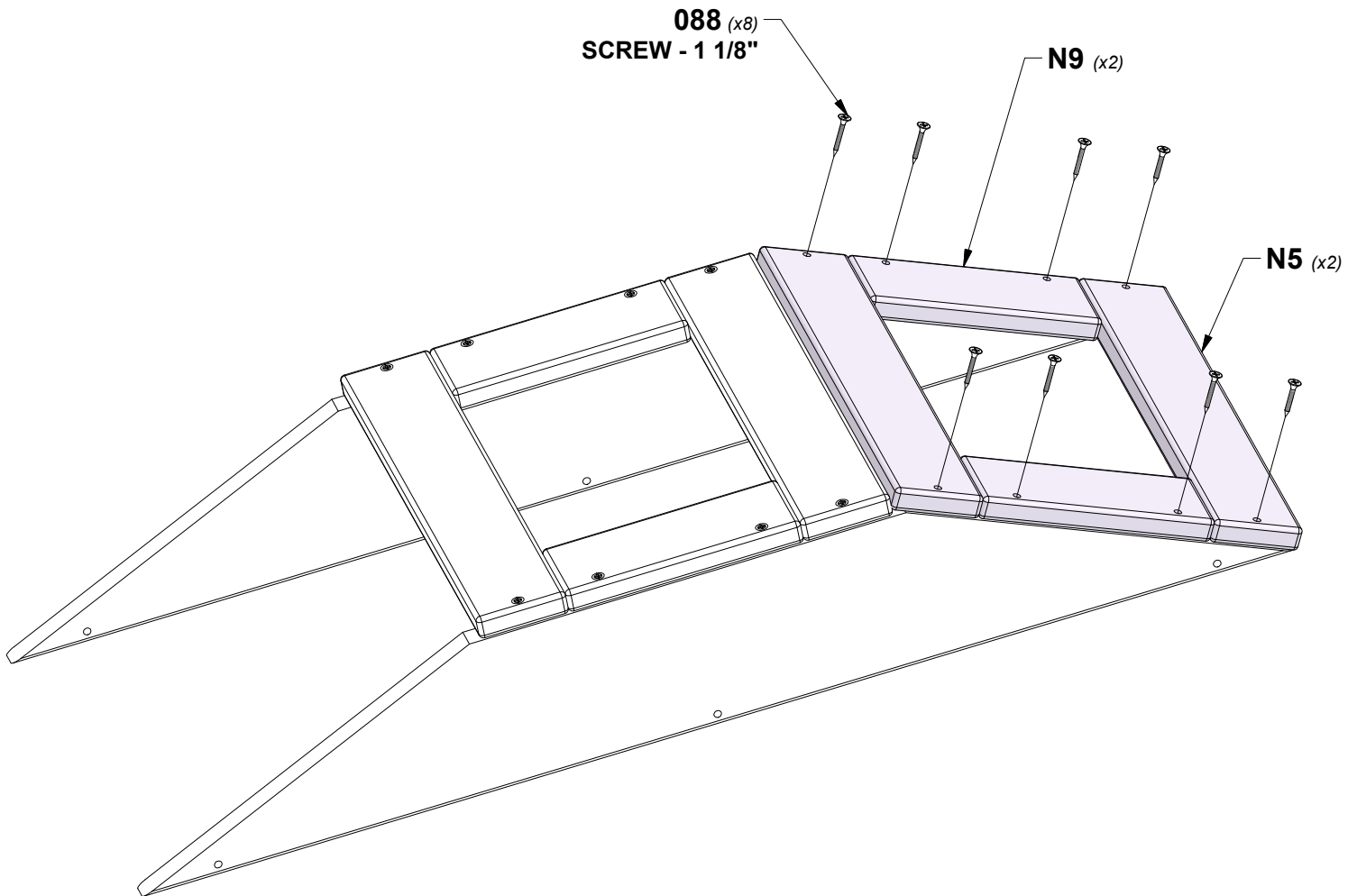

STEP 3 - BAY WINDOW ASSEMBLY

QTY	PART NUMBER	DESCRIPTION
8	H100088	SCREW PFH 8x1-1/8"



N5 | BAY WINDOW BOARD - W100592
(x2) | 5/8"x2 3/8"x13 1/8" (16x60x332)



N9 | BAY WINDOW BOARD - W100596
(x2) | 5/8"x2 3/8"x6 1/4" (16x60x158)

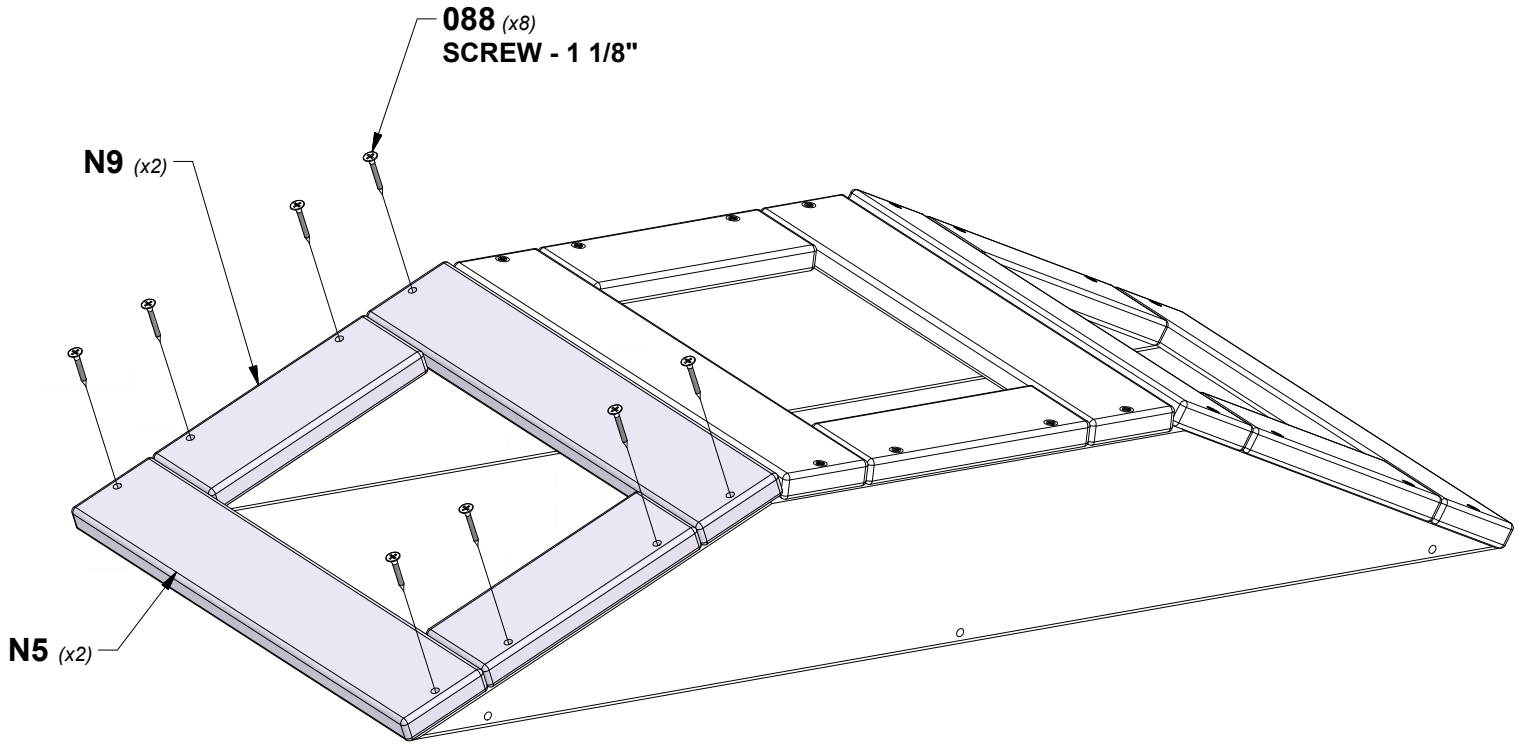

STEP 4 - BAY WINDOW ASSEMBLY

QTY	PART NUMBER	DESCRIPTION
12	H100070	SCREW PWH 8x3/4

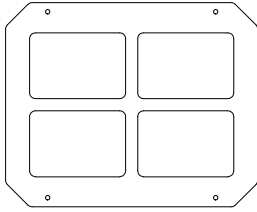

A100146
(x3) | **WINDOW 216x267 GREEN**

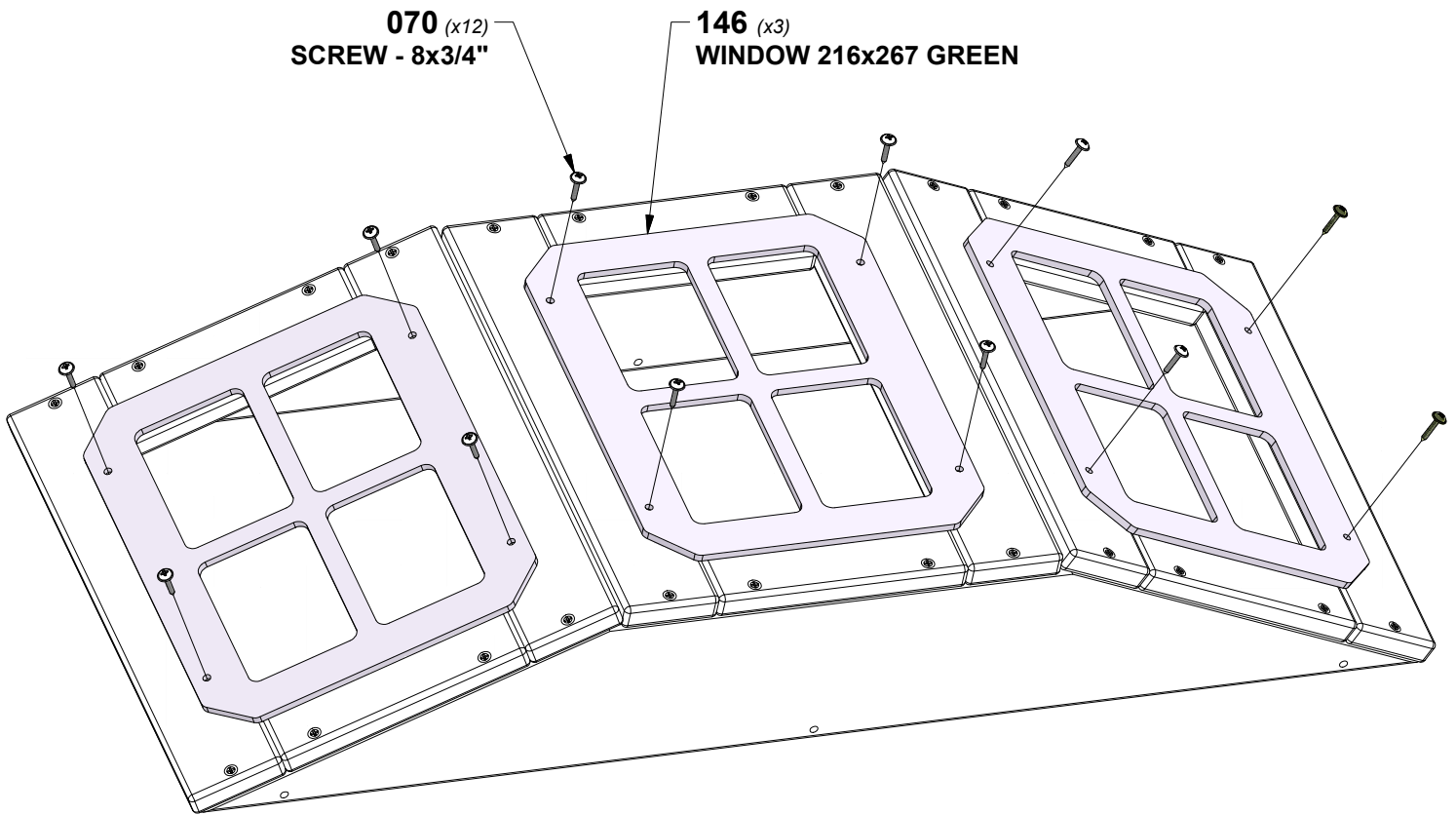

STEP 1 - ROCK WALL ASSEMBLY

QTY	PART NUMBER	DESCRIPTION
12	H100063	BOLT PTH 1/4x3/4
12	H100072	T-NUT 1/4
12	H100108	WASHER LOCK INT 8x15



M29 | ROCK WALL BOARD - W4L16270
(x6) | 5/8"x3 1/2"x20 1/4" (16x90x514)



A6P00036 | GREEN HC ROCK #1
(x3)



A6P00037 | GREEN HC ROCK #2
(x3)

TIP:
INSTALL T-NUTS INTO
BOARDS BEFORE ASSEMBLY

INSTALL WITH FINGER GRIPS UPWARD.
****PLACE ROCKS AS DESIRED****

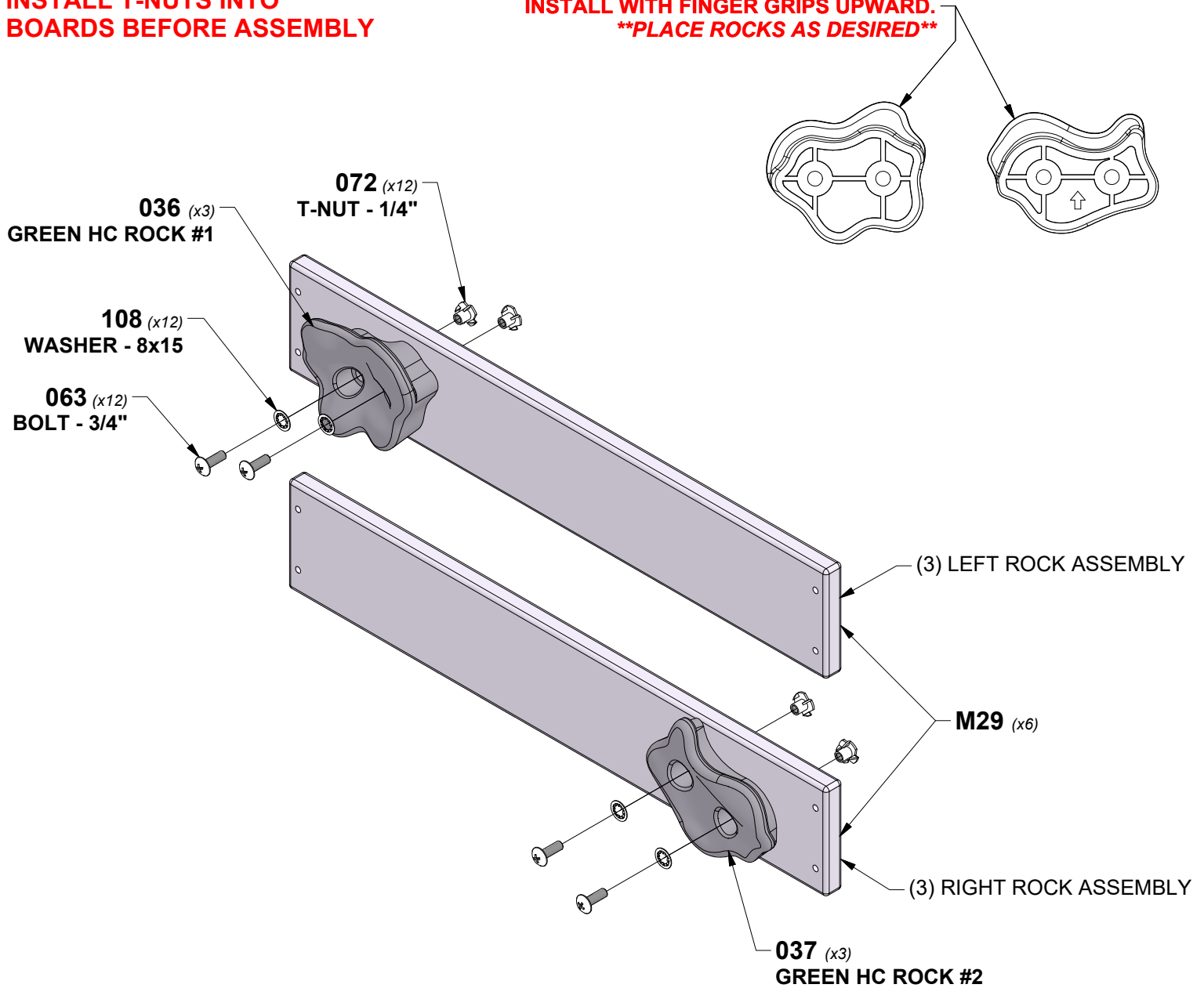

STEP 2 - ROCK WALL ASSEMBLY

QTY	PART NUMBER	DESCRIPTION
56	H100086	SCREW PFH 8x1-1/2"



M26 | ROCK WALL BOARD - W4L16272
(x8) | 5/8"x3 3/8"x23 1/4" (16x86x590)



E30 | ROCKWALL RAIL - W4L16273
(x2) | 1 3/8"x3 3/8"x48 3/4" (36x86x1239)

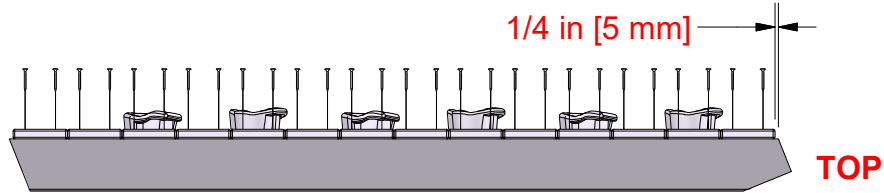

SIDE VIEW

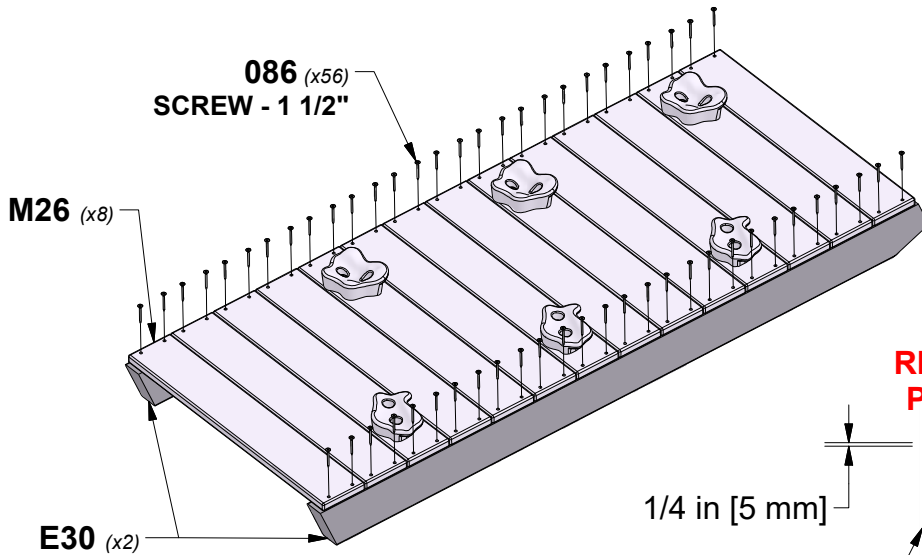

**TOP
RECOMMENDED BOARD
PLACEMENT PATTERN**

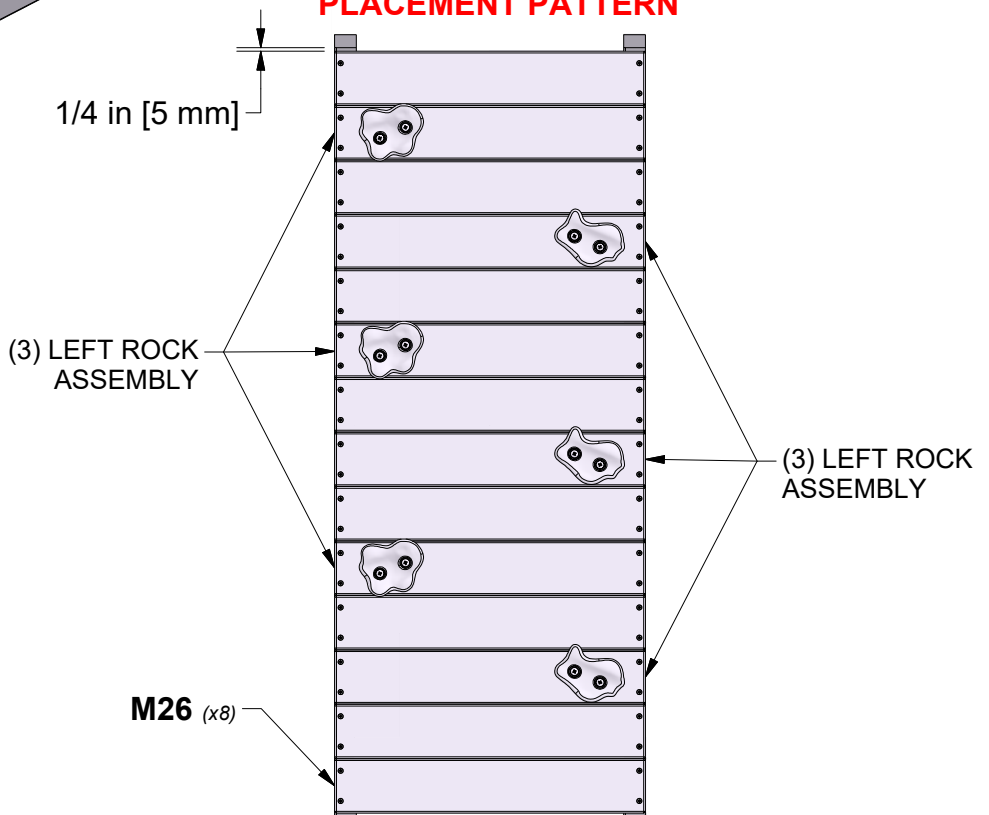

STEP 3 - ROCK WALL ASSEMBLY

QTY	PART NUMBER	DESCRIPTION
4	H100086	SCREW PFH 8x1-1/2"



M30 | ROCK WALL END BOARD - W4L16269
(x1) | 5/8"x3 7/8"x20 1/4" (16x100x514)

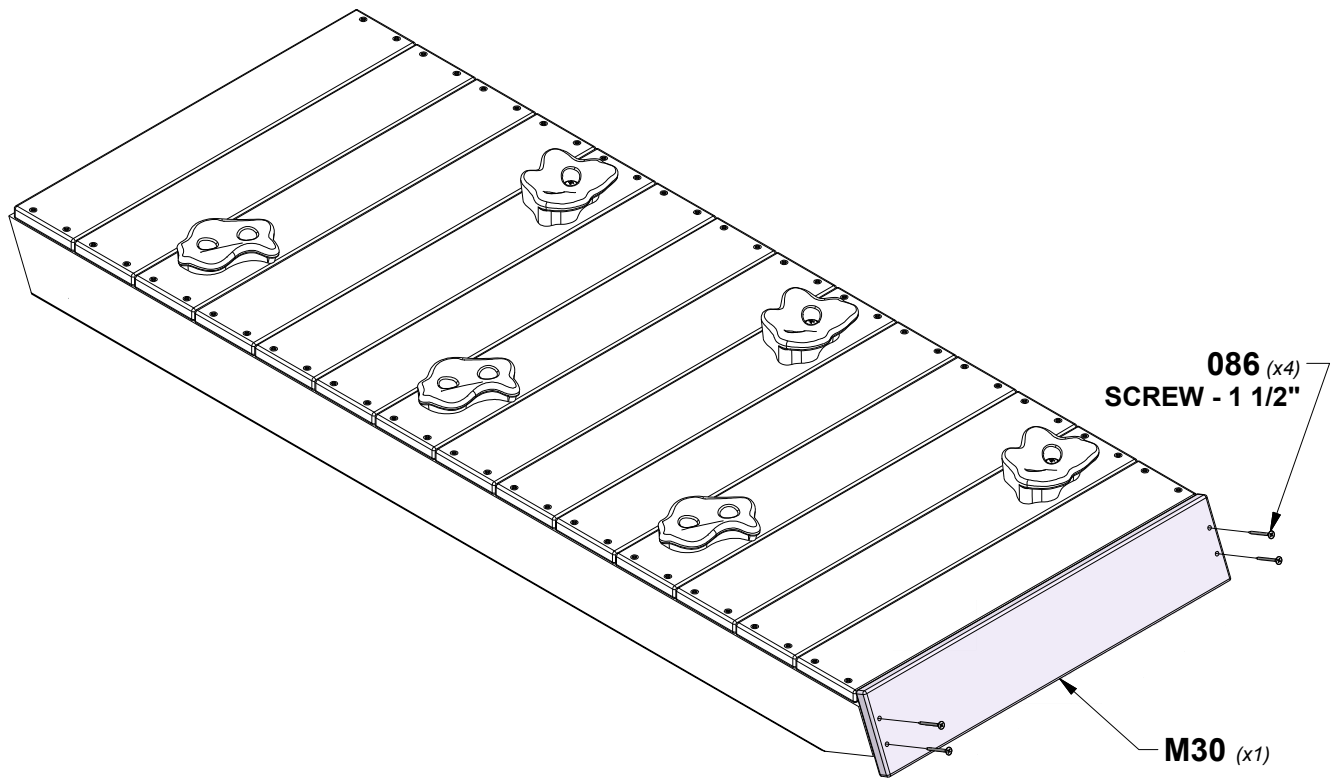

SIDE VIEW

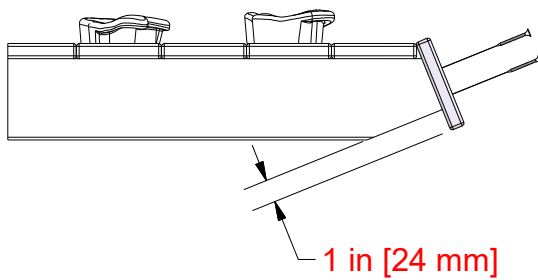

STEP 4 - ROCK WALL ASSEMBLY

QTY	PART NUMBER	DESCRIPTION
2	H100074	T-NUT 5/16
4	H100086	SCREW PFH 8x1-1/2"



J2 | ATTACHMENT BOARD - W4L16268
 (x1) | 1"x3 3/8"x20 1/4" (24x86x514)

TIP:
INSTALL T-NUTS INTO BOARDS
BEFORE ASSEMBLY

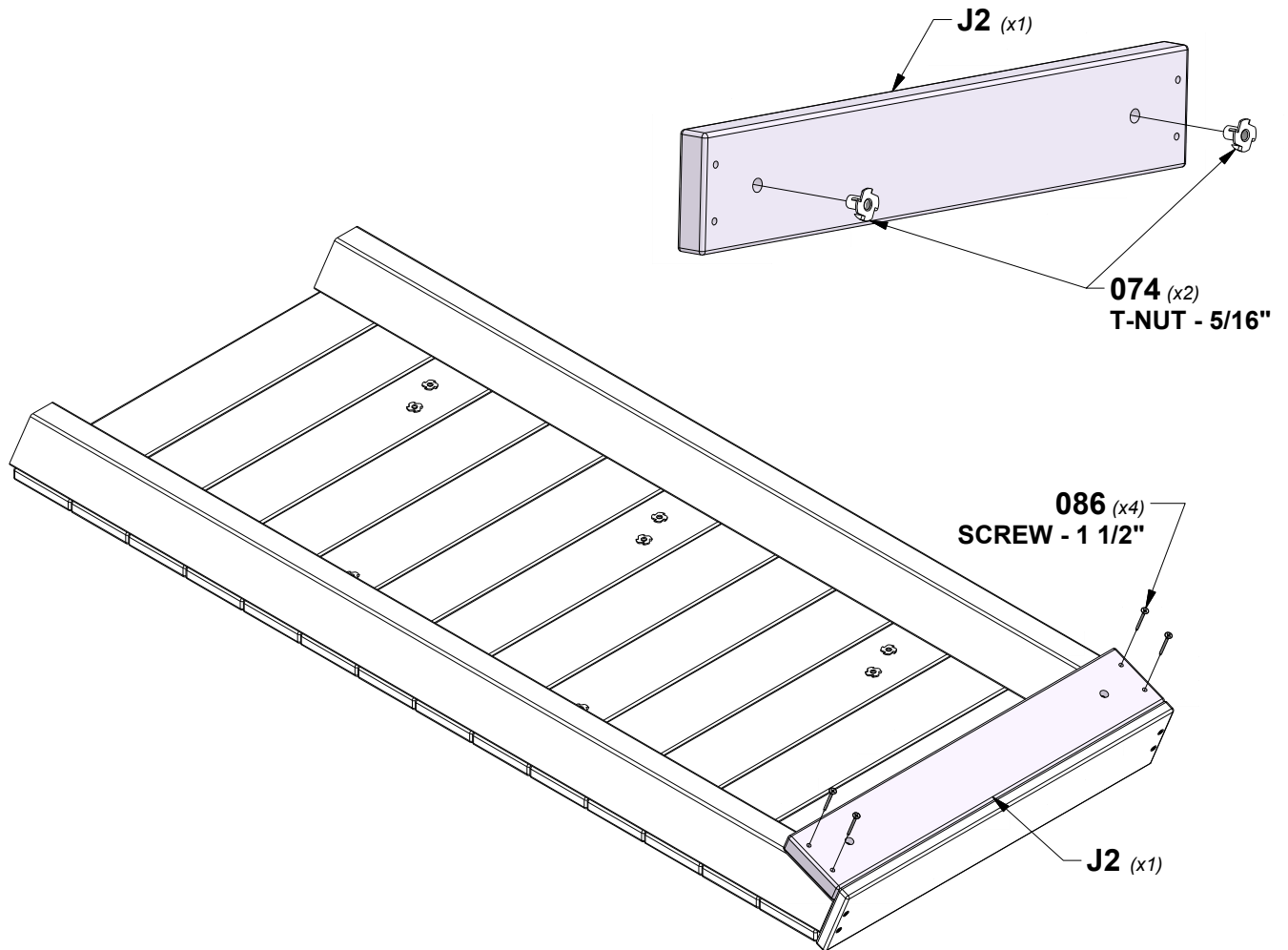

SIDE VIEW

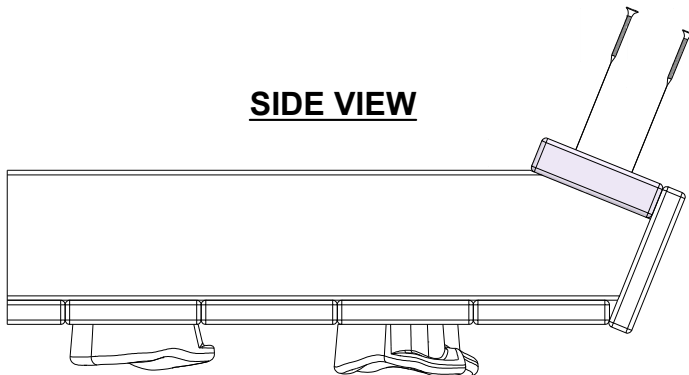

NOTE:
T-NUTS TO THE INSIDE
WHEN INSTALLING BOARD

STEP 1 - SLIDE ASSEMBLY

QTY	PART NUMBER	DESCRIPTION
3	H100074	T-NUT 5/16
3	H100115	BOLT WH 5/16x1/2



A100056 | SLIDE BED 8' YELLOW
(x1)

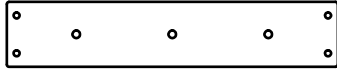

M77 | SLIDE BRACE - W100544
(x1) | 5/8"x3 3/8"x17 1/4" (16x86x438)

NOTE: TAKE NOTE OF SLIDE BED SURFACE FINISH, THE DULL SIDE WILL BE TOWARDS THE GROUND. PLACE SLIDE BRACE CENTERED ON THE BOTTOM (DULL SIDE) AND 1/2" FROM THE EDGE. USE M77 BOARD AS A TEMPLATE FOR DRILLING BOTTOM HOLE PATTERN IN SLIDE BED. USE A 5/16" DRILL BIT.

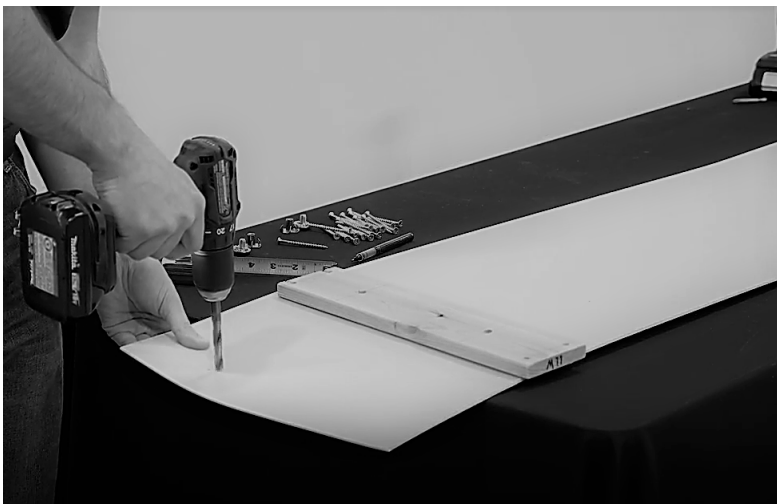
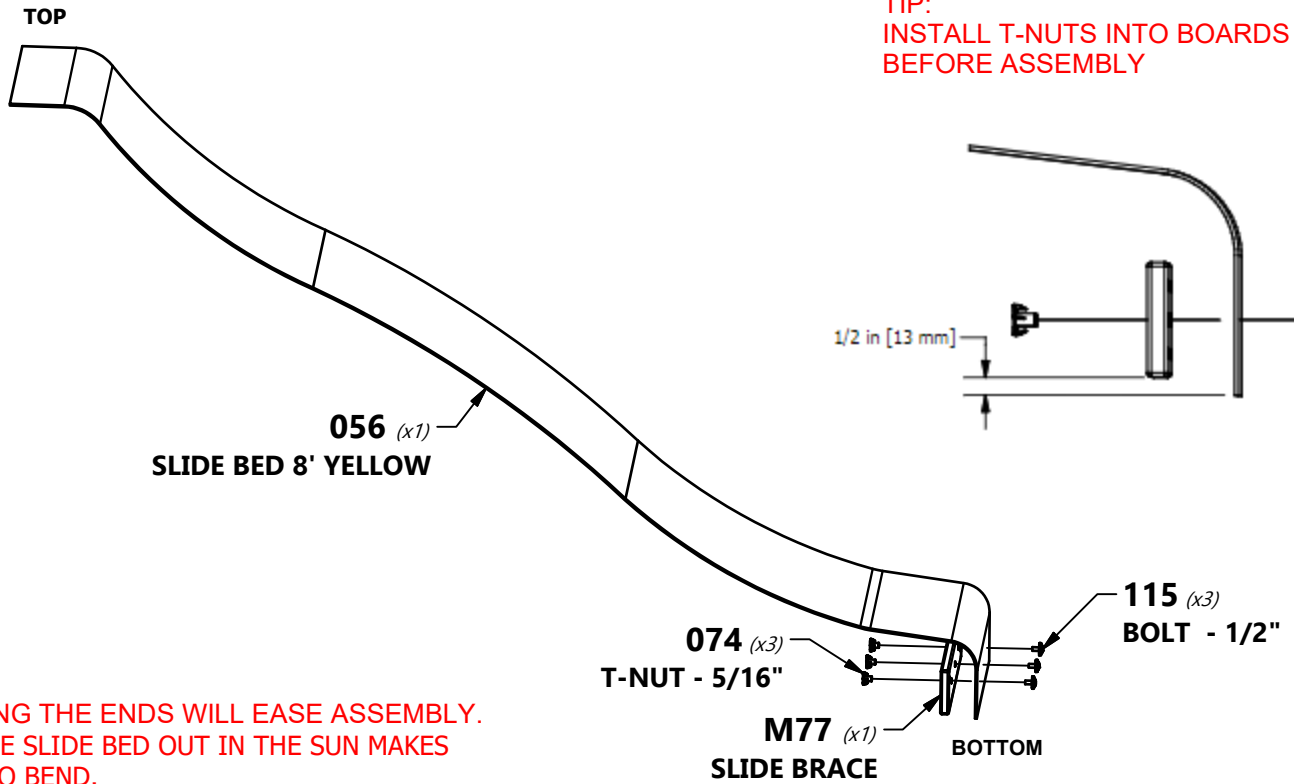

STEP 2 - SLIDE ASSEMBLY

QTY	PART NUMBER	DESCRIPTION
24	H100090	SCREW PFH 8x2 1/2



A100054 | SLIDE RAIL 8' GREEN RIGHT
(x1)



A100055 | SLIDE RAIL 8' GREEN LEFT
(x1)

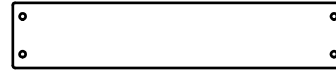

M78 | CENTER SLIDE BRACE - W100545
(x2) | 5/8"x3 3/8"x17 1/4" (16x86x438)

NOTE:

USING A 1/8" DRILL BIT, DRILL PILOT HOLES IN EACH INDENTATION ALONG EACH SIDE RAIL. THERE SHOULD BE 12 INDENTIONS ON EACH RAIL.

PLACE THE SLIDE RAIL ON FLAT SURFACE. STARTING AT THE BOTTOM, INSERT THE SLIDE BED INTO THE CHANNEL ON THE INSIDE OF THE RAIL. HOLD THE SLIDE BED IN PLACE WHILE A HELPER BENDS THE SLIDE BED INTO THE CHANNEL. MAKE SURE THE SLIDE BED IS COMPLETELY INSERTED INTO THE CHANNEL.

INSERT THE TWO CENTER SLIDE BRACES INTO THEIR RESPECTIVE LOCATIONS. SECURE THE SLIDE BED AND CENTER USING THE PROVIDED HARDWARE.

REPEAT THIS PROCESS FOR THE OPPOSITE SLIDE RAIL.



FAILURE TO INSERT SLIDE BED PROPERLY MAY RESULT IN INJURY OR AMPUTATION. EXPOSED SLIDE EDGES CAN BE SHARP AND BECOME A LACERATION HAZARD IF THE SLIDE IS NOT PROPERLY ASSEMBLED.

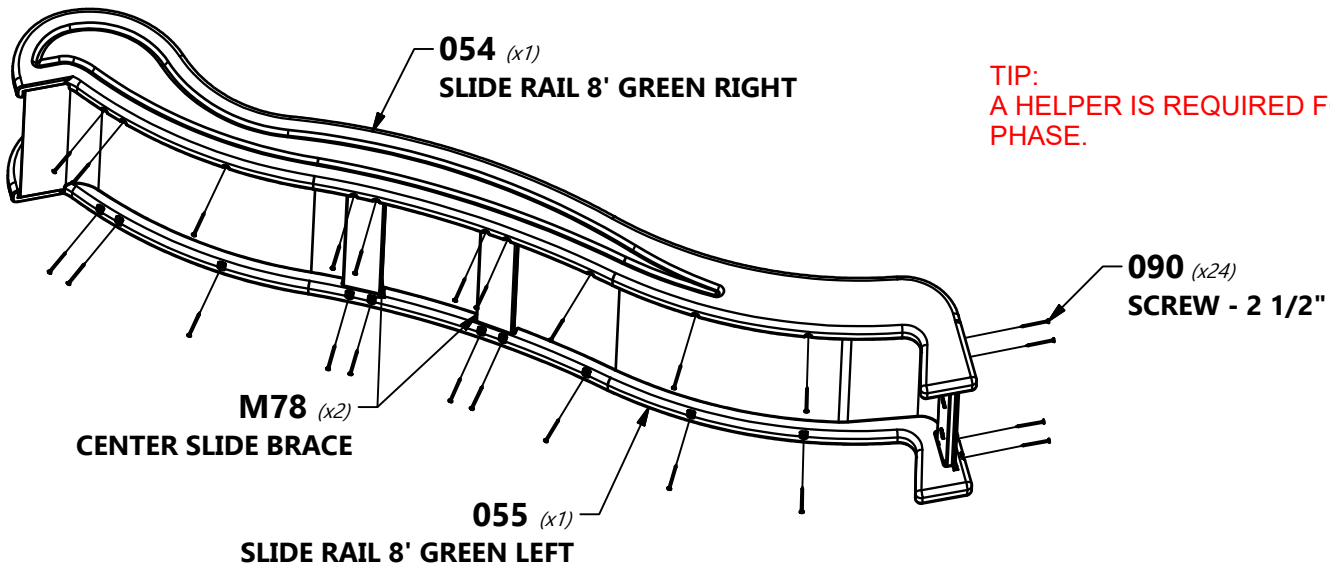

TIP:
A HELPER IS REQUIRED FOR THIS PHASE.



STEP 1 - SWING BEAM ASSEMBLY

QTY	PART NUMBER	DESCRIPTION
3	H100005	NUT BARREL WH 5/16x7/8
3	H100011	BOLT WH 5/16x1 3/4
2	H100047	BOLT HEX 5/16x2-3/4
4	H100105	WASHER FLAT 8x27
2	H100110	NUT LOCK 5/16



SB74 | SWING BEAM EXTENDED - W4L14650
(x1) | 2"x5 1/4"x89 1/2" (50x134x2274)

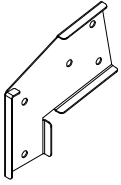

A100325 | SWING BEAM
EXTENSION
BRACKET-LEFT
(x1)

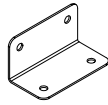

A100140 | L BRACKET
(x2) | 66x66x127

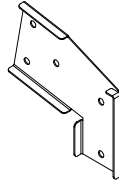

A100326 | SWING BEAM
EXTENSION
BRACKET-RIGHT
(x1)

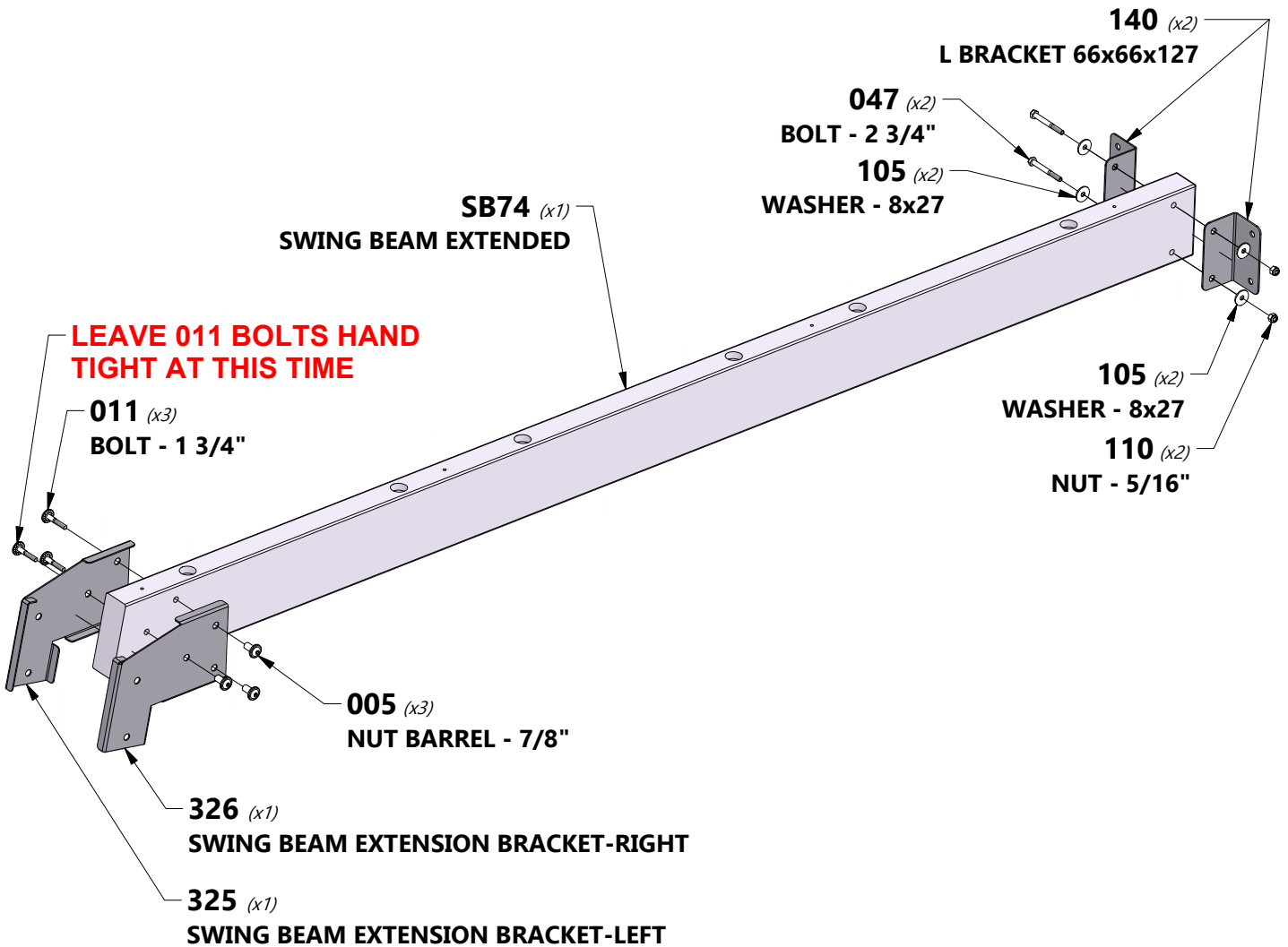

STEP 2 - SWING BEAM ASSEMBLY

QTY	PART NUMBER	DESCRIPTION
6	H100103	WASHER SAFETY 17x30
6	H100110	NUT LOCK 5/16
6	H100105	WASHER FLAT 8x27

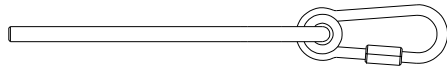

H100099 | SWING HANGER
(x6) 5/16x9 1/2

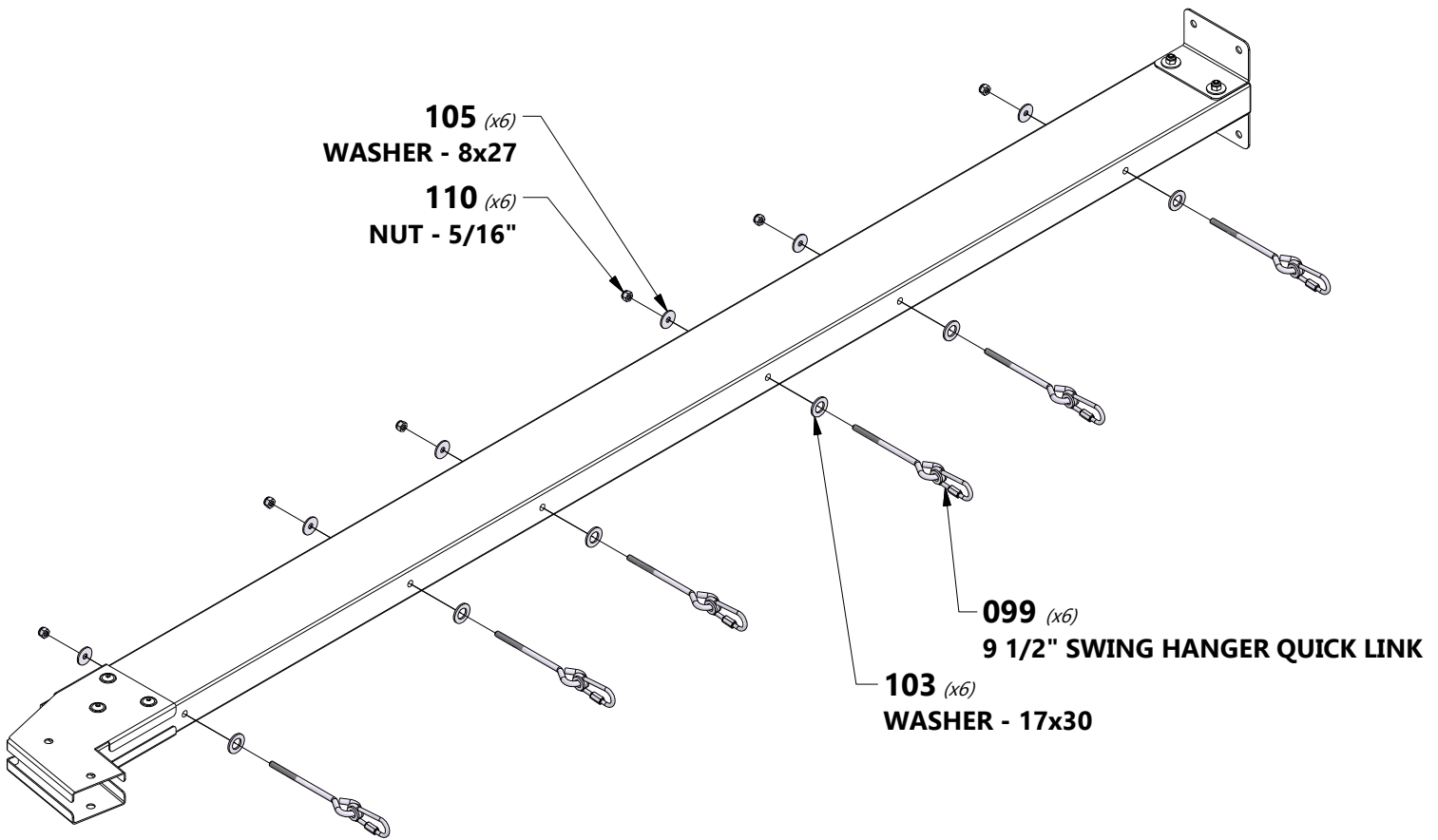
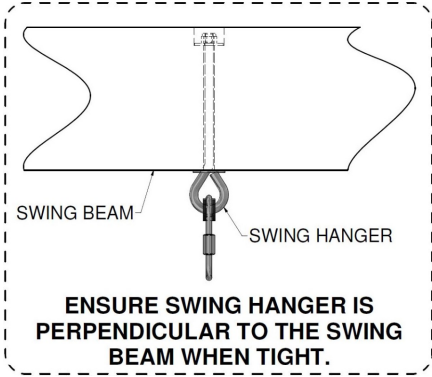

STEP 3 - SWING BEAM ASSEMBLY

QTY	PART NUMBER	DESCRIPTION
4	H100128	SCREW PWH 8x5/8



A100164 | BYD ID TAG
(x1)

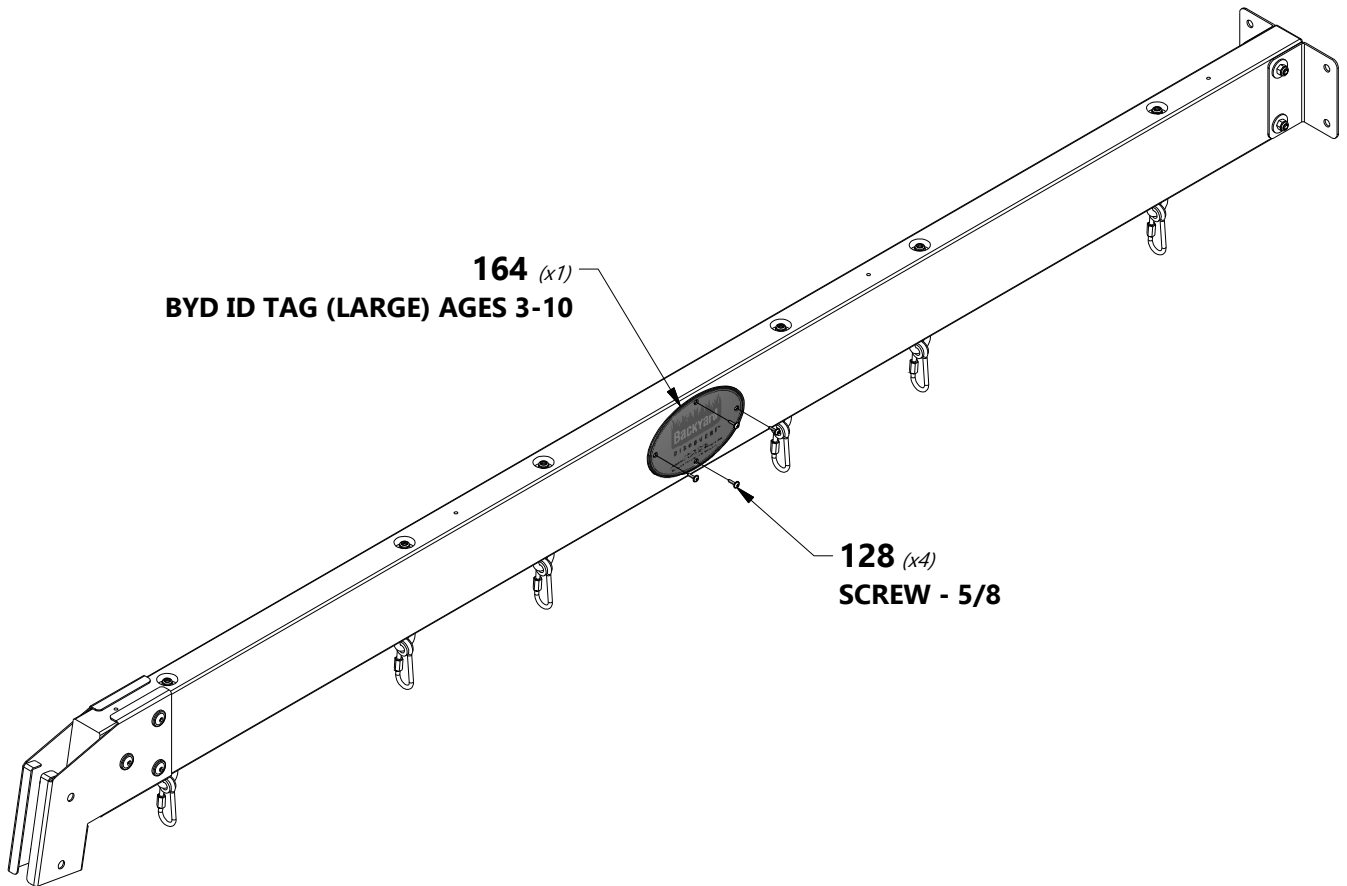

STEP 4 - SWING BEAM ASSEMBLY

QTY	PART NUMBER	DESCRIPTION
4	H100009	BOLT WH 5/16x1 1/4
2	H100018	BOLT WH 5/16x3 1/2
6	H100074	T-NUT 5/16

W71 | SWING BEAM SUPPORT - W4L14654
 (x1) | 2"x3 3/8"x50 3/8" (50x86x1280)

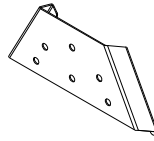

E77 | ANGLE BRACE - W4L14652
 (x2) | 1 3/8"x3 3/8"x81" (36x86x2056)

A4M01169 | A-FRAME BRACKET
 (x1)

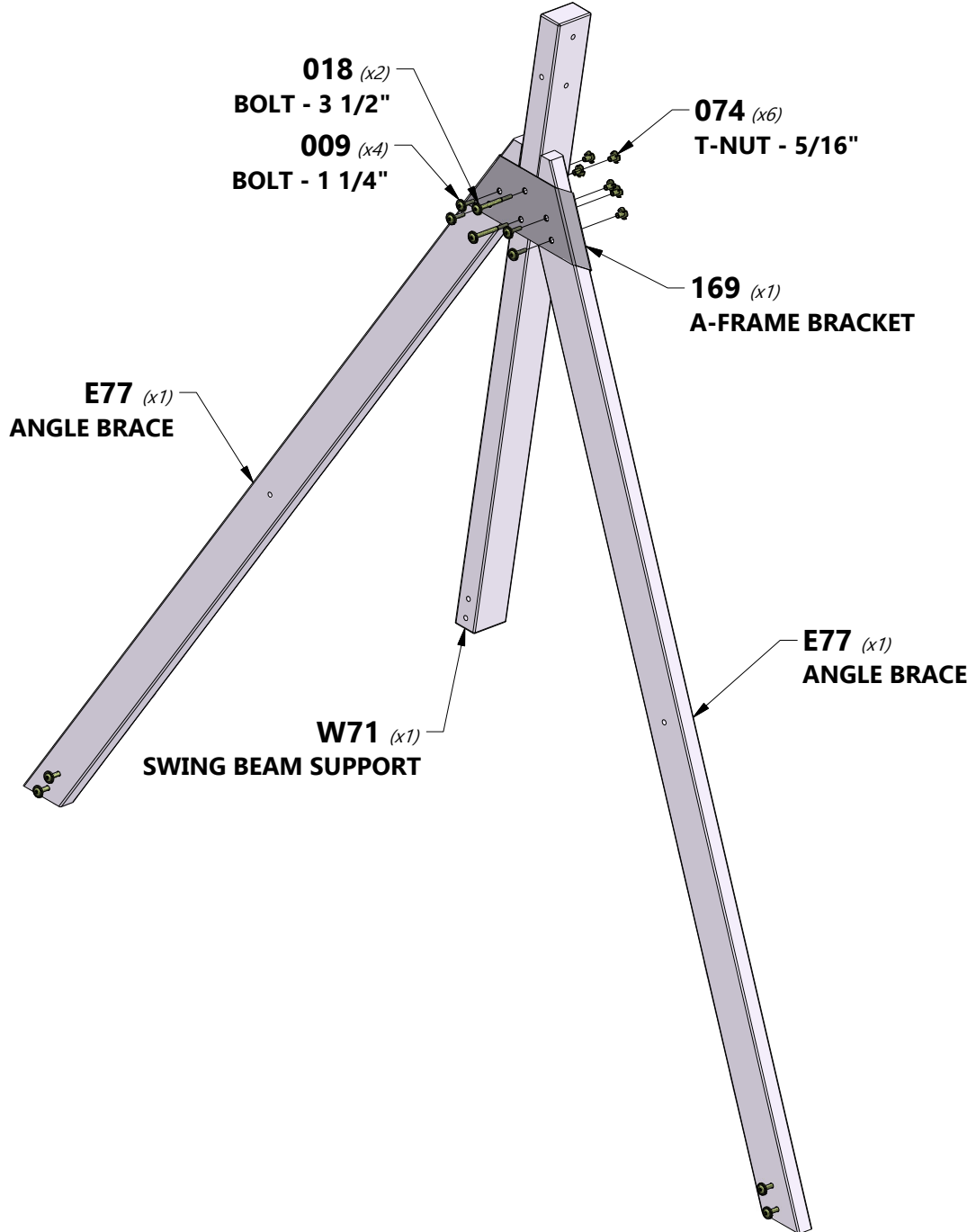

STEP 5 - SWING BEAM ASSEMBLY

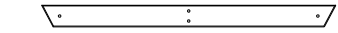

E50 | END SUPPORT - W4L14651
(x1) | 1 1/2"x3 1/2"x46" (36x86x1168)

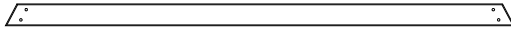

H80 | GROUND BOARD - W4L14653
(x1) | 1"x3 3/8"x79 1/2" (24x86x2018)

QTY	PART NUMBER	DESCRIPTION
1	H100013	BOLT WH 5/16x2 1/4
1	H100030	WASHER LOCK EXT 8x19
1	H100074	T-NUT 5/16
1	H100015	BOLT WH 5/16x2 3/4
1	H100505	BOLT WH 5/16x4 3/4

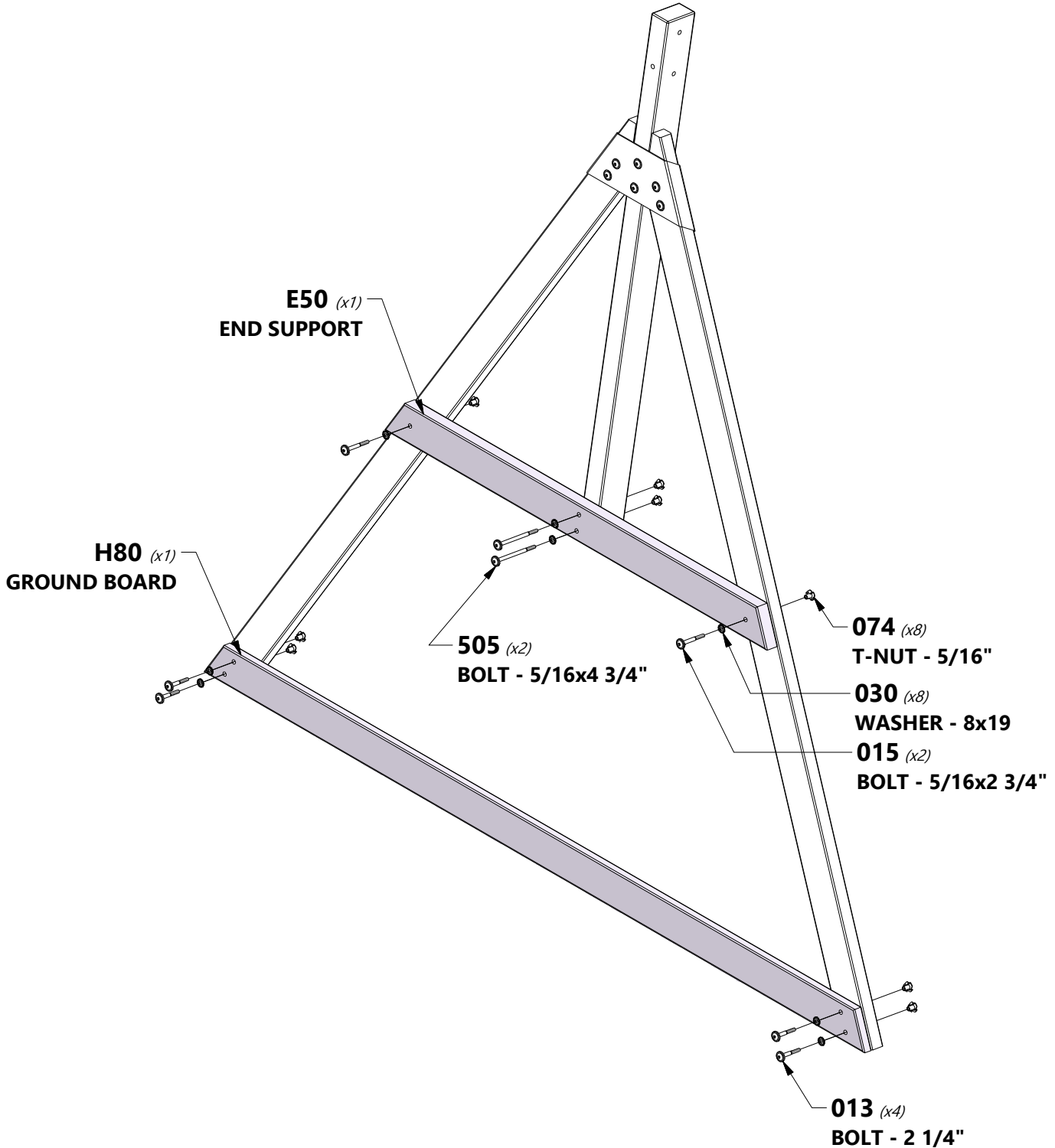

STEP 6 - SWING BEAM ASSEMBLY

QTY	PART NUMBER	DESCRIPTION
5	H100005	NUT BARREL WH 5/16x7/8
1	H100006	NUT BARREL WH 5/16x1 1/2
5	H100011	BOLT WH 5/16x1 3/4
1	H100014	BOLT WH 5/16x2 1/2

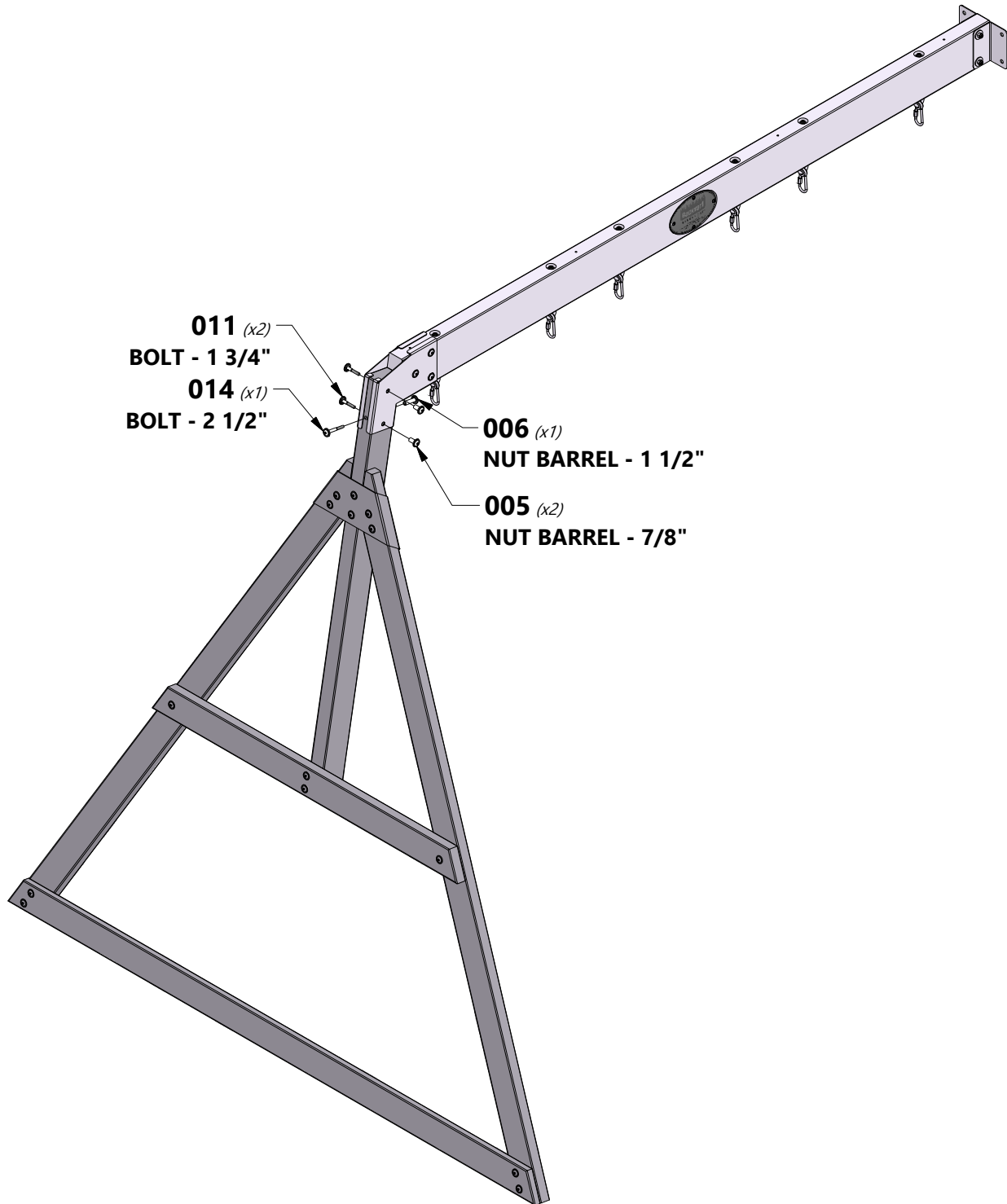

STEP 1 - FORT ASSEMBLY

QTY	PART NUMBER	DESCRIPTION
8	H100012	BOLT WH 5/16x2
4	H100017	BOLT WH 5/16x3 1/4
2	H100026	LAG SCREW WH 5/16x1 1/2
14	H100030	WASHER LOCK EXT 8x19
14	H100074	T-NUT 5/16



E3 | TOWER LEG W/TAG - W2A03400
(x1) | 1 3/8"x3 3/8"x74" (36x86x1880)

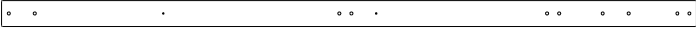

E1 | TOWER LEG - W4L16280
(x1) | 1 3/8"x3 3/8"x90 1/2" (36x86x2298)

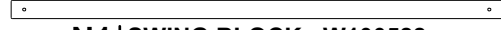

N1 | SWING BLOCK - W100588
(x1) | 5/8"x2 3/8"x63 7/8" (16x60x1624)



K1 | BASE BOARD - W100562
(x1) | 5/8"x5 1/4"x63 7/8" (16x134x1624)



H1 | LEFT FLOOR RAIL - W100557
(x1) | 1"x3 3/8"x63 7/8" (24x86x1624)



L1 | LEFT WALL RAIL - W102360
(x1) | 5/8"x4 3/8"x63 7/8" (16x112x1624)



H5 | FLOOR SUPPORT - W100598
(x2) | 1"x3 3/8"x3 3/8" (24x86x86)

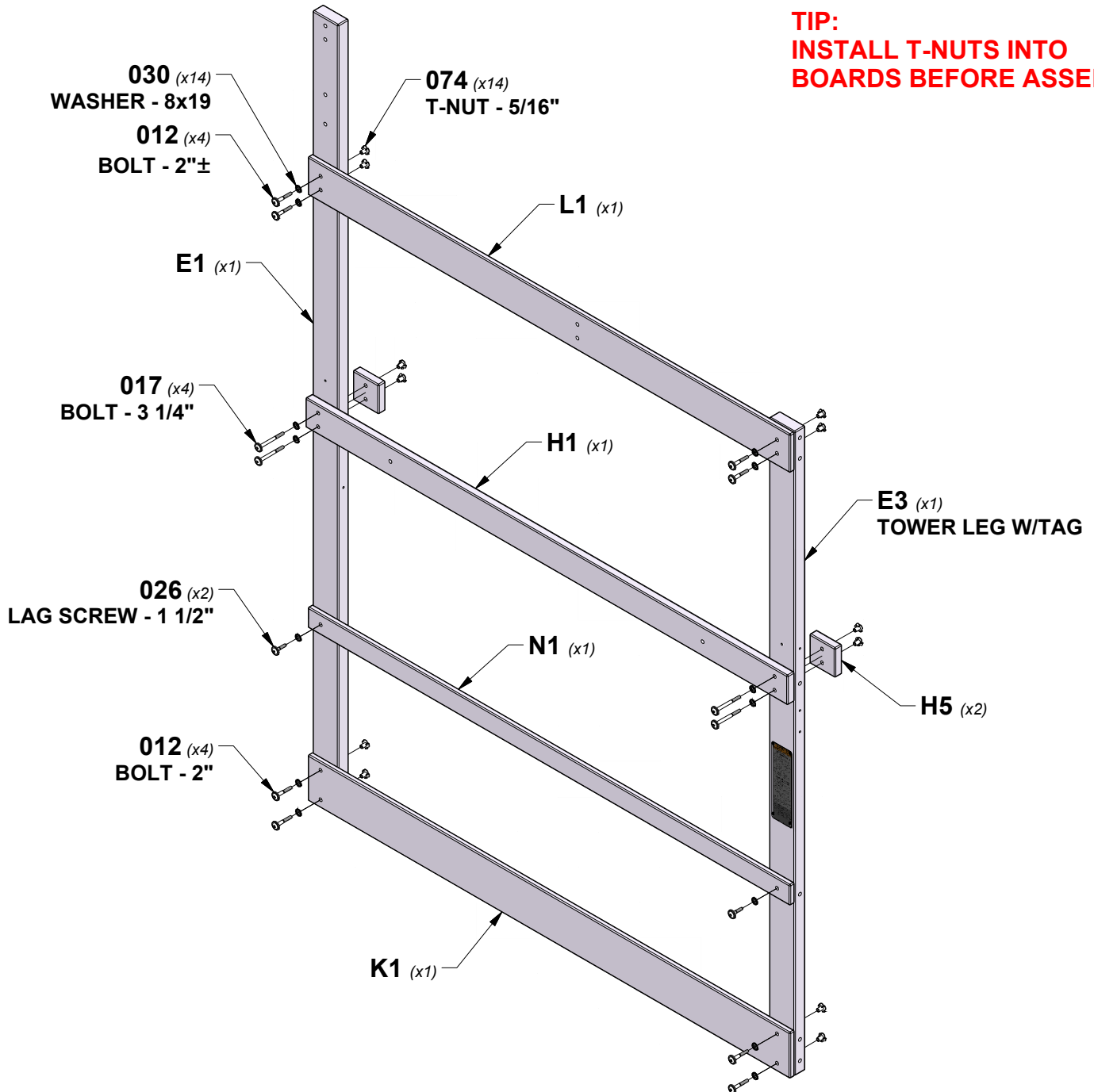

TIP:
INSTALL T-NUTS INTO
BOARDS BEFORE ASSEMBLY

STEP 2 - FORT ASSEMBLY

QTY	PART NUMBER	DESCRIPTION
8	H100012	BOLT WH 5/16x2
4	H100017	BOLT WH 5/16x3 1/4
12	H100030	WASHER LOCK EXT 8x19
12	H100074	T-NUT 5/16



L2 | RIGHT WALL RAIL - W100567
(x1) | 5/8"x4 3/8"x63 7/8" (16x112x1624)



H5 | FLOOR SUPPORT - W100598
(x2) | 1"x3 3/8"x3 3/8" (24x86x86)



K1 | BASE BOARD - W100562
(x1) | 5/8"x5 1/4"x63 7/8" (16x134x1624)

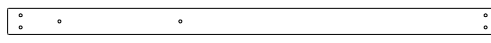

H2 | RIGHT FLOOR RAIL - W4L16276
(x1) | 1"x3 3/8"x63 7/8" (24x86x1624)

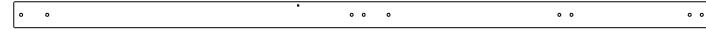

E2 | TOWER LEG - W4L16279
(x1) | 1 3/8"x3 3/8"x90 1/2" (36x86x2298)



E6 | TOWER LEG - W4L16278
(x1) | 1 3/8"x3 3/8"x74" (36x86x1880)

TIP:
INSTALL T-NUTS INTO
BOARDS BEFORE ASSEMBLY

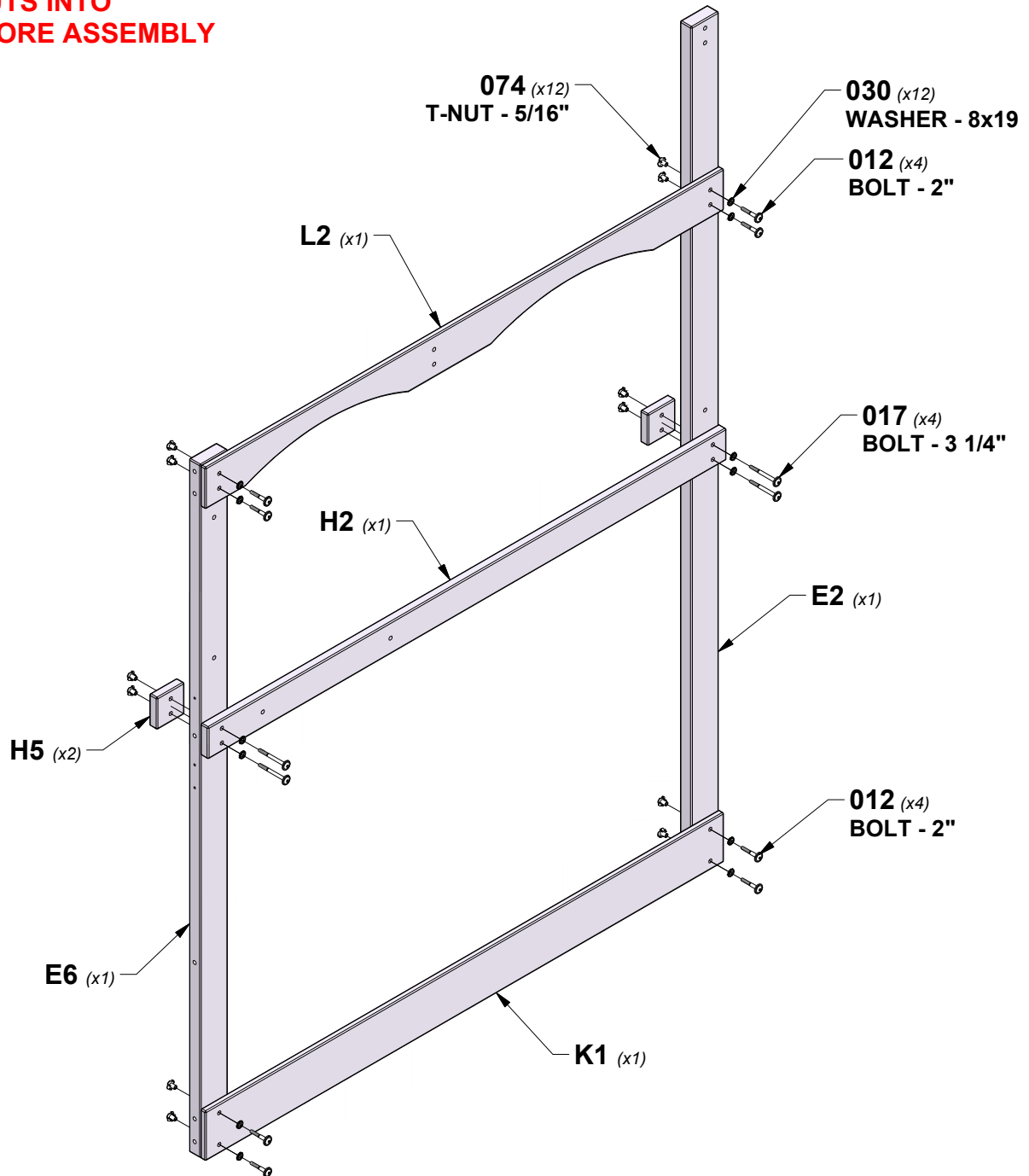

STEP 3 - FORT ASSEMBLY

QTY	PART NUMBER	DESCRIPTION
18	H100020	BOLT WH 5/16x4
4	H100027	LAG SCREW WH 5/16x2
4	H100028	LAG SCREW WH 5/16x2 1/2
26	H100030	WASHER LOCK EXT 8x19
18	H100074	T-NUT 5/16

M8 | WALL RAIL - W100580
(x1) | 5/8"x3 3/8"x40" (16x86x1016)

L3 | WALL RAIL - W100568
(x1) | 5/8"x4 3/8"x40" (16x112x1016)

K3 | FRONT ARCH - W100564
(x1) | 5/8"x5 1/4"x40" (16x134x1016)

M8 | WALL RAIL - W100580
(x2) | 5/8"x3 3/8"x40" (16x86x1016)

L8 | CLUB HOUSE WALL RAIL - W100569
(x1) | 5/8"x4 3/8"x40" (16x112x1016)

K2 | BASE BOARD - W100563
(x2) | 5/8"x5 1/4"x40" (16x134x1016)

TIP:
INSTALL T-NUTS INTO
BOARDS BEFORE ASSEMBLY

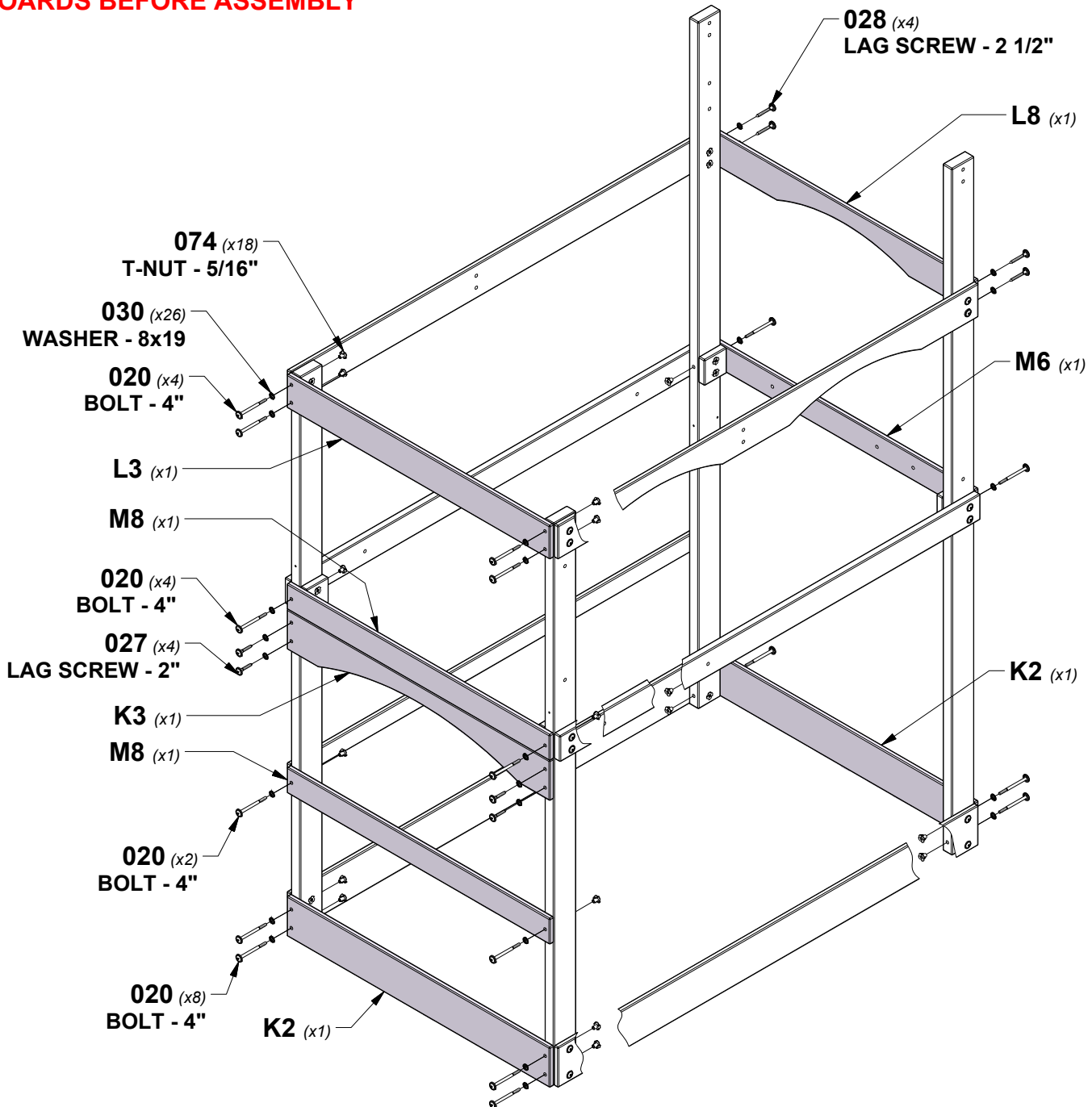

STEP 4 - FORT ASSEMBLY

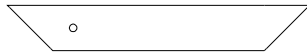

J1 | DECK BRACE - W100561
(x4) | 1"x2 3/8"x15 3/4" (24x60x400)



A100314 | "A" REVISION TAG
(x1)

QTY	PART NUMBER	DESCRIPTION
1	A100314	"A" REVISION TAG
2	H100010	BOLT WH 5/16x1 1/2
2	H100011	BOLT WH 5/16x1 3/4
4	H100030	WASHER LOCK EXT 8x19
4	H100074	T-NUT 5/16
2	H100128	SCREW PWH 8x5/8
4	H100138	WASHER LOCK EXT 6x15
4	H100146	LAG SCREW WH 1/4x2

TIP:
INSTALL T-NUTS INTO
BOARDS BEFORE ASSEMBLY

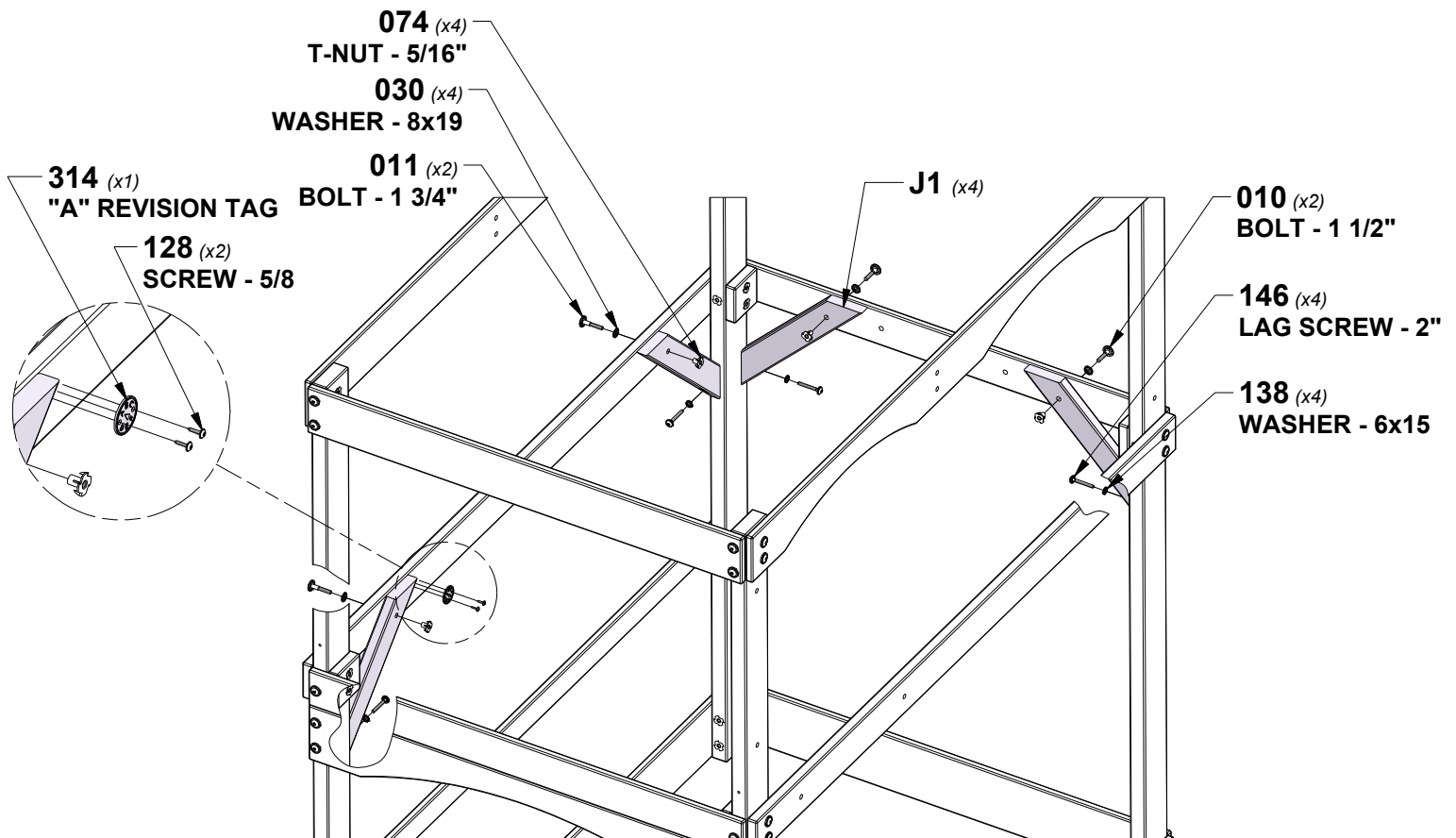

STEP 5 - FORT ASSEMBLY

QTY	PART NUMBER	DESCRIPTION
86	H100111	SCREW PFH 8x2



L5 FLOOR BOARD - W100570
(x2) 5/8"x4 3/8"x37 1/8" (16x112x942)



M3 FLOOR BOARD - W100575
(x16) 5/8"x3 3/8"x41 7/8" (16x86x1064)



N2 FLOOR BOARD - W100589
(x1) 5/8"x2 3/8"x41 7/8" (16x60x1064)

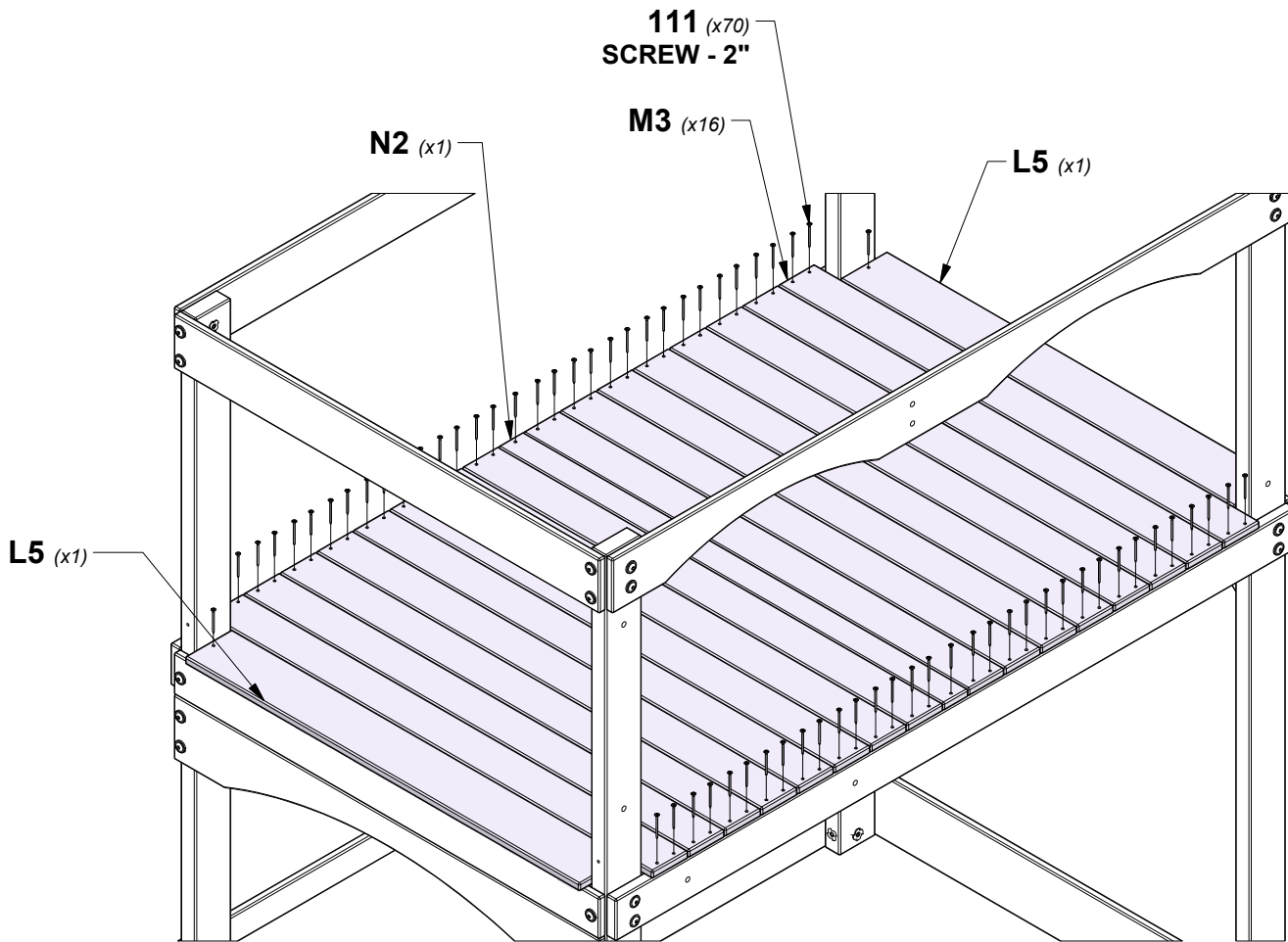

STEP 6 - FORT ASSEMBLY

QTY	PART NUMBER	DESCRIPTION
4	H100083	SCREW TAPPING 14x3/4
17	H100088	SCREW PFH 8x1-1/8"

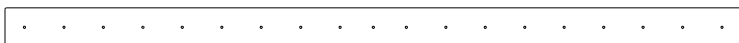

M2 | FLOOR RUNNER - W100574
(x1) | 5/8"x3 3/8"x63 7/8" (16x86x1624)

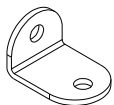

A100061 | L BRACKET GREEN 32x51
(x2)

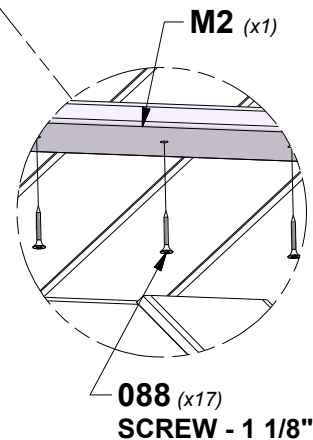
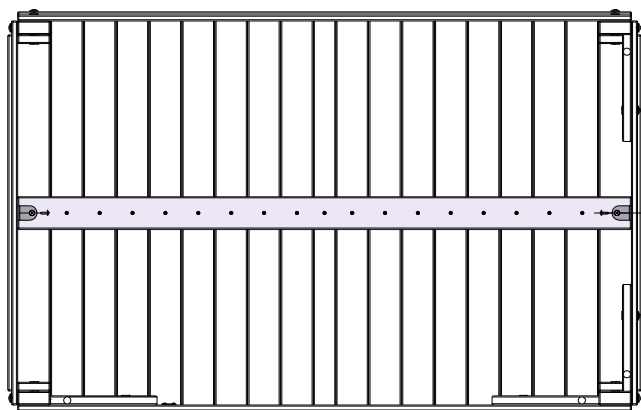
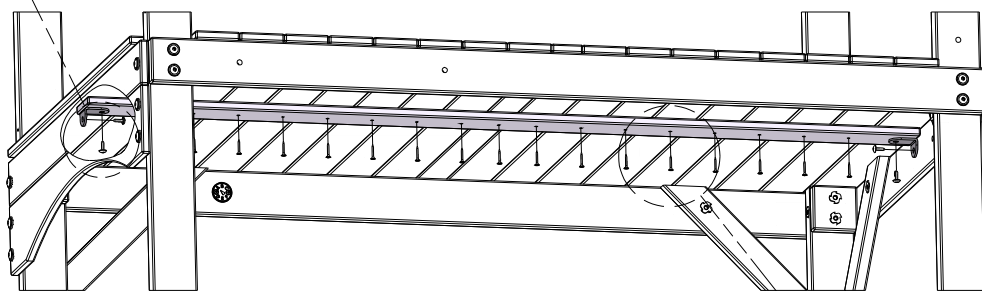
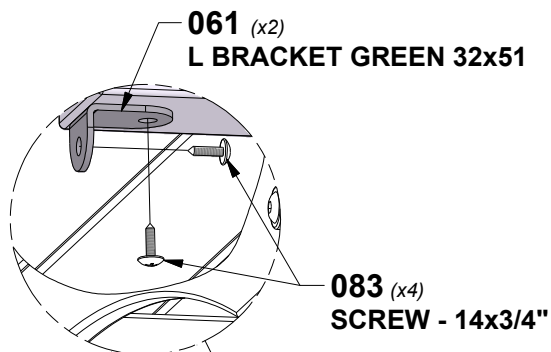

TIP:
CENTER 'M2' FLOOR RUNNER
BOARD ON BOTTOM OF FLOOR

BOTTOM VIEW

STEP 7 - FORT ASSEMBLY

QTY	PART NUMBER	DESCRIPTION
6	H100009	BOLT WH 5/16x1 1/4
93	H100030	WASHER LOCK EXT 8x19
79	H100074	T-NUT 5/16

TIP:
INSTALL T-NUTS INTO
BOARDS BEFORE ASSEMBLY

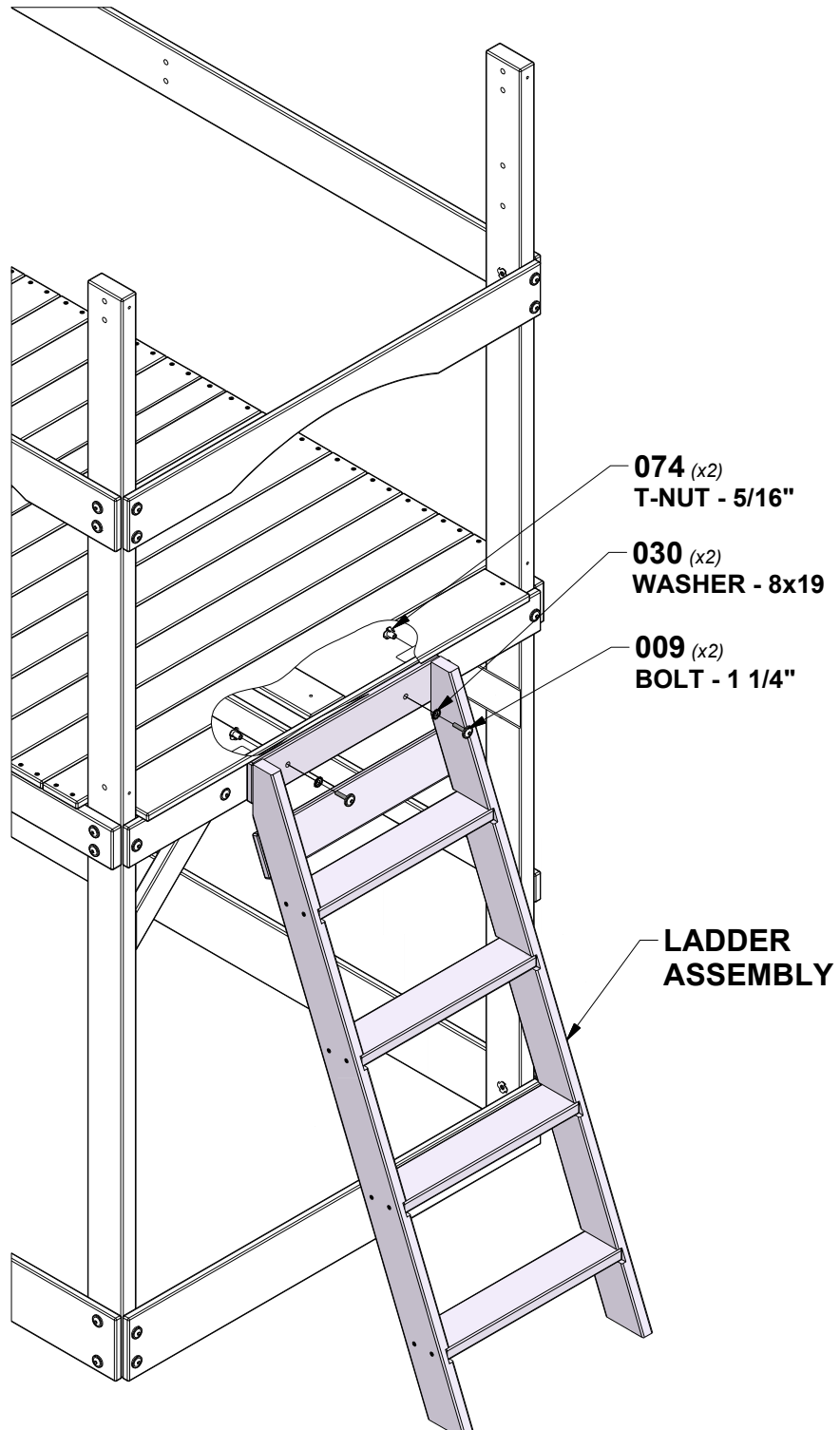

STEP 8 - FORT ASSEMBLY

QTY	PART NUMBER	DESCRIPTION
1	H100012	BOLT WH 5/16x2
6	H100027	LAG SCREW WH 5/16x2
7	H100030	WASHER LOCK EXT 8x19
1	H100074	T-NUT 5/16



M1 | WALL RAIL - W100573
(x1) | 5/8"x3 3/8"x63 7/8" (16x86x1624)



M8 | WALL RAIL - W100580
(x1) | 5/8"x3 3/8"x40" (16x86x1016)

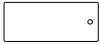

M13 | WALL RAIL - W100585
(x2) | 5/8"x3 3/8"x8 1/4" (16x86x208)



M14 | WALL RAIL - W100586
(x1) | 5/8"x3 3/8"x6 3/4" (16x86x172)

TIP:
INSTALL T-NUTS INTO
BOARDS BEFORE ASSEMBLY

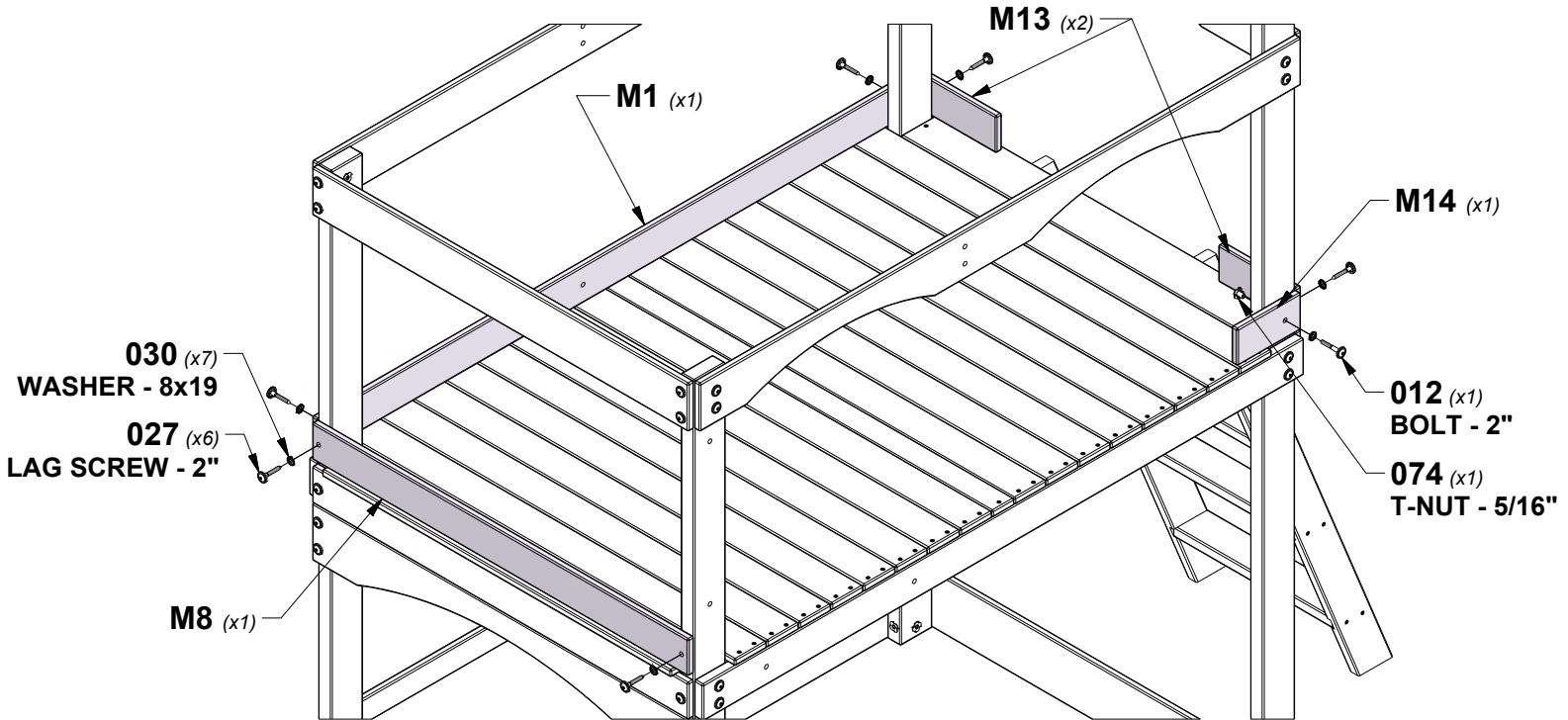

STEP 9 - FORT ASSEMBLY

QTY	PART NUMBER	DESCRIPTION
6	H100012	BOLT WH 5/16x2
2	H100027	LAG SCREW WH 5/16x2
8	H100030	WASHER LOCK EXT 8x19
6	H100074	T-NUT 5/16
2	H100083	SCREW TAPPING 14x3/4



E5 CLUB HOUSE LEG - W102882
(x1) | 1 3/8"x3 3/8"x43 3/8" (36x86x1102)

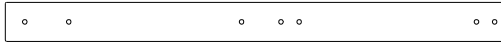

E4 CLUB HOUSE LEG - W102883
(x1) | 1 3/8"x3 3/8"x43 3/8" (36x86x1102)



M13 WALL RAIL - W100585
(x2) | 5/8"x3 3/8"x8 1/4" (16x86x208)

M14 WALL RAIL - W100586
(x1) | 5/8"x3 3/8"x6 3/4" (16x86x172)

TIP:
INSTALL T-NUTS INTO
BOARDS BEFORE ASSEMBLY

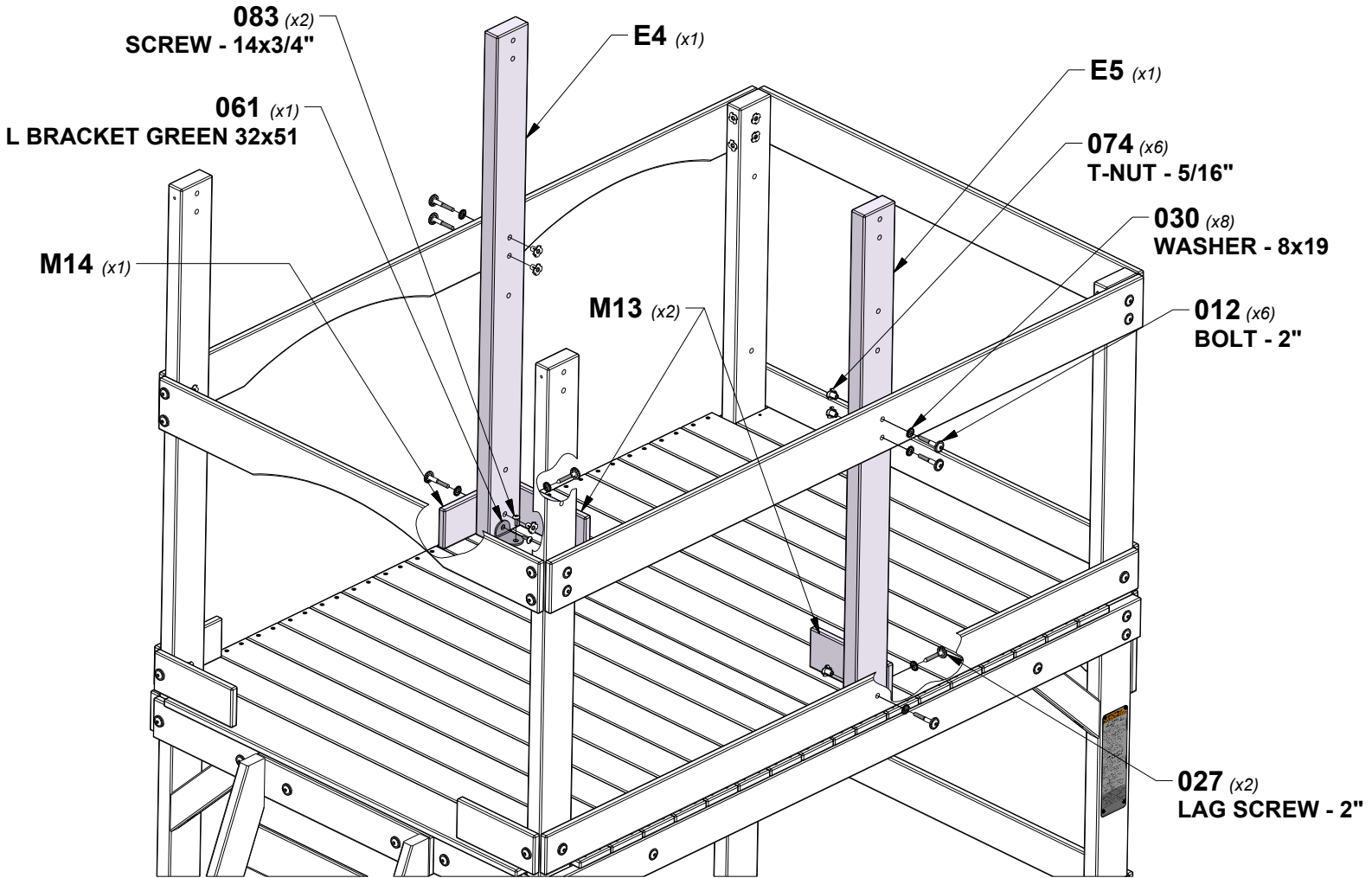

STEP 10 - FORT ASSEMBLY

QTY	PART NUMBER	DESCRIPTION
8	H100012	BOLT WH 5/16x2
4	H100013	BOLT WH 5/16x2 1/4
4	H100027	LAG SCREW WH 5/16x2
16	H100030	WASHER LOCK EXT 8x19
16	H100074	T-NUT 5/16



L8 | CLUB HOUSE WALL RAIL - W100569
(x1) | 5/8"x4 3/8"x40" (16x112x1016)



M9 | WALL RAIL - W100581
(x2) | 5/8"x3 3/8"x37 1/2" (16x86x951)

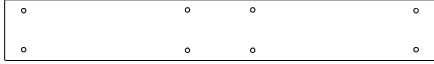

G1 | SWING BEAM MOUNT - W102365
(x1) | 1"x5 1/4"x37 3/8" (24x134x950)

TIP:
INSTALL T-NUTS INTO
BOARDS BEFORE ASSEMBLY

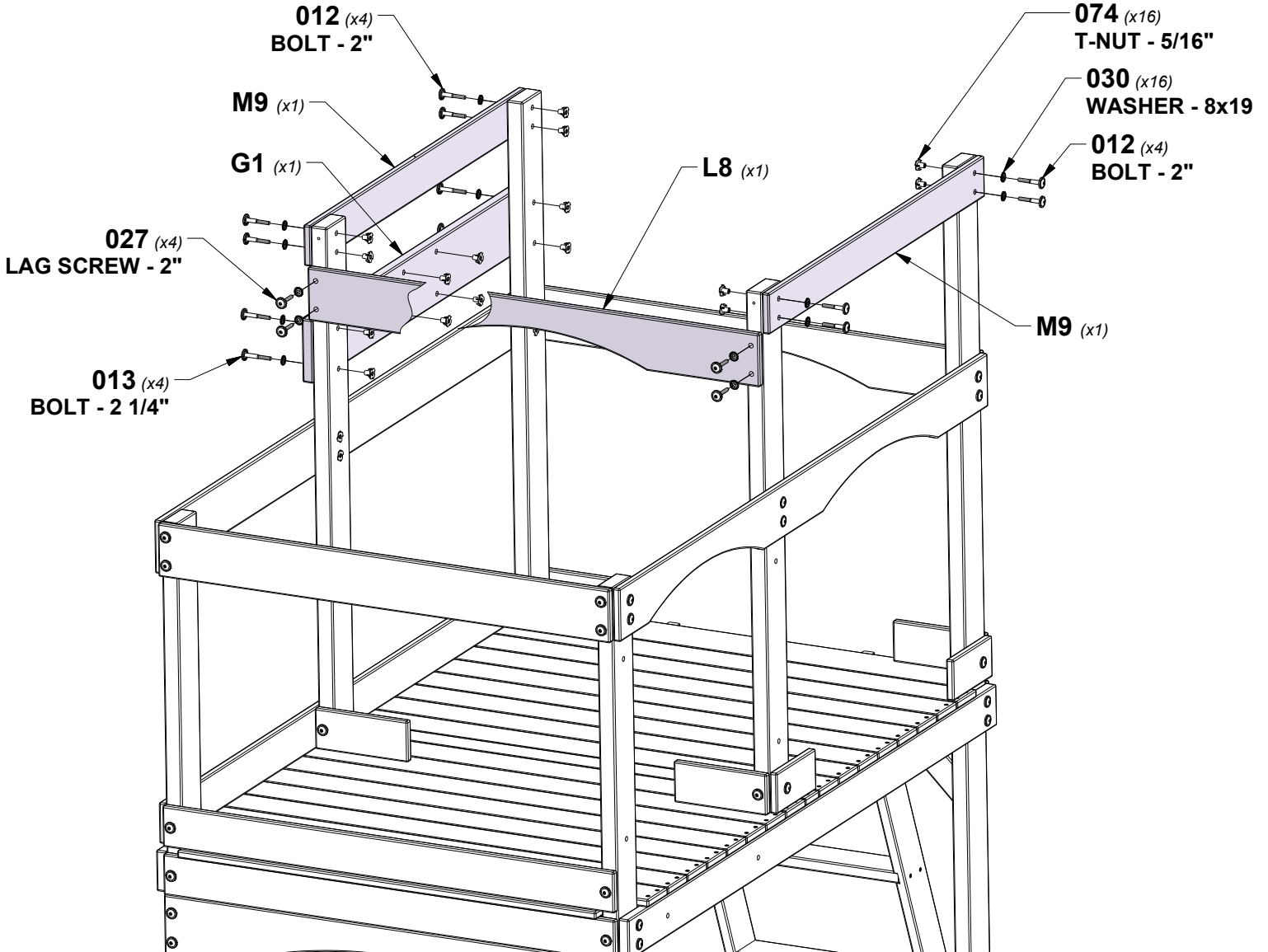

STEP 11 - FORT ASSEMBLY

QTY	PART NUMBER	DESCRIPTION
89	H100087	SCREW PFH 8x1-1/4"

N6 | GABLE BOARD - W100593
(x1) | 5/8"x2 3/8"x13" (16x60x330)

N3 | GABLE BOARD - W100590
(x1) | 5/8"x2 3/8"x31 1/2" (16x60x800)

H3 | ROOF RAFTER - W100559
(x2) | 1"x3 3/8"x34" (24x86x864)

L7 | GABLE MOON - W100572
(x1) | 5/8"x4 3/8"x13" (16x112x330)

N7 | GABLE BOARD - W100594
(x2) | 5/8"x2 3/8"x8" (16x60x202)

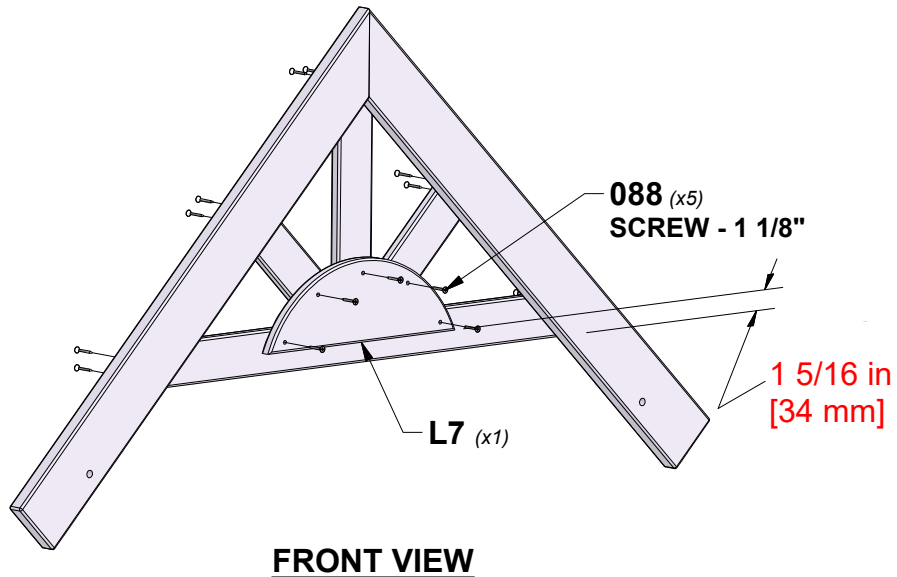
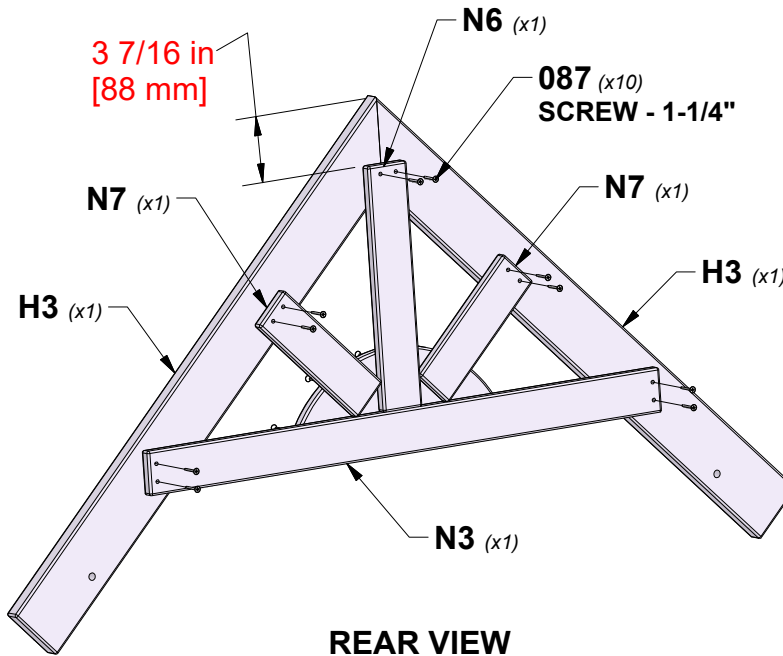

STEP 12 - FORT ASSEMBLY

QTY	PART NUMBER	DESCRIPTION
2	H100028	LAG SCREW WH 5/16x2 1/2
2	H100030	WASHER LOCK EXT 8x19

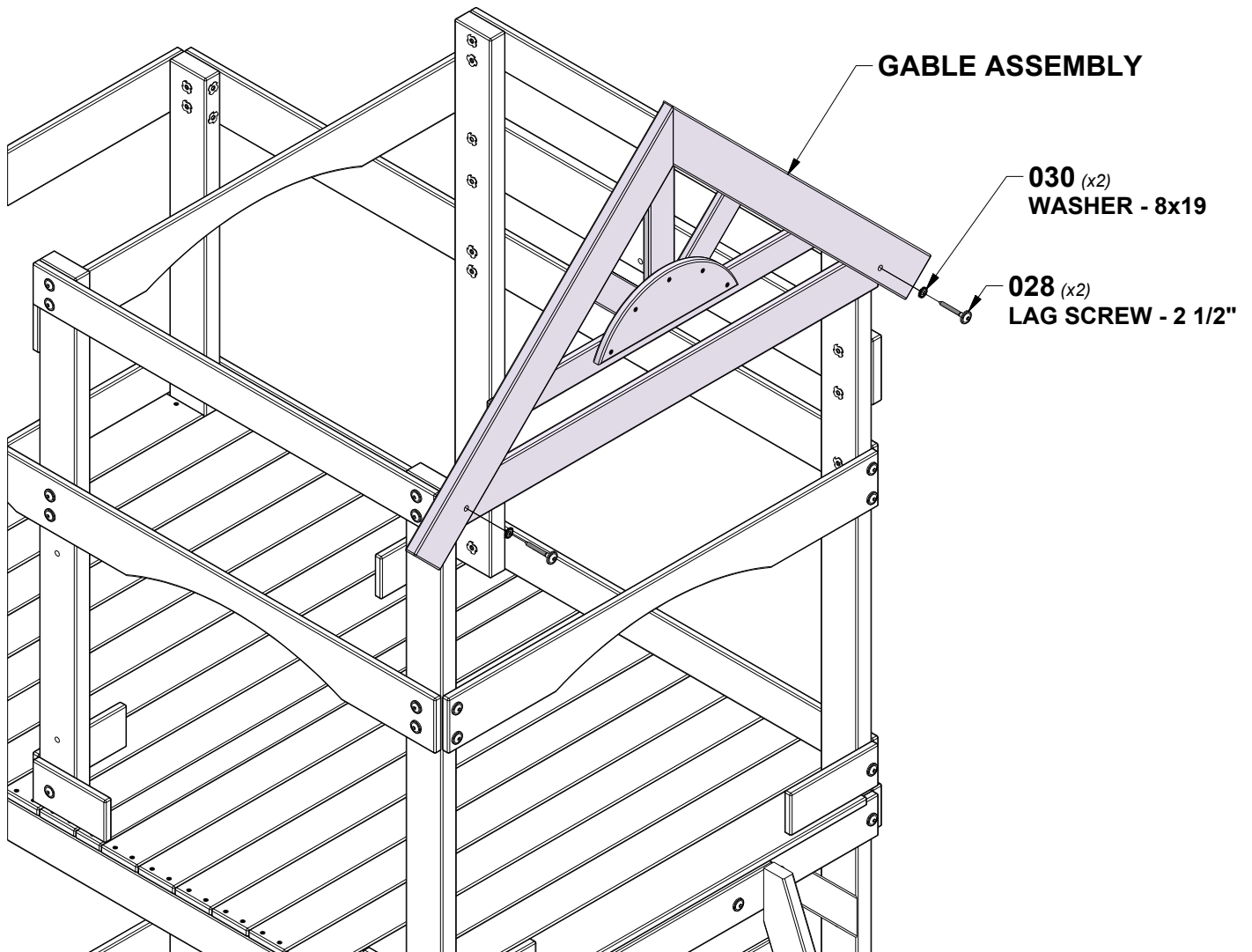

STEP 13 - FORT ASSEMBLY

QTY	PART NUMBER	DESCRIPTION
2	H100028	LAG SCREW WH 5/16x2 1/2
2	H100030	WASHER LOCK EXT 8x19

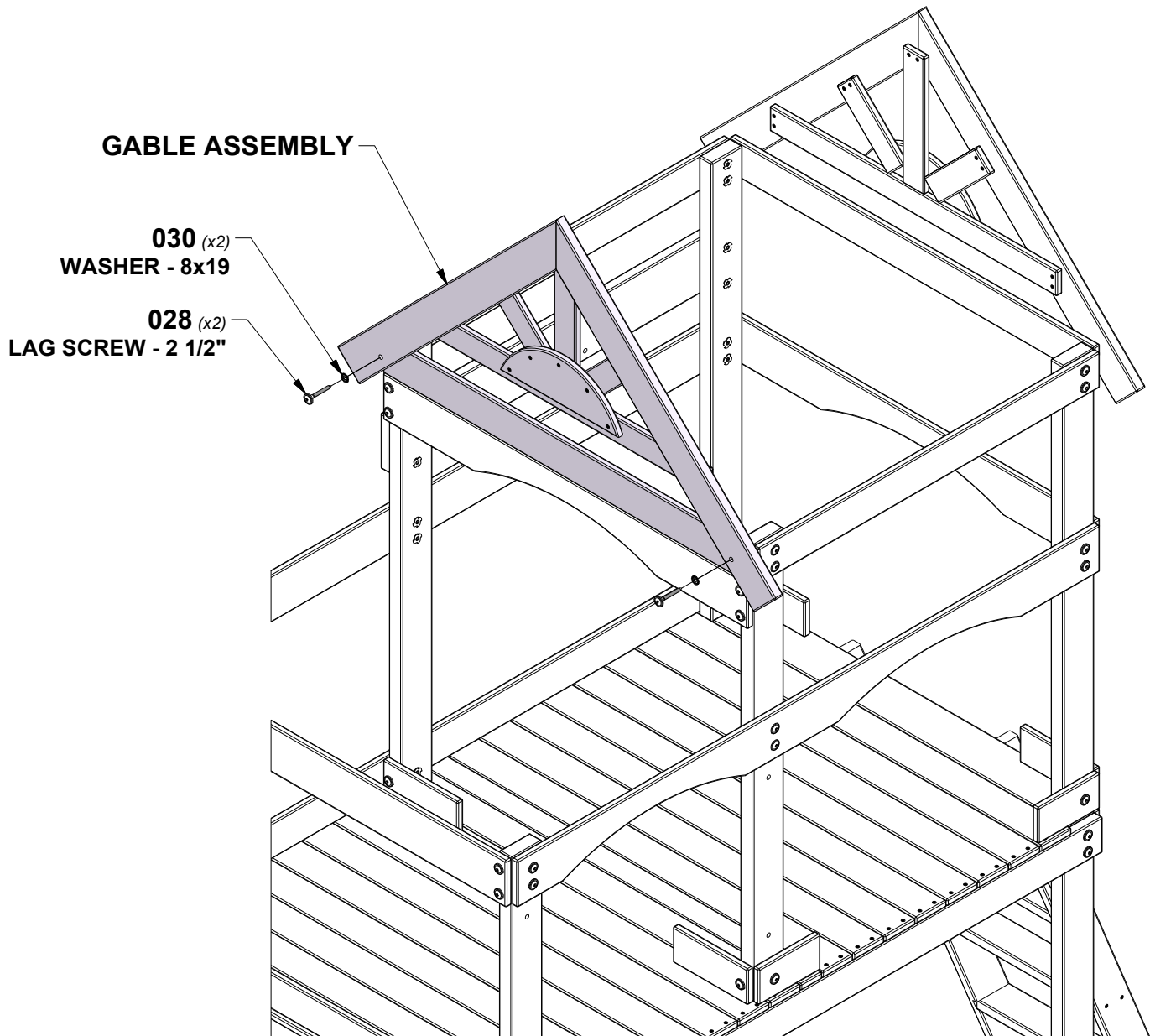

STEP 14 - FORT ASSEMBLY

QTY	PART NUMBER	DESCRIPTION
58	H100088	SCREW PFH 8x1-1/8"

M11 | WALL BOARD - W100583
(x9) | 5/8"x3 3/8"x20" (16x86x508)

N4 | WALL BOARD - W100591
(x6) | 5/8"x2 3/8"x23" (16x60x584)

M7 | WALL BOARD - W100579
(x2) | 5/8"x3 3/8"x40" (16x86x1016)

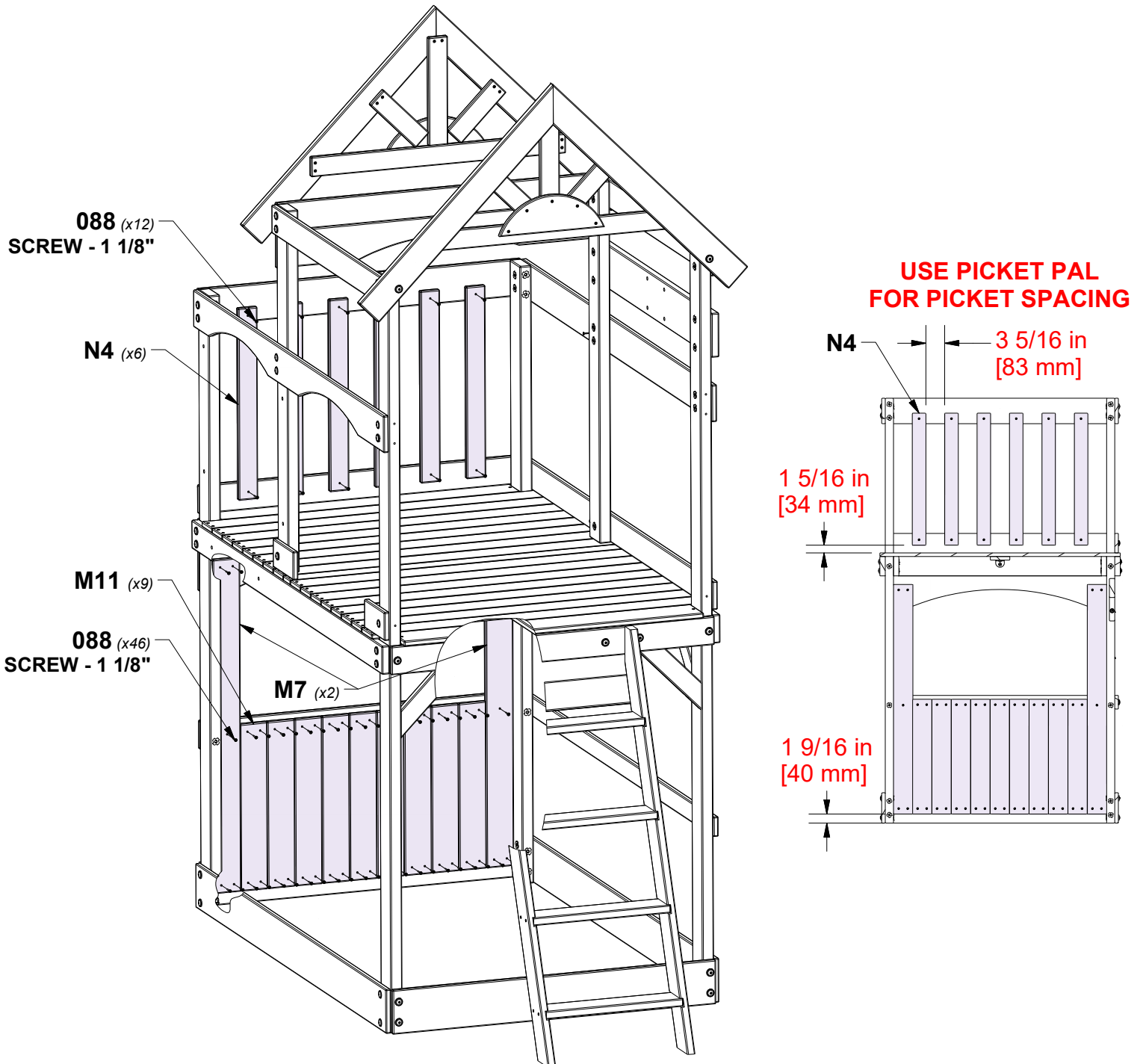

STEP 15 - FORT ASSEMBLY

QTY	PART NUMBER	DESCRIPTION
4	H100083	SCREW TAPPING 14x3/4
20	H100088	SCREW PFH 8x1-1/8"



M5 | WALL BOARD - W100577
(x4) | 5/8"x3 3/8"x42" (16x86x1066)



N8 | WALL BOARD SUPPORT - W100595
(x2) | 5/8"x2 3/8"x6 3/4" (16x60x170)

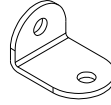

A100061 | L BRACKET GREEN 32x51
(x2)

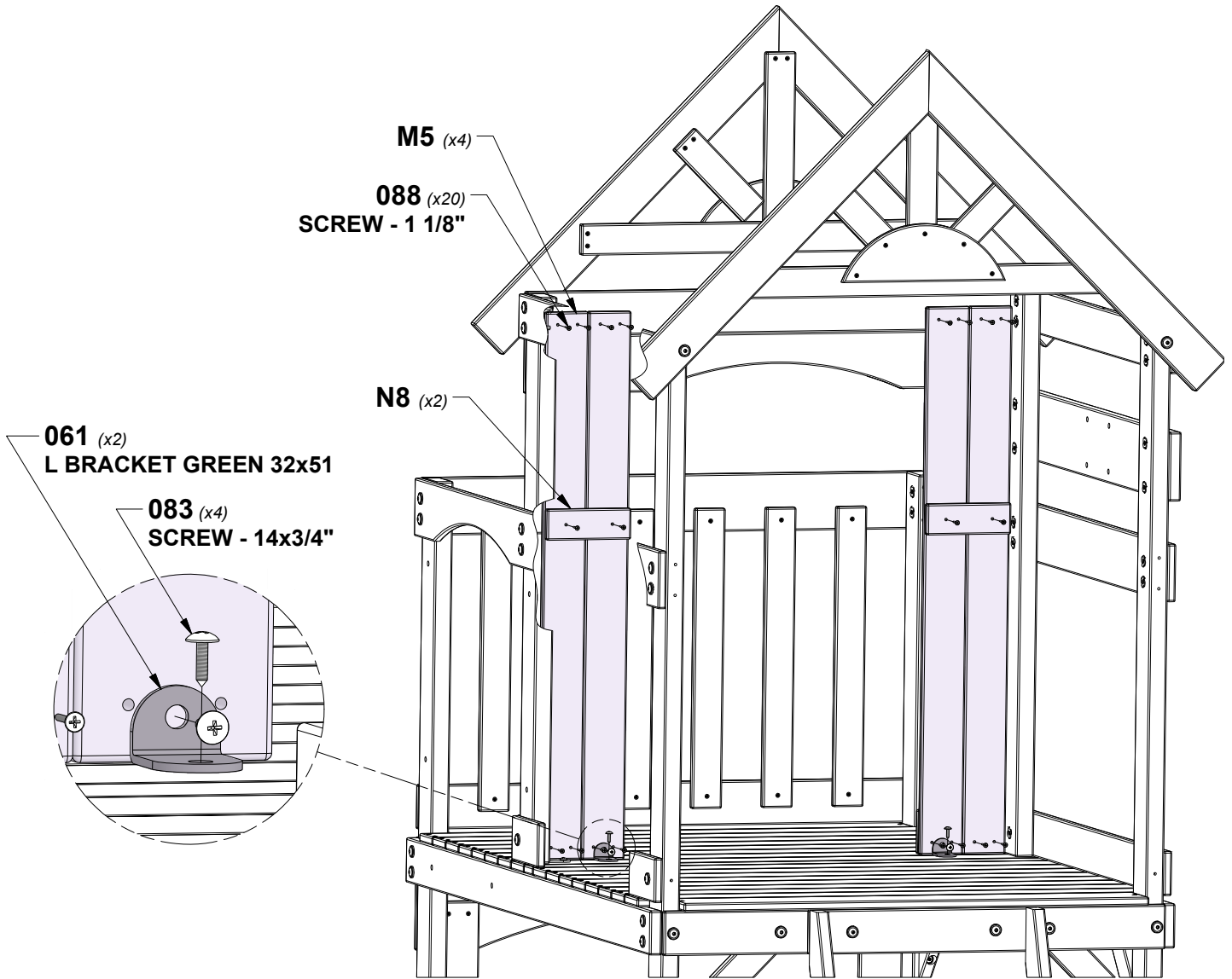

STEP 16 - FORT ASSEMBLY

QTY	PART NUMBER	DESCRIPTION
4	H100083	SCREW TAPPING 14x3/4
48	H100088	SCREW PFH 8x1-1/8"

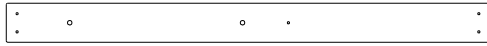

M16 | WALL BOARD - W100599
(x4) | 5/8"x3 3/8"x42" (16x86x1066)



M12 | WALL BOARD - W100584
(x3) | 5/8"x3 3/8"x16 7/8" (16x86x428)



M15 | WALL BOARD - W100587
(x8) | 5/8"x3 3/8"x4 1/8" (16x86x106)

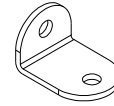

A100061 | L BRACKET GREEN 32x51
(x2)

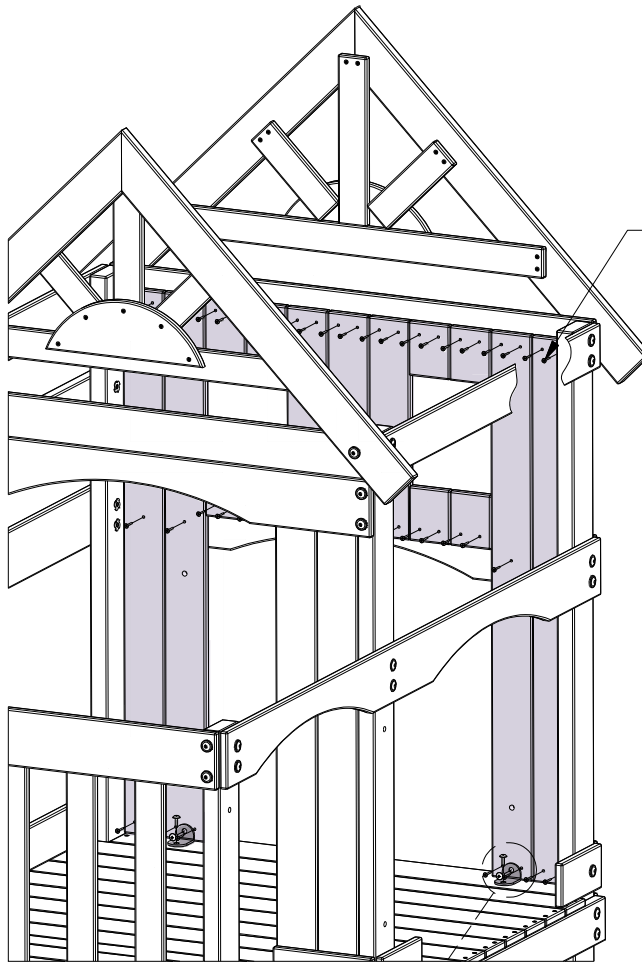

088 (x48)
SCREW - 1 1/8"

TIP:
SPACE BOARDS EVENLY
TO MINIMIZE GAPS.

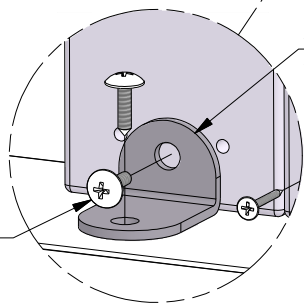
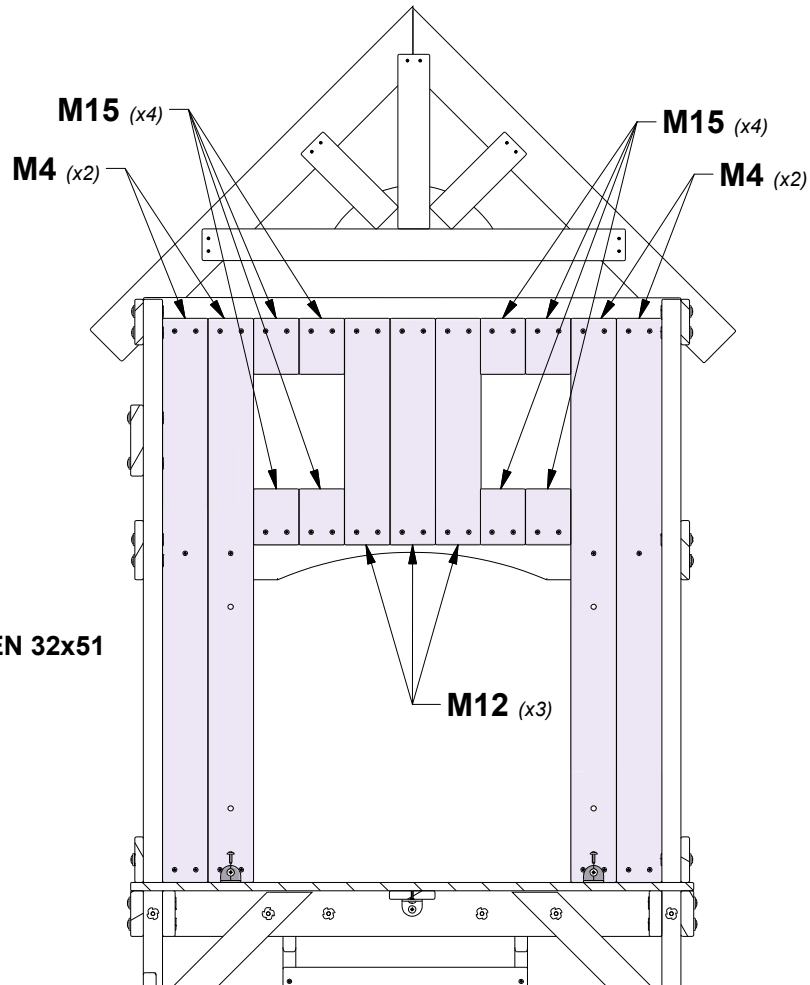

061 (x2)
L BRACKET GREEN 32x51

083 (x4)
SCREW - 14x3/4"

STEP 17 - FORT ASSEMBLY

QTY	PART NUMBER	DESCRIPTION
8	H100070	SCREW PWH 8x3/4

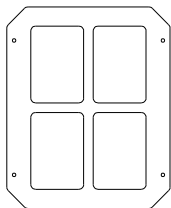

A100146
(x2) | **WINDOW 216x267 GREEN**

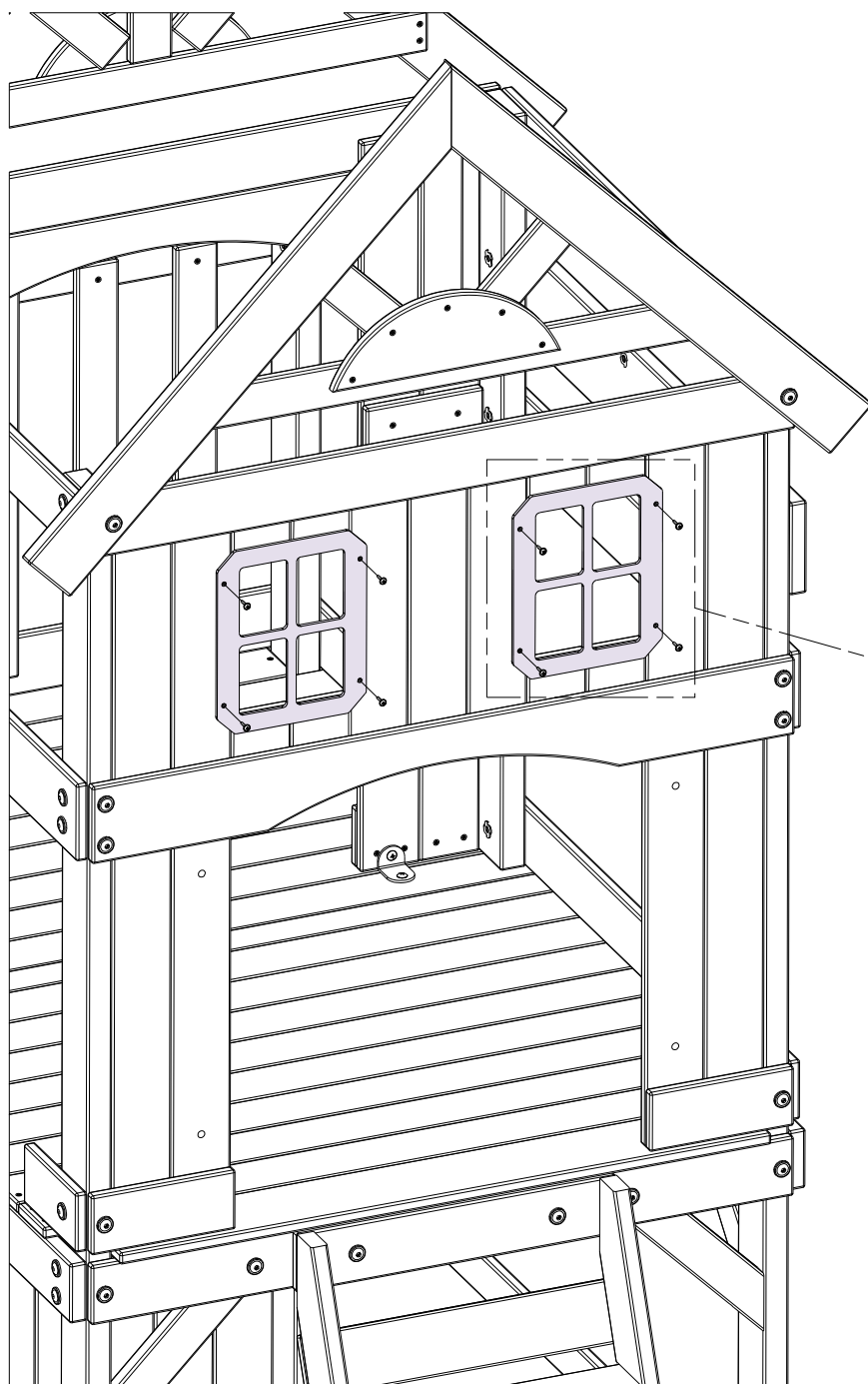

146 (x2)
WINDOW 216x267 GREEN

070 (x8)
SCREW - 8x3/4"

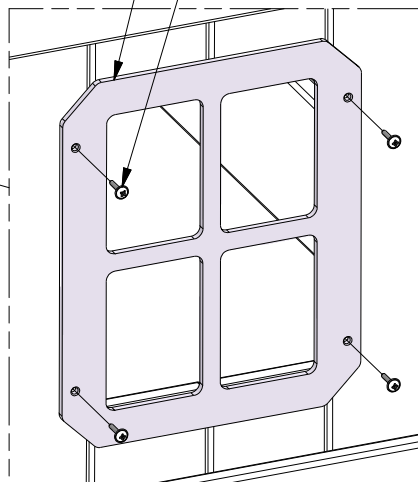

STEP 18 - FORT ASSEMBLY

QTY	PART NUMBER	DESCRIPTION
7	H100087	SCREW PFH 8x1-1/4"

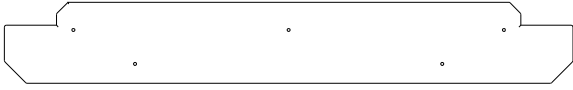

K4 | TABLE TOP - W100565
(x1) | 5/8"x5 1/4"x37" (16x134x940)



H4 | TABLE SUPPORT - W100560
(x2) | 1"x2"x4" (24x51x102)

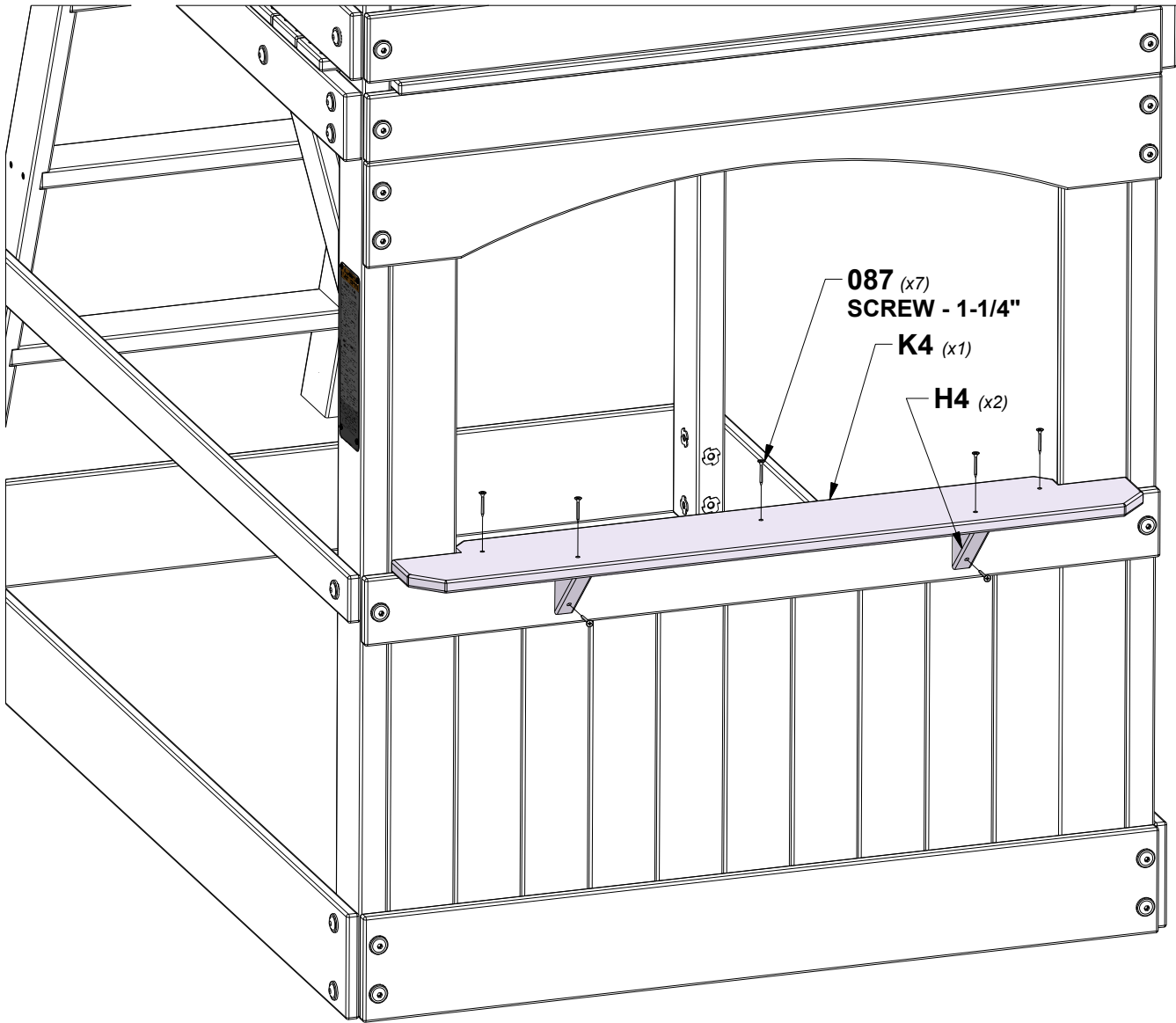

STEP 19 - FORT ASSEMBLY

QTY	PART NUMBER	DESCRIPTION
53	H100088	SCREW PFH 8x1-1/8"



N4 | WALL BOARD - W100591
(x4) | 5/8"x2 3/8"x23" (16x60x584)



M4 | WALL BOARD - W100576
(x9) | 5/8"x3 3/8"x42" (16x86x1066)

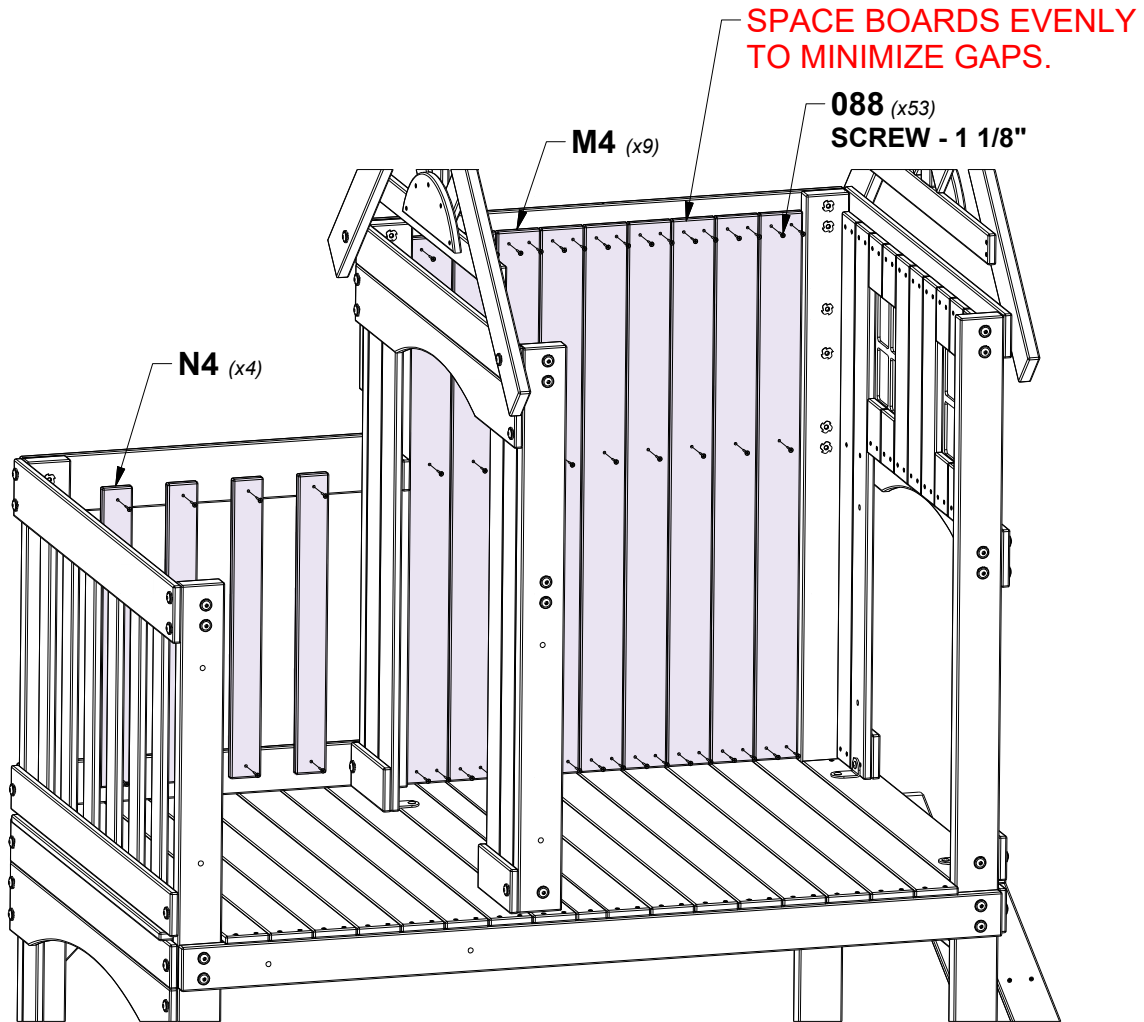

USE PICKET PAL FOR PICKET SPACING

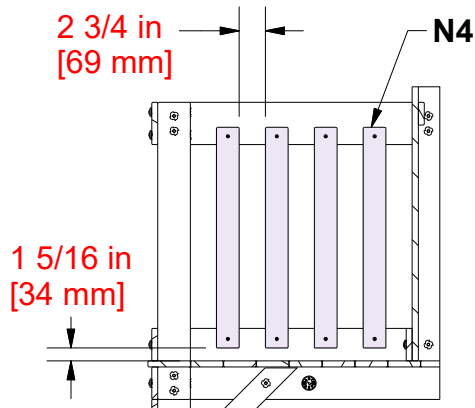

STEP 20 - FORT ASSEMBLY

QTY	PART NUMBER	DESCRIPTION
8	H100088	SCREW PFH 8x1-1/8"



M10 | WALL BOARD - W100582
(x2) | 5/8"x3 3/8"x25" (16x86x634)

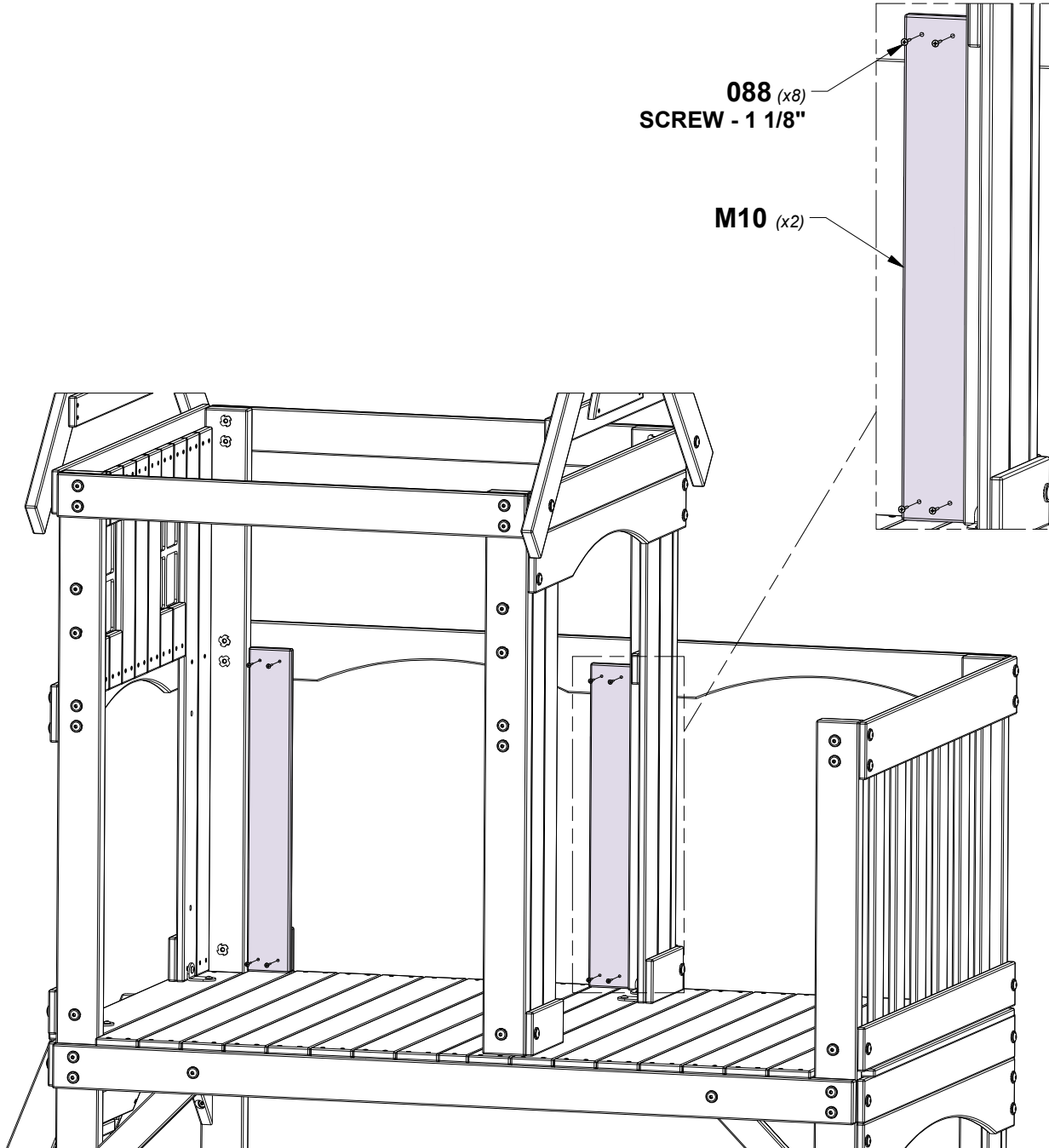

STEP 21 - FORT ASSEMBLY

QTY	PART NUMBER	DESCRIPTION
6	H100087	SCREW PFH 8x1-1/4"

USING BAY WINDOW ASSEMBLY AS A TEMPLATE, DRILL (6) 1/8" [3mm] HOLES THRU 'M9' & 'L2'.

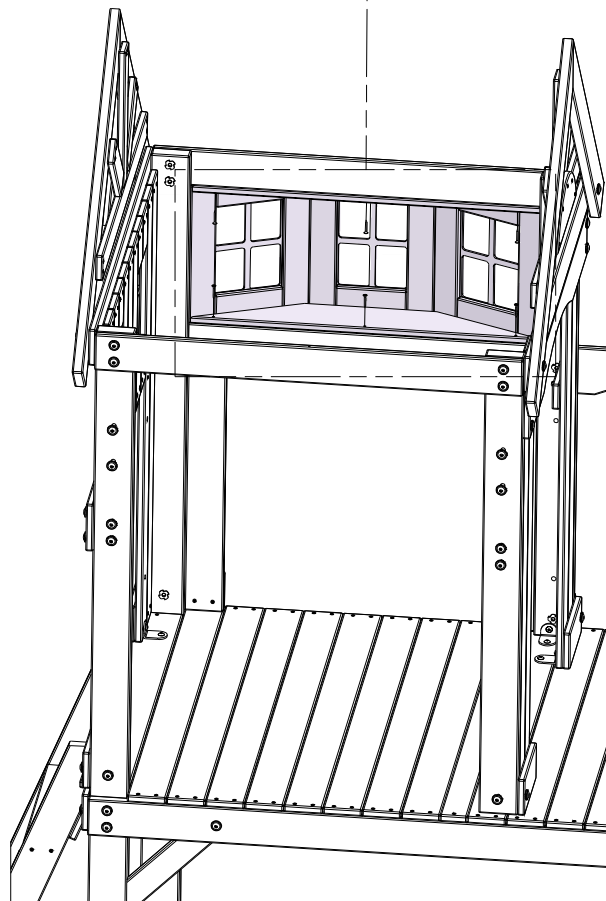
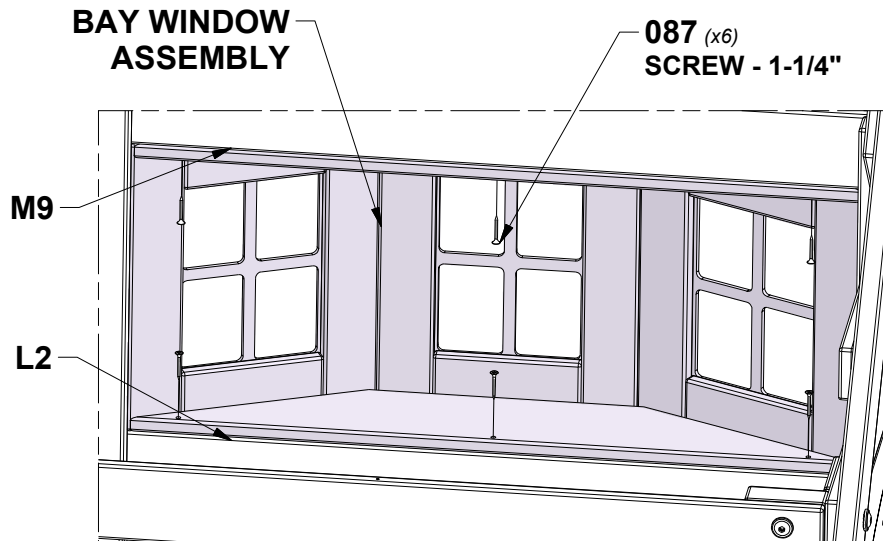

STEP 22 - FORT ASSEMBLY

QTY	PART NUMBER	DESCRIPTION
4	H100009	BOLT WH 5/16x1 1/4
8	H100074	T-NUT 5/16
4	H100115	BOLT WH 5/16x1/2

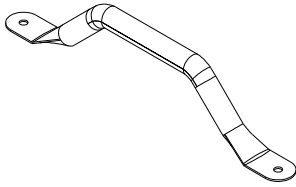

A100118 | HAND GRIP METAL GREEN 381 c/c
(x4)

TIP:
INSTALL T-NUTS INTO
BOARDS BEFORE ASSEMBLY

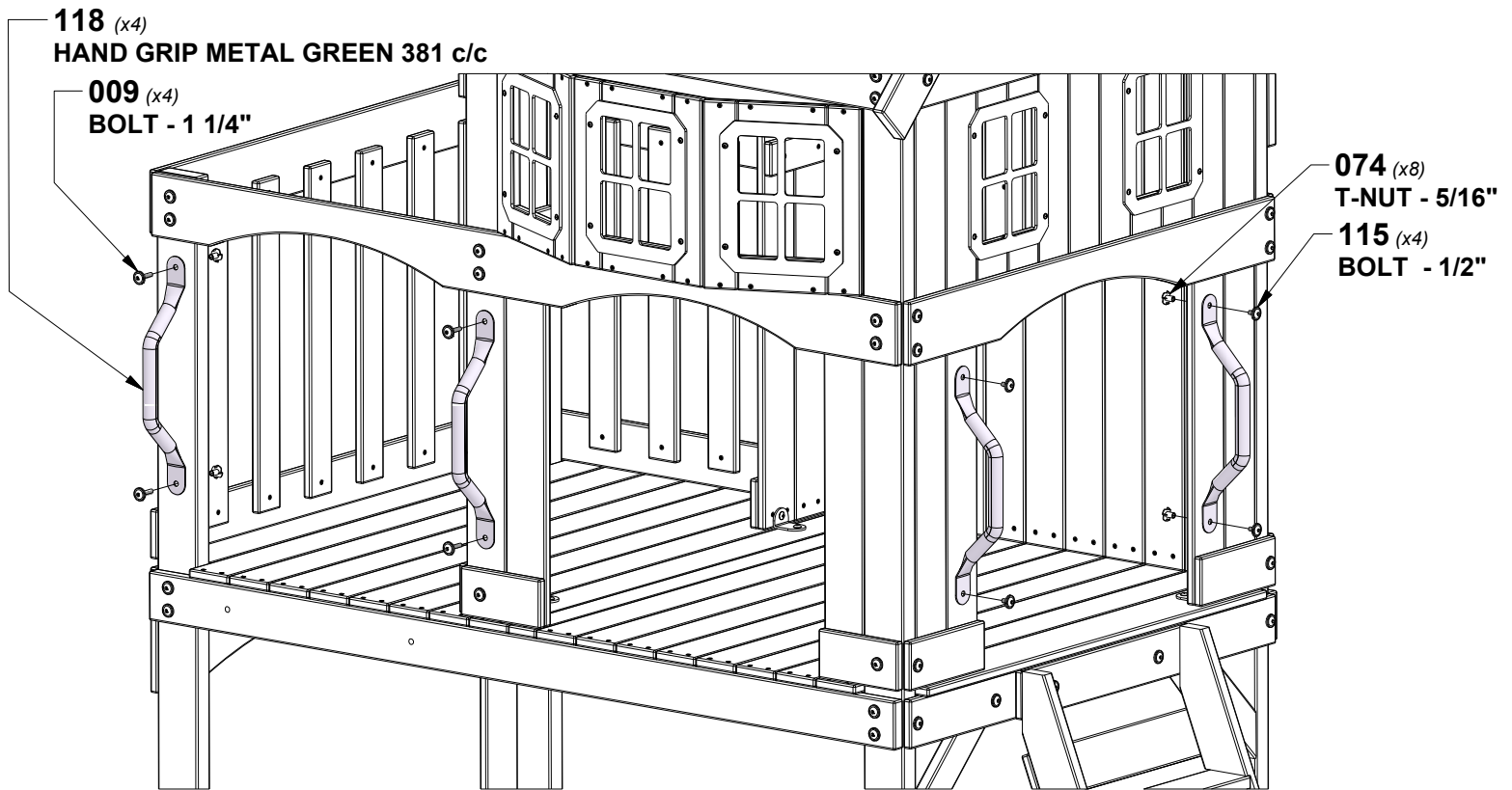

STEP 23 - FORT ASSEMBLY

QTY	PART NUMBER	DESCRIPTION
89	H100087	SCREW PFH 8x1-1/4"



R1 | ROOF BOARD - W100597
(x14) | 3/4"x5 1/2"x42 1/2" (18x140x1080)

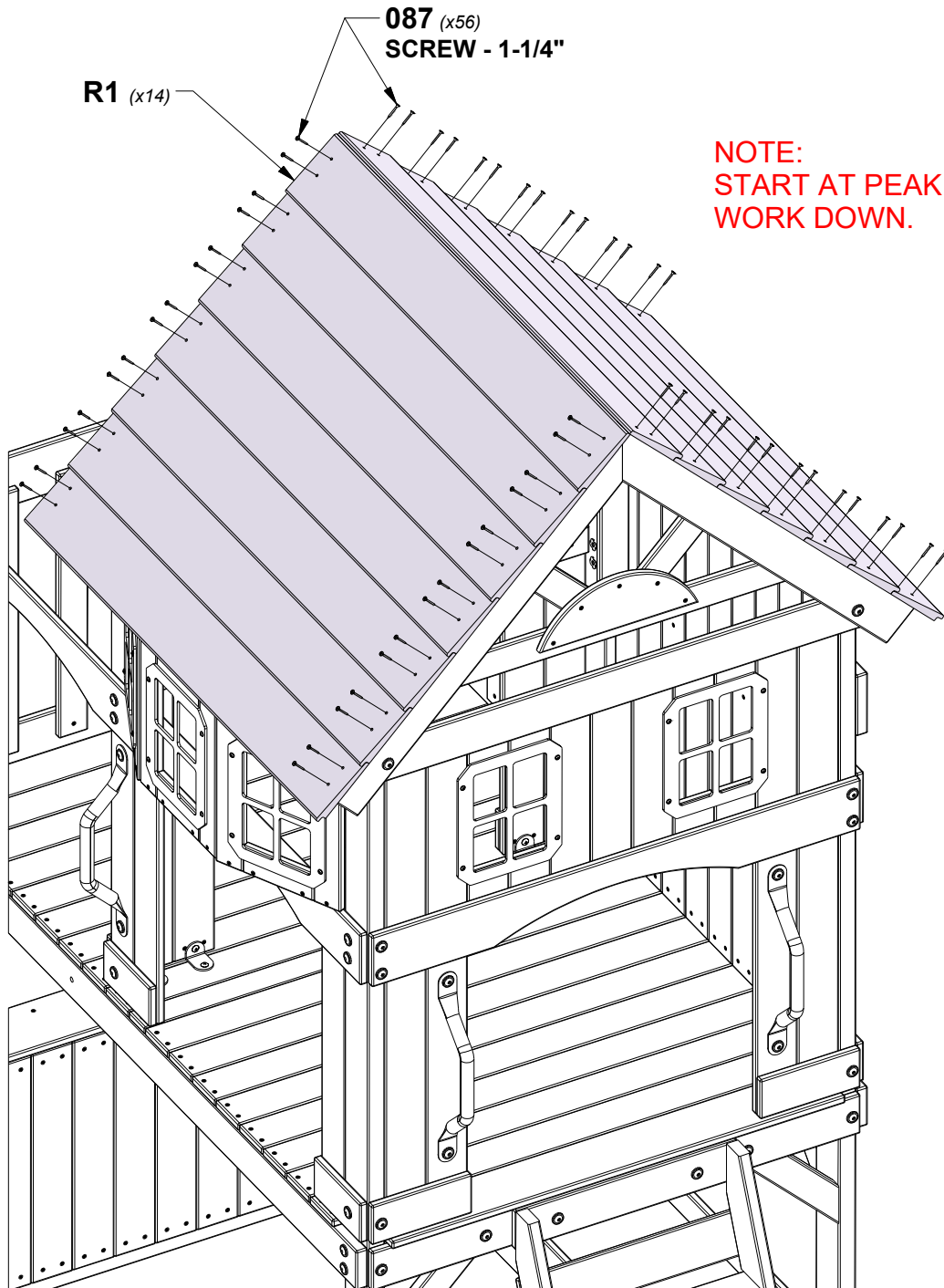

STEP 1 - FINAL ASSEMBLY

QTY	PART NUMBER	DESCRIPTION
2	H100011	BOLT WH 5/16x1 3/4
2	H100030	WASHER LOCK EXT 8x19

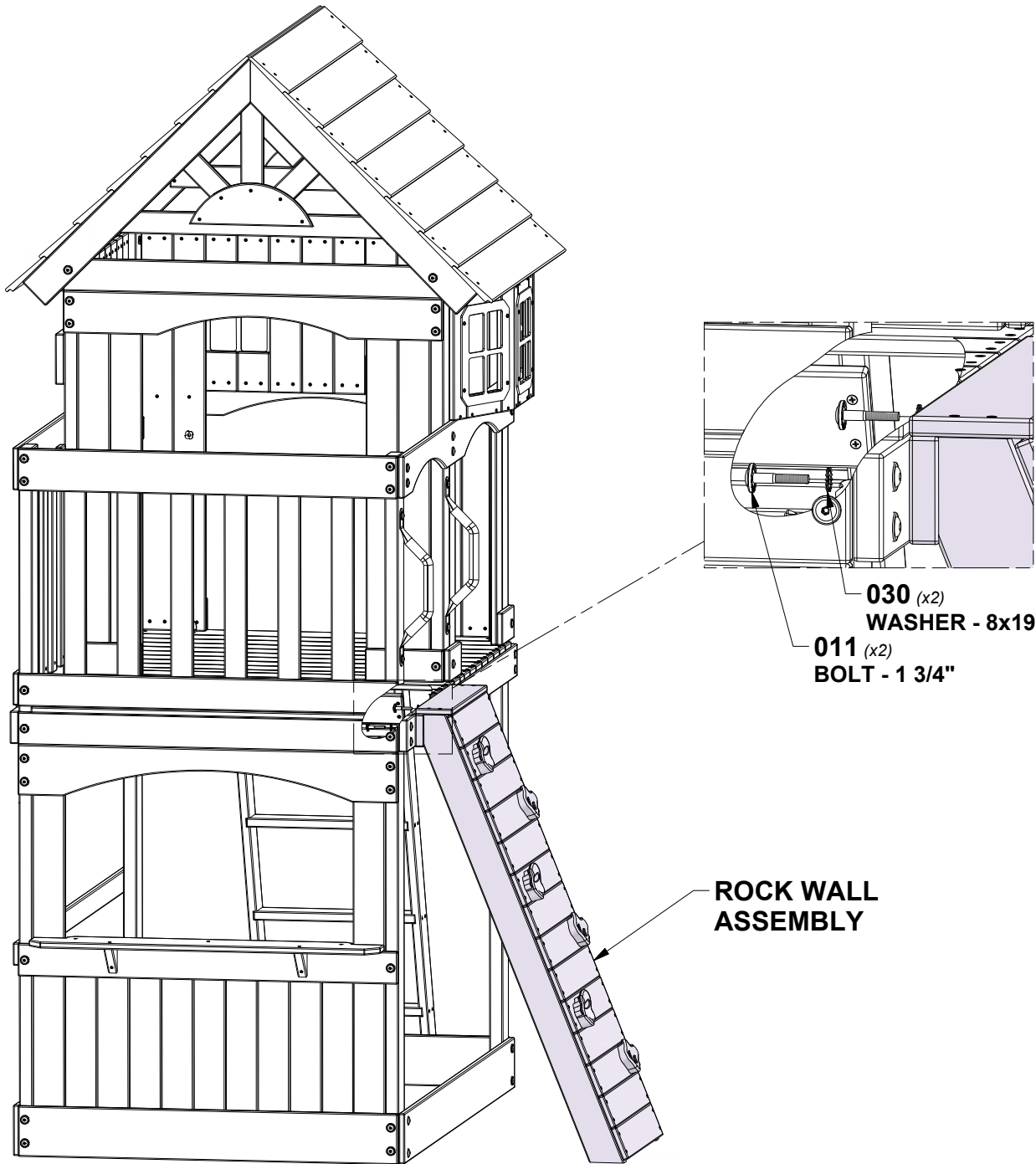

STEP 2 - FINAL ASSEMBLY

QTY	PART NUMBER	DESCRIPTION
3	H100074	T-NUT 5/16
3	H100115	BOLT WH 5/16x1/2

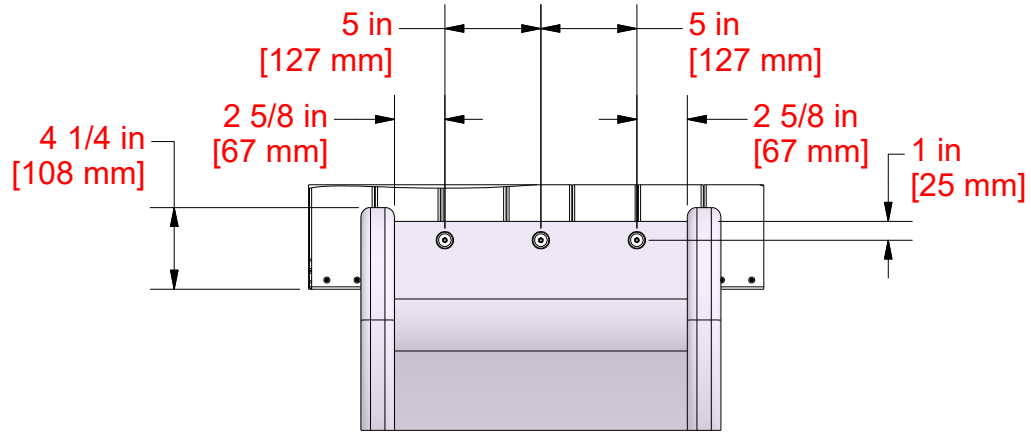

NOTE:
 CENTER SLIDE IN OPENING. USING DIMENSIONS BELOW AS A
 TEMPLATE, DRILL (3) 3/8" [10mm] HOLES THROUGH DECK FOR HARDWARE

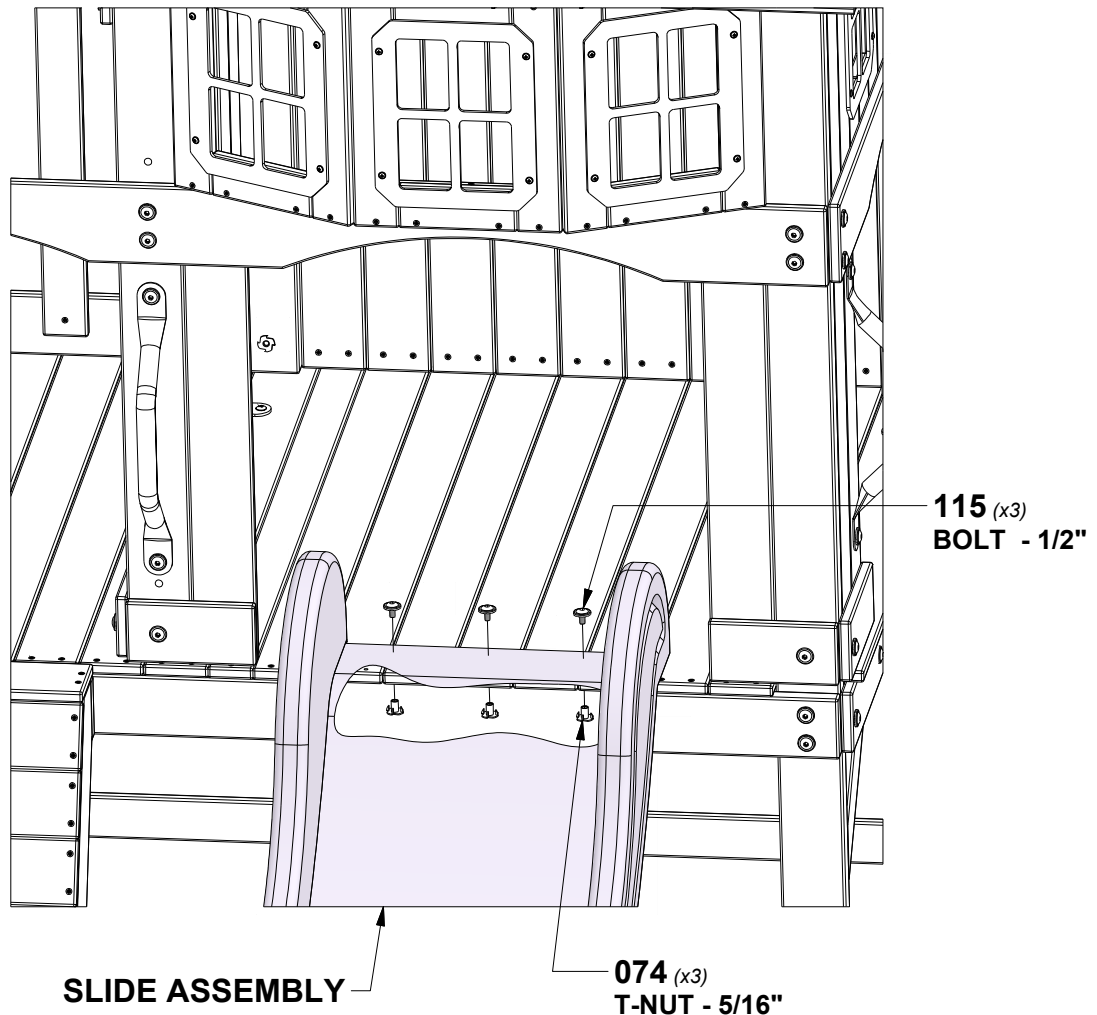

STEP 3 - FINAL ASSEMBLY

QTY	PART NUMBER	DESCRIPTION
4	H100042	BOLT HEX 5/16x1 1/4
4	H100095	WASHER SPLIT 5/16
4	H100105	WASHER FLAT 8x27

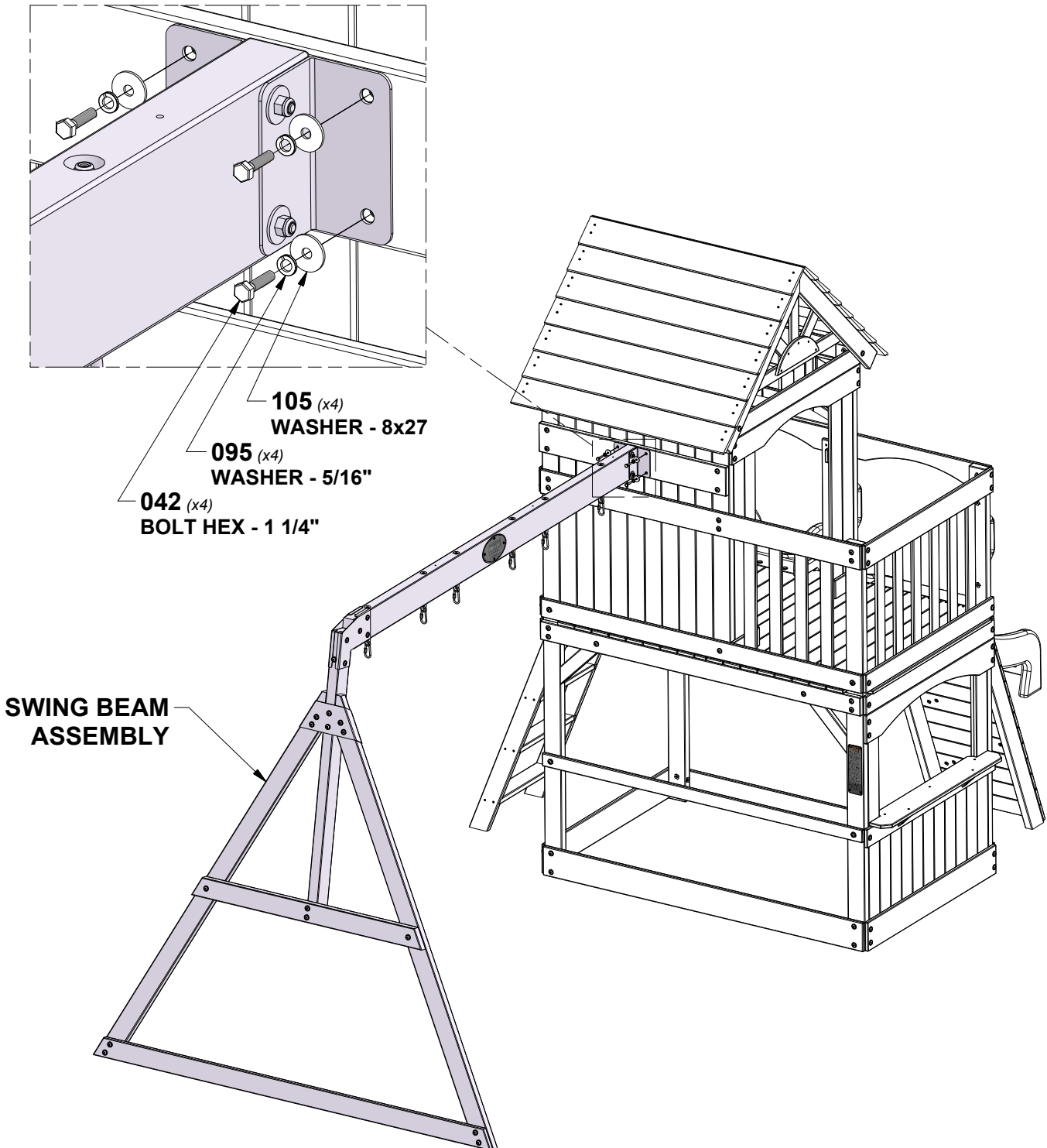

STEP 4 - FINAL ASSEMBLY

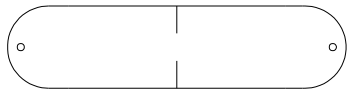

A100171 | SWING SEAT YELLOW 22"
(x2)

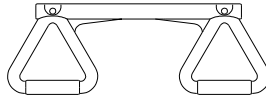

A6P00034 | TRAPEZE YELLOW
(x1)

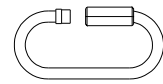

A100069 | QUICK LINK
(x6)



A100087 | ROPE-CHAIN GREEN 51.25"
(x4)

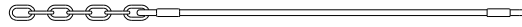

A100083 | ROPE-CHAIN GREEN 33"
(x2)

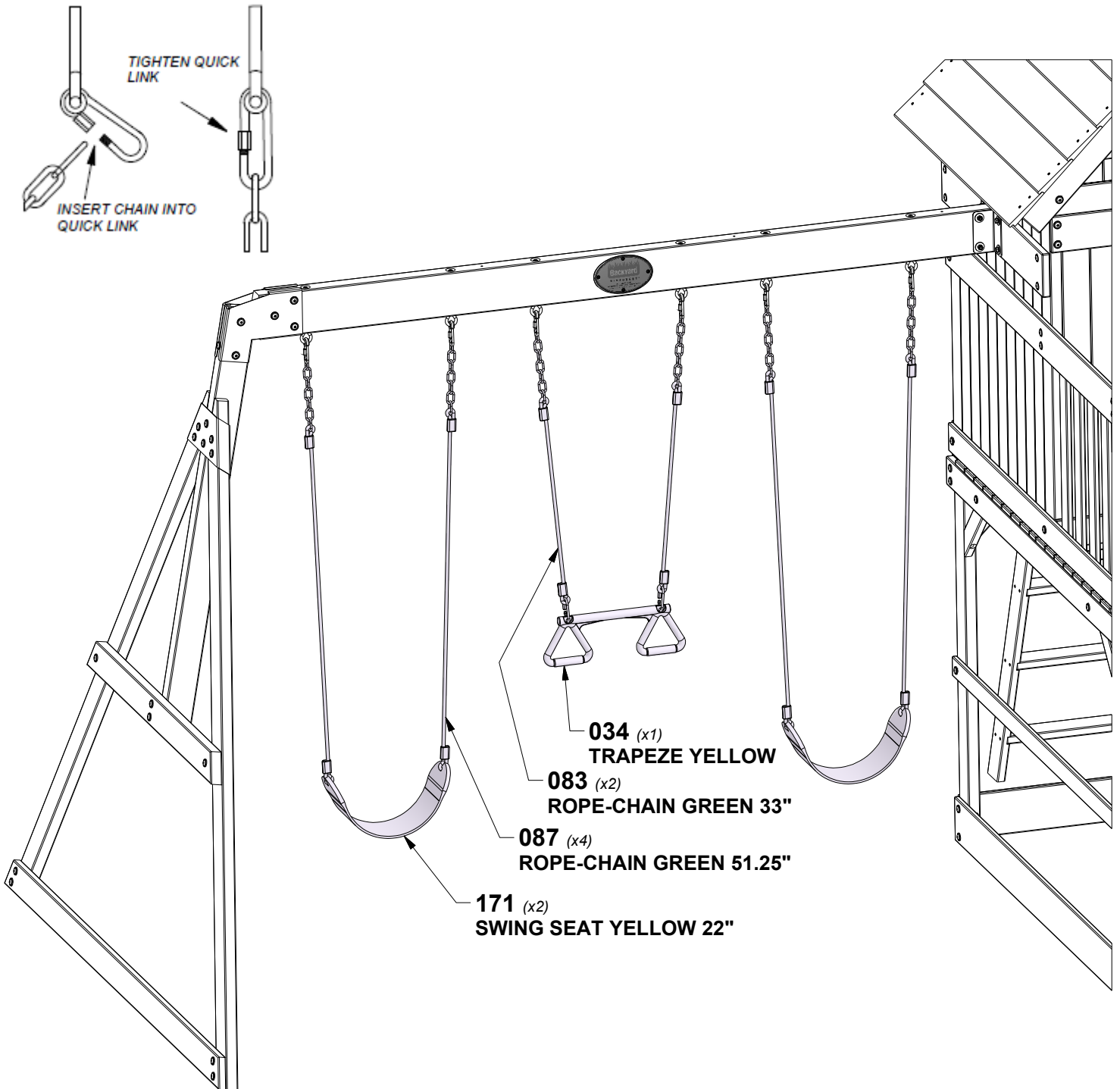
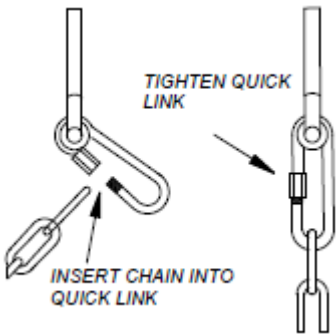

STEP 5 - FINAL ASSEMBLY

QTY	PART NUMBER	DESCRIPTION
1	H100008	BOLT WH 5/16x1
2	H100009	BOLT WH 5/16x1 1/4
1	H100010	BOLT WH 5/16x1 1/2
8	H100074	T-NUT 5/16

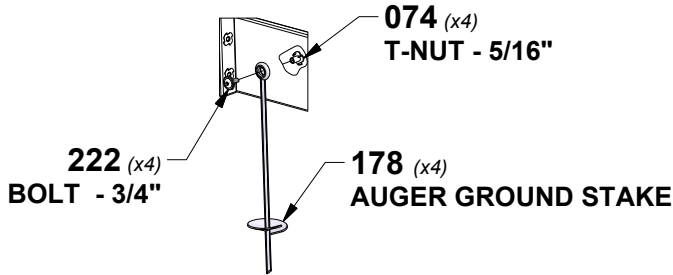

DETAIL 'B'

TWIST GROUND STAKE INTO GROUND AT LOCATIONS SHOWN. USING AUGER STAKE AS A GUIDE, DRILL A 7/16" [10mm] HOLE FOR HARDWARE.

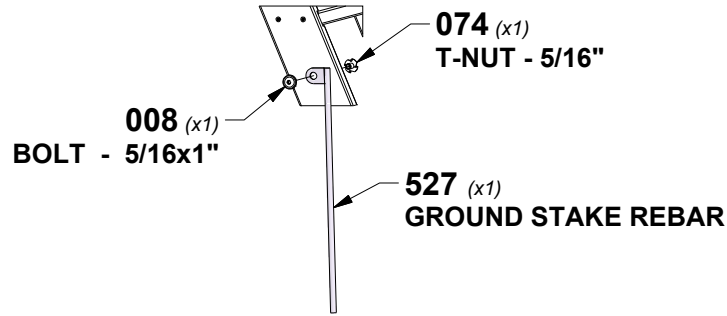

DETAIL 'C'

TWIST GROUND STAKE INTO GROUND AT LOCATIONS SHOWN. USING REBAR STAKE AS A GUIDE, DRILL A 7/16" [10mm] HOLE FOR HARDWARE.

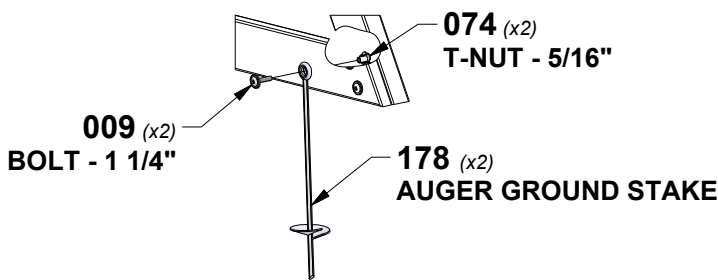
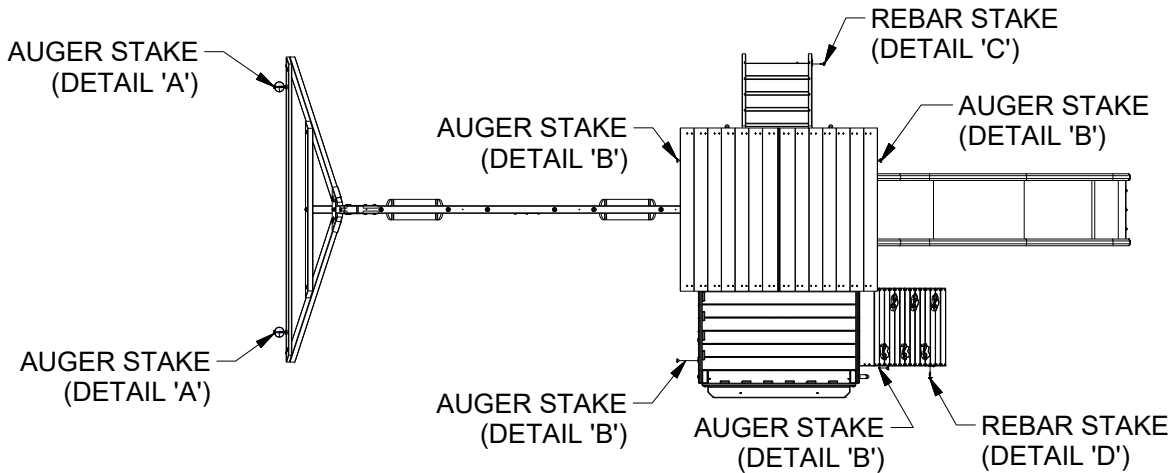

DETAIL 'A'

TWIST GROUND STAKE INTO GROUND AT LOCATIONS SHOWN. USING AUGER STAKE AS A GUIDE, DRILL A 7/16" [10mm] HOLE FOR HARDWARE.

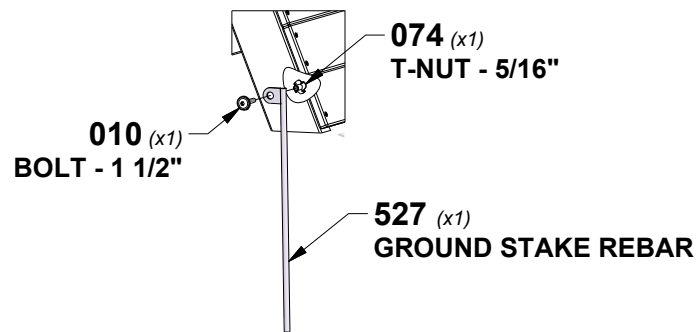

DETAIL 'D'

TWIST GROUND STAKE INTO GROUND AT LOCATIONS SHOWN. USING REBAR STAKE AS A GUIDE, DRILL A 7/16" [10mm] HOLE FOR HARDWARE.