

# 80-20101-40

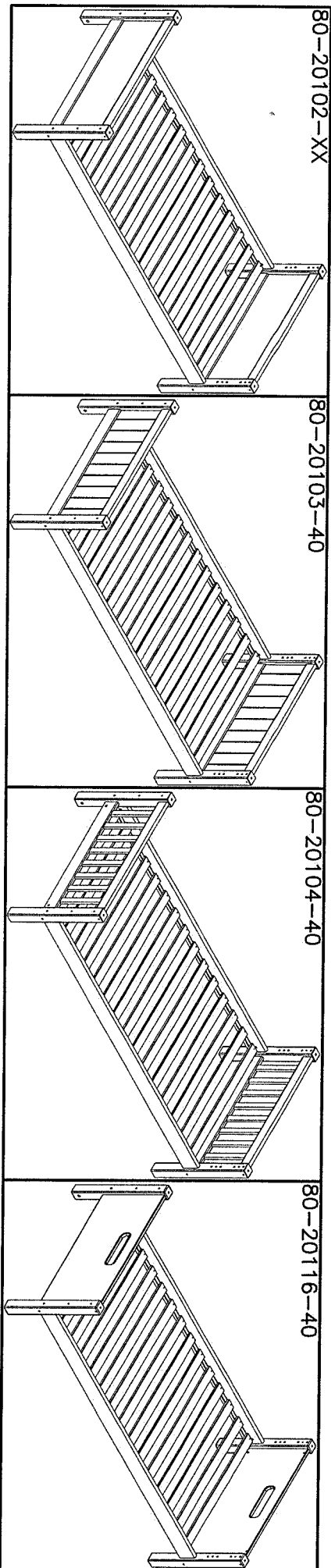

See assembly instruction in box no.  
 Voir notice de montage dans la caisse no.  
 Siehe Aufbauanleitung im Karton no.  
 Zie voor de montage-instructie pakkeotr.

Before assembling this product, please ensure that all the components supplied comply with the list on this page. All Screw-type fittings can be tightened with this tool.

Avant de commencer l'assemblage, veuillez contrôler si tous les objets indiqués sont présents. Tous les vis peuvent être serrés par cet outil.

Bevor Sie mit dem Aufbau beginnen, kontrollieren Sie ob alle auf der Zeichnung angegebenen Teile vorhanden sind. Bitte verwenden Sie zur Montage einen Kreuzschraubenzieher und den beiliegenden Innerschraubenschlüssel.

Wire-nr. Part no. Ref No. Stock Qty. Dim. Mass Dim.

12-06306473-40 2 stick/pcs 12-06306474-40 2 stick/pcs 1305-19672-40 2 stick/pcs

1967x115x26

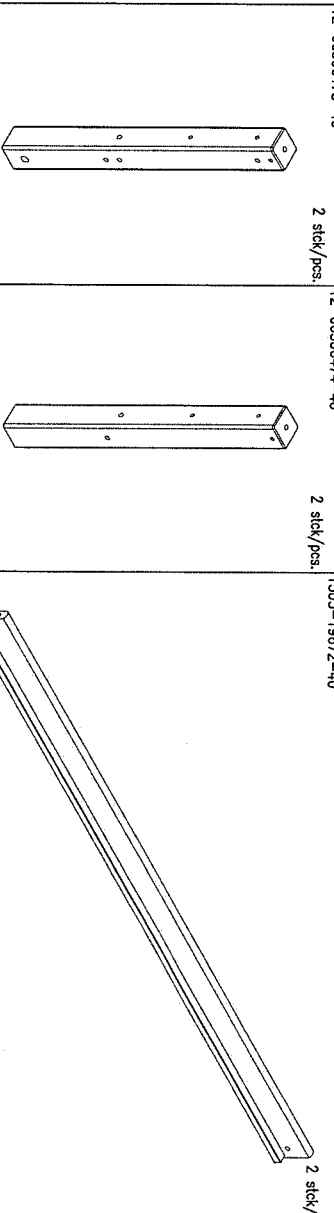

A 647x63x63 B 647x63x63 C 1967x115x26

3922-08018 8 stick/pcs 3930-10050 16 stick/pcs 3909-70100 4 stick/pcs 3901-40030 30 stick/pcs

Z1 M8/ø12x18 mm. Z2 ø10x50 mm. Z3 3938-000081-2 16 stick/pcs. Z4 ø7x100 mm. Z5 3938-00016-2 4 stick/pcs. Z6 M8x110 mm. Z7 ø8 mm. Z8 ø10 mm. Z9 4033-005 1 stick/pcs. 5 mm.

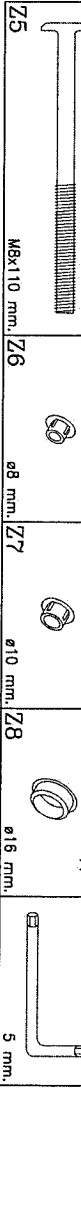

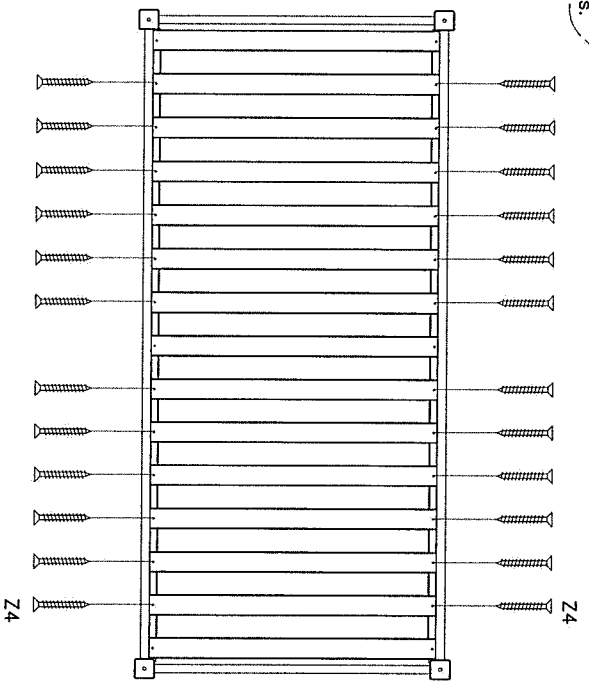
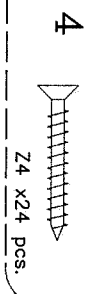
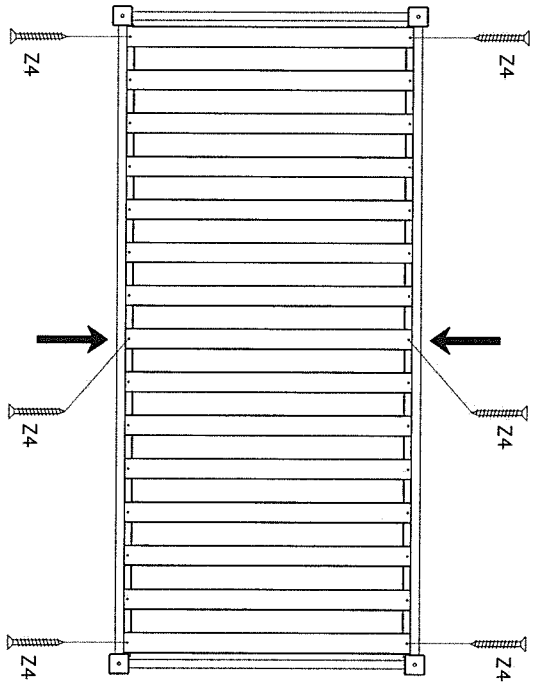
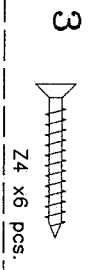
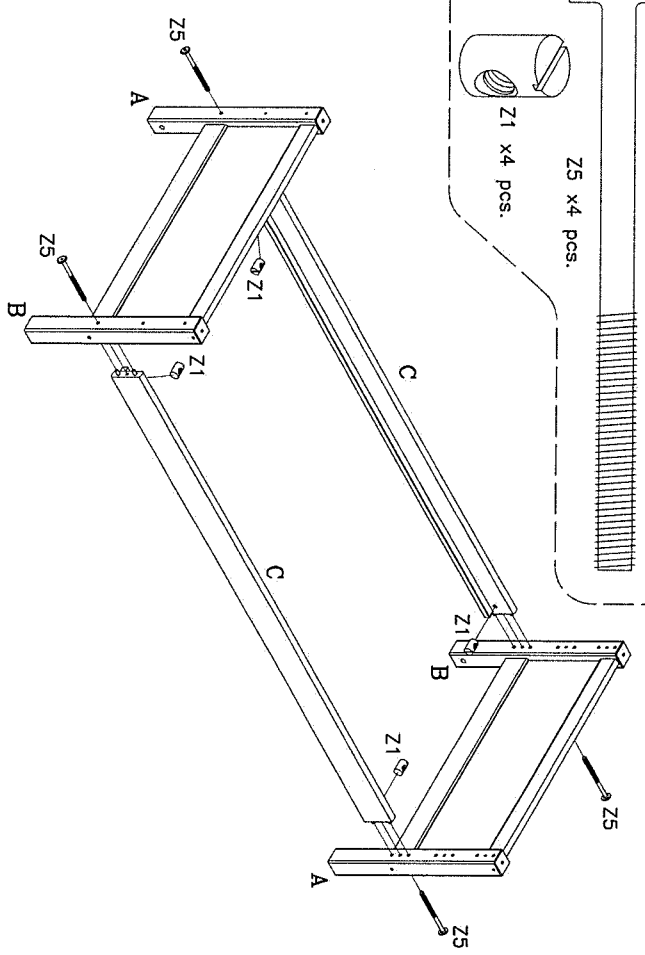
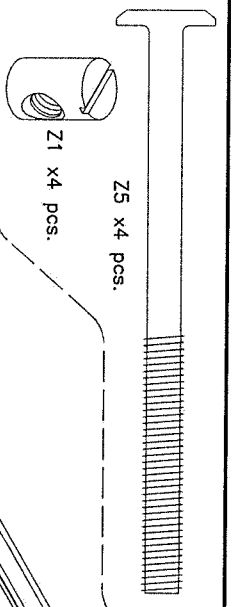
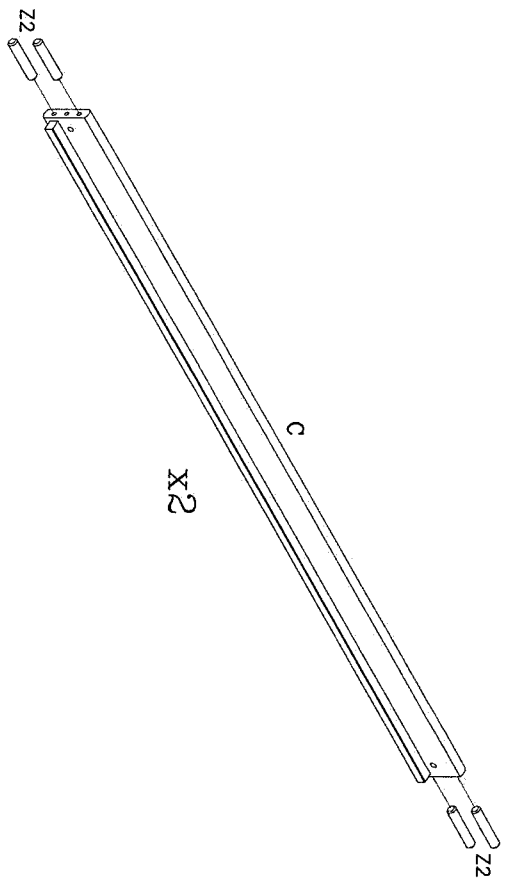
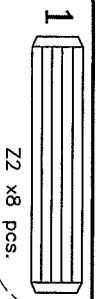

# 80-20905-40 White

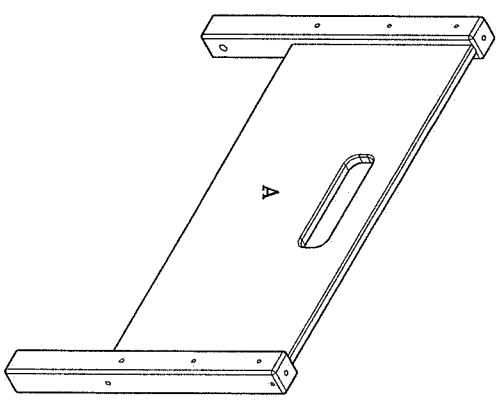

Before assembling this product, please ensure that all the components supplied comply with the list on this page. All Screw-type fittings can be tightened with this tool.

Avant de commencer l'assemblage, veuillez vérifier que tous les objets individuels sont présents. Tous les vis peuvent être serrés par cet outil.

Bevor Sie mit dem Aufbau beginnen, kontrollieren Sie ob alle auf der Zeichnung angegebenen Teile vorhanden sind. Bitte verwenden Sie zur Montage einen Kreuzschraubenzieher und den beiliegenden Innesschraubenschlüssel.

Viter-nr. Ref. No. Mess. Qty. Stk. Dim. Dim.

Siehe Bild-nr. See picture no. Image no.

4301-2208531-40	2 stick/ pcs.				
3922-060181	4 stick/ pcs.				
Z28	M6/Ø10x18mm				
3913-06110	4 stick/ pcs.	4033-004	1 stick/ pcs.		
Z29	M6x110 mm.				
					4 mm.

Z1, Z2, Z5 Fittings in single / bunk bed box.  
 Z1, Z2, Z5 Beschläge im Einzel- / Etagenbett Karton.  
 Z1, Z2, Z5 Raccords en lit simple / lit superposé.  
 Z1, Z2, Z5 Fittings in het enkelspel / stapelbed boxen.

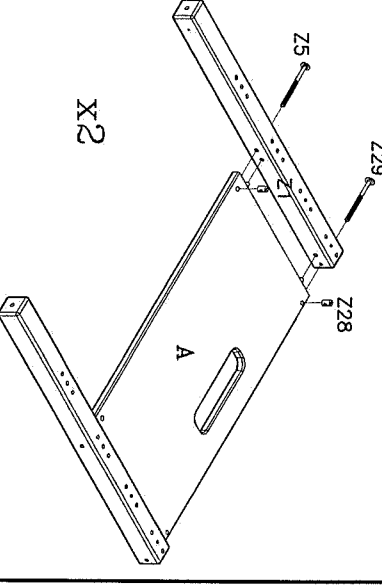
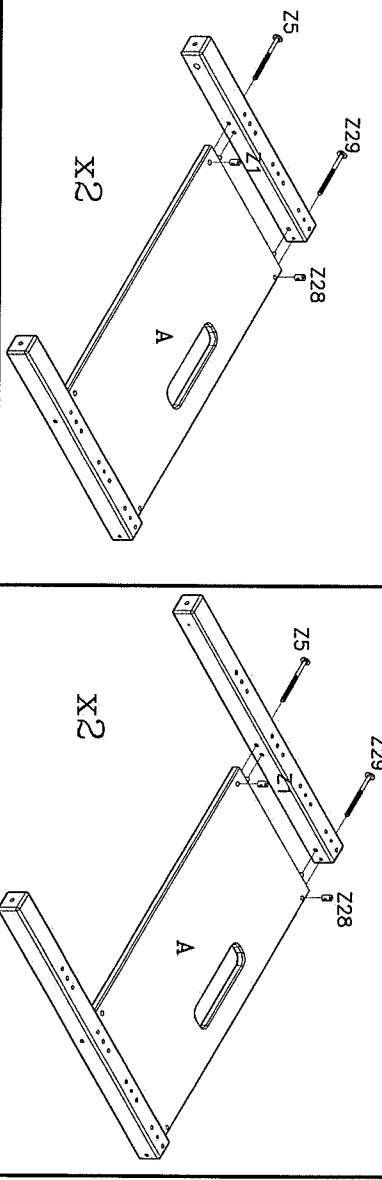
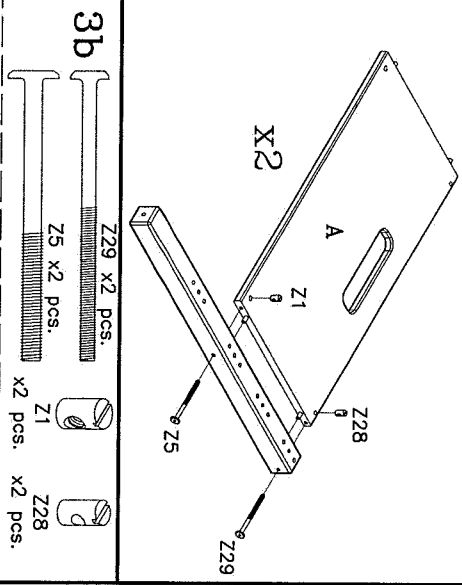
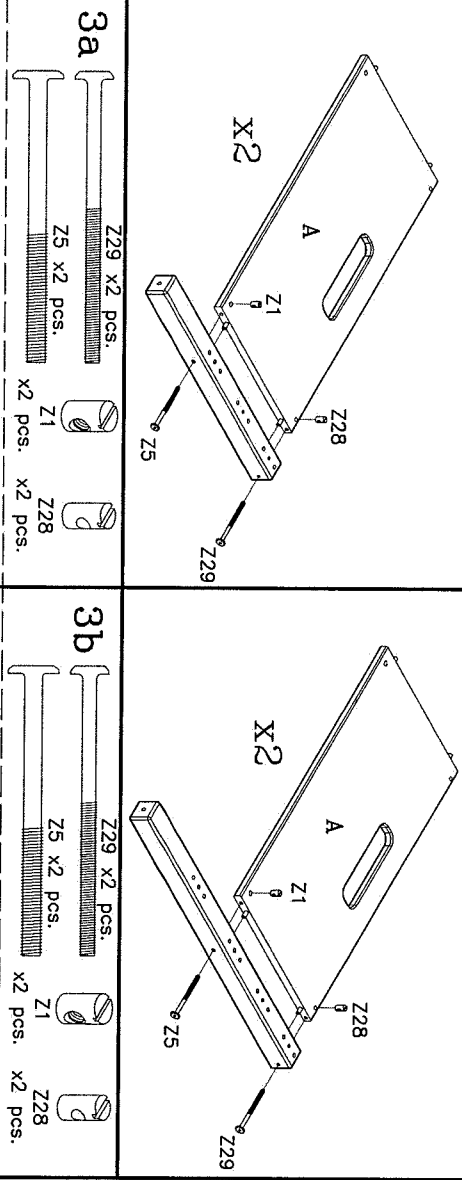
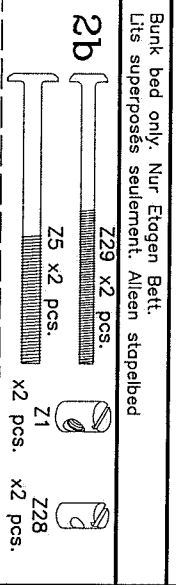
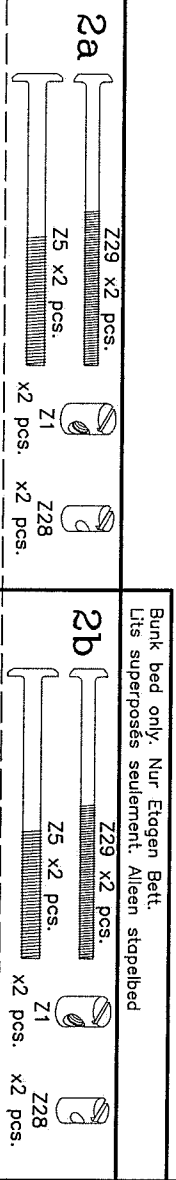
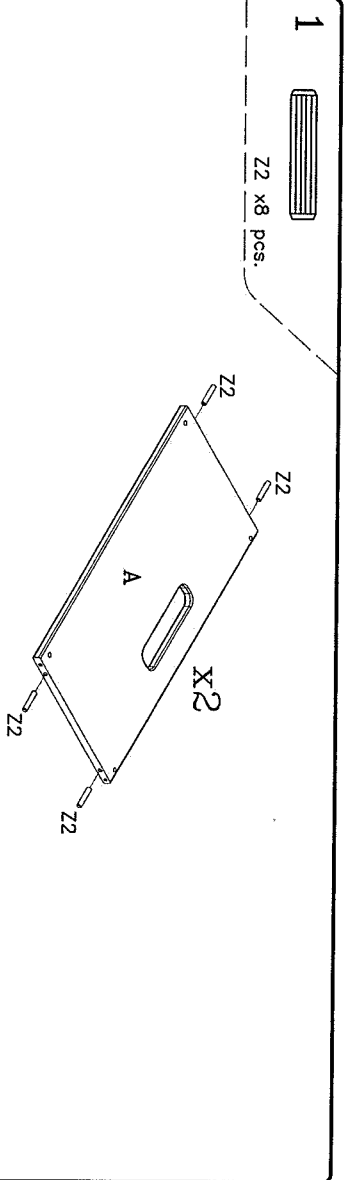

Bunk bed only. Nur Etagen Bett.  
 Lits superposés seulement. Alleen stapelbed

# 80-20601-40

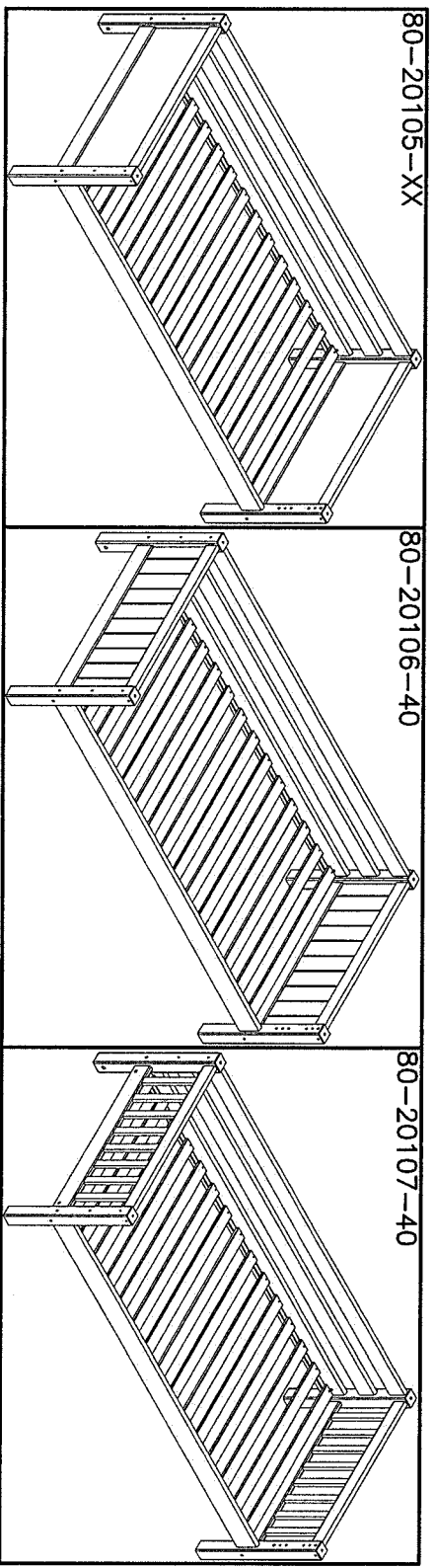

Before assembling this product, please ensure that all the components supplied comply with the list on this page. All Screw-type fittings can be tightened with this tool.

Avant de commencer l'assemblage, veuillez contrôler si tous les objets indiqués sont présents dans les vis par cet outil.

Bevor Sie mit dem Aufbau beginnen, kontrollieren Sie ob alle auf der Zeichnung angegebenen Teile vorhanden sind. Bitte verwenden Sie zur Montage einen Kreuzschraubenzieher und den beiliegenden Innensechskantschlüssel.



Ware-nr.  
Part no.  
Réf. No.

Stück.  
Qty.  
Qte.

Steh. Bild-nr.  
See picture no.  
Image no.

Mass.  
Dim.  
Dim.

12-02619676-40 2 Stück/pcs.

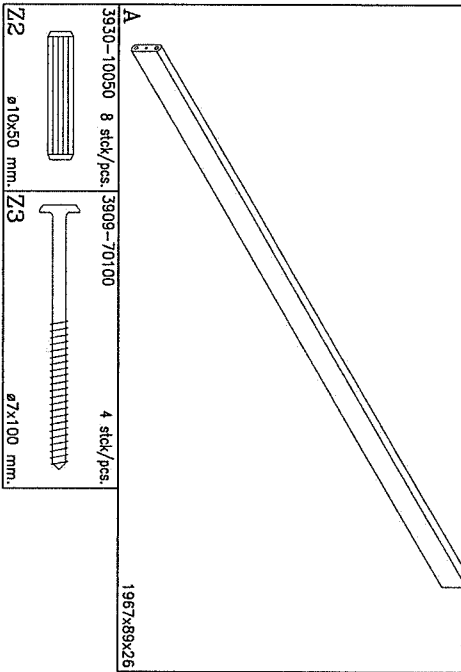

See assembly instruction in box no. 80-20101-40  
 Voir notice de montage dans la caisse no. 80-20101-40  
 Siehe Aufbauanleitung im Karton no. 80-20101-40  
 Zie voor de montage-instructie pakketnr. 80-20101-40

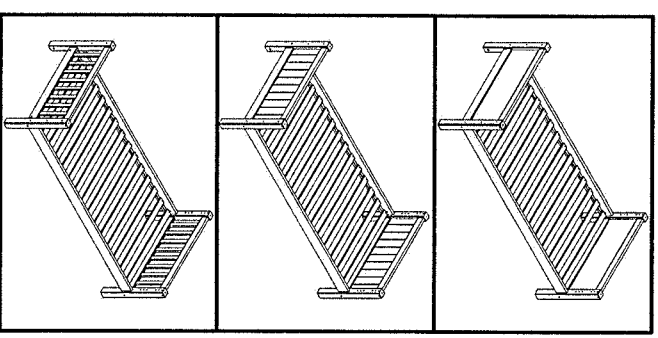



Z2, x8 pcs.

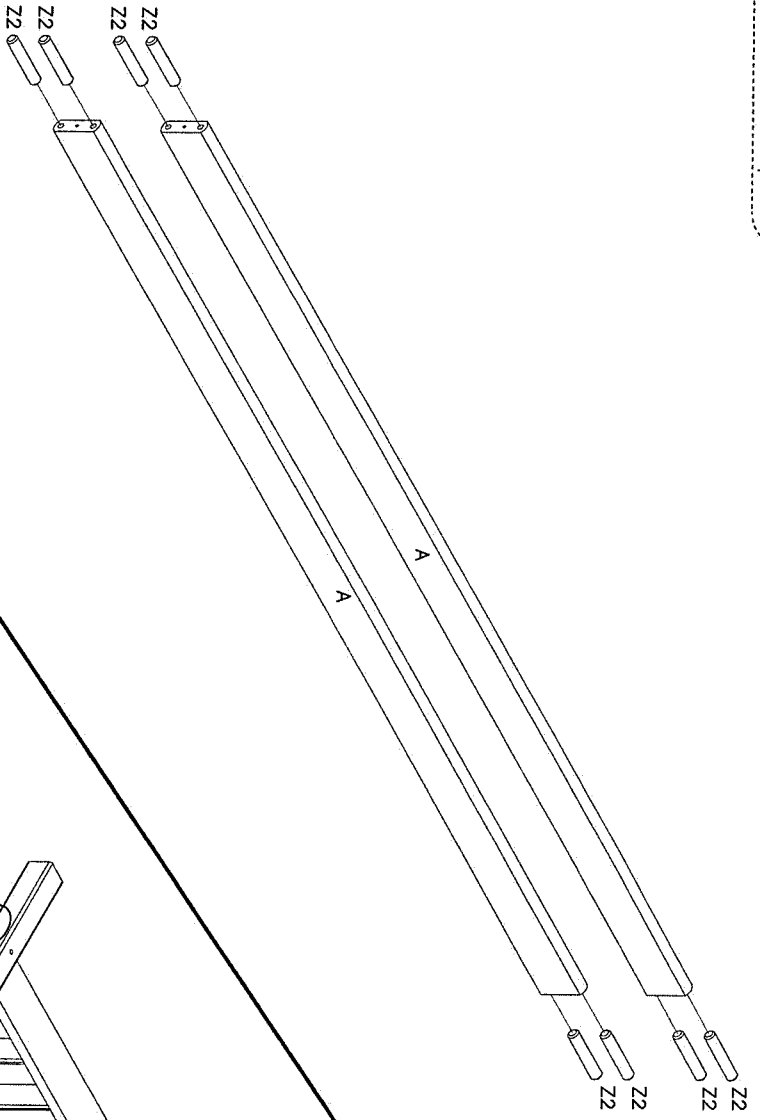

2



Z3, x4 pcs.

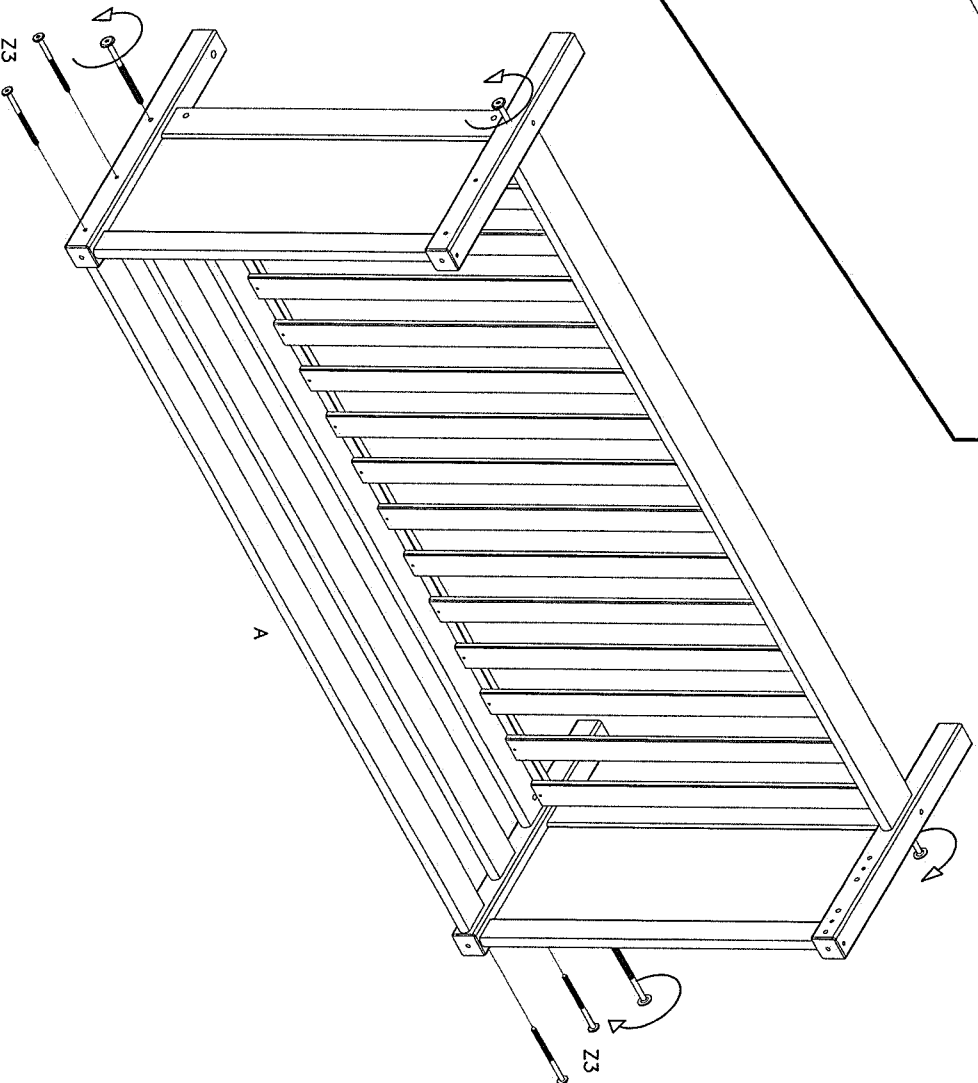

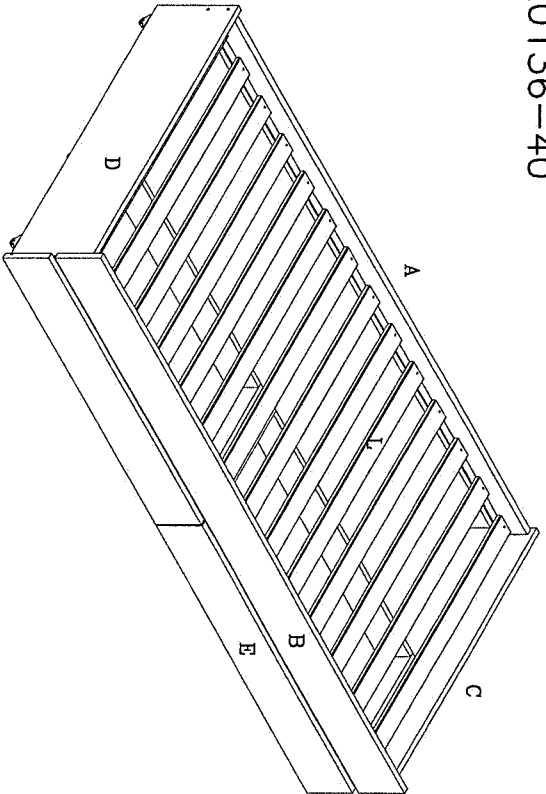

Before assembling this product, please ensure all the components supplied comply with the list on this page. All screw-type fittings can be tightened with this tool.

Avant de commencer l'assemblage, veuillez contrôler si tous les objets indiqués sont présents. Tous les vis peuvent être serrés par ces outils.

Bevor Sie mit dem Aufbau beginnen, kontrollieren Sie ob alle auf der Zeichnung angegebenen Teile vorhanden sind. Bitte verwenden Sie züher und den beiliegenden Innenschraubenschlüssel.

Ware-nr., Part no., Réf. No.

Stehe Bild-nr., See picture no., Inlage no.

Stück, Qty., Qlté.

Mass, Dim., Dim.

Part No.	Qty./Pcs.	Dimensions	Part No.	Qty./Pcs.	Dimensions	Part No.	Qty./Pcs.	Dimensions	Part No.	Qty./Pcs.	Dimensions	Part No.	Qty./Pcs.	Dimensions	
1331-19005	1	stick/pcs	1331-19554-40	1	stick/pcs	13-01809251-40	1	stick/pcs	15-01809252-40	1	stick/pcs	15-01809751-40	2	stick/pcs	
<p><b>A</b> 1900x89x20 <b>B</b> 1955x145x18 <b>C</b> 925x260x18 <b>D</b> 925x260x18</p>															
3908-70050	4	stick/pcs	3902-35012	24	stick/pcs	3901-40030	28	stick/pcs	3901-40050	4	stick/pcs	3933-15010	12	stick/pcs	
Z1	8	stick/pcs	Z2	35x12 mm	Z3	4x30 mm	Z4	4x60 mm	Z9	6	stick/pcs	3933-15028	4	stick/pcs	
3901-35040	8	stick/pcs	3917-10012	4	stick/pcs	3922-10028	4	stick/pcs	3930-08030	6	stick/pcs	3933-15028	4	stick/pcs	
Z5	35x40 mm	Z6	M10x12 mm	Z7	M10/615x28 mm	Z8	48x30 mm	Z10	4	stick/pcs	3940-000201	2	stick/pcs		
4033-004	1	stick/pcs	4003-042	12	stick/pcs	3934-10115	4	stick/pcs	3938-00016-2	4	stick/pcs	3940-000201	2	stick/pcs	
Z11	64 mm	Z12		Z13	M10/610x15 mm	Z14	16x5,8 mm	Z15	18/64,5x20 mm	Z16	2	stick/pcs	Z17	12	stick/pcs
<p><b>E</b> 4309-0308921 2 stick/pcs 975x145x18 <b>F</b> 12-02600701-40 1 stick/pcs 881x115x15 <b>G</b> 12-01504501 2 stick/pcs 450x115x15 <b>H</b> 12-01504502 2 stick/pcs 450x115x15</p>															
<p><b>I</b> 892x446/223x3 <b>J</b> 70x65x26 <b>K</b> 140x63x63 <b>L</b> 897x65x14,7</p>															

(GB): MAINTENANCE INSTRUCTIONS:  
Screws and bolts should from time to time be retightened.  
CLEANING: Wood, lacquered and oiled as well as laminated surfaces should be wiped over with a cloth and a mild soap.  
OIL: Oiled surfaces can be cleaned with soapy water, e.g. brown soap. Wipe with a clean cloth.  
To maintain the natural life in the furniture which is provided by the oil treatment, we recommend an oil treatment of the furniture 1-2 times per year. The sources manual oil for maintenance of oil-treated furniture is available at your local furniture store.

(D): PLEGEANWEISUNG:  
Schrauben und Bolzen sollten regelmäßig nachgezogen werden.  
REINIGUNG: Holz, lackierte Holzoberflächen können mit einem sauberen Lappen und milden Seifenwasser gereinigt werden. Um das natürliche Aussehen des Holzes zu bewahren, ist eine Öl-Nachbehandlung vom Möbelstück 1 bis 2 Mal pro Jahr empfehlenswert. Das farblose Öl für die Nachbehandlung der Möbel kann in Ihrem Möbelschicht gekauft werden.

(F): CONSEILS D'ENTRETIEN:  
Votre lit doit être verifié périodiquement afin de resserrer les vis.  
NETTOYAGE: Les surfaces en bois, laquées, peintes et laminées peuvent être nettoyées avec de l'eau savonneuse et un chiffon propre. Pour maintenir l'aspect naturel du bois, nous vous recommandons de traiter avec une huile d'ameublement 1-2 fois par an. L'huile naturelle sans colorant peut être achetée dans votre magasin de meuble.

- 1**
- Z8x6 pcs.
  - Z17x12 pcs.

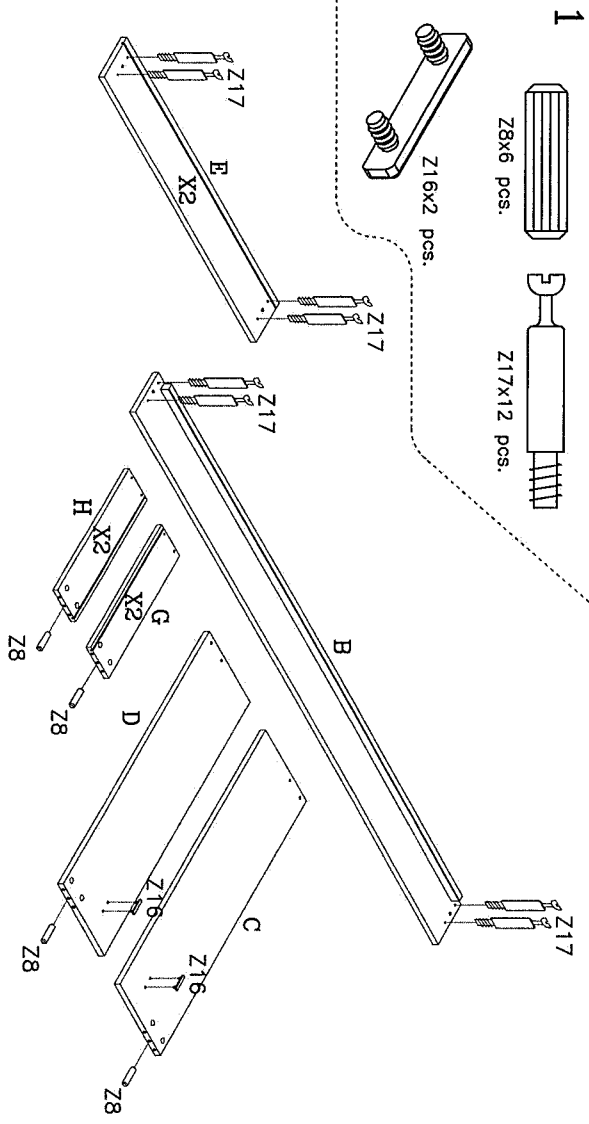

- 2**
- Z1x4 pcs.

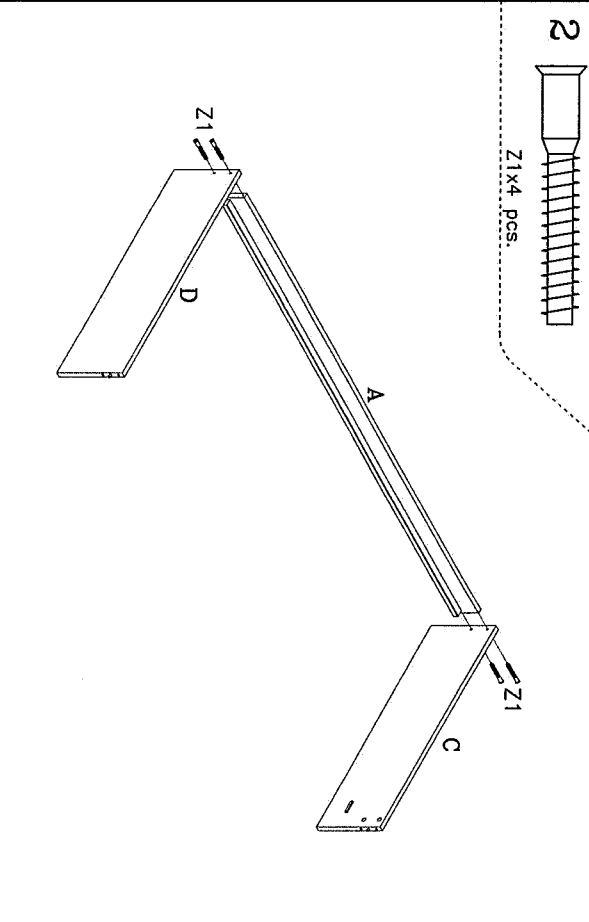

- 3**
- Z9x4 pcs.

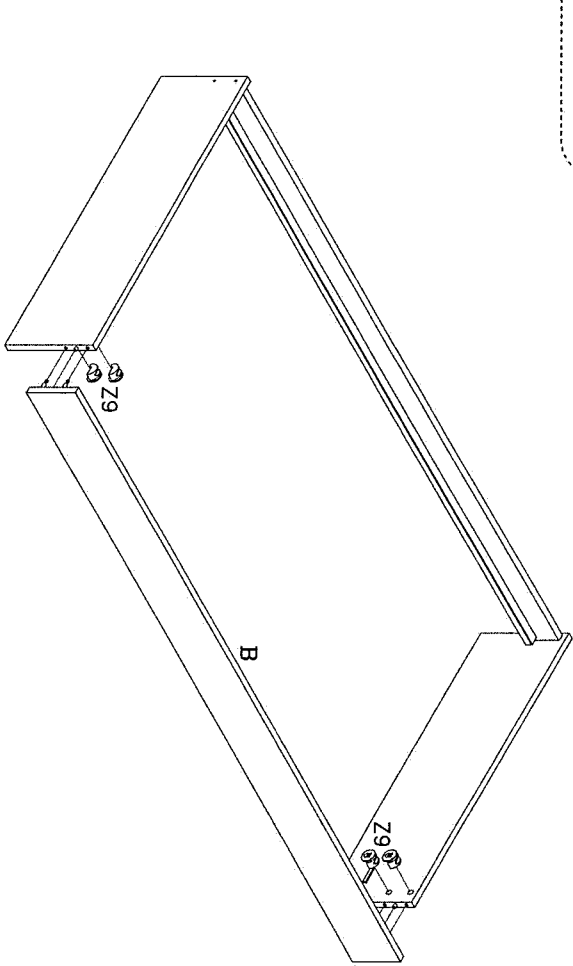

- 4**
- Z2x8 pcs.
  - Z4x2 pcs.

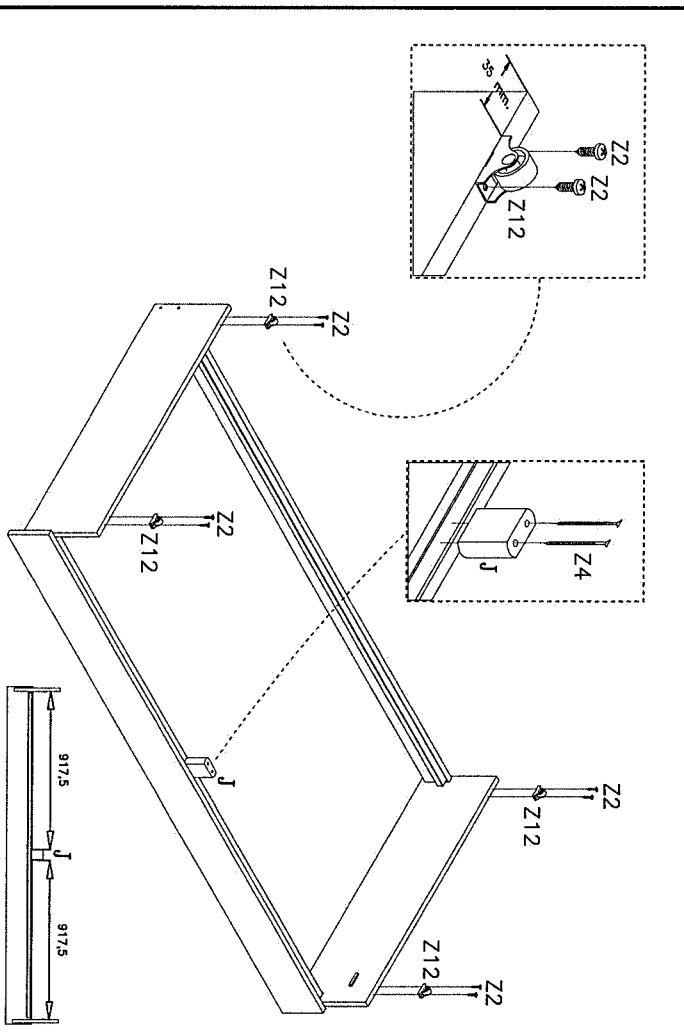

5

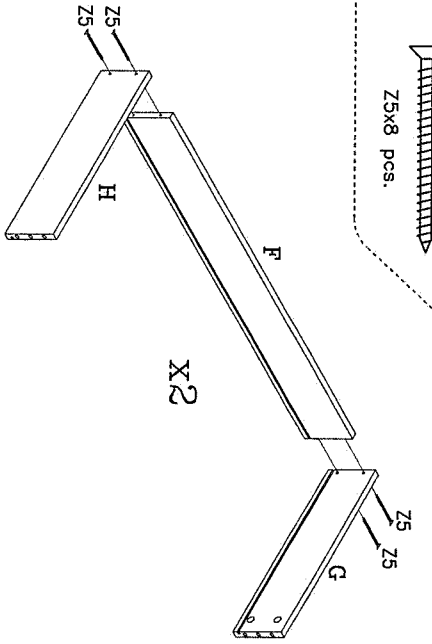
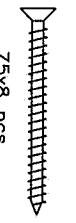

6

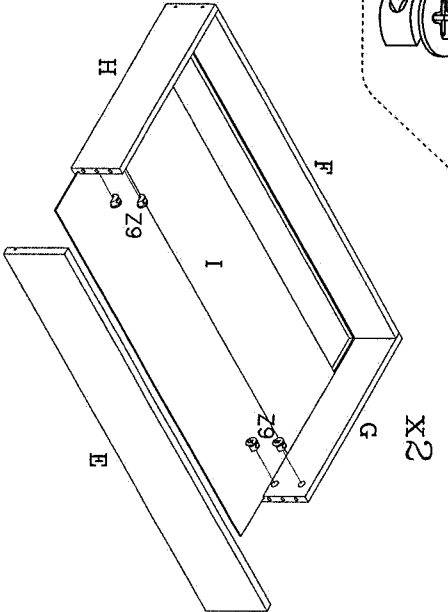

7

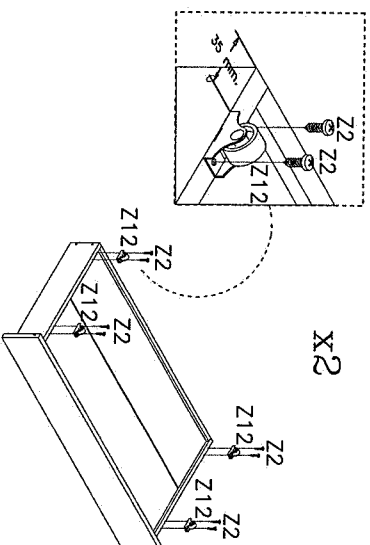
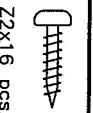

8

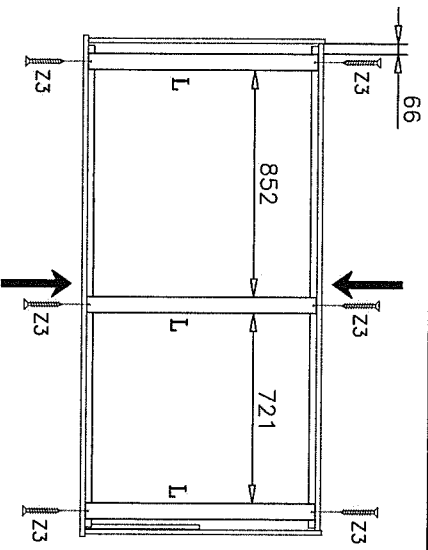
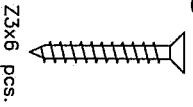

9

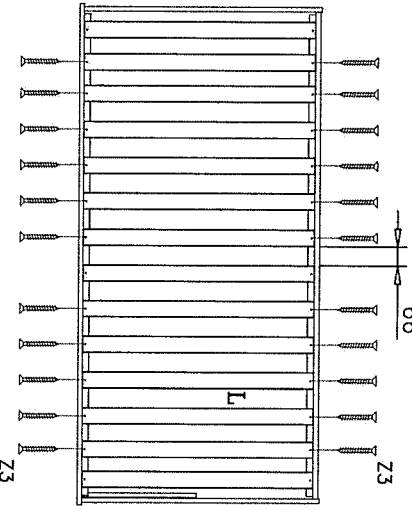
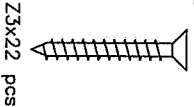

10

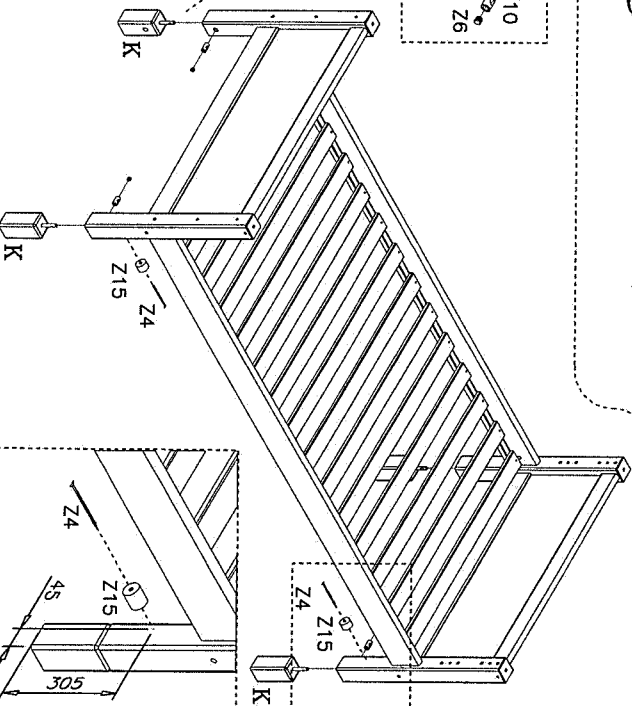
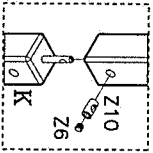
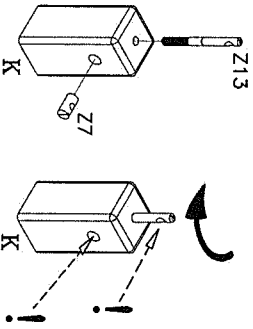
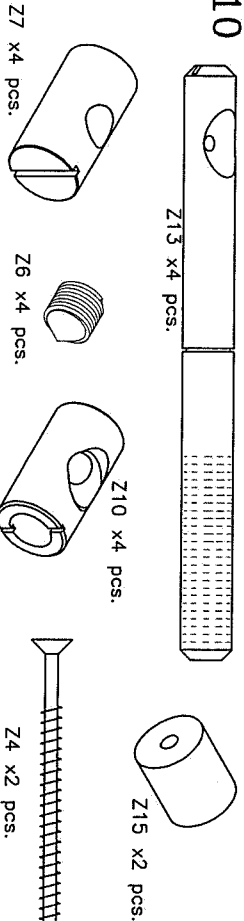

Screw the bolt Z13 into the leg, until the ring on the bolt is flush with the end of the leg.  
Schroef de bout Z13 in de poot, tot de ringranding op de poot gelijkvalt met de bovenzijde van de poot.  
Der Verbindungsboizen Z13 wird eingeschraubt, bis der markierte Ring mit der Oberkante des Pfostens bündig ist.  
Visser le goujon dans le pied, jusqu'à ce que l'anneau gravé soit à fleur avec le bois.