

Eckbankgruppe RIEDBERG

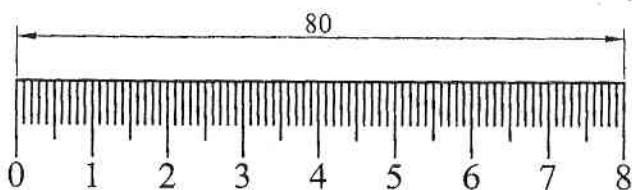

Beschlagbeutel

① Schrauben M6x35 = 12 STCK

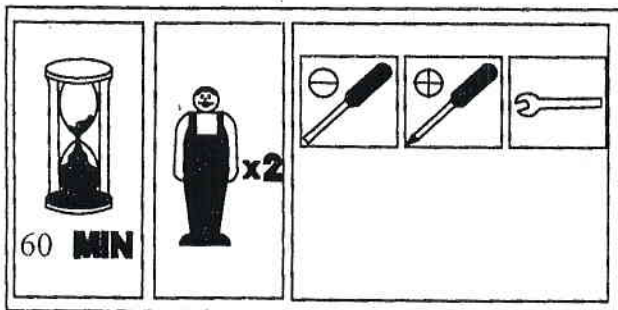
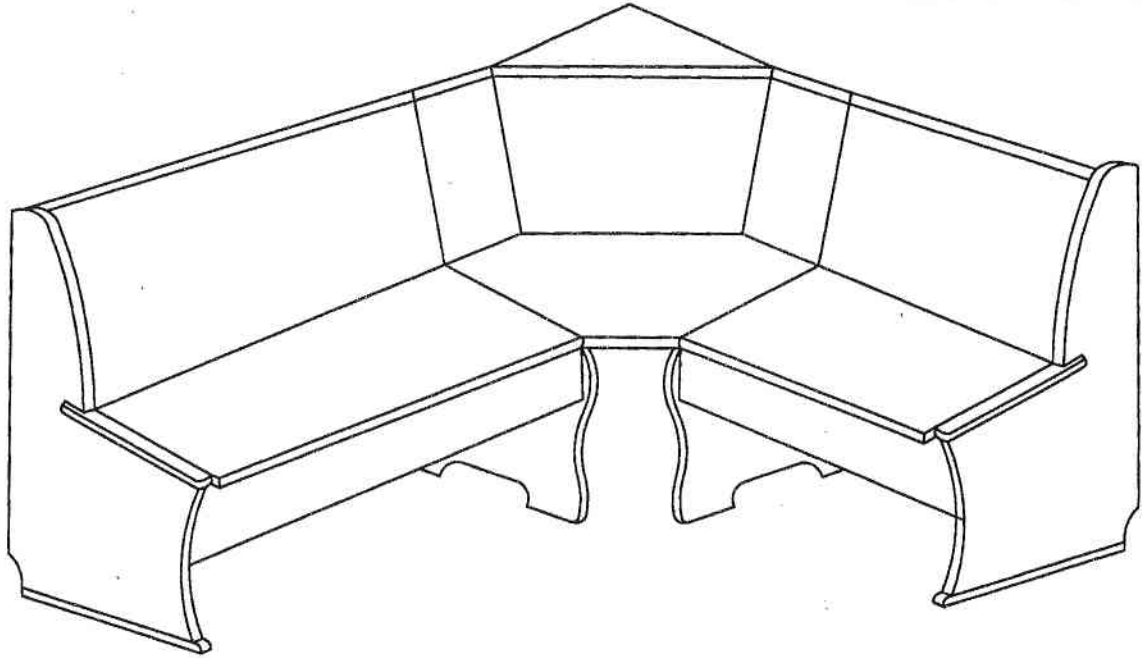

⑤ Metall - Flachwinkel = 2 STCK



② Schrauben M6x50 = 4 STCK



③ Schrauben M6x80 = 8 STCK



④ Holzschrauben 4.5 x 18 = 4 STCK



⑥ Schrauben M6x70 = 4 STCK



Scheiben = 44 STCK



Schraubenmutter = 16 STCK



⑦ Holzsurub 3.5 X 30 = 2 STCK



⑧ Holzwinkel = 1 STCK



Eckbankgruppe

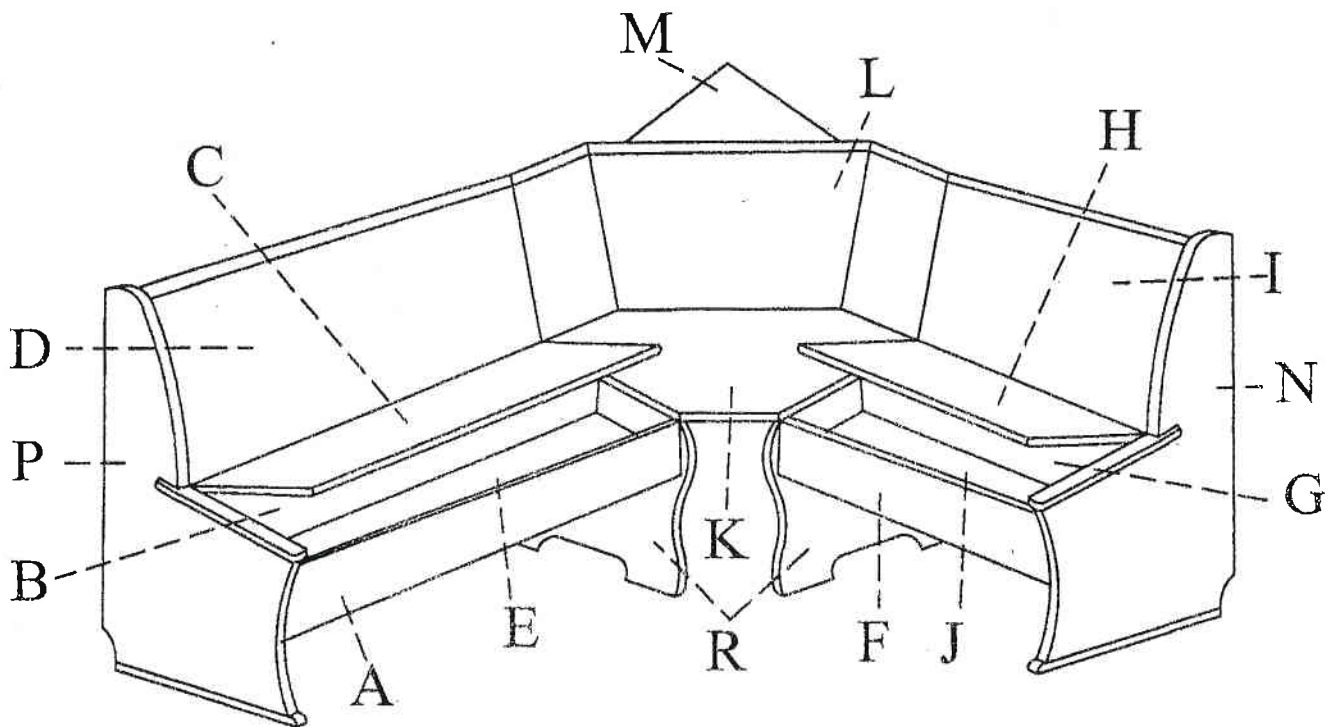

Teilebeschreibung

A-Lange Vorderblende

B-Lange Hinterblende

C-Langes Sitzteil

D-Langer Ruckenteil

E-Lange Truhenboden

F-Kurzes Vorderblende

G-Kurzes Hinterblende

H-Kurzer Sitzteil

I-Kurze Ruckenteil

J-Kurze Truhenboden

K-Ecksitzteil

L-Eckruckenteil

M-Eckablage

N-Rechte Aussenwange

P-Linke Aussenwange

R-Innenwangen

①

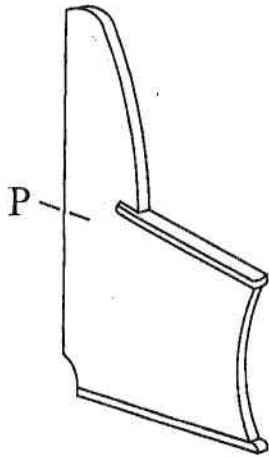

②

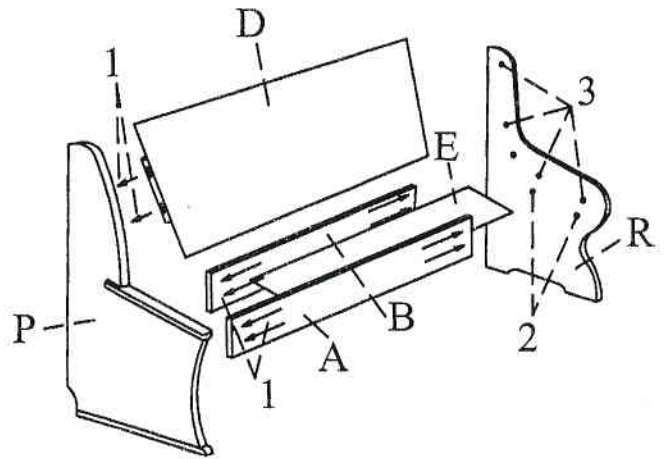

③

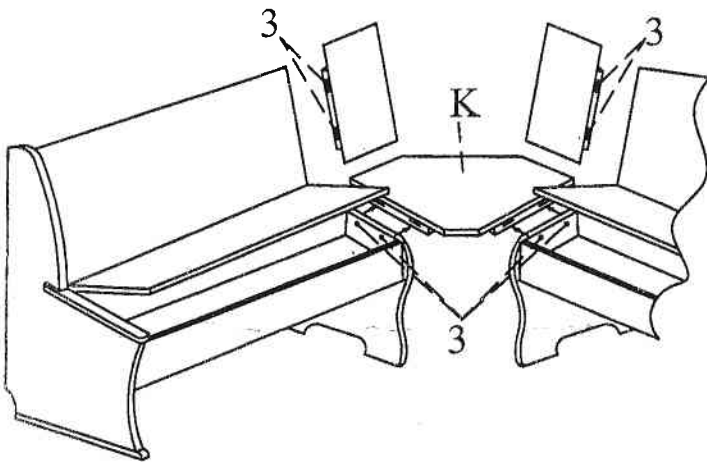

④

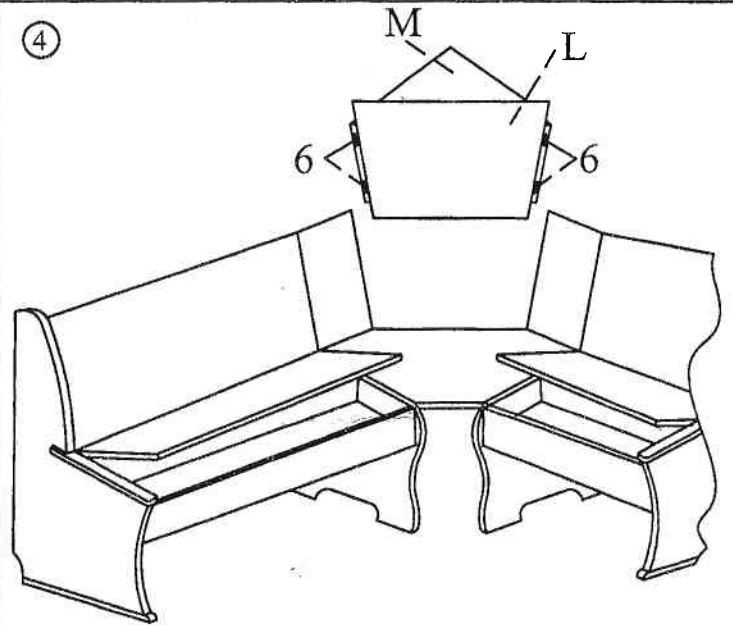

⑤

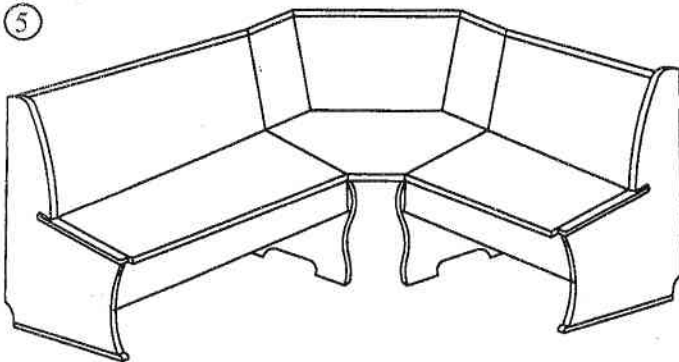

⑥

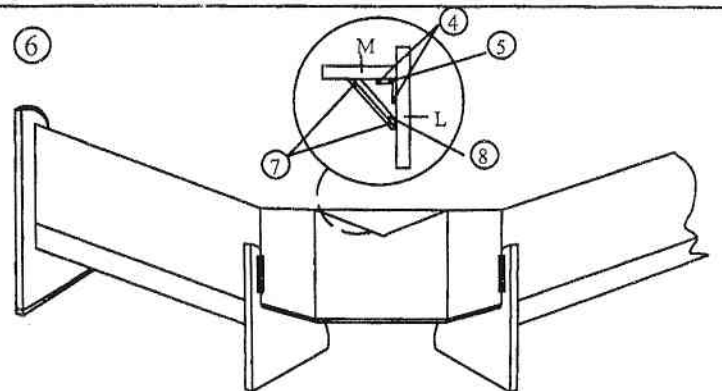

1. NACH DER MONTAGE DES LANGEN UND DES KURZEN SCHENKELS DAS ECKTEIL ZU MONTIEREN.

2. VOR DEN FESTZIEHEN DER SCHRAUBEN WERDEN DIE TEILE AUSGERICHTET (SIEHE ABBILDUNG 5).

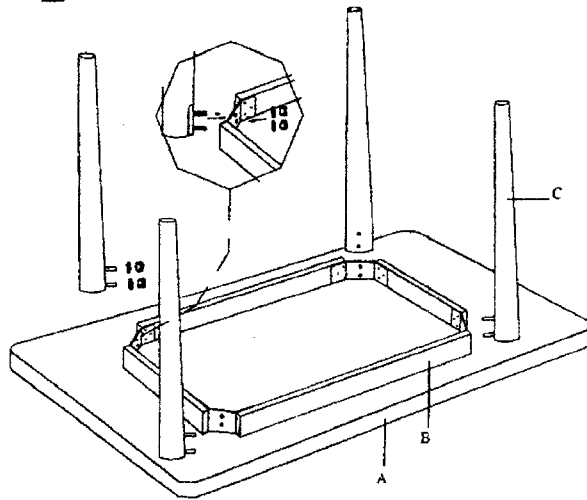

- 8 pcs
- 8 pcs

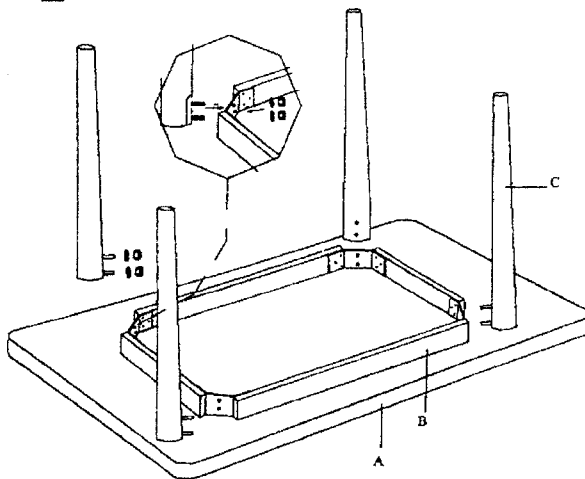

- 8 pcs
- 8 pcs