

Art. 305488 240021

LKZ 41332

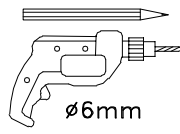

Ø6mm

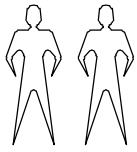
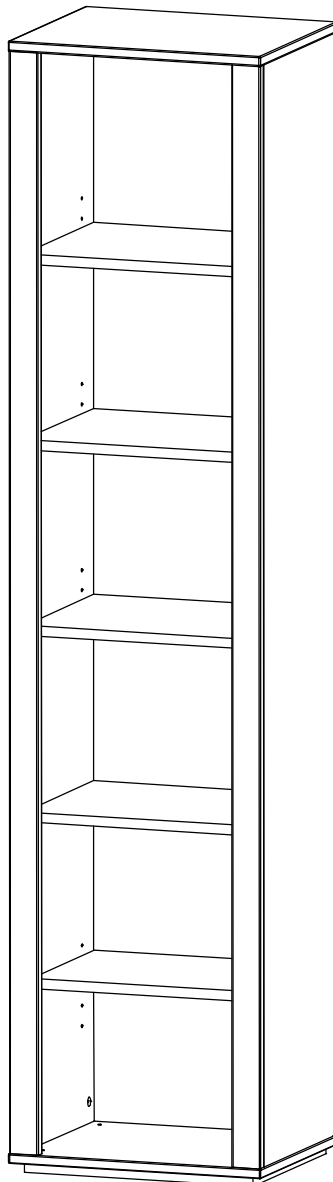
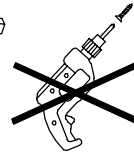

Service • Assistenza • Dienstverlening • Serwis
 Servis • Szerviz • Сервисная служба







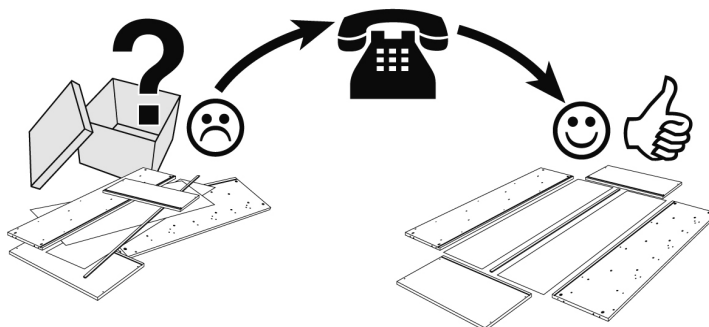
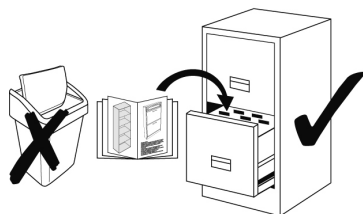

Name • Nom • Nome • Naam
 Nazwa • Jméno • Názov • Név
 Denumire • Isim • Название

Nr • No • N • Номер • Č • Sz

Typ • Type • Típus • Tipo
 Тип

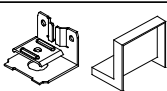

0
10
20
30
40
50
60
70
80
90
100
110
120
130
140
150
160
170
180
190
200
210

H1	 x26 ø 8x30	D5	 x24 ø 15x12,5	D2	 x24 ø 5/11x34
D4	 x24 ø 17	D31	 x1	A10	 x2 ø 4x16
D1	 x16	H8	 x1 ø 6x35	A69	 x1 ø 4x60

67296 67296/1

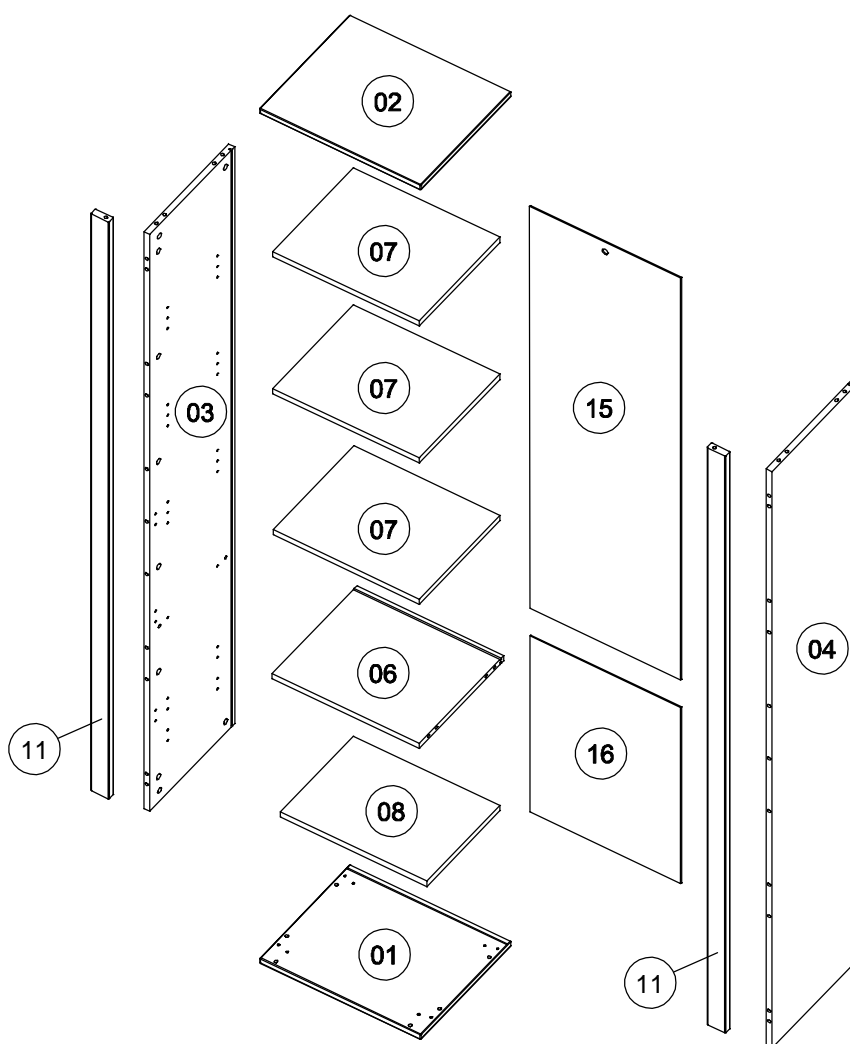

Teil Nr. Pièces Nr. Pieces Nr. Часть Ном. Kawalek Nr. Parça No Kusù Nr. Kusov Nr. Pezzi Nr. Nr piese. Darab száma. Stukken Nr. Kārtas Nr.	Anzahl Quantité Quantity Количество Ilość Miktar Množství Množstvo Quantità Cantitatea Mennyiség Hoeveelheid Skaitis	Kasten Nr. Colli Nr. Colli Nr. Коробка Ном. Polu Nr. Kutusu Nr. Kolonka Č. Počet balení Colli Nr. Nu pachete Colli száma. Colli Nr. Kastes Nr.	Maß, mm Dimensions, mm Dimensions, mm Размеры, mm Wymiary, mm Boyutlar, mm Rozměry, mm Rozmery, mm Dimensioni, mm Dimensiuni, mm Méterek, mm Afmetingen, mm Izmēri, mm	✓
01	1	1/2	422 x 348 x 32	
02	1	1/2	422 x 348 x 16	
03	1	2/2	1756 x 328 x 16	
04	1	2/2	1756 x 328 x 16	
06	1	1/2	384 x 327 x 16	
07	3	1/2	383 x 312 x 16	
08	1	1/2	383 x 282 x 16	
11	2	2/2	1756 x 48 x 18	
15	1	2/2	1222 x 395 x 3	
16	1	2/2	536 x 395 x 3	

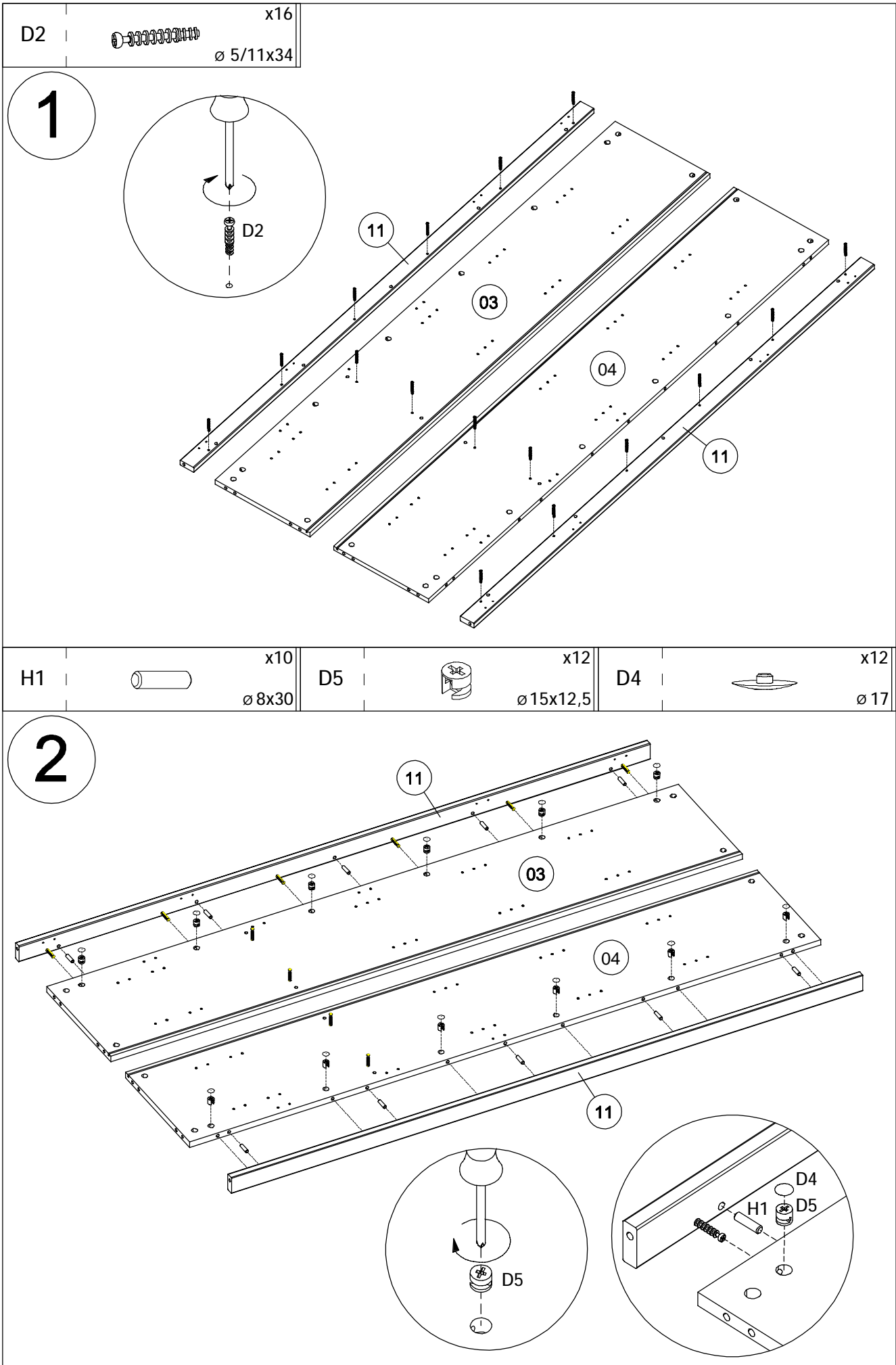

67296 67296/1





67296 67296/1

H1		x4 ø 8x30	D5		x4 ø 15x12,5	D4		x4 ø 17
----	---	--------------	----	---	-----------------	----	---	------------

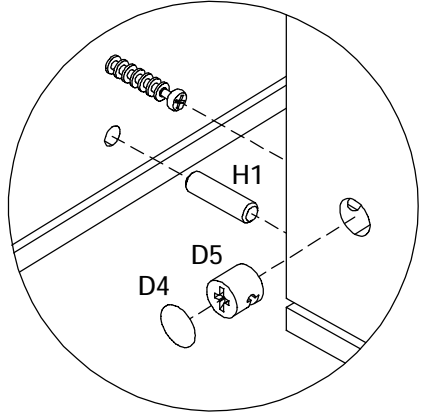
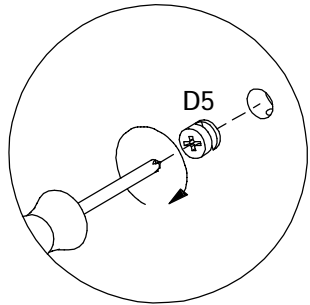
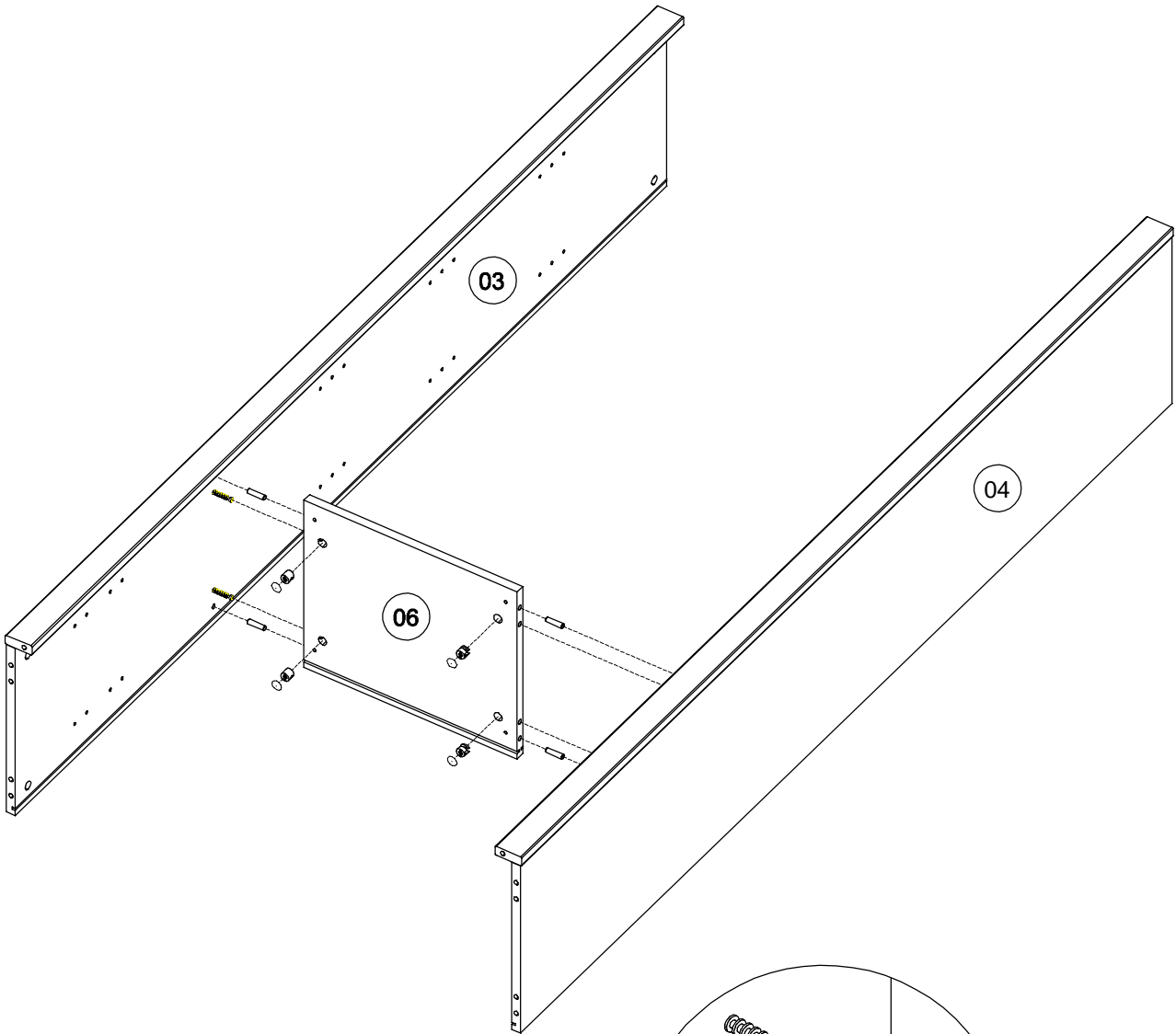

3

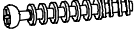
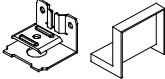

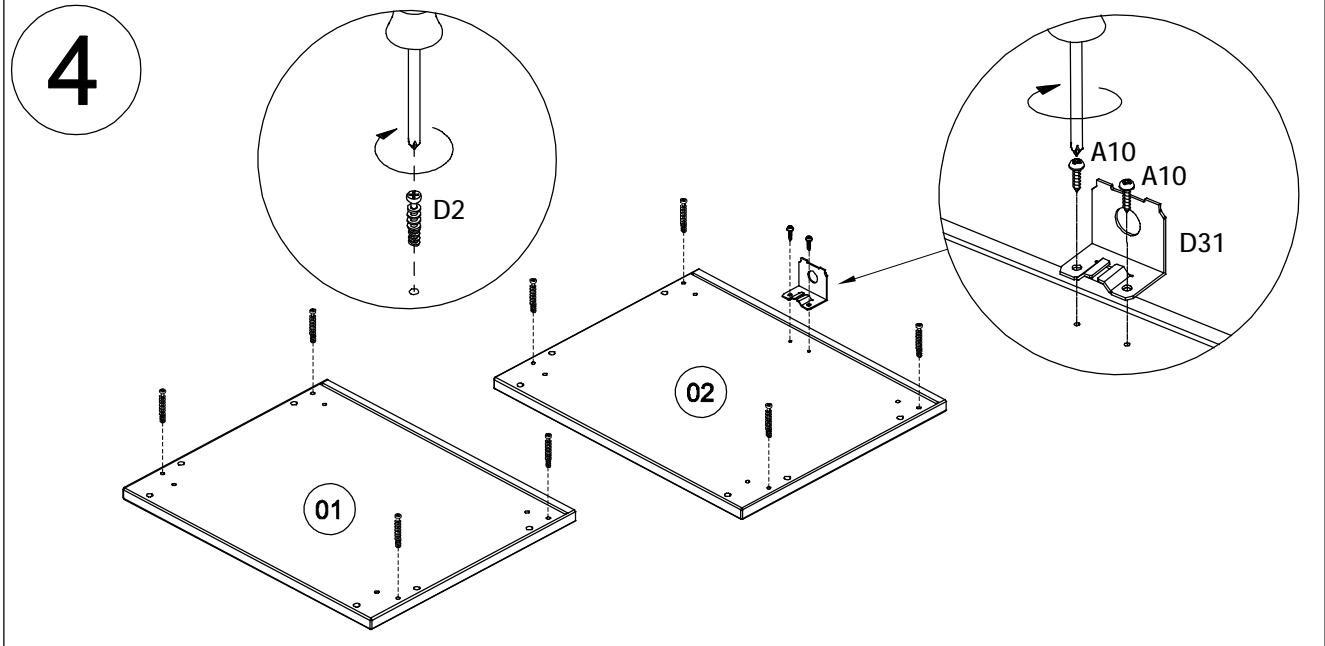

67296 67296/1

D2	 x8 ø 5/11x34	D31	 x1	A10	 x2 ø 4x16
----	---	-----	--	-----	--

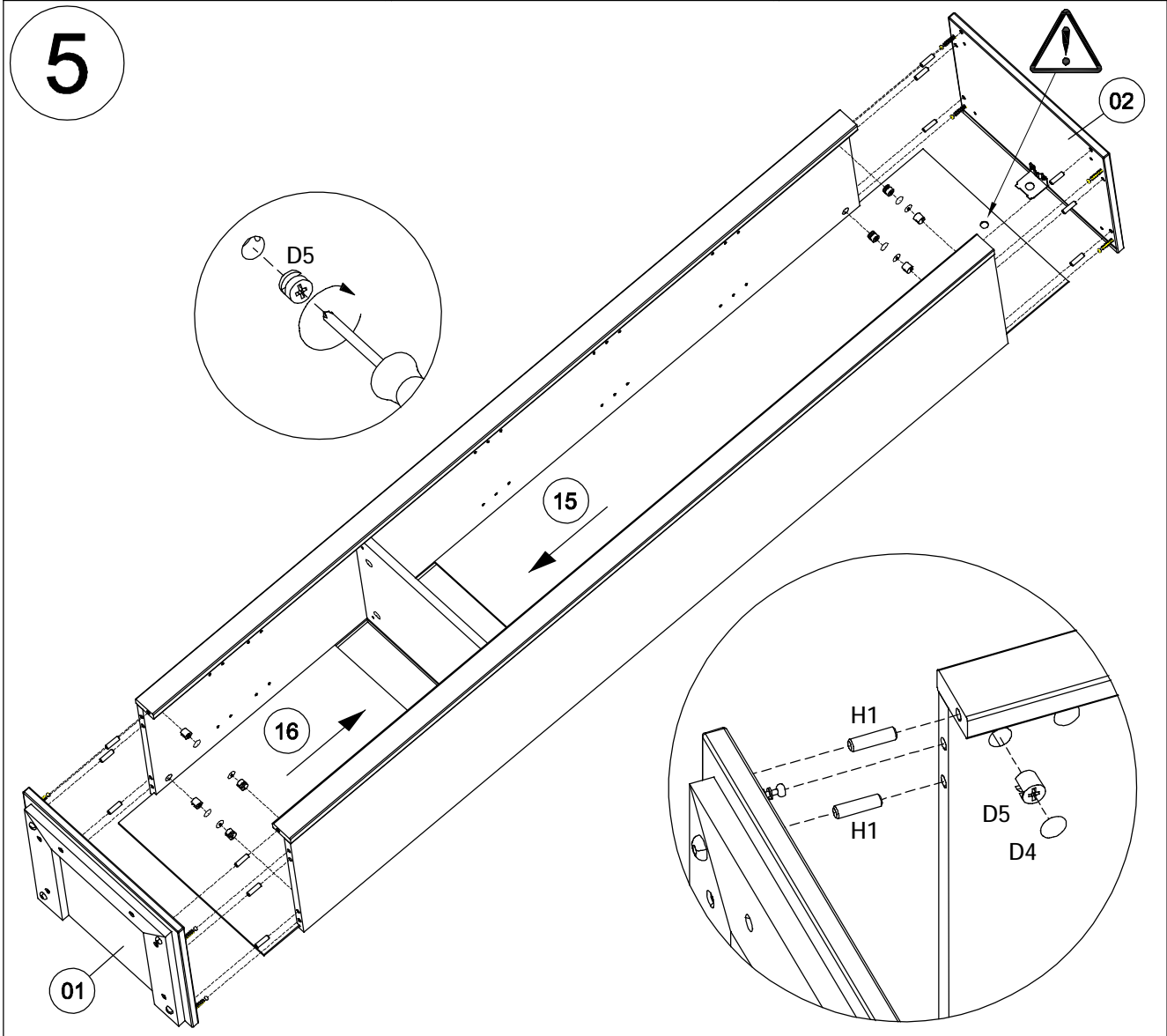

H1	 x12 ø 8x30	D5	 x8 ø 15x12,5	D4	 x8 ø 17
----	---	----	---	----	--

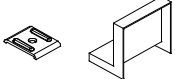

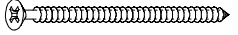
D31	 x1	H8	 x1	A69	 x1
			∅ 6x35		∅ 4x60

6

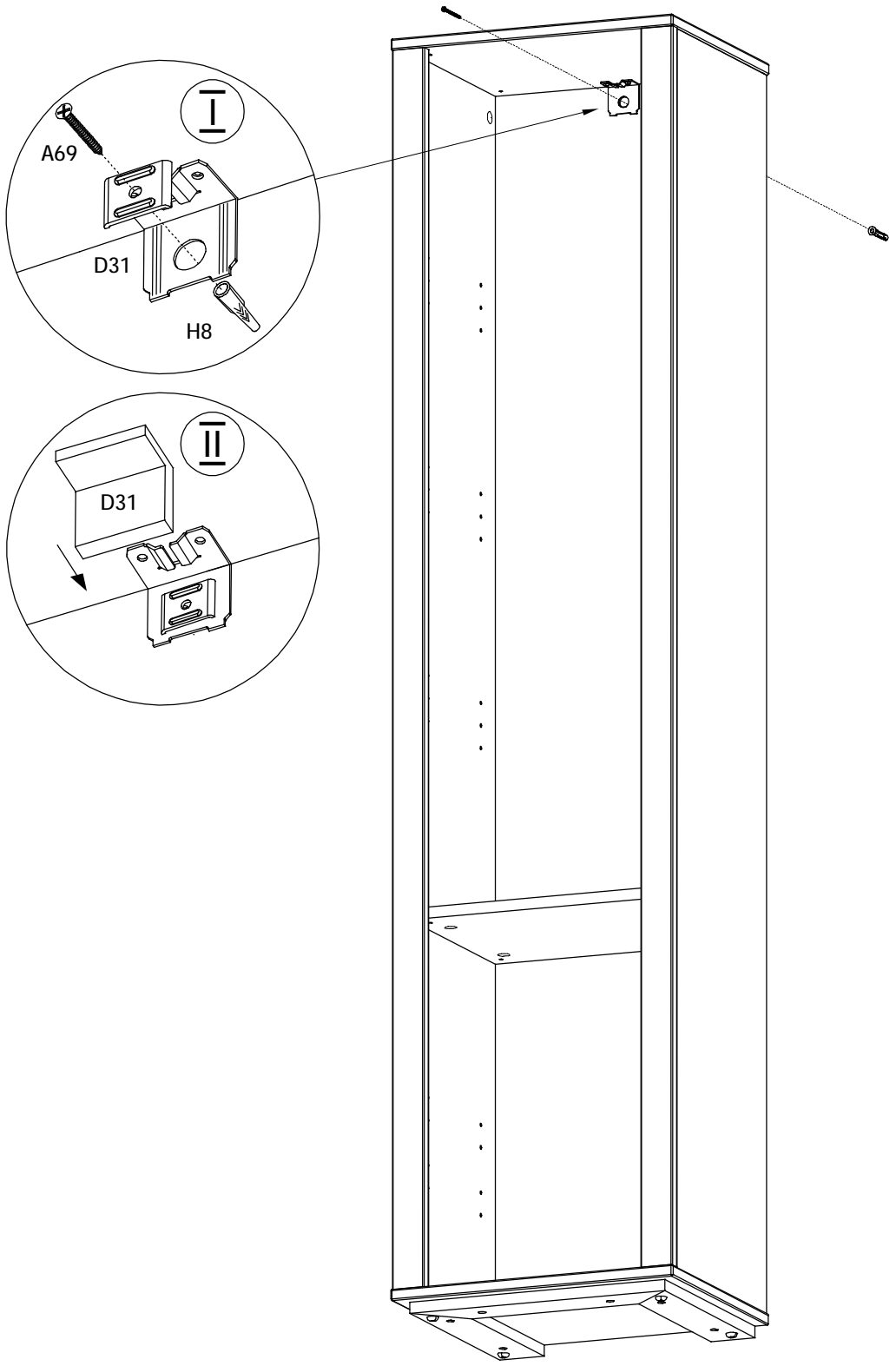
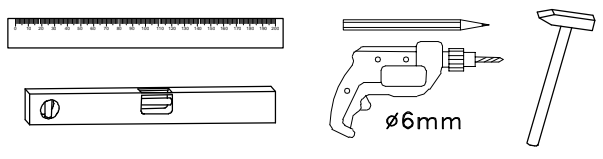

D1



x16

7

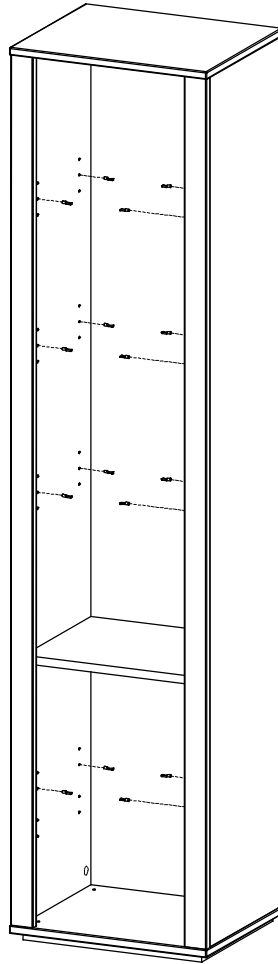
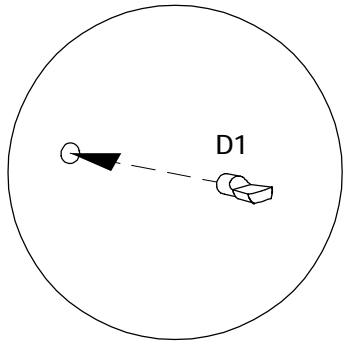

8

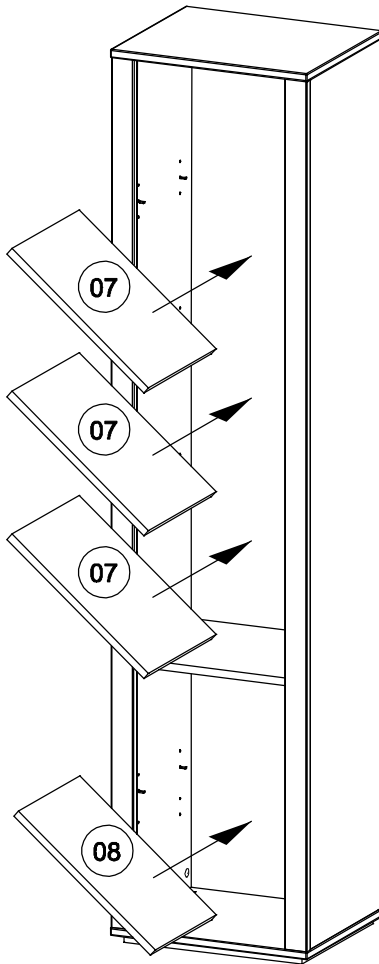

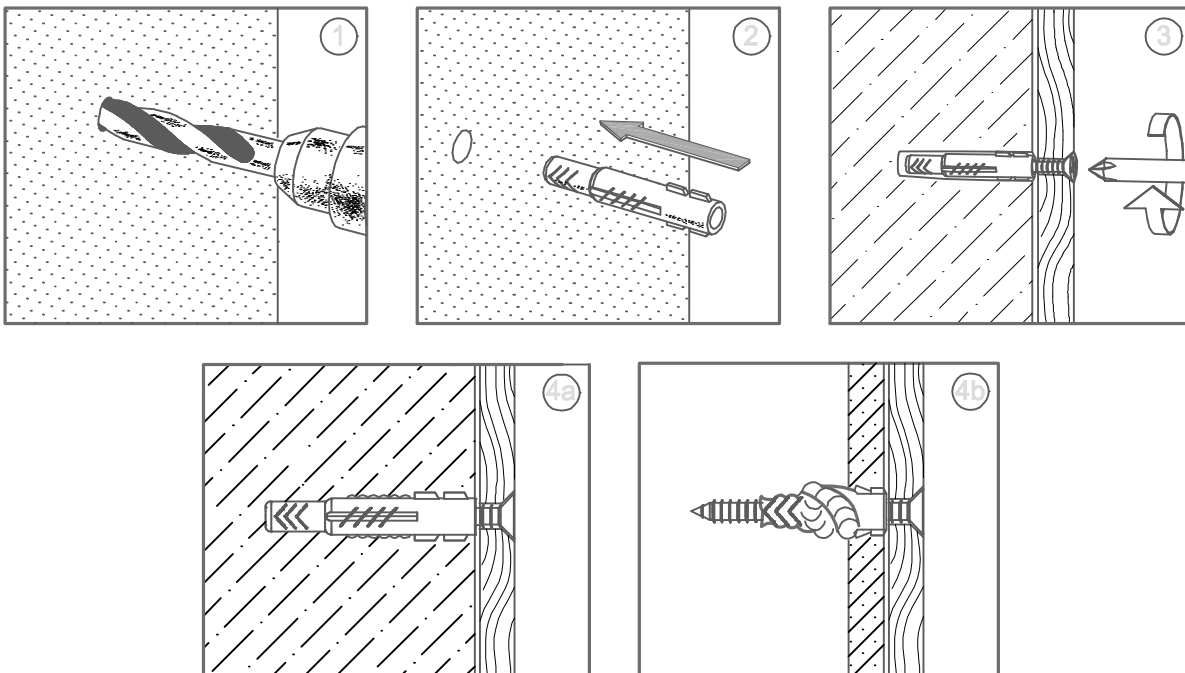
H8 A69 
ø4x60 ø6mm

- D** **Achtung:** Die Befestigung des Möbelstückes an der Wand muss von einer fachkundigen Person vorgenommen werden, da für die Montage an die Wand angepasste Dübel erforderlich sind.
- GB** **Attention:** A qualified professional is required when mounting furniture to the wall since dowels corresponding to the wall are required for this.
- FR** **Attention :** La fixation du meuble contre le mur doit être effectuée par une personne compétente car, pour le montage mural, il faut utiliser des chevilles adaptées.
- IT** **Attenzione:** Il fissaggio del mobile alla parete deve essere eseguito da persone esperte, dato che occorrono tasselli adeguati.
- NL** **Opgelet:** een vakkundige persoon dient het meubelstuk aan de muur te bevestigen; voor de montage aan de muur zijn immers aangepaste pluggen vereist.
- PL** **Uwaga:** Mocowanie mebla do ściany mogą przeprowadzić wyłącznie wykwalifikowane osoby, z uwagi na zastosowanie odpowiednio dopasowanych kołków do rodzaju ściany.
- CZ** **Pozor:** Montáž nábytku na stěnu musí provést odborník, protože k montáži na stěnu jsou zapotřebí upravené hmoždinky.
- SK** **Pozor:** Upevnenie nábytku na stenu musí vykonať odborník, nakoľko sú pre montáž na stenu potrebné vhodné hmoždinky.
- HU** **Figyelem:** A bútorelemek falra rögzítését szakembernek kell végeznie, mert a rögzítéshez megfelelő tiplít kell használni.
- RO** **Atenție:** Fixarea la perete a piesei de mobilier se realizează numai de către personal competent, deoarece montajul de perete necesită dibluri adecvate.
- TR** **Dikkat:** Mobilya parçasının duvara sabitlenmesi, duvar montajı için özel uyarlanmış dübeller gerektirdiğinden bu iş sadece bu konuda uzman bir kişi tarafından gerçekleştirilmelidir.
- RU** **Внимание:** Поскольку для монтажа на стене необходимо использовать специальные дюбели, мебель должна быть закреплена на стене квалифицированным персоналом.