

# Aufbauanleitung

Assembly plan

Instructions de montage

Instrucciones de montaje

Istruzioni di montaggio

Montagevoorschrift



## Wickelkommode 'Lumi' breit

Changing unit 'Lumi' wide • Commode à langer 'Lumi' large • Cambiador 'Lumi' ancho • Fasciatoio 'Lumi' largo  
• Commode 'Lumi' breed

Jetzt unter [garantie.pinolino.de](http://garantie.pinolino.de)  
registrieren und **10 Jahre**  
**Pinolino-Plus-Garantie** sichern!



ohne Dekoration  
without decoration  
sans décoration  
sin decoración  
senza decorazione  
zonder decoratie

Art.-Nr. • Item No. • N° d'art. 13 00 32 B

Dekor: Uni, weiß und Eiche mit Echtholzstruktur • Decor: Plain, white and oak with natural wood texture • Décor: Uni, blanc et chêne avec texture de bois véritable • Decoración: Unicolor, blanco y roble con estructura de madera • Decorazione: Tinta unita, bianco e quercia con struttura in legno • Decor: Uni, wit en eiken met echte houtstructuur

# WICHTIG, FÜR SPÄTERE VERWENDUNG AUFBEWAHREN: SORGFÄLTIG LESEN.



Nur im kompletten Aufbau als Wickelkommode zu verwenden!

Schön, dass du dich für Pinolino entschieden hast! Wir haben diesen Artikel mit großer Sorgfalt und nach den strengen Auflagen der Europäischen Sicherheitsnormen hergestellt. Bitte lies dir die Aufbauanleitung sorgfältig durch und kontrolliere die Vollständigkeit der mitgelieferten Teile. Bei unsachgemäßer Bedienung oder Montage und insbesondere bei Veränderungen der Konstruktion erlischt der Garantieanspruch.

## Sicherheitshinweis:

Bitte überzeuge dich regelmäßig vom festen Sitz aller Schrauben und Verbindungsmittel und ziehe diese bei Bedarf nach. Diesen Artikel bitte nicht benutzen, falls nicht alle Bauteile einwandfrei angebracht und eingestellt sind, wenn irgendein Teil defekt ist, abgerissen ist, oder fehlt. Nur original Zubehör- und Ersatzteile verwenden. Kunststoffbeutel und etwaige Kunststoffelemente / Verpackungen sind sofort zu entfernen oder für Kinder unzugänglich aufzubewahren! Lege während des Aufbaus eine geeignete Unterlage unter die Bauteile, um das Produkt und deinen Fußboden vor Beschädigungen zu schützen. Um Beschädigungen am Produkt zu vermeiden, darf zum Anschrauben der Beschläge kein Akkuschrauber verwendet werden. Denke an das Risiko von offenem Feuer und anderen starken Wärmequellen in der unmittelbaren Umgebung der Wickeleinrichtung, wie elektrische Heizstrahler, gasbeheizte Öfen usw. Benutze eine Wickelunterlage in der Größe 85 x 75 cm und befestige diese mit doppelseitigen Klebeband oder selbstklebendem Klettband auf der Wickelkommode. Die Wickelkommode muss für den sicheren Gebrauch des Produktes an der Wand befestigt werden. Die verwendete Befestigung muss für deine Wand geeignet sein, lasse dich im Fachhandel beraten. Die Wickelkommode ist für Kinder bis 15 kg geeignet.

## Warnung:

- Lassen Sie Ihr Kind nicht unbeaufsichtigt.



## Produktinweis:

Dieser Artikel ist teilweise aus Holz gefertigt. Unregelmäßigkeiten in Struktur und Farbe sind typische Merkmale des natürlichen Rohstoffes und begründen keinen Mangel. Bei der Herstellung unserer Produkte werden ausschließlich Öle, Lacke und Lasuren verarbeitet, die gesundheitlich unbedenklich und speziell für Kinder geeignet sind. Manchmal kann es produktionsbedingt zu Geruchsentwicklungen durch die fabrikneuen Möbel kommen. In diesem Falle empfehlen wir dieser ungefährlichen Geruchsbelästigung durch mehrmaliges Stoßlüften entgegenzuwirken. Weitere Informationen zur Pflege und Reinigung findest du unter [www.pinolino.de](http://www.pinolino.de).

## 10 Jahre Garantie sichern!

Registrierte jetzt dein Pinolino Produkt schnell und unkompliziert unter [garantie.pinolino.de](http://garantie.pinolino.de) und sichere dir damit die 10 Jahre Pinolino-Plus-Garantie.

## Wie können wir dir helfen?

Es ist uns ein großes Anliegen, dir schnell und auf direktem Weg zu helfen, wenn du Hilfe mit einem Pinolino Produkt oder Ersatz für einzelne Bauteile oder Schrauben benötigst. Fülle dafür bitte das Formular unter [www.pinolino.de/servicefallaus](http://www.pinolino.de/servicefallaus).

JETZT DIREKT REGISTRIEREN

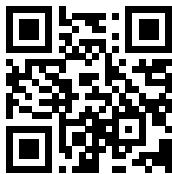

# IMPORTANT, KEEP FOR FUTURE USE: READ CAREFULLY.



Only use as changing unit if completely assembled!

Thank you for choosing Pinolino! We have produced this article with great care and according to strict requirements of European safety standard. Please read the set-up instructions carefully and check the delivered parts' completeness. In case of improper handling or installation and especially changes to the construction the guarantee will be lost.

## Safety advice:

Please check regularly that all screws and fasteners are tight and tighten them if necessary. Please do not use this item if all components are not properly fitted and adjusted, if any part is defective, torn off or missing. Use only original accessories and spare parts. Plastic bags and any plastic elements / packaging must be removed immediately or kept out of reach of children! During assembly, place a suitable base under the components to protect the product and your floor from damage. To avoid damage to the product, do not use a cordless screwdriver to screw on the fittings. Be aware of the risk of naked flames and other sources of intense heat in the immediate vicinity of the wrapping unit, such as electric heaters, gas-fired ovens, etc. Use an 85 x 75 cm changing mat and attach it to the changing unit with double-sided tape or self-adhesive Velcro. The changing unit must be fixed to the wall for safe use of the product. The fastening used must be suitable for your wall, ask a specialist shop for advice. The changing unit is suitable for children up to 15 kg.

## Warning:

-Do not leave your child unattended.

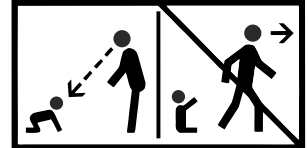

## Product notice:

This item is partly made of wood. Irregularities in structure and colour are typical characteristics of the natural raw material and do not constitute a defect. In the manufacture of our products we only use oils, lacquers, and glazes that are harmless to health and especially suitable for children. Sometimes, there might be a development of unpleasant smells from the brand-new furniture due to the production process. In this case, we recommend airing the room several times a day. The smell is harmless. Further information regarding care and cleaning can be found on [www.pinolino.de](http://www.pinolino.de).

## Get 10 years warranty!

Go straight up to [warranty.pinolino.com](http://warranty.pinolino.com) and register your Pinolino product. After registration you are eligible for 10 years warranty.

REGISTER NOW



## How can we help you?

It is very important to us that we can help you quickly and directly. If you need help with a Pinolino product, need a spare part for a single component or if you need screws, please fill in the form on [www.pinolino.de/servicefall](http://www.pinolino.de/servicefall).



# IMPORTANT, À CONSERVER POUR UNE UTILISATION POSTÉRIEURE : LIRE ATTENTIVEMENT.

F

Utiliser comme une commode à langer seulement si elle est complètement assemblée!

Nous sommes ravis que vous ayez choisi Pinolino ! Nous avons fabriqué cet article avec le plus grand soin et selon les conditions strictes des normes de sécurité européennes. Veuillez lire attentivement les instructions de montage et contrôlez l'intégralité des pièces fournies. En cas d'utilisation ou de montage non conforme et en particulier en cas de modification de la construction, le droit à la garantie est annulé.

## Consigne de sécurité :

Vérifiez régulièrement que toutes les vis et tous les moyens de fixation sont bien serrés et resserrez-les si nécessaire. Ne pas utiliser cet article si tous les composants ne sont pas correctement installés et réglés, si une pièce est défectueuse, arrachée ou manquante. N'utiliser que des accessoires et des pièces de rechange d'origine. Les sacs en plastique et les éventuels éléments/emballages en plastique doivent être retirés immédiatement ou tenus hors de portée des enfants ! Pendant le montage, placez un support approprié sous les éléments afin de protéger le produit et votre sol contre les dommages. Pour éviter d'endommager le produit, n'utilisez pas de visseuse sans fil pour visser les ferrures. Pensez au risque de feu ouvert et à d'autres sources de chaleur importantes dans l'environnement immédiat du dispositif d'enrobage, comme les radiateurs électriques, les fours chauffés au gaz, etc. Utilisez un matelas à langer de 85 x 75 cm et fixez-le sur la table à langer avec du ruban adhésif double face ou du velcro autocollant. La table à langer doit être fixée au mur pour une utilisation sûre du produit. La fixation utilisée doit être adaptée à ton mur, demande conseil dans un magasin spécialisé. La table à langer convient aux enfants pesant jusqu'à 15 kg.

## Attention:

- Ne laissez pas votre enfant sans surveillance.

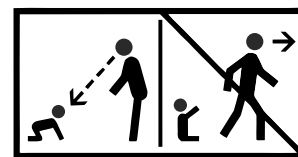

## Remarque sur le produit :

Cet article est partiellement fabriqué en bois. Les irrégularités de structure et de couleur sont des caractéristiques de la matière première naturelle et ne constituent pas un défaut. Lors de la fabrication de nos produits, nous utilisons des huiles, de vernis et des lasures qui ne présentent aucun risque pour la santé et qui sont spécialement adaptés aux enfants. Parfois, les meubles neufs peuvent être malodorants en raison de la production. Dans ce cas, nous recommandons une aération régulière pour éviter les odeurs désagréables qui ne sont pas dangereuses. Pour plus d'informations sur l'entretien et le nettoyage, voir [www.pinolino.de](http://www.pinolino.de).

## Assurez-vous de 10 ans de garantie !

Enregistrez votre produit Pinolino rapidement et sans complication en ligne sur [warranty.pinolino.com](http://warranty.pinolino.com) et profitez ainsi de la garantie Pinolino Plus de 10 ans.

## Comment pouvons-nous vous aider ?

Il nous tient à cœur de vous aider rapidement et directement si vous avez besoin d'aide avec un produit Pinolino ou si vous avez besoin d'une pièce de rechange ou des vis. Pour ce faire, veuillez remplir le formulaire sur [www.pinolino.de/servicefall](http://www.pinolino.de/servicefall).

S'INSCRIRE DIRECTEMENT



# ¡IMPORTANTE - LEERSE ATENTAMENTE! - GUARDAR PARA UTILIZACIÓN POSTERIOR



¡CÓMODA VA DE EMPLEARSE COMO TAL, SÓLO EN CASO DE QUE ES MONTADA ENTERAMENTE!

Nos alegramos de que haya elegido Pinolino. Hemos fabricado este artículo con gran cuidado y de acuerdo con los estrictos requisitos de las normas de seguridad europeas. Lea atentamente las instrucciones de montaje y compruebe que las piezas suministradas están completas. El uso o el montaje inadecuados, y en particular las modificaciones de la construcción, invalidarán la garantía.

## Consejos de seguridad:

Por favor, compruebe regularmente que todos los tornillos y fijaciones están apretados y apriételes si es necesario. Por favor, no utilice este artículo si todos los componentes no están bien montados y ajustados, si alguna pieza está defectuosa, arrancada o falta. Utilice únicamente accesorios y piezas de recambio originales. Las bolsas de plástico y todos los elementos de plástico/embalajes deben retirarse inmediatamente o mantenerse fuera del alcance de los niños. Durante el montaje, coloque una base adecuada debajo de los componentes para proteger el producto y su suelo de posibles daños. Para evitar daños en el producto, no utilice un destornillador inalámbrico para atornillar los accesorios. Tenga en cuenta el riesgo de llamas desnudas y otras fuentes de calor intenso en las inmediaciones de la unidad de envoltura, como calentadores eléctricos, hornos de gas, etc. Utiliza un cambiador de 85 x 75 cm y fíjalo al cambiador con cinta adhesiva de doble cara o velcro autoadhesivo. El cambiador debe estar fijado a la pared para un uso seguro del producto. La fijación utilizada debe ser adecuada para su pared, pida consejo a una tienda especializada. El cambiador es adecuado para niños de hasta 15 kg.

## Advertencia:

-No deje a su hijo sin vigilancia.

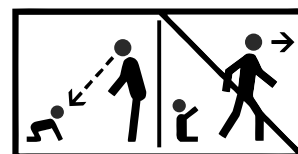

## Aviso sobre el producto:

Este artículo es en parte de madera. Las irregularidades en la estructura y el color son características típicas de la materia prima natural y no constituyen un defecto. En la fabricación de nuestros productos sólo se utilizan aceites, barnices y tintes inocuos para la salud y especialmente adecuados para los niños. A veces, debido al proceso de producción, los muebles fabricados en fábrica pueden desprender olores. En este caso, se recomienda contrarrestar esta inofensiva molestia de olor ventilando el mueble varias veces. Encontrará más información sobre el cuidado y la limpieza en [www.pinolino.de](http://www.pinolino.de).

## ¡Asegure una garantía de 10 años!

Registre ahora su producto Pinolino de forma rápida y sencilla en [warranty.pinolino.com](http://warranty.pinolino.com) y asegúrese la garantía Pinolino Plus de 10 años.

## ¿Cómo podemos ayudarle?

Es muy importante para nosotros ayudarle de forma rápida y directa si necesita ayuda con un producto Pinolino o una sustitución de componentes o tornillos individuales. Rellene el formulario en [www.pinolino.de/servicefall](http://www.pinolino.de/servicefall).

REGÍSTRESE DIRECTAMENTE AHORA

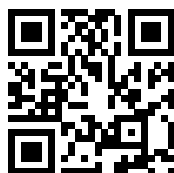

# IMPORTANTE - LEGGERE ATTENTAMENTE! - CONSERVARE PER FUTURI RIFERIMENTI

IT

Il fasciatoio sarà utilizzato come tale, solo se è assemblato per intero!

Siamo lieti che abbiate scelto Pinolino! Abbiamo prodotto questo articolo con grande cura e secondo i severi requisiti delle norme di sicurezza europee. Leggere attentamente le istruzioni di montaggio e verificare che le parti fornite siano complete. L'uso o il montaggio improprio, e in particolare le modifiche alla costruzione, invalidano la garanzia.

## Consigli per la sicurezza:

Controllare regolarmente che tutte le viti e gli elementi di fissaggio siano serrati e, se necessario, stringerli. Non utilizzare questo articolo se tutti i componenti non sono montati e regolati correttamente, se qualche parte è difettosa, strappata o mancante. Utilizzare solo accessori e ricambi originali. I sacchetti di plastica e tutti gli elementi/imballaggi in plastica devono essere rimossi immediatamente o tenuti fuori dalla portata dei bambini! Durante il montaggio, posizionare una base adeguata sotto i componenti per proteggere il prodotto e il pavimento da eventuali danni. Per evitare di danneggiare il prodotto, non utilizzare un cacciavite a batteria per avvitare i raccordi. Prestare attenzione al rischio di fiamme libere e di altre fonti di calore intenso nelle immediate vicinanze dell'apparecchiatura di confezionamento, come stufe elettriche, forni a gas, ecc. Utilizzare un fasciatoio di 85 x 75 cm e fissarlo al fasciatoio con nastro biadesivo o velcro autoadesivo. Per un utilizzo sicuro del prodotto, l'unità di cambio deve essere fissata alla parete. Il fissaggio utilizzato deve essere adatto alla vostra parete; chiedete consiglio a un negozio specializzato. Il fasciatoio è adatto a bambini fino a 15 kg.

## Attenzione:

- Non lasciate il bambino incustodito.

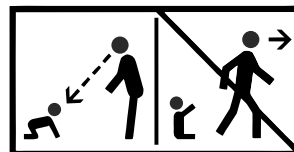

## Avviso sul prodotto:

Questo articolo è realizzato in parte in legno. Le irregolarità nella struttura e nel colore sono caratteristiche tipiche della materia prima naturale e non costituiscono un difetto. Per la fabbricazione dei nostri prodotti utilizziamo solo oli, vernici e smalti innocui per la salute e particolarmente adatti ai bambini. A volte, a causa del processo di produzione, si possono sviluppare odori dai mobili fabbricati in fabbrica. In questo caso, si consiglia di contrastare questo fastidioso odore innocuo arieggiando più volte il mobile. Ulteriori informazioni sulla cura e la pulizia sono disponibili sul sito [www.pinolino.de](http://www.pinolino.de).

## Assicuratevi una garanzia di 10 anni!

Registra subito il tuo prodotto Pinolino in modo semplice e veloce su [warranty.pinolino.com](http://warranty.pinolino.com) e assicurati la garanzia di 10 anni Pinolino Plus.

## Come possiamo aiutarvi?

Per noi è molto importante aiutarvi in modo rapido e diretto se avete bisogno di assistenza per un prodotto Pinolino o per la sostituzione di singoli componenti o viti. Compilare il modulo all'indirizzo [www.pinolino.de/servicefall](http://www.pinolino.de/servicefall).

REGISTRATI DIRETTAMENTE ORA

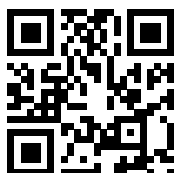

# BELANGRIJK - ZORGVULDIG LEZEN!- VOOR LATERE RAADPLEGING BEWAREN



Alleen compleet gemonteerd als babycommode te gebruiken!

Wij zijn blij dat u voor Pinolino gekozen heeft! Wij hebben dit artikel met grote zorg en volgens de strenge eisen van de Europese veiligheidsnormen vervaardigd. Lees de montage-instructies zorgvuldig door en controleer of de geleverde onderdelen compleet zijn. Ondeskundig gebruik of montage, en in het bijzonder wijzigingen aan de constructie, maken de garantie ongeldig.

## Veiligheidsadvies:

Controleer regelmatig of alle schroeven en bevestigingsmiddelen stevig vastzitten en draai ze zo nodig aan. Gebruik dit artikel niet als niet alle onderdelen juist zijn gemonteerd en afgesteld, als een onderdeel defect is, afgescheurd of ontbreekt. Gebruik alleen originele accessoires en reserveonderdelen. Plastic zakken en alle plastic elementen / verpakkingen moeten onmiddellijk worden verwijderd of buiten het bereik van kinderen worden gehouden! Plaats tijdens de montage een geschikte ondergrond onder de onderdelen om het product en uw vloer tegen beschadiging te beschermen. Om beschadiging van het product te voorkomen, mag u geen accuschroevendraaier gebruiken om de fittingen vast te schroeven. Wees u bewust van het risico van open vuur en andere bronnen van intense hitte in de onmiddellijke nabijheid van de inpakapparatuur, zoals elektrische kachels, ovens op gas, enz. Gebruik een aankleedkussen van 85 x 75 cm en bevestig het aan de verschoonunit met dubbelzijdige tape of zelfklevend klittenband. Voor een veilig gebruik van het product moet de luiertafel aan de muur worden bevestigd. De gebruikte bevestiging moet geschikt zijn voor uw muur, vraag een gespecialiseerde winkel om advies. De verschoonunit is geschikt voor kinderen tot 15 kg.

## Waarschuwing:

- Laat uw kind niet zonder toezicht achter.

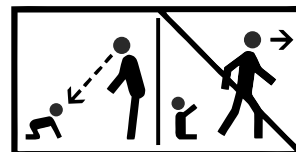

## Product mededeling:

Dit artikel is gemaakt gedeeltelijk van hout. Onregelmatigheden in structuur en kleur zijn typische kenmerken van de natuurlijke grondstof en vormen geen gebrek. Voor de vervaardiging van onze producten gebruiken wij uitsluitend oliën, vernissen en glazuren die onschadelijk zijn voor de gezondheid en bijzonder geschikt voor kinderen. Soms kunnen er, als gevolg van het productieproces, geuren ontstaan uit de in de fabriek vervaardigde meubelen. In dat geval raden wij aan deze onschadelijke geurhinder tegen te gaan door het meubel meerdere malen te luchten. Meer informatie over onderhoud en reiniging is te vinden op [www.pinolino.de](http://www.pinolino.de).

## Verzekeer u van 10 jaar garantie!

Registreer uw Pinolino product nu snel en eenvoudig op [warranty.pinolino.com](http://warranty.pinolino.com) en verzekeer u van 10 jaar Pinolino Plus garantie.

## Hoe kunnen we u helpen?

Het is voor ons erg belangrijk om u snel en direct te helpen als u hulp nodig heeft met een Pinolino product of een vervanging voor losse onderdelen of schroeven. Vul het formulier in op [www.pinolino.de/servicefall](http://www.pinolino.de/servicefall).

REGISTREER NU DIRECT



Artikelmaß • Product size • Dimensions de l'article • Mediciones producto • Dimensioni del prodotto • Artikelafmetingen

Karton • Pack • Carton • Embalaje • Confezione • Verpakking

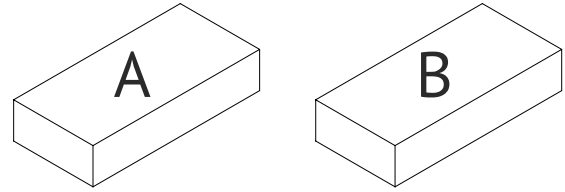
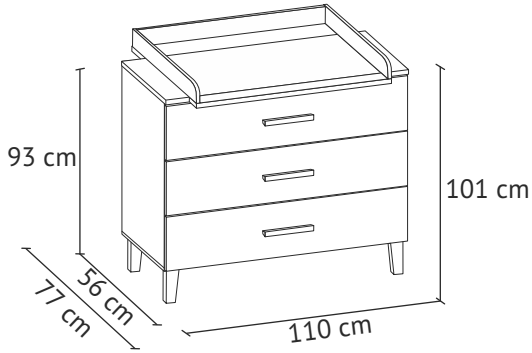

Zubehör zu diesem Artikel • Accessories for this product • Accessoires pour cet article • Accesorios para este producto • Accessori per questo prodotto • Toebehoren voor dit product



Wickelauflagen  
• Changing mat  
• Matelas à langer  
• Almofada de fajar  
• Cuscini per fasciatoio  
• Luiermatras

Weitere Artikel aus diesem Programm • Other products from this program • Autres articles de cette collection • Otros productos de este programa • Altri prodotti della presente collezione • Andere artikels in dit programma



Kinderbett • Cot bed • Lit de bébé évolutif • Cuna • Lettino • Babybed 11 00 32

Wickelkommode extrabreit • Changing unit extra wide • Commode à langer extra large • Cambiador extra ancho • Fasciatoio extra largo • Commode extra breed 13 00 32 X

Kleiderschrank • Wardrobe • Armoire • Armario • Armadio • Kledingkast 14 00 32

Kleiderschrank groß • Wardrobe large • Armoire grande • Armario grande • Guardaroba grande • Kast groot 14 00 32 G



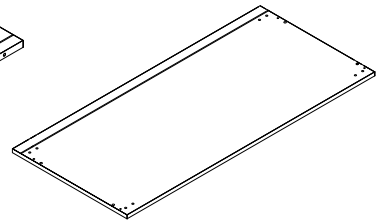
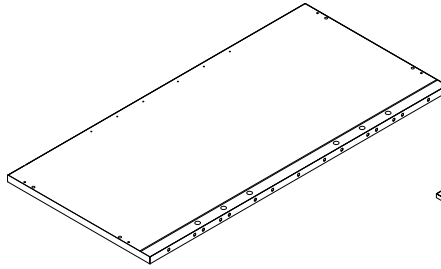
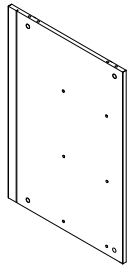
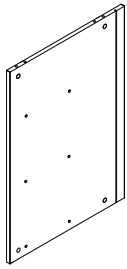

**1 X BL**  
 Seitenteil links  
 Left side panel  
 Panneau latéral gauche  
 Parte lateral izquierda  
 Parte laterale sinistra  
 Zijkant links

**1 X BR**  
 Seitenteil rechts  
 Right side panel  
 Panneau latéral droite  
 Parte lateral derecha  
 Parte laterale destra  
 Zijkant rechts

**1 X G**  
 Platte oben  
 Upper panel  
 Planche supérieure  
 Placa superior  
 Parte superiore  
 Boven plank

**1 X C**  
 Platte unten  
 Bottom plate  
 Planche inférieure  
 Placa inferior  
 Parte inferiore  
 Onderplank

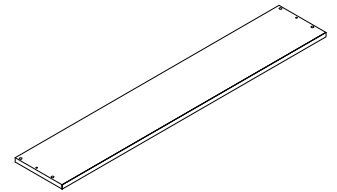
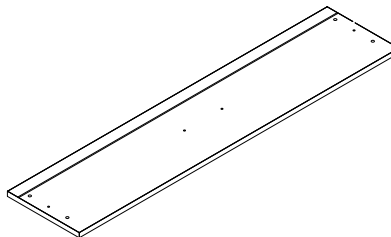
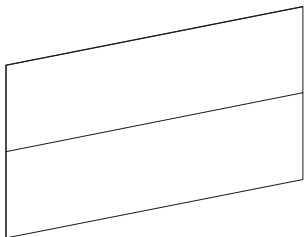

**1 X I**  
 Rückwand  
 Back panel  
 Panneau arrière  
 Panel detrás  
 Pannelo posteriore  
 Achterwand

**4 X F**  
 Fuß  
 Leg  
 Pied  
 Pie  
 Piede  
 Voet

**3 X SV**  
 Schubkastenfront  
 Front drawer panel  
 Front du tiroir  
 Frente cajón  
 Frontalino cassetto  
 Voorkant lade

**3 X SH**  
 Schubkastenrückwand  
 Back drawer panel  
 Panneau arrière du tiroir  
 Detrás cajón  
 Parte posteriore cassetto  
 Achterkant lade

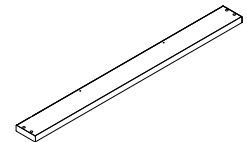
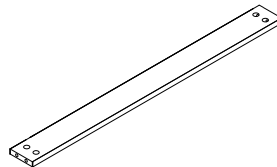
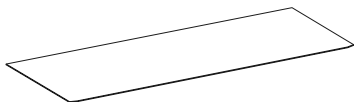
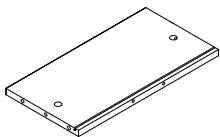

**6 X SS**  
 Schubkastenseitenteil  
 Side panel for drawer  
 Latérale du tiroir  
 Parte lateral cajón  
 Parte laterale cassetto  
 Zijkant lade

**3 X SB**  
 Schubkastenboden  
 Drawer bottom  
 Fond du tiroir  
 Fondo cajón  
 Base cassetto  
 Ladebodem

**1 X KOH**  
 Kranzleiste  
 Crown  
 Latte couronne  
 Corona  
 Cornice  
 Kroon

**1 X GTV**  
 Ansatzbrett vorne  
 Front attachment board  
 Planche supérieure avant  
 Placa adición frente  
 Parte aggiuntiva anteriore  
 Bijvoegplank voor

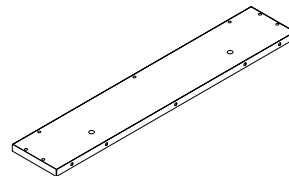
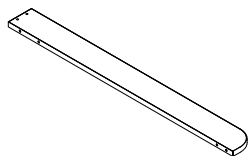
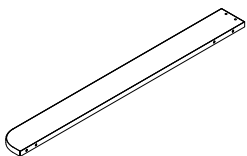

**1 X KOL**  
 Aufsatzleiste links  
 Left attachment slat  
 Latte supérieure gauche  
 Listón de alzamiento izquierda  
 Asse di rialzo sinistra  
 Verhoogtengel links

**1 X KOR**  
 Aufsatzleiste rechts  
 Right attachment slat  
 Latte supérieure droite  
 Listón de alzamiento derecha  
 Asse di rialzo destra  
 Verhoogtengel rechts

**1 X GTH**  
 Ansatzbrett hinten  
 Back attachment board  
 Planche supérieure arrière  
 Placa adición detrás  
 Parte aggiuntiva posteriore  
 Bijvoegplank achter

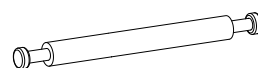
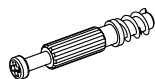
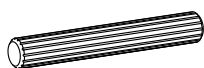
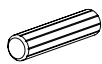

32 X WDH 8/28  
Holzdübel  
Dowel  
Cheville en bois  
Tapón  
Tassello in legno  
Tap

3 X WDH 8/50  
Holzdübel  
Dowel  
Cheville en bois  
Tapón  
Tassello in legno  
Tap

24 X WBC  
Exzenterstift  
Eccentric rod  
Goujon d'assemblage  
Barra excéntrica  
Perno eccentrico  
Excentriek pin

24 X WE 12  
Exzenter  
Eccentric cam  
Boîtier de ferrure  
Excéntrico  
Eccentrico  
Excentriek

2 X WBE  
Bolzen  
Bolts  
Goujon  
Bulón  
Bullone  
Bout

4 X WE 16  
Exzenter  
Eccentric cam  
Boîtier de ferrure  
Excéntrico  
Eccentrico  
Excentriek

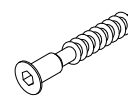
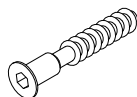

4 X VS 3,5/13  
Holzschraube  
Wood screw  
Vis panneaux  
Tornillo para madera  
Vite per legno  
Houtschroef

6 X VS 3/12  
Holzschraube  
Wood screw  
Vis panneaux  
Tornillo para madera  
Vite per legno  
Houtschroef

4 X VS 4/15  
Holzschraube  
Wood screw  
Vis panneaux  
Tornillo para madera  
Vite per legno  
Houtschroef

11 X VES 6,4/50  
Eckverbinder  
Connecting screw  
Entretoise d'angle à tête plate  
Tornillo de coneccción  
Conformatore  
Hoekverbinder

8 X VES 6,4/40  
Eckverbinder  
Connecting screw  
Entretoise d'angle à tête plate  
Tornillo de coneccción  
Conformatore  
Hoekverbinder

12 X VSC 6,3/13  
Holzschraube  
Wood screw  
Vis panneaux  
Tornillo para madera  
Vite per legno  
Houtschroef

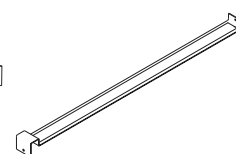
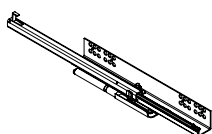
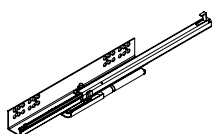

3 X WSD-L  
Führung links  
Left drawer slide  
Coulisse pour tiroir gauche  
Corredera izquierda  
Guida sinistra  
Geleider linksgauche

3 X WSD-R  
Führung rechts  
Right drawer slide  
Coulisse pour tiroir droite  
Corredera derecha  
Guida destra  
Geleider rechts

8 X NK  
Rückwandverbinder  
Back panel connector  
Support de panneau arrière  
Conectador panel  
Giunto pannello posteriore  
Achterwandverbinder

24 X NG 1,6/30  
Nagel  
Nail  
Clou  
Clavo  
Chiodo  
Spijker

3 X HK  
Griff  
Handle  
Poignée  
Mango  
Maniglia  
Handvat

3 X MKUS  
Untere Metalleiste Schubkasten  
Lower metal slat for drawer  
Latte inférieure métallique tiroir  
Listón metálico sostenimiento cajón  
Asse metallica supporto  
Metalen tengel

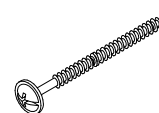
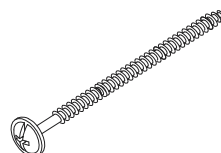
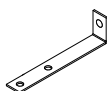

6 X VM 4/22  
Gewindeschraube  
Metric screw  
Vis à tête fraisée bombée  
Tornillo para mango  
Vite per maniglia  
Schroef voor de handvat

2 X WP  
Metallplatte  
Metal plate  
Plaque en métal  
Chapilla metálica  
Piastra metallica  
Metalen plaatje

2 X EML  
Winkel  
Metal bracket  
Équerre  
Escuadra metálica  
Angolo metallico  
Metalen hoek

1 X ET  
Etikette  
Étiquette  
Étiquette  
Etiqueta  
Etichetta  
Etiquette

2 X VS 5/100  
Holzschraube  
Wood screw  
Vis panneaux  
Tornillo para madera  
Vite per legno  
Houtschroef

2 X VS 5/60  
Holzschraube  
Wood screw  
Vis panneaux  
Tornillo para madera  
Vite per legno  
Houtschroef

1 X WI 4  
Inbusschlüssel  
Hex key  
Clé à six pans  
Llave hexagonal  
Chiave a brugola  
Inbussleutel

Zusätzlich benötigtes Werkzeug • Additional necessary tools • Des outils supplémentaires • Otras herramientas necesarias • Altri utensili necessari • Andere benodigde werktuigen

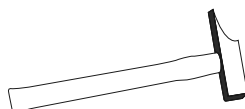

Aufbaupersonen • Persons needed for assembly • Personnes nécessaires au montage • Personas necesarias para montaje • Numero di persone occorrenti per il montaggio • Aantal personen voor de montage



Die Montage muss unbedingt von 2 Erwachsenen durchgeführt werden!  
The assembly must necessarily be carried out by 2 adults!  
Le montage doit être réalisé par 2 adultes!  
¡El montaje va de ser realizado imprescindible por 2 adultos!  
L'assemblaggio dovrà essere eseguito per forza da 2 persone adulte!  
De montage moet noodzakelijkerwijs door 2 volwassenen worden uitgevoerd!

1

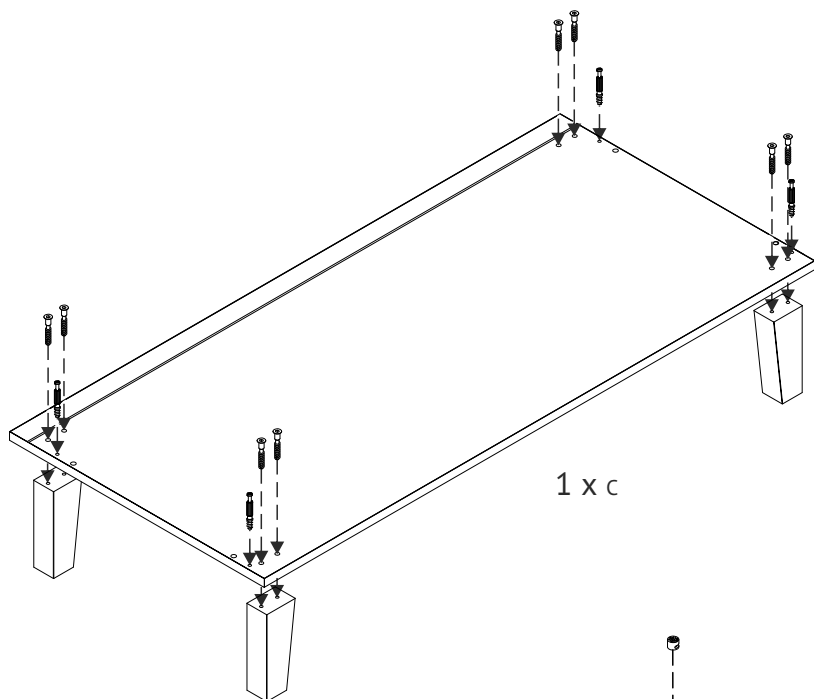

8 X VES 6,4/40

4 X WBC

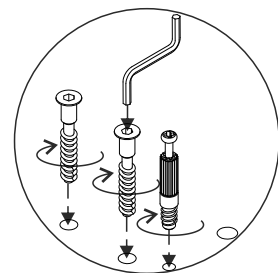

2

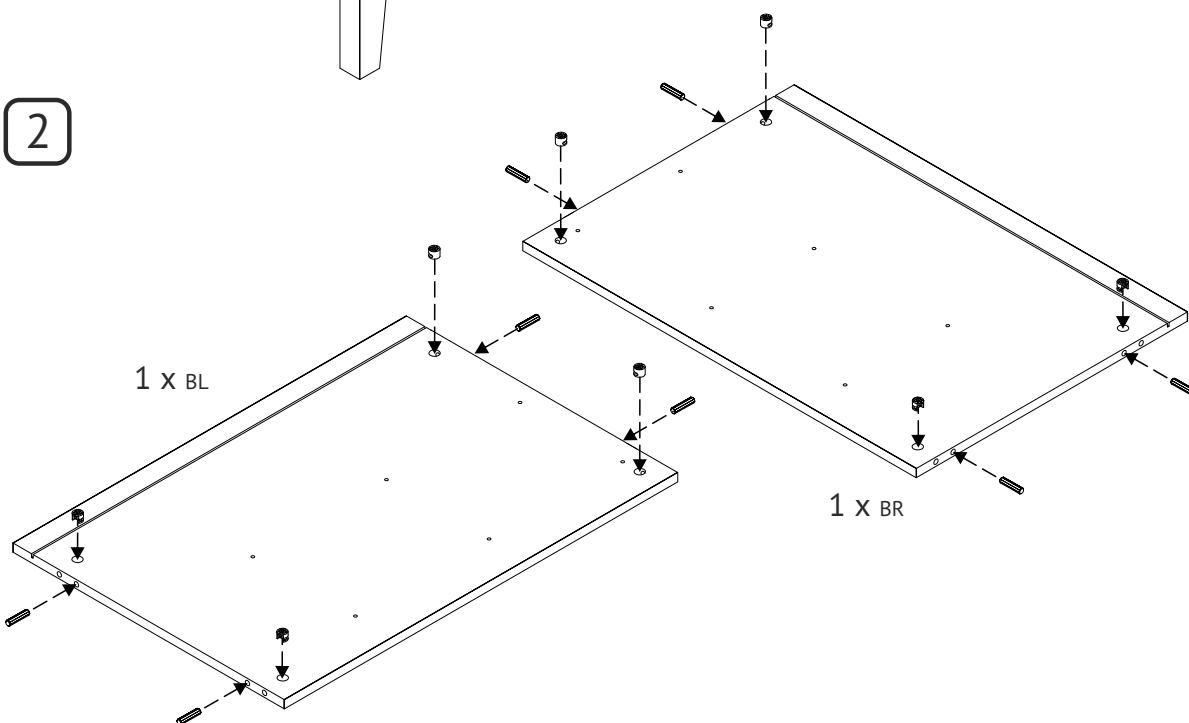

8 X WDH 8/28

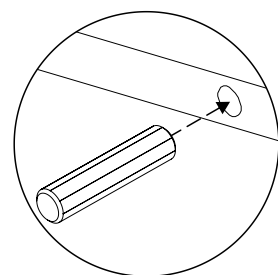

8 X WE 12

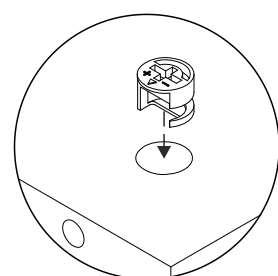

3

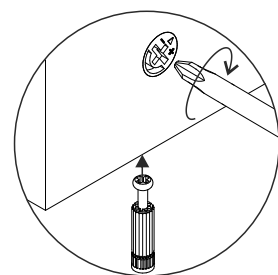
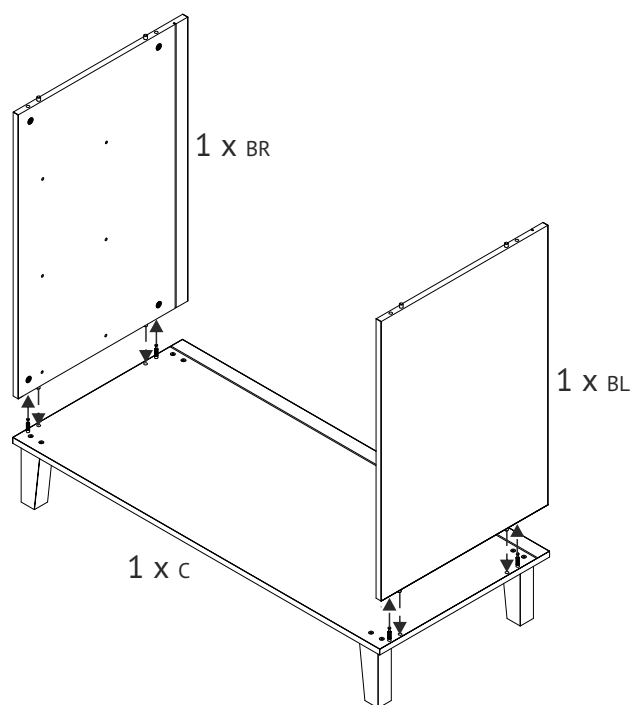

4

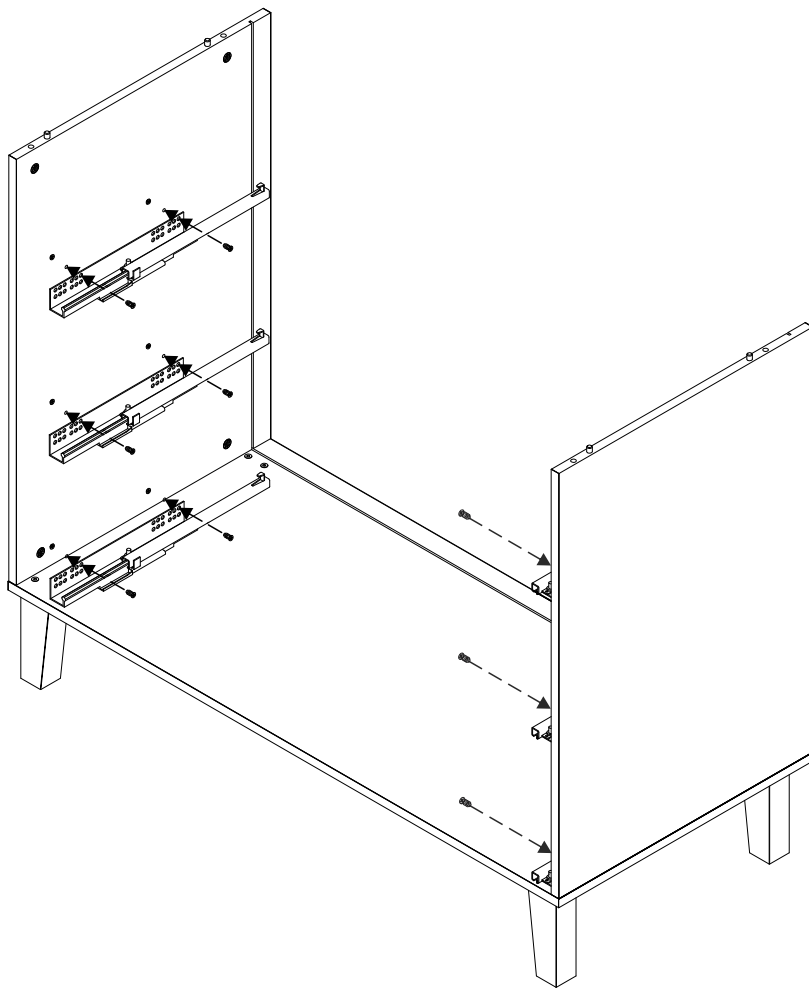

12x VSC 6,3/13

3x WSD-L

3x WSD-R

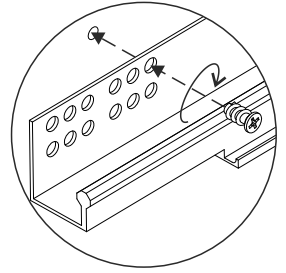

5

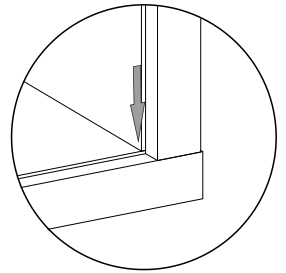
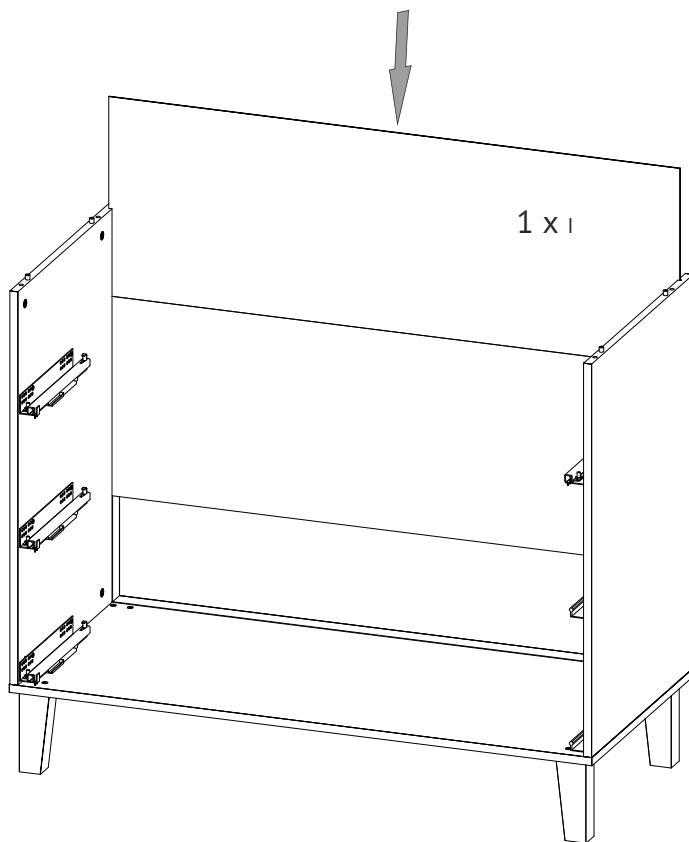

6

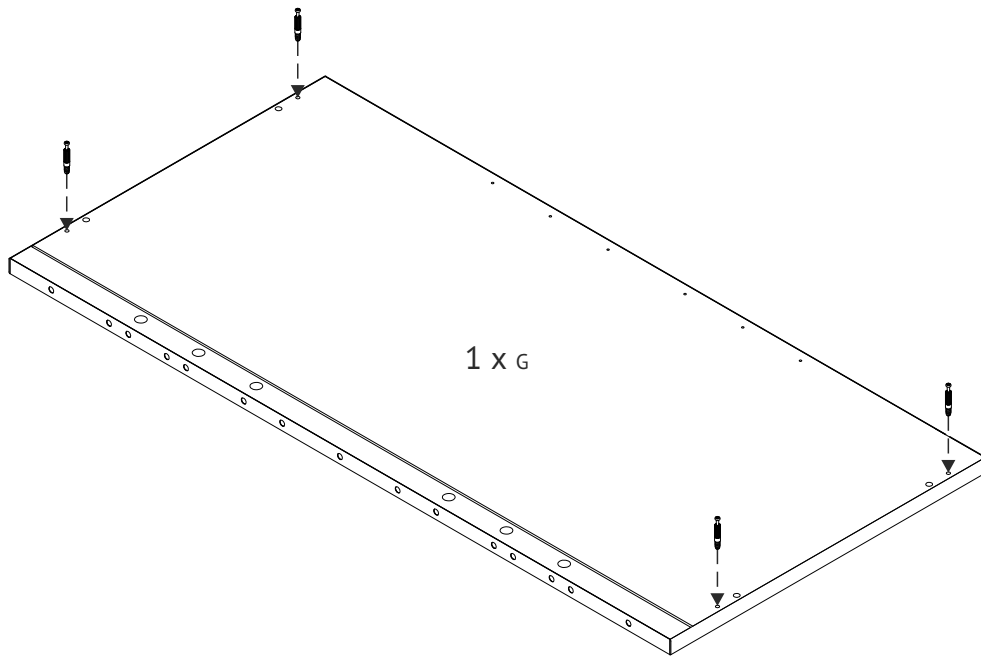

4 x WBC

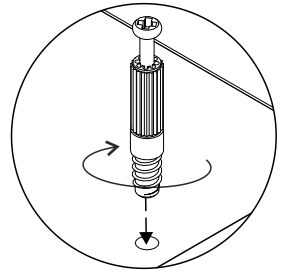

7

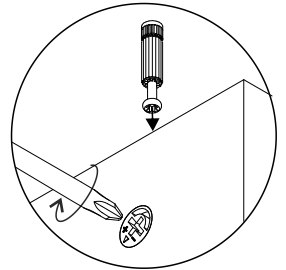
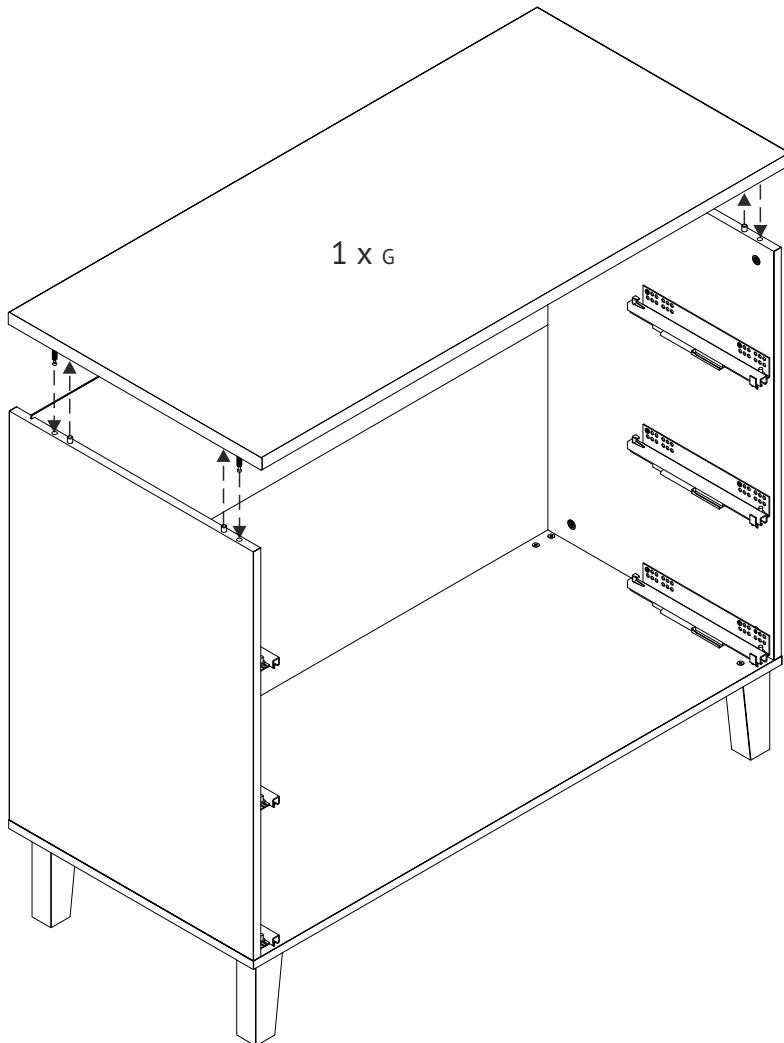

8

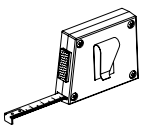

$a = b$

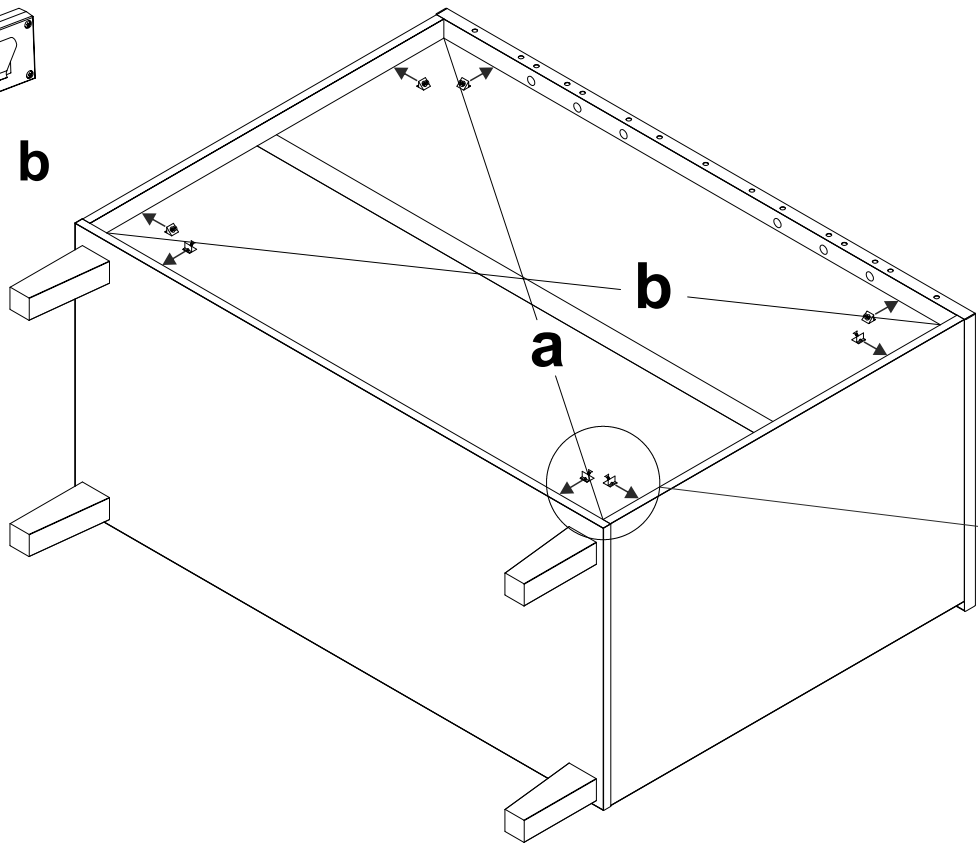

8 x NK

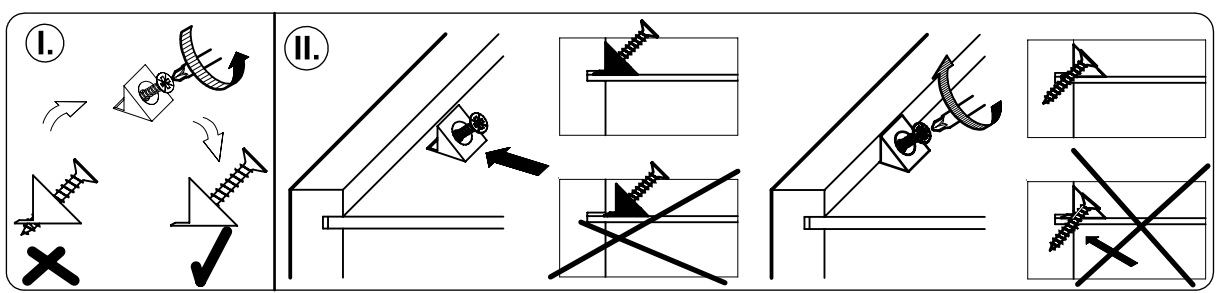
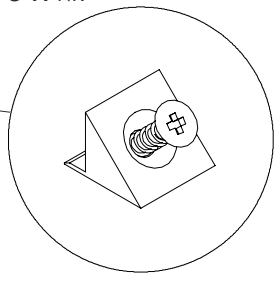

9

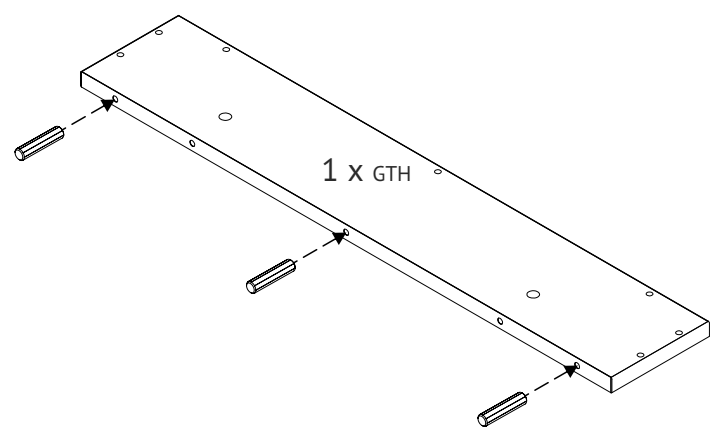

1 x GTH

3 x WDH 8/50

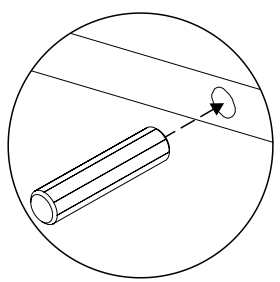

10

- Sie haben verschiedene Möglichkeiten, den Wickelansatz zu montieren.
- There are several options for mounting the attachment board.
- Il ya plusieurs possibilités pour l'assemblage de la planche supérieure arrière.
- Uds tienen varias posibilidades para montar la adición de la placa de fajar.
- Avete varie possibilità di montare l'aggiunta per il fasciatoio.
- U hebt verschillende mogelijkheden om de toevoegsel bij de luiersplank te monteren.

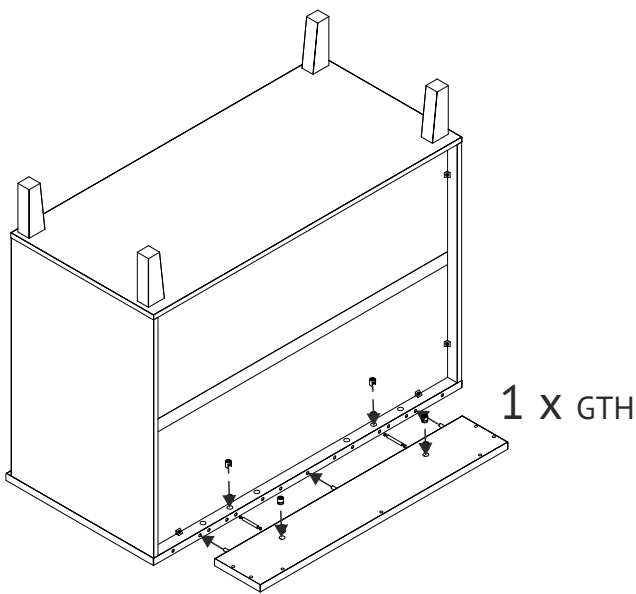

11

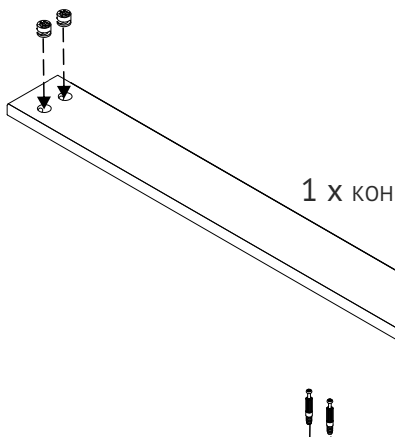

4 X WE 12

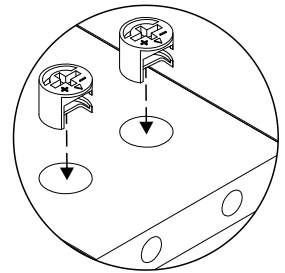

12

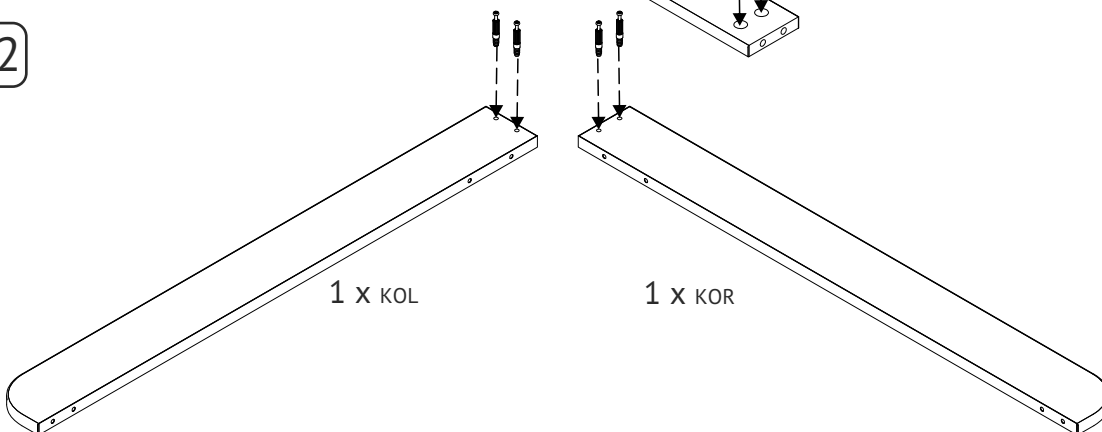

4 X WBC

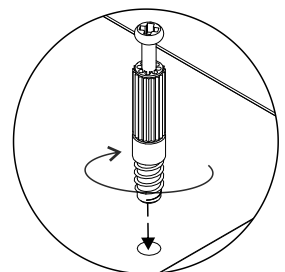

13

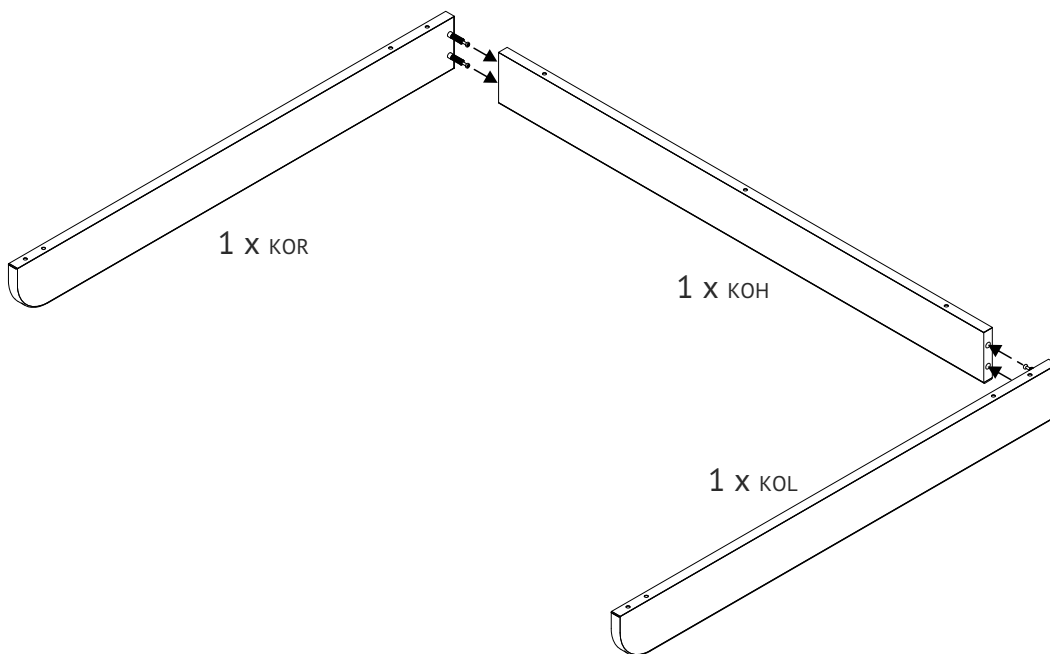

14

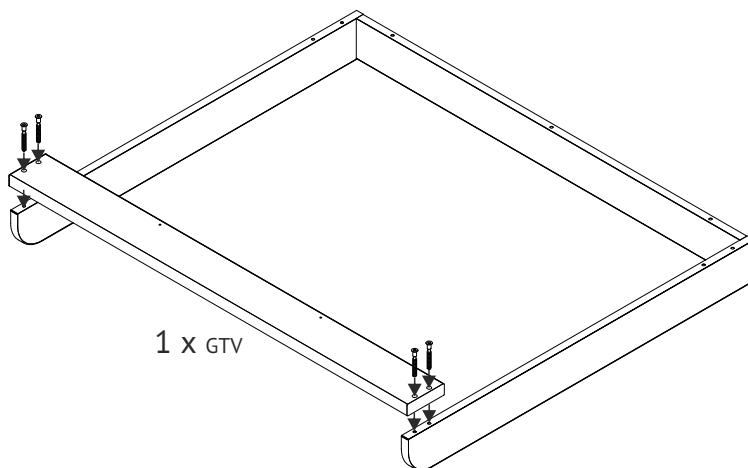

4 x VES 6,4/50

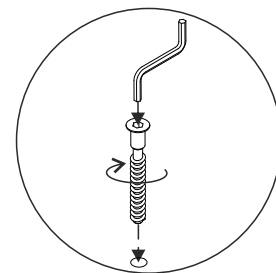

15

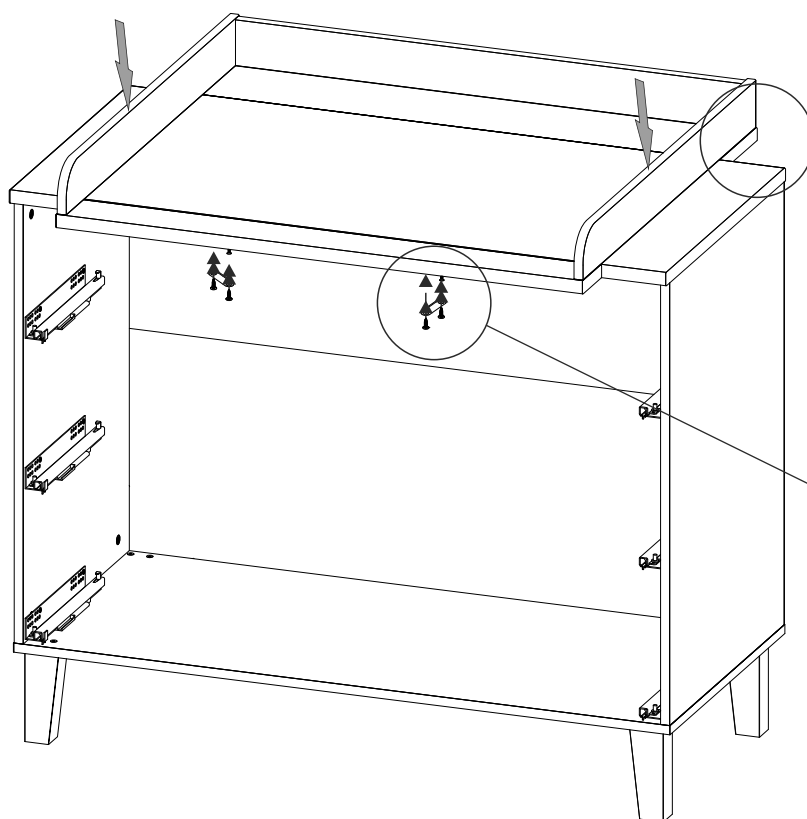

7 x VES 6,4/50

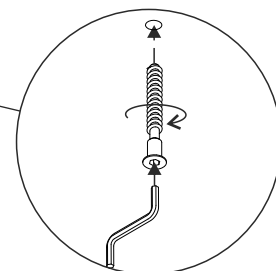

2 x WP  
4 x VS 3,5/13

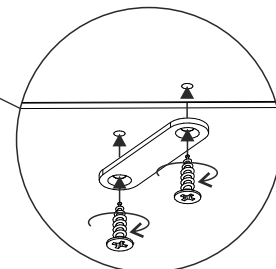



16

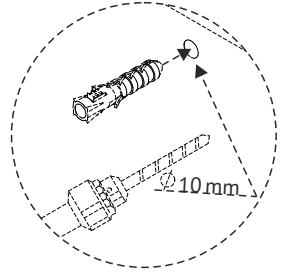
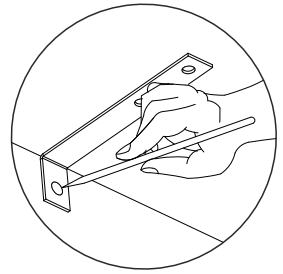
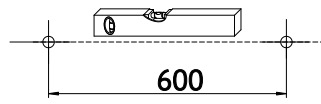
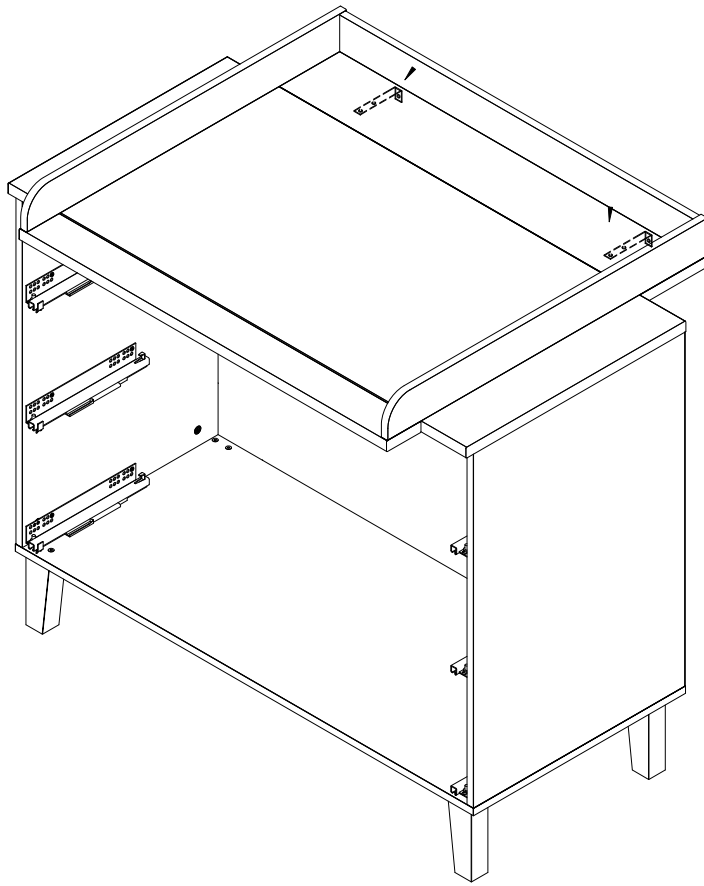

4 X VS 4/15

2 X VS 5/60

2 X EML

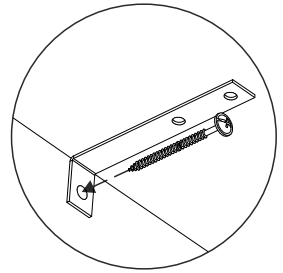
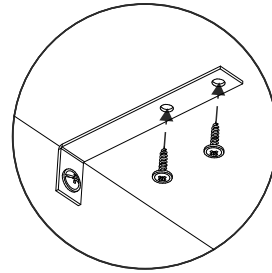

17

3x

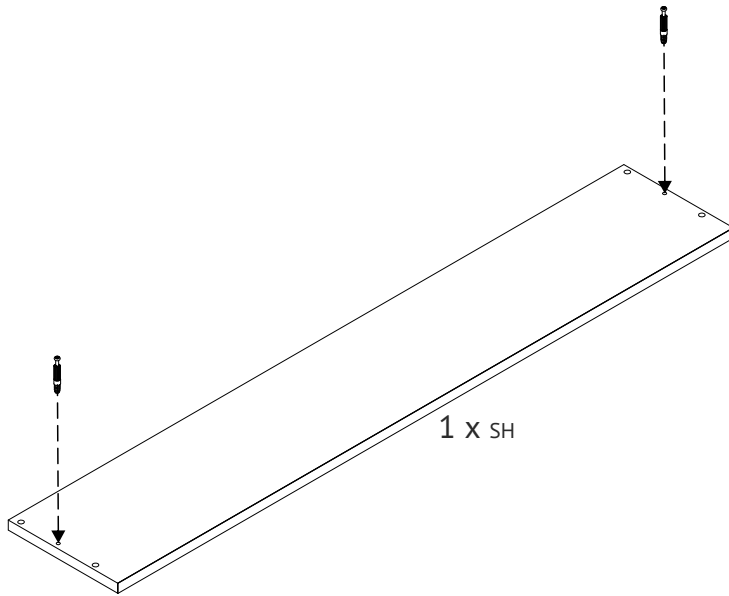

2 X WBC

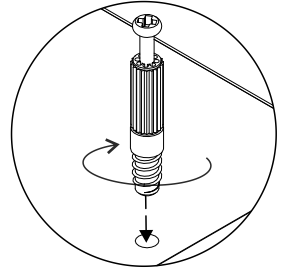

18

6x

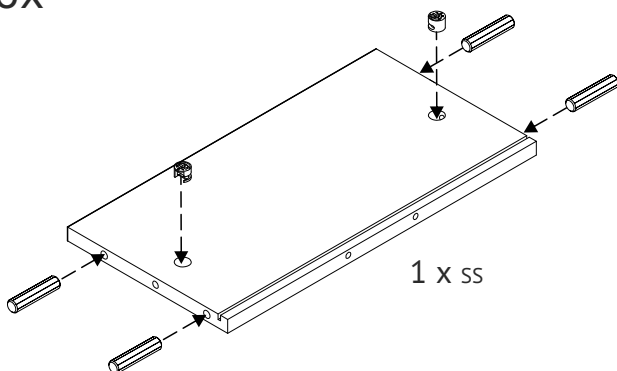

4 X WDH 8/28

2 X WE 12

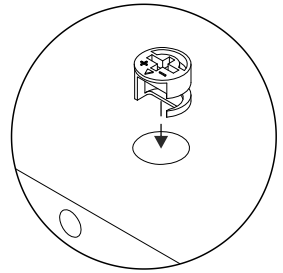
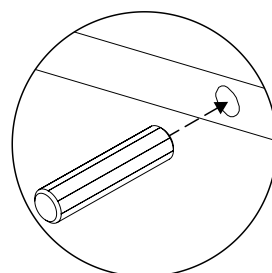

19 3x

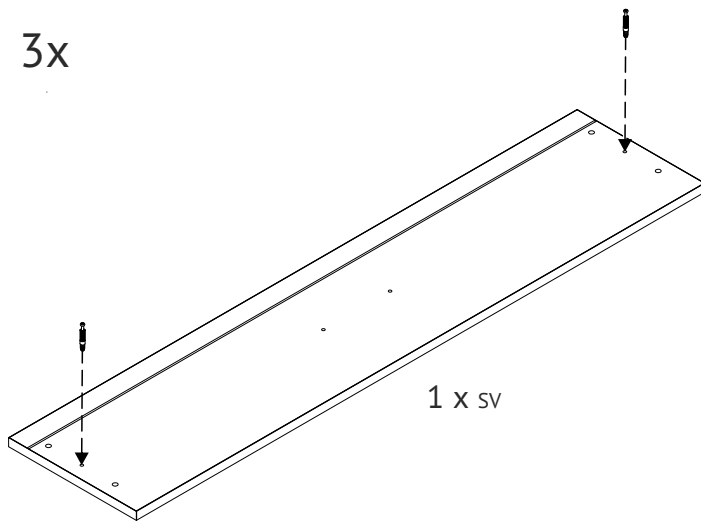

2 x WBC

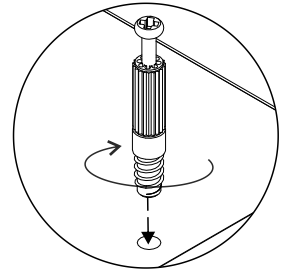

- ! • Verbinden Sie die Schubkastenteile zunächst nur lose miteinander. Ziehen Sie die Schrauben erst fest, nachdem Sie sich davon überzeugt haben, dass die Schubkastenseiten im rechten Winkel montiert sind.
- First, connect the drawerparts loosely. Tighten the screws only after having convinced yourself that the drawersides are in a rightangle.
- Pendant l'assemblage du tiroir, les vis doivent être un peu lâches. Visser fortement les pièces seulement après vous avoir convaincu que les panneaux de côté sont installés à angle droit.
- Ensamblen las piezas del cajón ligero. Apreten los tornillos sólo después de que se han aseguradoUds que las piezas del cajón se encuentran montadas en ángulo derecho.
- Collegare i pezzi del cassetto senza serrarli. Serrare le viti soltanto dopo che vi assicurati che i pezzi del cassetto sianoassemblati in angolo retto.
- De onderdelen van de losse la verbinden. Maak de schroeven vast nadat u gecheckt heeft dat de onderdelen van de la in eenrechte hoek gemonteerd zijn.

20 3x

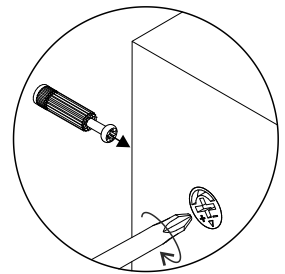
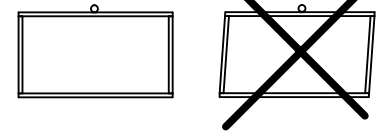
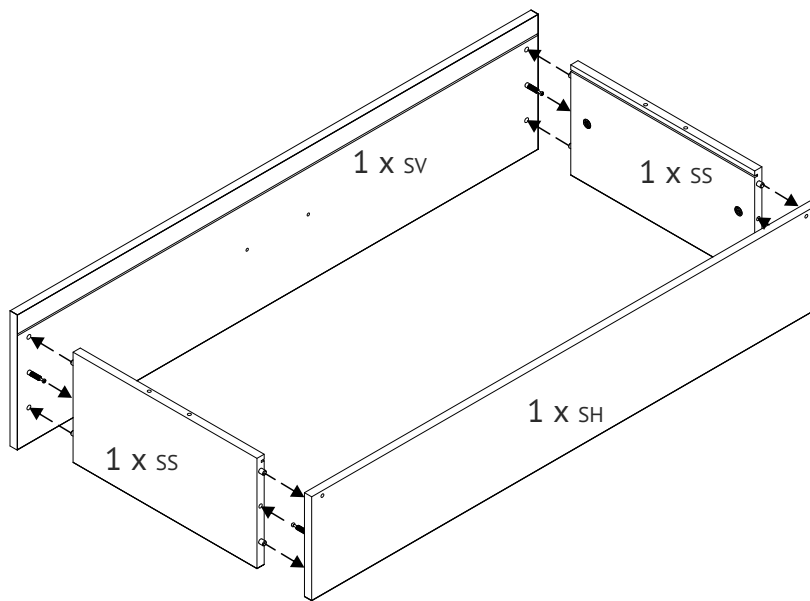

21 3x

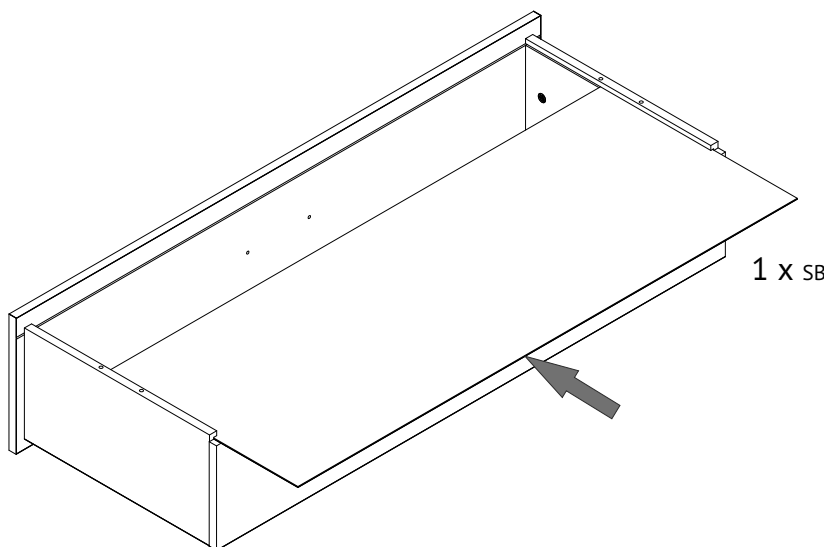

22

3x

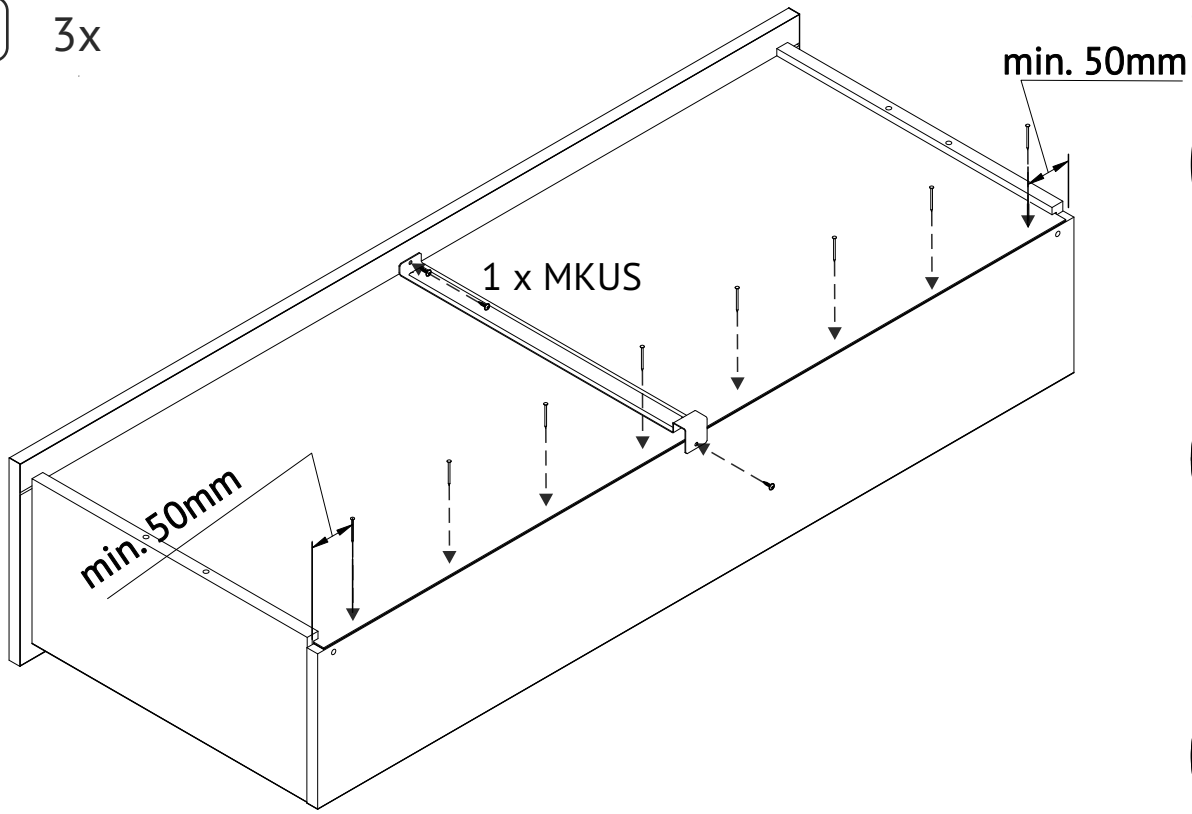

8 x NG 1,6/30

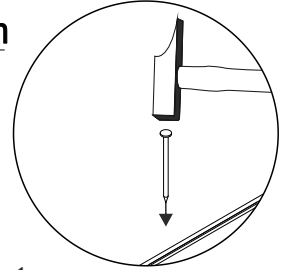

1 x VS 3/12

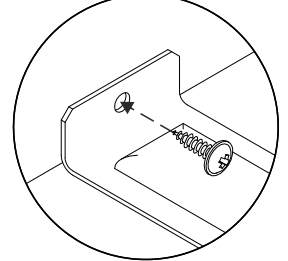

1 x VS 3/12

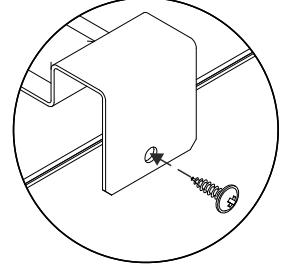

23

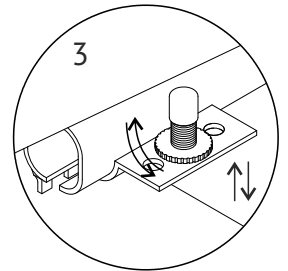
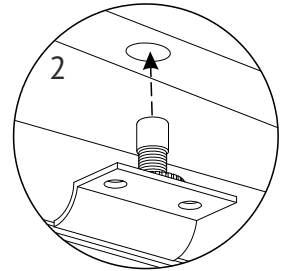
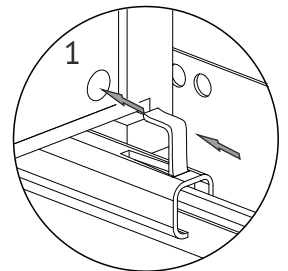
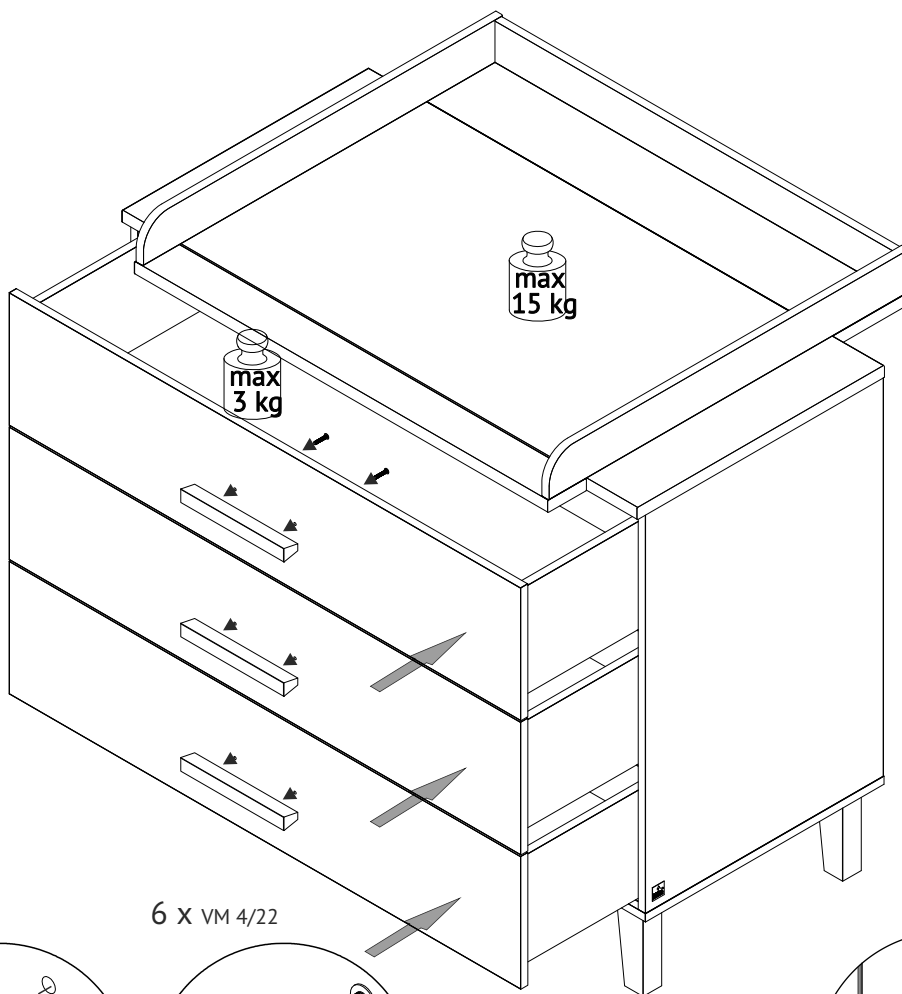

3 x HK

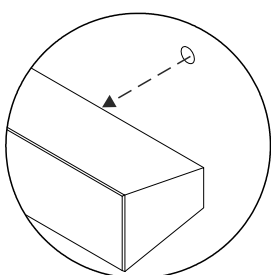

6 x VM 4/22

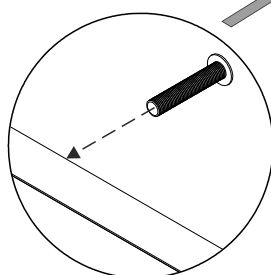

1 x ET

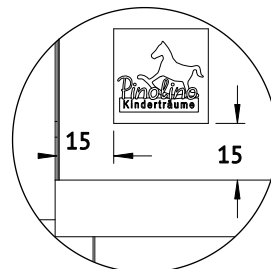
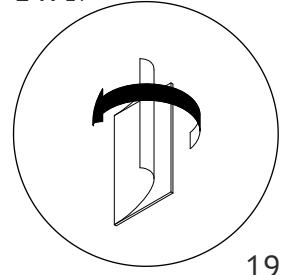

## ! Praktischer Umbau der Wickelkommode zu einer Wäschekommode

Practical conversion of the changing unit into a dresser

Transformation pratique de la commode à langer en commode classique

Transformación práctica de la cómoda a fajar en mueble con cajones

Trasformazione pratica del fasciatoio in cassetiera

Praktische omzetting van de babycommode in een latafel

- Die Wickelkommode darf nach Umbau nicht mehr zum Wickeln genutzt werden.
- After the conversion, the changing unit ought no longer to be used for changing the child.
- Après la transformation la commode doit être utiliser exclusivement comme une commode classique.
- Después la transformación, la cómoda de fajar será empleada exclusivamente como mueble con cajones.
- In seguito alla trasformazione, il fasciatoio sarà utilizzato esclusivamente come cassetiera.
- Na de omzetting dient de babycommode uitsluitend als latafel worden gebruikt.

A

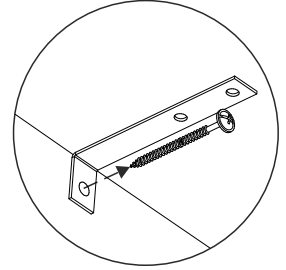
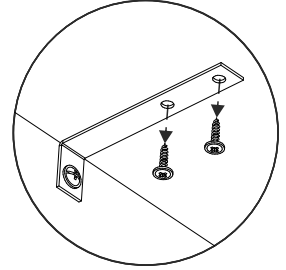
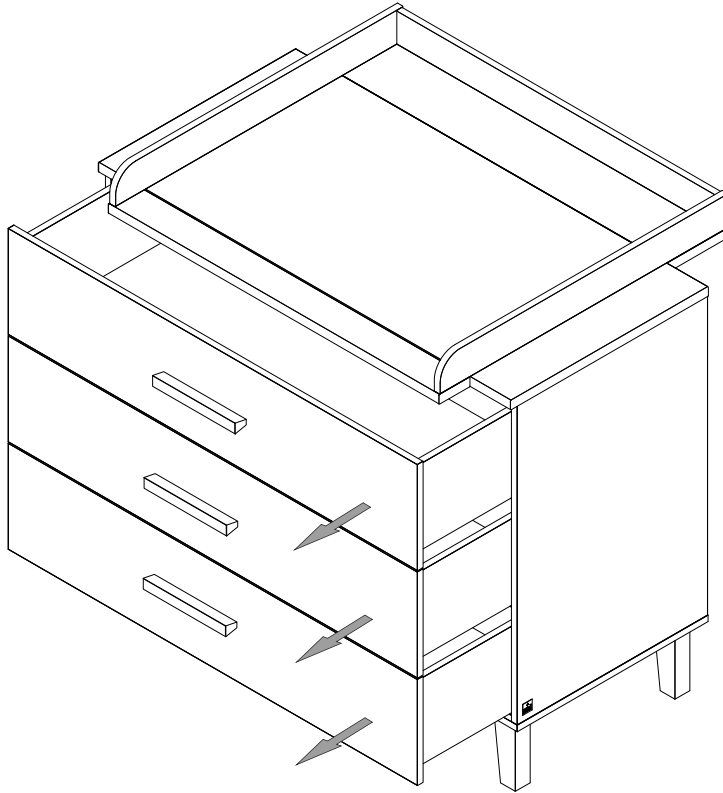

B

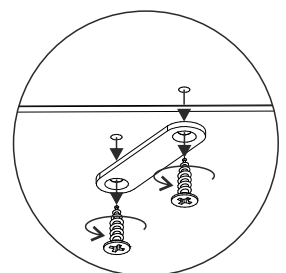
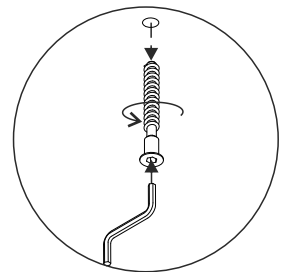
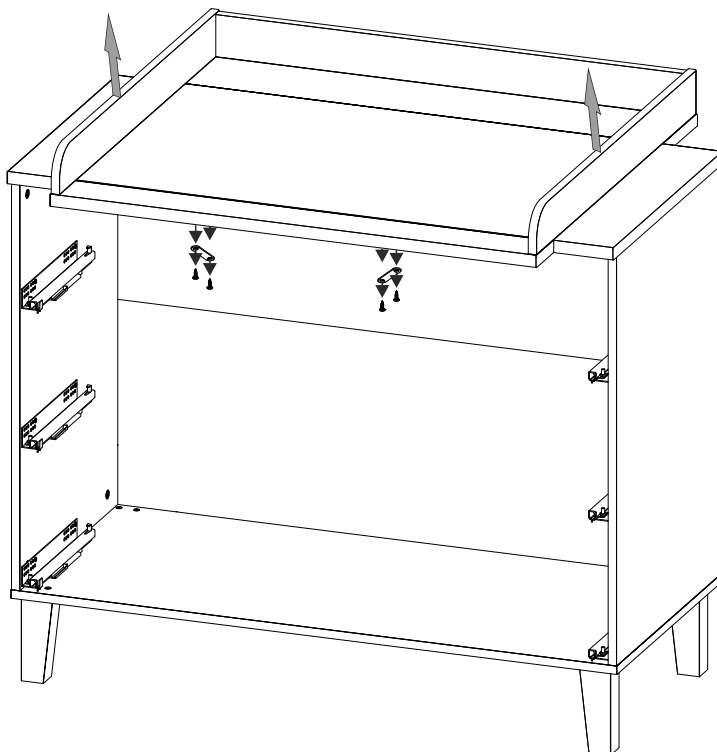

C

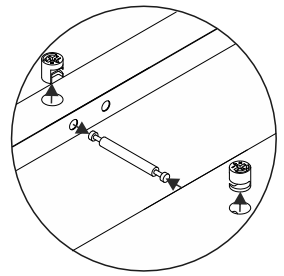
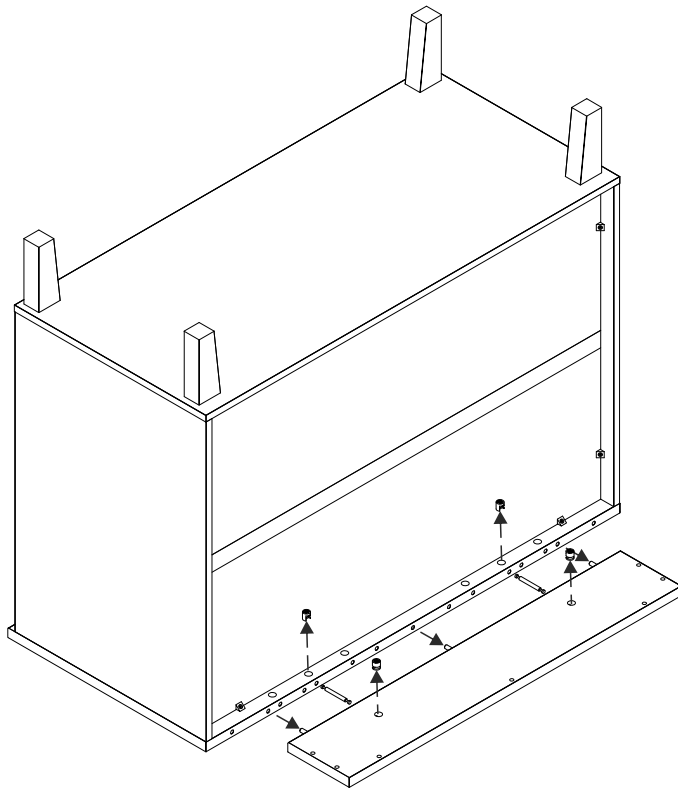

D

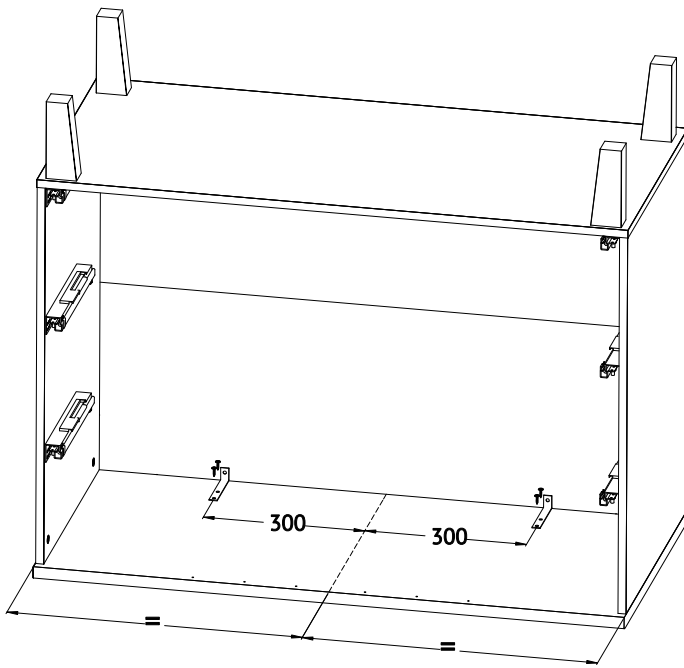

4 X VS 4/15  
2 X EML

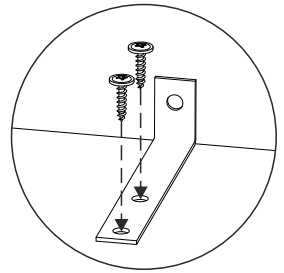

E

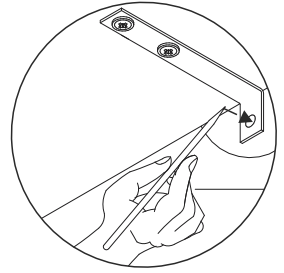
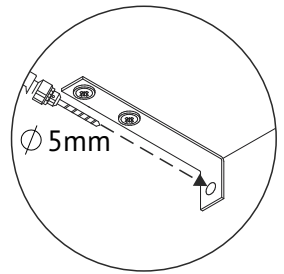
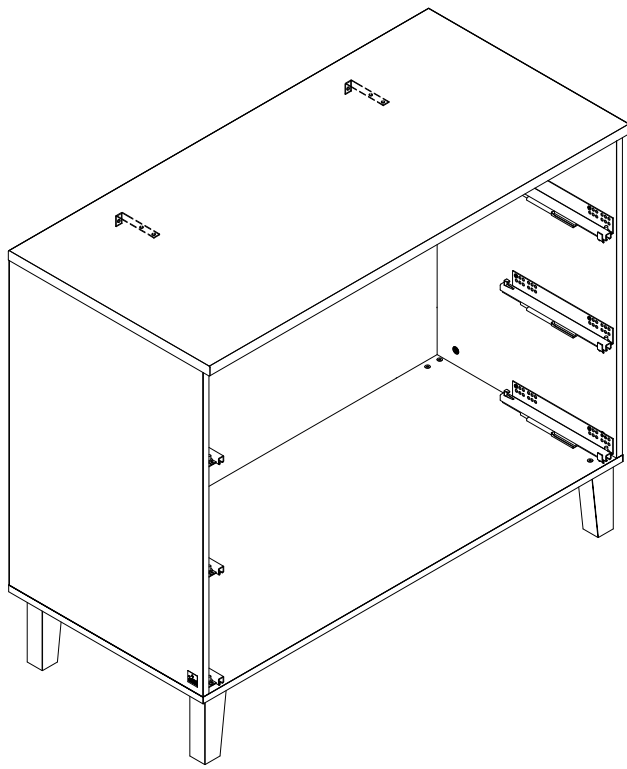

2 x WDK 10

2 x VS 5/100

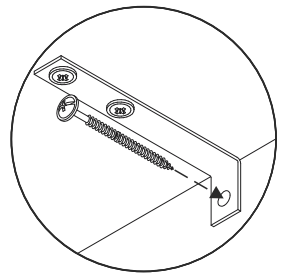
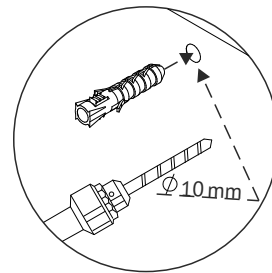

F

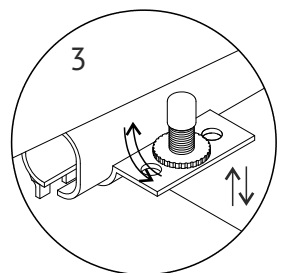
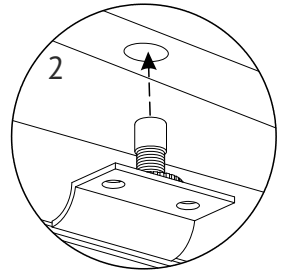
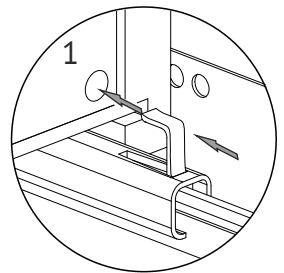
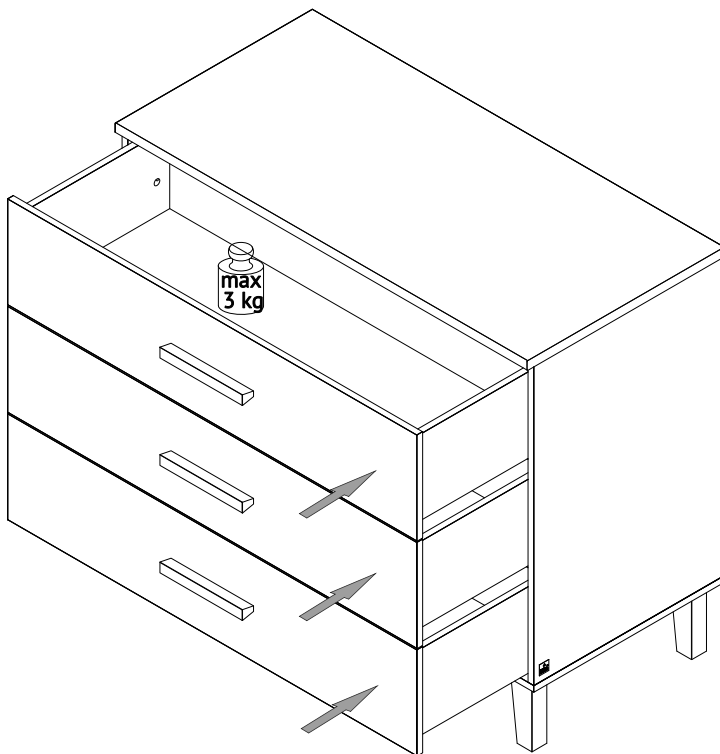

G



- Notizen:
- Notes:
- Notes:
- Apuntes:
- Nota:
- Notities: